



**UNIVERSITY OF NAIROBI**

**DEPARTMENT OF BIOCHEMISTRY**

**GENETIC DETECTION AND CHARACTERIZATION OF INFLUENZA  
VIRUSES IN SELECTED WILDLIFE AND HUMANS AT HIGH-RISK  
INTERFACE IN LAIKIPIA COUNTY.**

**BY**

**NGAMIE WINOLD MBINDYO (B.Sc.)**

**REG. NO. H56/88613/2016**

**A THESIS SUBMITTED IN FULFILLMENT OF THE REQUIREMENT FOR  
THE AWARD OF THE DEGREE OF MASTER OF SCIENCE IN  
BIOCHEMISTRY IN THE DEPARTMENT OF BIOCHEMISTRY IN THE  
UNIVERSITY OF NAIROBI.**

**2020**

## **Declaration**

This thesis is my original work and has not been presented for a degree or any other award in any other University.

Signature \_\_\_\_\_

Date \_\_\_\_\_

Winold Mbindyo Ngamie

This thesis has been submitted for examination with our approval as University supervisors:

Signature \_\_\_\_\_

Date \_\_\_\_\_

Dr. Joseph Kamau

Department of Biochemistry

University of Nairobi

Signature \_\_\_\_\_

Date \_\_\_\_\_

Dr. Lilian W. Waiboci

Department of Biochemistry

University of Nairobi

## **Dedication**

To the Almighty God, my parents Mr and Mrs Mbindyo Ngamie, my brothers Bervon and Derrick, my faithful wife Ruth Ngami, and my son Memphis Mbindyo. I affectionately dedicate this work to you for your persistent prayers. Your support has been a never-ending spring of hope, your belief in me is a constant source of strength.

## **Acknowledgments**

I wish to express my sincere gratitude to:

The staff and postgraduate students in the University of Nairobi, Department of Biochemistry and particularly my supervisors Dr. Kamau and Dr. Waiboci for their support, encouragement, advice and most of all patience.

The Institute of primate research, department of reproductive health, molecular biology staff for their unwavering support.

My friends for their advice, help, and assistance whenever needed.

## Table of contents

<b>Declaration</b> .....	<b>ii</b>
<b>Dedication</b> .....	<b>iii</b>
<b>Acknowledgments</b> .....	<b>iv</b>
<b>List of tables</b> .....	<b>viii</b>
<b>List of figures</b> .....	<b>ix</b>
<b>List of appendices</b> .....	<b>xi</b>
<b>List of abbreviations and Acronyms</b> .....	<b>xii</b>
<b>Abstract</b> .....	<b>i</b>
<b>CHAPTER ONE</b> .....	<b>1</b>
<b>INTRODUCTION</b> .....	<b>1</b>
<b>1.1 Influenza as an emerging infectious disease.</b> .....	<b>1</b>
<b>1.2 Problem statement</b> .....	<b>4</b>
<b>1.3 Project justification</b> .....	<b>4</b>
<b>1.4 Hypothesis</b> .....	<b>5</b>
1.4.1 Null Hypothesis.....	5
1.4.2 Alternative Hypothesis .....	5
<b>1.5 Objectives</b> .....	<b>5</b>
1.5.1 Overall objective. ....	5
1.5.2 Specific objectives.....	5
<b>CHAPTER TWO</b> .....	<b>6</b>
<b>LITERATURE REVIEW</b> .....	<b>6</b>
<b>2.1 Influenza virus Family</b> .....	<b>6</b>
<b>2.2 Structure of Influenza A virus.</b> .....	<b>6</b>
<b>2.3 Influenza A virus gene Segments</b> .....	<b>8</b>
2.3.1 Viral polymerase .....	8
2.3.2 Haemagglutinin .....	11

2.3.3 Matrix-1.....	12
2.3.4 Matrix-2.....	12
2.3.5 Neuraminidase.....	12
2.3.6 Non-structural protein (NS1) .....	13
<b>2.4 Virus replication cycle .....</b>	<b>13</b>
2.4.1 Virus Attachment .....	13
2.4.2 vRNAs Replication .....	14
<b>2.5 Epidemiology of influenza .....</b>	<b>15</b>
<b>CHAPTER THREE .....</b>	<b>16</b>
<b>MATERIALS AND METHODS .....</b>	<b>16</b>
<b>3.1 Ethics .....</b>	<b>16</b>
3.1.1 Human .....	16
3.1.2 Animal.....	16
<b>3.2 Study site and design.....</b>	<b>16</b>
<b>3.3 Sample collection .....</b>	<b>18</b>
3.3.1 Animals .....	18
3.3.2 Human .....	18
<b>3.4 Detection and characterization of influenza viruses. ....</b>	<b>21</b>
3.4.1 RNA extraction .....	21
3.4.2 cDNA synthesis.....	21
3.4.3 Polymerase Chain Reaction. ....	22
3.4.4 Agarose Gel electrophoresis and sequencing.....	23
<b>3.5 Characterization and determination of relatedness.....</b>	<b>24</b>
3.5.1 Sequence analysis.....	24
3.5.2 Sequence alignment and Phylogenetic analysis .....	24
<b>CHAPTER FOUR .....</b>	<b>25</b>
<b>4.0 RESULTS.....</b>	<b>25</b>
<b>4.1 Influenza virus PCR amplification. ....</b>	<b>25</b>
<b>4.2 Influenza virus characterization .....</b>	<b>29</b>

<b>4.2.1 Sequences Analysis</b> .....	29
4.2.2 Sequence similarity and identity .....	30
4.2.3 Multiple Sequence Alignment.....	31
4.2.4 Phylogenetic characterization .....	33
<b>CHAPTER FIVE</b> .....	<b>38</b>
<b>5.0 DISCUSSION, CONCLUSION AND RECOMMENDATION</b> .....	<b>38</b>
<b>REFERENCES</b> .....	<b>40</b>
<b>APPENDICES</b> .....	<b>48</b>

**List of tables**

**Table 1:** vRNA segments versus the encoded proteins of IAV.....8

**Table 2:** Results of oral swabs PCR tests.....26

**Table 3:** Results of rectal swabs PCR .....26

**Table 4:** Showing the nucleotide identity (%) and amino acid identity (%), above and below the diagonal receptively.....30



## List of figures

<b>Figure 1:</b> Factors that contribute to the transmission of emerging infectious diseases (EID) in humans, wildlife and domestic animals. DOI: 10.1126/science.287.5452.443.....	2
<b>Figure 2:</b> Main structural components of Influenza A virus obtained from virology blog about viruses and viral disease. ....	7
<b>Figure 3:</b> Schematic of IAV PB1 subunit showing the structural and functional domain. Abbreviations: RdRp, RNA-dependent RNA polymerase; PBS, promoter binding site; NLS, nuclear localization signal. ....	10
<b>Figure 4:</b> Influenza A Virus replication cycle (Das et al., 2010). ....	15
<b>Figure 5:</b> Sampling site in Laikipia County in Kenya, with the location of the Mpala Ranch and Conservancy doi.org/10.1186/2041-7136-2-10. ....	17
<b>Figure 6:</b> Showing sample collection from humans (a), bats (b) and non-human primates (c and cages for capturing non-human primates (d)). ....	20
<b>Figure 7:</b> Agarose gel analysis of 457 bp cytochrome oxidase 1 gene in non-human primate, human, rodent and bat samples for barcoding. ....	27
<b>Figure 8:</b> Agarose gel analysis image of the PB1 amplicons from September 2017 bat (Chaerephon spp) sample. ....	27
<b>Figure 9:</b> Gel photo of a 400bp PB1 gene (segment 2) segment of influenza virus from May 2018 baboon and human samples. ....	28
<b>Figure 10:</b> Illustration to show similarity by BLASTn of detected influenza virus with sequenced from the database. ....	29
<b>Figure 11:</b> PB1 nucleotide multiple sequences alignment (conservation plot) of Laikipia samples. ....	31

<b>Figure 12:</b> PB1 translated amino acid multiple sequences alignment showing the motif III (red bracket) and motif IV (blue bracket). .....	32
<b>Figure 13:</b> Phylogenetic tree of partial nucleotide sequences (PB1) of Laikipia samples. ....	33
<b>Figure 14:</b> Phylogenetic tree of translated amino acid PB1 sequences (ORF2) of Laikipia samples.....	34
<b>Figure 15:</b> Phylogenetic tree inferred from PB1 nucleotide sequences of Laikipia samples and related sequences from the database.....	35
<b>Figure 16:</b> Phylogenetic tree of translated PB1 amino acid sequences of Laikipia samples. ....	36

## List of appendices

<b>Appendix 1:</b> Primers used for PCR reaction.....	48
<b>Appendix 2:</b> Primers used for Barcoding or RNA quality check. ....	48
<b>Appendix 3:</b> Reagent preparation.....	48
<b>Appendix 4:</b> Cytochrome Oxidase 1 gene sequences of rodents and bats for DNA barcoding.....	49
<b>Appendix 5:</b> Kenyan human, baboons and bat partial PB1 nucleotide and amino acid sequences.....	50
<b>Appendix 6:</b> Human Subject Approval.....	53
<b>Appendix 7:</b> Animal use approval.....	54

## List of abbreviations and Acronyms

WHO	World Health Organization
PCR	Polymerase Chain Reaction
RNA	Ribonucleic Acid
DNA	Deoxyribonucleic Acid
IPR	Institute of Primate Research
KWS	Kenya Wildlife Service
BLASTn	Basic Local Alignment and Search Tool - nucleotide
BLASTp	Basic Local Alignment and Search Tool - protein
PB1	Polymerase basic protein 1
cDNA	Complementary deoxyribonucleic acid
PA	Polymerase acidic protein
IV	Influenza virus
RBP	RNA binding protein
HA	Hemagglutinin
NA	Neuraminidase
IAV	Influenza A virus
NEP	Nuclear Export Protein
MSA	Multiple Sequence Alignment
ER	Endoplasmic Reticulum
PKR	Protein Kinase R
Mgtp	Methyl Guanosine Triphosphate
PB2	Polymerase Basic 2 protein

## **Abstract**

Incidences of emerging and re-emerging zoonotic infectious diseases increase especially at the livestock-wildlife-human overlap, an interface commonly found in Kenya. Such overlaps intensify during the dry season and prolonged drought. This is especially true for Laikipia County, populated by dense wildlife and many pastoralists; hence detection, and characterization of influenza viruses in bats, rodents, Olive baboons, and human sample was carried out at this high-risk interface. 1497 oral and rectal swab samples in TRIzol were collected during the wet and dry season which coincide with the month of May and September respectively. This was done from 2017 to 2018 in olive baboons (*Papio anubis*), bats (*Chaerephon spp*), rodents (*Mus musculus*) and humans. Oral and rectal/fecal samples in TRIzol were analyzed using gene specific primers directed to conserved regions of polymerase protein 1 gene of influenza viruses; sequencing and sequence analysis was done on PCR positive samples. Nine samples were positive for influenza virus but only seven samples (approx. 0.6%) were sequenced successfully (one oral swab from human, five orals swabs from baboons and one rectal sample from bat). Nucleotide and aminoacid sequence similarity searches (through BLASTn, BLASTp) of the diagnostic 400-bp PB1 amplicons derived from bat, Olive baboons and human samples were very similar to each other and were closely related to influenza type A sequences as the most significant matches (>95%). Phylogenetic analyses of these viruses revealed a close relation between non-human primates and human influenza virus sequences (76 -78% nucleotide and amino acid sequence similarity). Bat influenza virus sequence (KEAB0224) was genetically distinct and appeared as an outgroup in all phylogenetic trees suggesting the Bat virus was more ancient compared to the human. Distinct clustering of the detected Bat influenza virus when compared to viral sequences available in the database could be due to this being the first-time influenza virus is being detected in bat and non-human primates in Laikipia County. Hence further work on influenza virus diversity in Kenya, as well as on the ecology and behavior of susceptible species, is needed to understand the origins and evolution.

# CHAPTER ONE

## INTRODUCTION

### 1.1 Influenza as an emerging infectious disease.

Influenza is a viral infectious disease caused by viruses from Orthomyxoviridae family referred to as influenza viruses. Influenza infects the upper respiratory of pigs, humans, horses, birds, and sea mammals, and its host reservoir is the wild waterfowl, particularly ducks (Mettenleiter and Sobrino, 2008).

The symptoms of influenza infection in humans include nasal congestion, sore throat, cough, and fever. The old, the young, and individuals with underlying medical problems e.g., diabetes are most susceptible to severe illness resulting from influenza infection (Lee, *et al.*, 2019). Outbreaks arise during winter, in temperate regions but influenza spreads year-round in regions near the equator (Sooryanarain and Elankumaran, 2015).

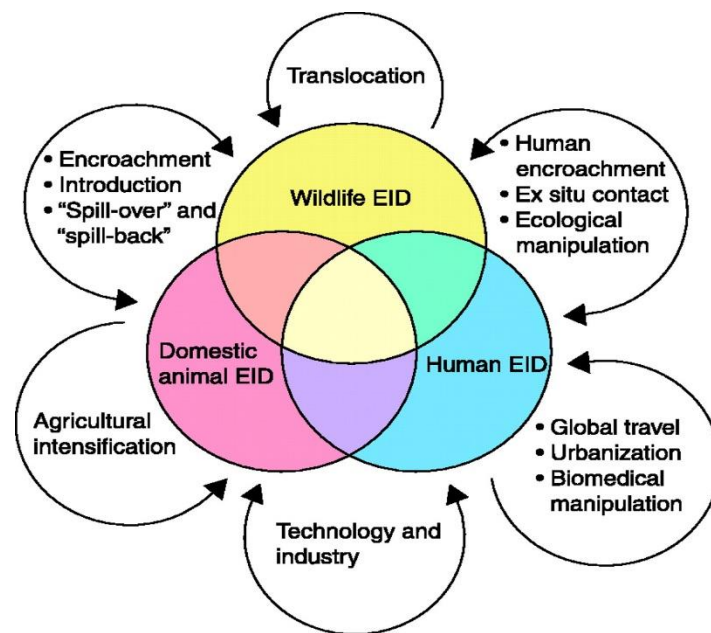
Larger outbreaks known as pandemics occur intermittently with four pandemics already experience; 2009 H1N1 influenza pandemic, 1968 Hong Kong influenza, 1957 Asian influenza and 1918 Spanish influenza (Monto and Fukuda, 2019). These pandemics arise from a novel fully transmissible influenza A virus from one species; usually a susceptible animal and spills over to humans (Morens and Fauci, 2013). These emphasizes the unpredictable nature of novel influenza A viruses and the social-economic burden associated with its outbreaks (William *et al.*, 2014).

Co-distribution of several lineages of IAVs in wildlife and human population has led to genetic reassortment after co-infection of a mixing host with two subtypes of influenza A virus resulting into a novel virus with high genomic diversity (Ma *et al.*, 2009) (Tao *et al.*, 2015); E.g, segments of avian, swine and human influenza A virus constituted the 2009 H1N1 pandemic influenza A virus. Furthermore, recombination by independent assortment of swine and human IAV due to their segmented genome, has led to evolution, virulence and host tropism of these viruses (He *et al.*, 2008).

Wildlife has played a key role as reservoir host of 71% of zoonotic pathogens that infect livestock and/or humans (Kruse *et al.*, 2004). Hence surveillance of emerging infectious disease at their source in wildlife is an important public health emergency preparedness

(Cleaveland *et al.*, 2001) (Wolfe *et al.*, 2007). This one health surveillance is warranted especially in areas with high wildlife biodiversity and critical points (high risk interface) where interaction among populations of humans, livestock and wildlife favors cross-species transmission and spread of viral pathogen (Allen *et al.*, 2017).

These critical points are characterized by risk factors that drive disease emergence which include cultural practises, deforestation, human population expansion (Jones *et al.*, 2008) (Kruse *et al.*, 2004) and climate change, which lead to habitat alteration, species evolution (Karesh *et al.*, 2012). These interactions are illustrated in Figure 1



**Figure 1:** Factors that contribute to the transmission of emerging infectious diseases (EID) in humans, wildlife and domestic animals. DOI: 10.1126/science.287.5452.443

In Kenya such an interface with increased wildlife-human-livestock interaction exist in Laikipia. This interface is characterized by nomadic livelihood and movement of wildlife to human settlements areas in search of food and water which may promote close interaction among species that would otherwise not be in close contact providing an opportunity for spill-over or spill back of infectious agents including influenza viruses.

There being scanty information about influenza viruses circulating in wildlife in Kenya, no recorded cases of influenza transmission in humans prior to this project, and reports of patients with flu-like illness (ILI) in local public health facilities there is a need to determine presence of influenza virus Laikipia County. This study, therefore sought to detect, and characterize influenza viruses in bats, non-human primates, rodents and human samples collected at high risk interface area in Laikipia County using influenza RNA polymerase gene (PB1) as a target for detection. The PB1 gene was selected because it is highly conserved in strains of RNA viruses.



## **1.2 Problem statement**

Recurring influenza A virus outbreaks have been associated with high mortality due to diversity of susceptible animals reservoirs, multiple viral genes, antigenic shifts or antigenic drifts that allow evasion from preexisting immunity (Malanoski and Lin 2013). Regarding impending outbreaks, keeping an eye on animal influenza viruses that recurrently infect humans is important and particularly carry out surveillance of influenza virus in wildlife which have been linked to two-thirds of emerging infectious disease.

Massive encroachment by humans into wildlife reserved areas (Kivai, 2010) and cultural behaviours such as handling and eating dead animals has made Laikipia a high-risk interface for influenza disease emergence. Hence in this study early molecular identification and characterization of influenza viruses circulating in bats, rodents, Olive baboons and humans was carried out as a level of preparedness to identify any looming public health emergency in Laikipia county.

## **1.3 Project justification**

Areas around the globe with high biodiversity of livestock, wildlife, and humans have a great potential for infectious disease spill over (Brian *et al.*, 2018). Geographical areas with conducive agricultural production systems have increased potential of influenza virus reassortment (Fuller *et al.*, 2013), particularly areas with increased wildlife and livestock density in a complex interaction with human population. In Laikipia county animal-human interaction, cultural practices (consumption of sick or dead domestic or wildlife), bush meat hunting and water point sharing with wildlife are pre-disposing risk factors for emergence of influenza disease and livestock overlap (Jones *et al.*, 2008). Thus, finding potential outbreak sites in Laikipia county through molecular surveillance aimed at detecting influenza viruses at their source is an important public health concern (Cunningham *et al.*, 2017).

## **1.4 Hypothesis**

### **1.4.1 Null Hypothesis**

There are no influenza viruses circulating in selected wildlife and humans at the high-risk interface in Laikipia County.

### **1.4.2 Alternative Hypothesis**

There are influenza viruses circulating in selected wildlife and humans at the high-risk interface in Laikipia County.

## **1.5 Objectives**

### **1.5.1 Overall objective.**

To genetically characterize influenza virus in bats, rodents, non-human primates (Olive baboons) and humans in Laikipia County.

### **1.5.2 Specific objectives.**

- i. To determine the presence of influenza virus infecting humans, bats, rodents, and olive baboons in Laikipia County.
- ii. To establish the genetic diversity of detected influenza virus infecting humans and wildlife species above in relation to isolates from other regions of the world.

## CHAPTER TWO

### LITERATURE REVIEW

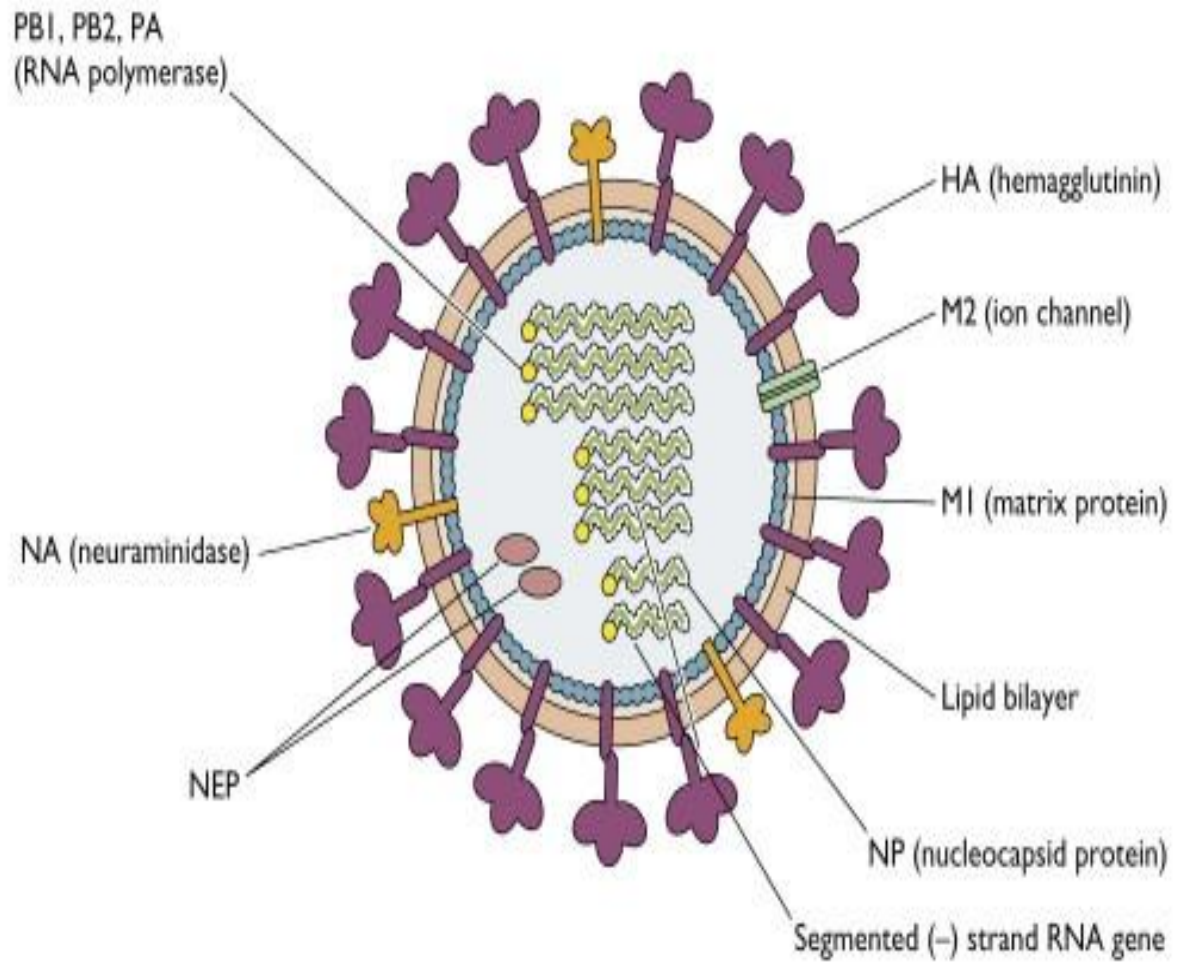
#### 2.1 Influenza virus Family.

Influenza viruses are RNA viruses that belong to the Orthomyxoviridae family. This family contains six viral genera; Influenza A to D viruses, Isavirus and Thogotovirus (Wright *et al.*, 2013). The first three genera comprise viruses to which vertebrates are susceptible including humans, birds, and other mammals.

#### 2.2 Structure of Influenza A virus .

IAV virions are enveloped, generally occurring in both spherical form of around 80nm-120nm diameter and filamentous form of around 20 nm diameter and 200 nm -300 nm long upon cultivation in laboratory. It consists of 8 single stranded RNA gene segments (Figure 2) encapsulated by nucleoprotein surrounded by surface glycoproteins spiking (approximately 16nm in length) from the lipid envelope. These surface glycoproteins have distinct functions and include HA and NA molecules (Suzuki *et al.*, 2005). Table 1 is a summary of the gene segments and the protein that each encodes.

Hemagglutinin spikes appear rod shape and protrude from the envelope as a trimer making up approximately 80% of the projections (Wilson *et al.*, 1981). The mushroom shaped tetramer NA spikes constitute about 10%–20% of the overall glycoproteins on the virion surface (Colman *et al.*, 1989). The genome segments length ranges from 736 to 2396 nucleotides and comprising of viral RNA of around 10Kb to 13.6Kb in size with conserved and partially complementary 5'- and 3'- end sequences enclosed within a capsid composed of helically arranged nucleoprotein (Carstens, 2012).



**Figure 2:** Main structural components of Influenza A virus obtained from virology blog about viruses and viral disease.

## 2.3 Influenza A virus gene Segments

The arrangement of segments 1 to 6 within Influenza A virus genome is monocistronic while the intertwined segment 7 and 8 synthesize mRNAs that code for two proteins; Matrix proteins and Non-structural proteins (Lamb and Krug, 2001).

**Table 1:** vRNA segments versus the encoded proteins of IAV.

RNA segment	Gene product
1	PB2
2	PB1
3	PA
4	HA
5	Nucleoprotein
6	NA
7	M1 M2 Ion channel
8	NS - NS1(RBP) - NS2 (NEP)

### 2.3.1 Viral polymerase

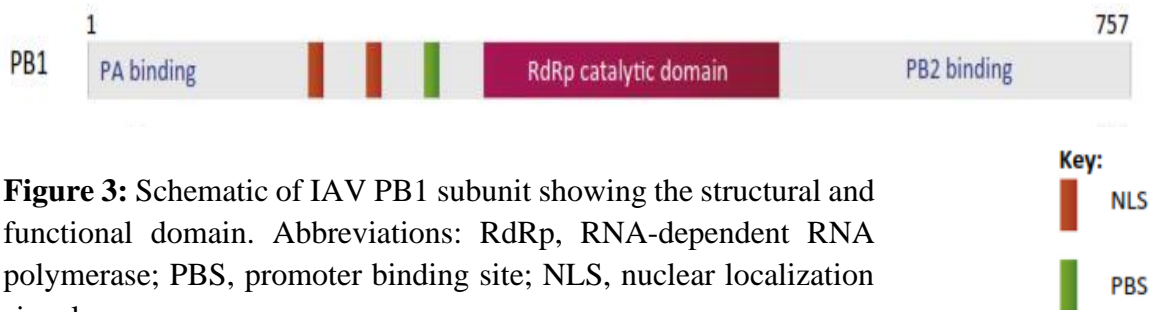
The heterotrimeric viral RNA polymerase of about ~250 kDa by mass contains 3 subunits; 2 polymerase basic subunits (PB1 and PB2) plus an acidic polymerase subunit (PA) encoded by segments two, one and three respectively. It catalyzes replication and transcription. Replication, binding of viral RNA, endonuclease activity, and cap-binding is carried out by the polymerase Acidic (PA) subunit (Maier *et al.*, 2008).

Polymerase Basic protein1 (PB1) is the main catalytic subunit, comprising of four highly conserved cooperatively functioning motifs of amino acid sequence (Motif I <sup>303</sup>TGDN<sup>306</sup>, Motif III <sup>438</sup>WDGLQSSDDFALI<sup>450</sup>, Motif II <sup>403</sup>LSPGMMMGMF<sup>412</sup>, Motif IV <sup>474</sup>GINMSKKKSYI<sup>484</sup>). The four motifs are extremely conserved among PB1 of all influenza A to C viruses and observed alterations are very unusual and conservative in nature. These sequences were identified through comparison of most viral RNA dependent DNA polymerase sequences, together with other RNA dependent RNA polymerase (Chu *et al.*, 2012).

Mini replicon studies on the essential role of conserved motifs on PB1 demonstrated at least one invariant amino acid per motif and further established the critical function of non-consensus amino acids flanking the conserved motifs towards the polymerase activity where any alterations abolish significantly its catalytic activity. Although the rare occurring Influenza viruses with mutated PB1 in their conserved motifs carry out replication and transcription, this activity is thought to arise from localized complementary mutations within the PB1 protein and/or in other viral polymerase components acquired by the respective viruses (Chu *et al.*, 2012).

Motif I and II reveal lower variability while motif III and IV displays high variability in influenza viruses of avian, human, swine and other origins. Lysine to arginine substitution at position 480, a conservative amino acid alteration frequently observed in motif IV increases the transcription and replication activity compared to the wildtype polymerase activity, is thought to have originated from swine influenza where it occurs more often than in humans and avian virus PB1 proteins (Chu *et al.*, 2012). Structural analysis and sequence comparison of DNA and RNA dependent viruses indicate motif III as an important functional domain and its involvement in the replicase and transcriptase activity due to the occurrence of Serine-Aspartic-Aspartic acid (SDD) consensus amino acid sequence for influenza viruses versus Glycine-Aspartic-Aspartic acid (GDD) in most other viral polymerase (Biswas & Nayak, 1994).

Polymerase basic protein 1 also contains independent binding site for assembly of polymerase acidic protein and polymerase basic protein 2 into a multifunctional polymerase complex as illustrated in Figure 3 (Dan *et al.*, 2018). Studies have indicated that mutations at this site inhibit RNA synthesis, hence a potential drug target for compounds capable of delinking the PB1–PB2 complex (Das *et al.*, 2010).



**Figure 3:** Schematic of IAV PB1 subunit showing the structural and functional domain. Abbreviations: RdRp, RNA-dependent RNA polymerase; PBS, promoter binding site; NLS, nuclear localization signal.

Polymorease Basic protein 2 a major determinant of viral infectivity is responsible for generating 5'-capped RNA fragments from the 5' end of the host cellular pre-messenger RNA molecules for cleavage by PA to primers for viral transcription (Graef *et al.*, 2010). Influenza virus RNA polymerase Immunoprecipitation studies has shown that it holds sites for PA and PB2 binding (Digard *et al.*, 1989) where the carboxyl- and amino-termini of PB1 are associated with PB2 and PA polymerase subunits, respectively (Gonzalez *et al.*, 1996). Interestingly, the PB2 protein is a determinant of virulence and host range of influenza viruses (Pflug *et al.*, 2014), also it regulates the innate immune system by inhibiting mitochondrial antiviral signaling protein MAVS.

Polymerase acidic protein is involved in viral assembly, proteolysis of host and viral proteins, and nuclear localization of the polymerase (Yuan *et al.*, 2009). PA endonuclease activity is carried out by the amino-terminal 209 residues PB2 (Dias *et al.*, 2009).

### 2.3.2 Haemagglutinin

Haemagglutinin (HA) is a trimeric influenza membrane glycoprotein and an abundant surface antigen of influenza A viruses (size 13.5nm, molecular weight 76kDA) involved in membrane fusion and receptor binding hence infectivity in naive host cells (Das *et al.*, 2010).

HA determines the serotype of influenza virus (i.e. viruses with the same type and number of surface antigens). Influenza A virus hemagglutinin (HA) is diverse with at least 18 different serotypes; It is divided into 2 groups, where group 1 contains twelve HA serotypes and group 2 six HA serotypes (Sutton *et al.*, 2017). Moreover, in combination with neuraminidase they are involved in viral subtype determination. Where 11 different neuraminidase subtypes (N1 through N11) and 18 hemagglutinin can possibly combine to give rise to 198 diverse influenza A viral subtypes combinations. Of this detection of 131 subtypes has been done in nature. Subtypes H17N10 and H18N11, are the most recent entries they were identified in Central (Tong *et al.*, 2012) and South American bats (Campos *et al.*, 2019). In Kenya the following subtypes have been reported H3N2, H1N1, H5N1 and H1N5 (Matheka *et al.*, 2013).

During virus replication HA exist in HA1 and HA2 conformation following serine protease cleavage. HA1 portion recognizes and binds terminal sialic acid residues and is exploited as an antigenic target against antibodies that neutralize influenza infectivity. HA2 mediates fusion of the cell membrane and the virus envelope (Cotter *et al.*, 2014). The close association between HA1 head region and the triple-stranded coiled-coil of  $\alpha$ -helices is broken during fusion due to the acidic pH of the endosome leading to dissociation of all 3 HA1 heads from HA2 (Stevens *et al.*, 2006). The extended helical structure exposes the fusion peptide after a conformational change in the loops linking fusion peptides to the coiled stem at the amino-terminal end of HA2, causing viral endocytosis (Skehel *et al.*, 2000). Only two human monoclonal antibodies neutralize various influenza A subtypes following antigenic changes in the head of HA1 (Sui *et al.*, 2009). The conserved epitope of HA near the base acts as an antibody binding site (Das *et al.*, 2010).



### **2.3.3 Matrix-1**

Matrix protein 1 is membrane-associated scaffold in the inner shell of the virion that interacts with both lipid bilayer and viral RNP via the Carboxy- and the NM domain respectively. During initiation of infection a conformational change in M1 protein is triggered by the influx of hydrogen ions and subsequent alienation of vRNPs-M1 linkage leading to the loss of viral particle rigidity and hence release of the viral contents to the host cell (Stauffer *et al.*, 2014).

### **2.3.4 Matrix-2**

This is a tetrameric ion channel protein consisting of four identical M2 helical monomers of 97 amino acids residue. It's the target of antivirals amantadine and remantadine (Stouffer, 2008; Zaitseva *et al.*, 2002). During cell fusion it maintains pH across the viral envelope. Endosomal acidification through receptor-mediated endocytosis during host cell invasion leads to activation of M2 channel which delivers protons entry into the virus core weakening the electrostatic interaction and hence dissociation of M1-RNP complexes. Matrix 2 proton selection and pH modulation property are due to conserved histidine 37 and tryptophan 41 residues within the proton channel where by histidine at position 37 is protonated with hydrogen atoms and therefore makes the pH low this phenomenon enhances the proton flow and so the release of the vRNPs (Lamb and Krug, 2001).

### **2.3.5 Neuraminidase**

The neuraminidase (NA) is a tetrameric mushroom shaped glycoprotein on the surface influenza A virion. For influenza A, eleven types of NA are known (Colman P. M., 1989). Antibodies targeting NA provide immunity against influenza virus infection by preventing virus release from infected cells (WHO, 2015). Neuraminidase is a target of different drugs like oseltamivir and zanamivir (Wang *et al.*, 2009). After infection, newly formed viral particles bud off following the exosialidase activity of NA to prevent aggregation of viral particles. Moreover, This sialidase activity aids in virus transportation to the target cell within the respiratory tract (Matrosovich *et al.*, 2004).

### **2.3.6 Non-structural protein (NS1)**

This is a homodimeric comprising of two domains: an effector domain and dsRNA binding domain joined by a linker. It's important in viral replication and disrupting antiviral response through inhibiting induction of IFNs- $\alpha/\beta$ . NS1 ensures replication of IAV in infected host by interacting with cellular proteins, such as 2'-5'-oligoadenylate synthetase, PKR, and cleavage polyadenylation specificity factor 30, that counters their immune responses (Das *et al.*, 2010).

## **2.4 Virus replication cycle**

### **2.4.1 Virus Attachment**

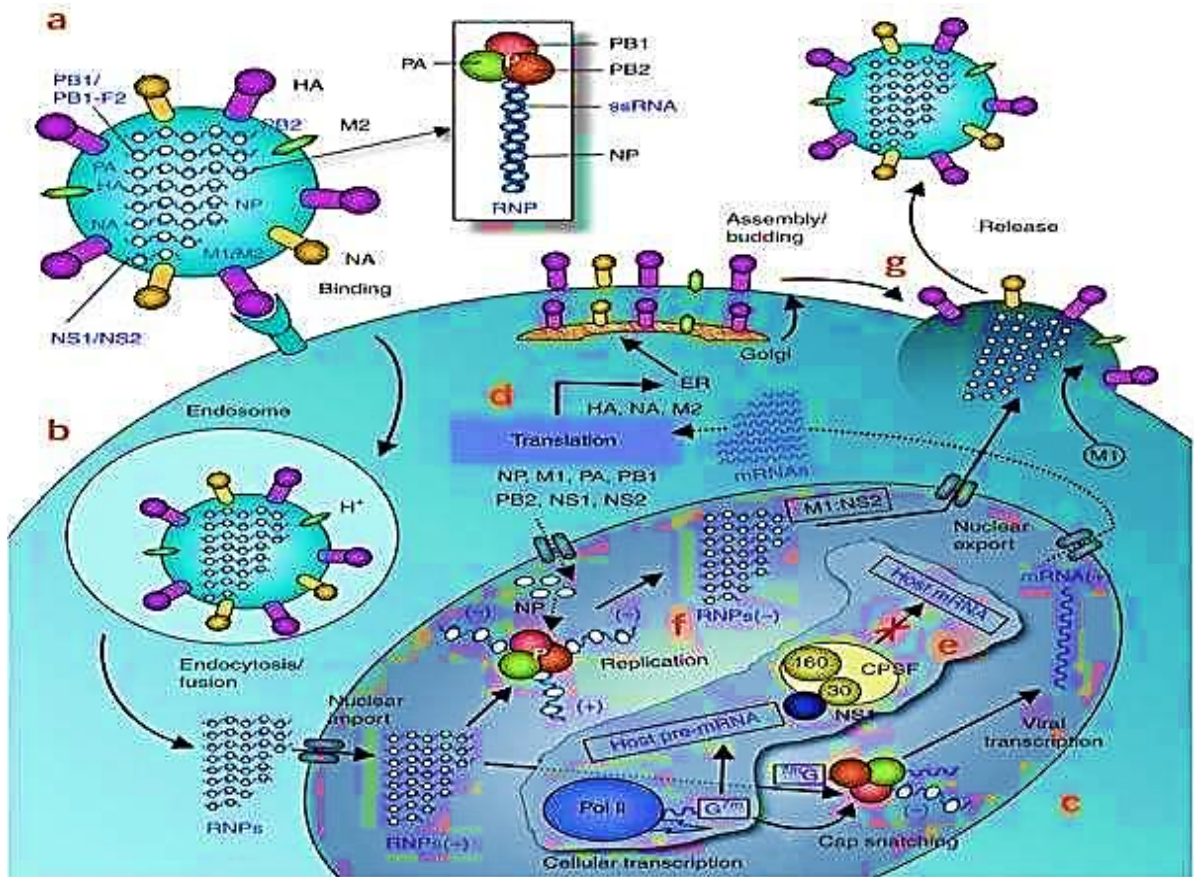
Influenza virus infects tracheal epithelial cells in the lower and upper respiratory tracts by binding to N-acetylneuraminic (sialic) acid as the primary targets (figure 4). The terminal sialic acid exists in different unique steric configuration due to the carbon-2 which can bind carbon 3 or 6 of galactose forming  $\alpha 2,3$  or  $\alpha 2,6$  glycosidic linkages which are the central entry point for influenza A viruses (Watanabe *et al.*, 2010). Both humans and non-human primates have similar receptors (Margine *et al.*, 2014). On the cell surface viral HA recognizes and binds preferentially and specifically to sialic acid residues with  $\alpha 2, 6$  or  $\alpha 2, 3$  linkages in human and avian, respectively (Margine *et al.*, 2014) while in swine both linkages;  $\alpha 2, 6$  and  $\alpha 2, 3$  are present therefore swine may be infected by influenza viruses that infect humans and those that infect avians at the same time. Thus, swine may act as 'mixing vessels' after co-infection with human, swine and/or avian influenza viruses (Margine *et al.*, 2014). Following attachment of HA molecules to the host cell sialic acid residues, endocytosis occurs (figure 4. b) where the acidic endosomal compartment prompts a large structural change in the hemagglutinin exposing the fusion peptide hence merging of the viral and endosomal membranes. Moreover, inflow of protons through the Matrix 2 ion channel into the virus leads to acidification of viral particle hence disassociation of packaged vRNPs from M1 (Das *et al.*, 2010). The nuclear localization sequences within the numerous nucleoproteins then targets these vRNPs to the nuclear pore by recruiting adapter protein importin-alpha (Wu and Pante, 2009).

### 2.4.2 vRNAs Replication

Viral mRNA replication inside the nucleus by viral polymerase starts with the binding of PB2 to the capped nascent host pre-mRNA (Schrenzel *et al.*, 2011) which is cleaved downstream in the region 10–13nts by the PA's endonuclease domain (Schweiger *et al.*, 2006). It is then positioned into the catalytic site of PB1 for elongation using the vRNA as a template (Thierry *et al.*, 2014), 'reiterative shuttering' then leads to polyadenylation of the transcript (Fodor, 2013).

The transcribed mRNAs are exported to the cytosol for translation into viral proteins in the ribosomes (for segment 1, 2, 3, 5, 7(M1), and 8) and ER membrane-associated ribosomes (for segment 7(M2), 4 and 6). Membrane proteins are then glycosylated in the golgi apparatus of the host cell and exported to the cell membrane (Castro *et al.*, 2017).

M1 protein links NS2 to vRNPs hence mediates transport of vRNPs to cytoplasm; through associated interaction with CRM1 protein (Huang *et al.*, 2013) after which they are trafficked to the cell membrane for incorporation into new virions (Nayak *et al.*, 2004). Following budding, the terminal sialic acid in the hemagglutinin and Neuraminidase proteins molecules of the new viruses cause aggregation and adsorption of the virus to the cell surface (Rossman and Lamb, 2011) hence, the hydrolytic activity of the NA of virus progeny removes these SA residues to release the virus.



**Figure 4:** Influenza A Virus replication cycle (Das *et al.*, 2010).

## 2.5 Epidemiology of influenza

Surveillance studies indicate that influenza activity in temperate areas of the northern hemisphere and southern hemisphere peaks during winter months between November to March and April to September, respectively (Cox and Ziegler, 2003). Influenza A virus circulates in Kenya year-round with peaks during the wet seasons (Muthoka, 2013 and Waiboci *et al.*, 2016). Infections manifest both as mild upper respiratory tract infection (flu-like illness) and as severe acute respiratory illness (SARI) requiring hospitalization (Emukule *et al.*, 2015).

Seasonal influenza epidemics have also been reported in Kenya with the recent one being the 2016 influenza A and B outbreak in Nakuru County which caused the death of 275 children of 0-5 years (“Influenza outbreak Nakuru,” 2016). Such epidemics occur in discrete pattern depending on the climate coupled with the continuous alteration in the antigenic properties of influenza virus and more specifically influenza A and B viruses (Katz *et al.*, 2013).

## **CHAPTER THREE**

### **MATERIALS AND METHODS**

#### **3.1 Ethics**

##### **3.1.1 Human**

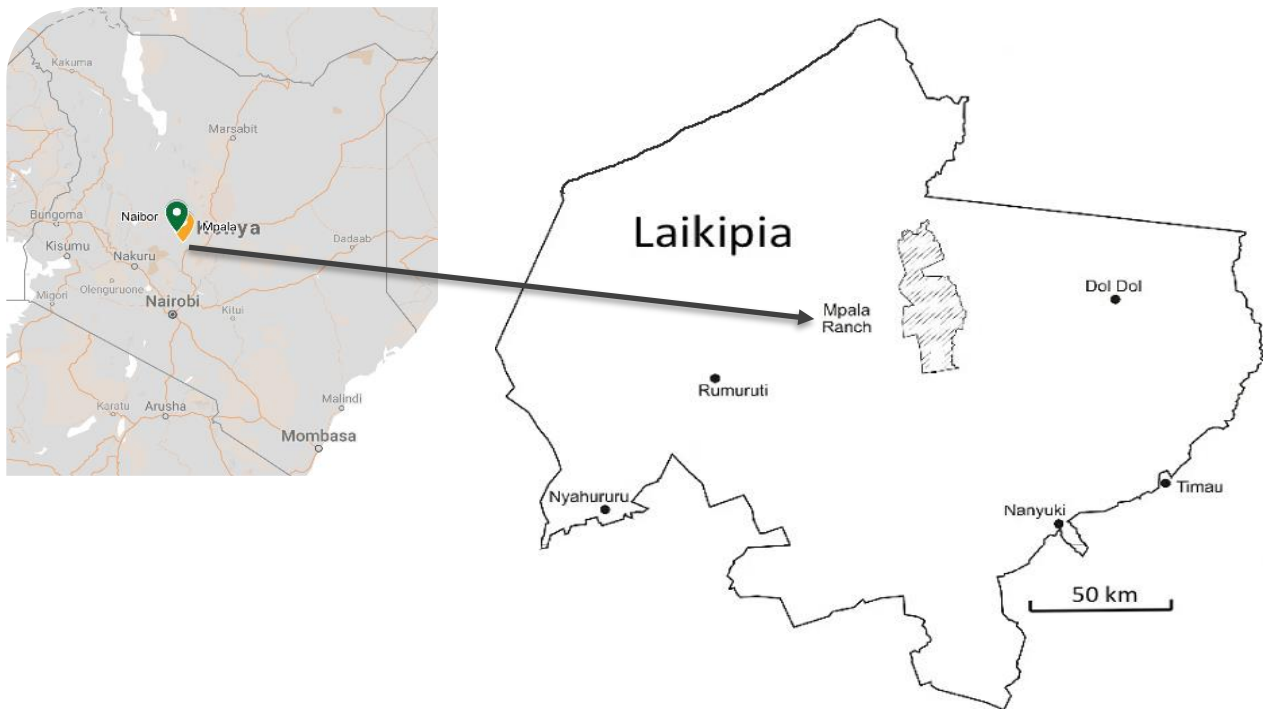
Ethical clearance for the collection of human samples and human subject approval were given by the Kenya Medical Research Institute (KEMRI) with reference number (KEMRI/RES/7/3/1) (Appendix 6). Human participants filled informed consent forms prior to their recruitment to the study and sample collection.

##### **3.1.2 Animal**

The Kenya Institute of Primate research ethics committee issued the procedure for animal care, capture, and use; ref number IERC/08/16 (Appendix 7).

#### **3.2 Study site and design**

The location of the study site was the Mpala Research Centre; latitude ( $0^{\circ} 22' 25.68''$  N and  $36^{\circ} 54' 18.72''$  E) and surrounding lands (Naibor);  $0^{\circ} 9' 50.4''$  N and longitude  $37^{\circ} 1' 22.44''$  E (Figure 5). The study site is situated in Laikipia County which has high level of interaction between livestock, wildlife and humans due to the presence of wildlife conservancies, human settlement areas and livestock production systems. Such biodiversity is expected to increase risk of pathogen spillover from reservoirs in wildlife into livestock or human populations. Convenient sampling was applied in the sample collection for detection and characterization of influenza viruses.



**Figure 5:** Sampling site in Laikipia County in Kenya, with the location of the Mpala Ranch and Conservancy [doi.org/10.1186/2041-7136-2-10](https://doi.org/10.1186/2041-7136-2-10).

### **3.3 Sample collection**

Sample collection was done during the wet and dry season which coincide with the month of May and September respectively. This was done in 2017 and 2018.

#### **3.3.1 Animals**

Bats were captured using mist nets, placed in a porous cotton (with a draw-string mouth), weighed and identified based on morphological criteria by trained field biologists prior to sample collection. Free-ranging rodents were captured using metal box traps transferred to a handling bag, weighed and samples collected. Non-human primates were cautiously captured, safely immobilized for post-capture processing (body mass and morphometric measurements, age class and sex). Sampling of animals was performed concurrently where cluster sampling was being conducted for humans at high-risk disease transmission interfaces. Oral and rectal swabs samples were collected as described in section 3.3.2.4 below. Following sample collection animals were released to the wild.

#### **3.3.2 Human**

##### **3.3.2.1 Recruitment criteria**

Community-based recruitment was used to enroll research subjects that is people living in, working in, or visiting targeted high-risk communities who have close contact with wildlife and livestock. The recruitment also considered any known or observed differences in animal contact or practices associated with racial/ethnic minority, religious or immigrant status. Cluster sampling was performed where concurrent sampling of animals was being conducted at high-risk disease transmission interfaces. From the enrolled research subjects oral and fecal swab samples were collected as described in section 3.3.2.4 below, following administration of informed consent from each participant.

##### **3.3.2.2 Criteria for inclusion of subjects**

All adults (18 years of age or older) who provided informed written consent, children (2 -17 years of age) accompanied by their parent or guardian who provided informed consent and children 12 years or older who provided assent and living in the high-risk interface with potentially high interaction with target species (bats, rodents and non-human primates) and experiencing flu-like symptoms in Laikipia County were included in the study.

### **3.3.2.3 Criteria for exclusion of subjects**

The following criteria was used to exclude subjects in the high-risk interface: Children <2 years of age, prisoners, individuals 18 years or older who refused or were unable to provide informed consent, individuals with physiologically or medically induced cognitive impairments and children 2 – 11 years old who were not accompanied by their parent or guardian or whose parent or guardian failed to provide informed consent, and children 12 years or older who was unable or unwilling to provide assent.

### **3.3.2.4 Sample types collected**

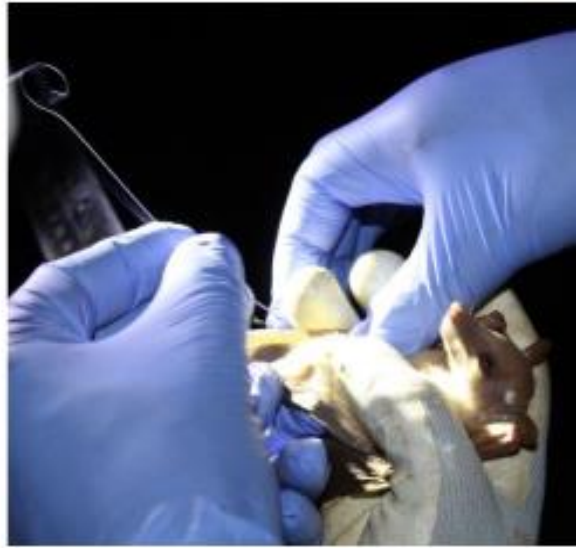
The samples collected were oral and rectal/fecal swabs, each collected in duplicate using polyester collection and transport swabs (BD Cat No. 220146). Use of rectal swabs was informed by studies where rectal swabs and four tissue specimens (liver, intestine, lung, and kidney) of Bats were positive for influenza virus and negative for the oral swab by RT-PCR. This suggested an infectious process rather than ingestion of infected viral matter via the gastrointestinal tract as the origin of vRNA (Tong *et al.*, 2012).

They were collected into cryovials containing approximately 500µL of TRIzol (Life Technologies). Samples in field were stored in liquid nitrogen and shipped to the laboratory where they were transferred to cold chain storage at -80°C. Extraction of RNA was carried out from 250µl of bats, non-human primates, rodents and humans' samples stored in TRIzol to obtain 50µl/g of RNA.





a



b



c



d

**Figure 6:** Showing sample collection from humans (a), bats (b) and non-human primates (c and cages for capturing non-human primates (d).

### **3.4 Detection and characterization of influenza viruses.**

#### **3.4.1 RNA extraction**

In a class II biosafety cabinet in a biosafety level II laboratory, extraction of viral genomic RNA was done from 250µl of rectal and oral polyester swab samples in TRIzol reagent using Direct-zol RNA extraction kit (Zymo Research, CA, USA) (Direct-zol®™ group). Briefly, swab samples in TRIzol stored at -80C were thawed on ice, vortexed, and centrifuged at 12000xg for 1 min. 250µl of the supernatant was then transferred to a RNase-free tube where 250µl of 95% ethanol. The mixture was added to a sterile Zymo-Spin™ Column in a collection tube for binding and washing with 400µl Direct-zol RNA pre-wash and 700µl RNA wash buffer, respectively followed by elution with 50µl DNase and RNase free water.

#### **3.4.2 cDNA synthesis**

Eight microliters of the extracted RNA were converted to complementary DNA using Invitrogen superscript III first strand synthesis (Applied Biosystems, Foster City, CA, USA) in ABI 7500 (Applied Biosystems, CA, USA) according to manufacturer's directions. To 8µl of extracted RNA, 1µl of random hexamers and dNTPs were added, the mixture was heated to 65°C for 5 minutes in a PCR machine then incubated on ice for 1 minute. To this mixture the following were added: 2µl 10x Reverse Transcriptase buffer, 4µl 25mM MgCl<sub>2</sub>, 2µl 0.1mM DTT, 1µl RNase OUT, 1µl (0.25 U/µL) superscript III RT cDNA synthesis. The mixture was then incubated with the following conditions in thermocycler; 25°C for 10 min, 50°C for 50 min, 85°C for 5 min and a final hold at 4°C. 1µl RNase H was added to the final product then incubation was done again a 37°C for 20 minutes. Random hexamers consist of a mixture of oligonucleotides representing all possible hexamer sequences to improve the sensitivity of cDNA synthesis.

For all samples RNA quality check was done targeting the 457bp mitochondrial cytochrome oxidase 1 gene in bats, rodents, non-human primates, human as described by (Twonzen *et al.*, 2008). Mitochondrial genes lack introns, limited recombination and exhibit haploid mode of inheritance hence they are preferred over nuclear genes. All cells contain numerous mitochondria DNA copies (Hebert *et al.*, 2009) hence in a limited sample successful extraction of mtDNA for PCR is possible.

The Cytochrome c oxidase I (COI) was amplified using forward primer in combination with reverse primer (appendix 2) (Twonzen *et al.*, 2008). The PCR conditions (per 25 $\mu$ l reaction) using platinum DNA polymerase (5U/ $\mu$ l) (Invitrogen, NY, USA) were 2.5 $\mu$ l of 10X PCR buffer, 0.75 $\mu$ l of 50M magnesium, 0.5 $\mu$ l of 10mM dNTP, 1 $\mu$ l of 20 $\mu$ M forward primer, 1 $\mu$ l of 10 $\mu$ M reverse primer, 0.1 $\mu$ l of 5g/l Taq, 18.15 $\mu$ l of Molecular grade water and 1 $\mu$ l of template (cDNA). Thermocycler (SimpliAmp™ Thermal Cycler, Applied Biosystems™, Foster City, CA) conditions were as follows: denaturation for 2 min at 94°C, followed by 50 cycles of denaturing for 30 secs at 94°C, annealing for 50 secs at 50°C, and extension time of 60 secs at 72°C. A final extension for 7 min at 72°C was performed, and the product held at 10°C. Sequencing was done by Macrogen Inc (Seoul, Korea).

### **3.4.3 Polymerase Chain Reaction.**

One microliters cDNA was submitted to first-round PCR amplification for detection influenza virus signature sequences (conserved region of about 400-bp) within the PB1 subunit of the polymerase, a conserved proteins across RNA viruses which allowed novel influenza viruses to be detected in Guatemala from fruit bats (Tong *et al.*, 2012).

A touch-down protocol was used for increased sensitivity and specificity, in a total reaction volume of 25 $\mu$ l using Invitrogen Platinum Taq kit (0.04 U/ $\mu$ L) according to manufacturer's instructions (Invitrogen, NY, USA). The forward and reverse primers (appendix 1) were used during the primary amplification with the following Thermocycler (SimpliAmp™ Thermal Cycler, Applied Biosystems™, Foster City, CA) conditions: temperature dependent activation of Taq polymerase at 95°C for 5 min; initial denaturation at 14 cycles of 95°C for 30 secs, the annealing temperature of the reaction was then decreased by 1°C every second for 35 secs from 65°C to a 'touchdown' at 51°C, at which 14 cycles of elongation were carried out (any change in melting temperature between the precise and improper annealing's act as an advantage of 2-fold per cycle, or 4-fold per °C, to the correct product). Initial elongation was then done at 72°C for 50 secs; followed by 35 cycles of denaturation at 95°C for 30 secs, annealing at 50°C for 30 secs, extension at 72°C for 50 secs, a final elongation 72°C for 7 minutes and a final hold at 10°C.

The primary amplification product was diluted 1:100 in water and 1 $\mu$ l was subjected to a secondary amplification, with similar conditions as used in round one PCR using nested primers (Round 1: F1234/1635R, Round 2: F1229/R1635) (appendix 2). The 400bp (approximately 30ng/0.5 $\mu$ g) PCR amplicons were resolved in a 1.5% agarose gel in Tris-acetate- EDTA buffer, containing ethidium bromide (10mg/ml) (Biotium, Hayward, CA, USA) and visualized under ultraviolet light. An external positive control was used during all the runs. The positive control is a influenza gene fragment of about 400bp cloned in a plasmid at a concentration of 100pg/ $\mu$ l.

#### **3.4.4 Agarose Gel electrophoresis and sequencing.**

1.5% agarose gel was prepared by adding 100ml of 1x TBE buffer to 1.5g agarose in a conical flask and heating the mixture at 100°C in a microwave for 5 minutes. Following cooling to 55°C for 3-4 minutes, 5 $\mu$ l intercalating dye (Ethidium bromide) was added to the gel (appendix 4). The gel was poured on a preset gel casting chamber for solidification at room temperature. The gel was transferred into an electrophoresis tank, running buffer was added and combs cautiously removed. 2 $\mu$ l 6X blue-orange loading dye (Invitrogen, NY, USA) was mixed with 10 $\mu$ l of PCR product in a parafilm and then loaded onto the wells. 100bp DNA marker (0.5  $\mu$ g/ $\mu$ L) (Invitrogen NY, USA) was pipetted into the first and last well. The gel electrophoresis was carried out at 100 volts for 90 minutes. The gel was retrieved from the electrophoresis chamber and viewed using an Alpha Imager gel documentation system (Alpha Innotech CA, USA). Positive samples determined by a band of expected size in comparison to the loaded positive control, were subjected to band clean up to recover the amplified DNA. Exosap-IT was used in clean-up of PCR products as described by Dugan *et al.*, 2002. Purified samples were then shipped to Macrogen Inc (Seoul, Korea) for sequencing.

### **3.5 Characterization and determination of relatedness.**

#### **3.5.1 Sequence analysis.**

Assembly of the nucleotide sequences of the forward and reverse runs was done in DNA Baser Sequence Assembler v3 (Heracle BioSoft SRL Romania, <http://www.DnaBaser>). The resulting nucleotide sequence were trimmed to obtain the correct open reading frame thereafter translation to amino acid sequence was done in BioEdit version 7.0.4 (Hall, 1999).

Following sequence editing in BioEdit version 7.0.4 (Hall, 1999) similarity search was carried out in blastn and p at <http://blast.ncbi.nlm.nih.gov> to determine the relationship between the influenza PB1 sequences deposited in the public databases and the obtained nucleotide, and translated amino acid sequences.

#### **3.5.2 Sequence alignment and Phylogenetic analysis**

Multiple sequence alignment of both the translated amino acid and nucleotide sequence data was carried out in MUSCLE (Edgar, 2004). The fastA alignment file was concatenated to nexus file for use in phylogenetic analysis.

Phylogenetic analysis of both the translated amino acid and nucleotide sequence data was performed in MrBayes a program for Bayesian inference (Ronquist and Huelsenbeck, 2003). The partial nucleotide and aminoacid fasta sequences data were converted into the Nexus file format using the Concatenator program (Pina-Martins and Paulo, 2008). Generalized time reversible (GTR) model parameters and priors were incorporated into the nexus file for execution of analyses in MrBayes (Tavaré, 1986). Analysis were run for 3 million generations by using eight chains and sampling every 1,000 generations.

Visualization and color-coding of the tree was done in FigTree (version 1.4.4) (<http://tree.bio.ed.ac.uk/software/figtree/>) to demonstrate tree topologies and corresponding taxa.

## CHAPTER FOUR

### 4.0 RESULTS

#### 4.1 Influenza virus PCR amplification.

A total of 400 bat samples (200 oral swabs, 200 rectal swabs), 382 samples (191 oral swabs and 191 rectal swabs) from baboons, 388 rodent samples (194 oral swabs and 194 rectal swabs) and 327 human samples (213 oral swabs and 114 fecal samples) were collected as shown in Table 2 and 3.

All the 388 oral and rectal samples obtained from rodents tested negative for influenza virus. Nine samples tested positive for influenza virus. These were eight oral samples; 5 from non-human primates, 3 from humans and one rectal sample from bat in the wet season of May 2018 and dry month of September 2017 respectively. A figure showing the PCR amplified PB1 partial gene segments is shown in Figure 8 for bat sample and figure 9 for human and non-human primates sample. The smears appearing in these figures 8 and 9 could have resulted from overloading of the wells, shearing of the cDNA, improper dilution of the sample or contamination with proteins. For the wet season this constituted 1.8% (n=428) of the total oral samples collected in 2018 and 1% (n=798) of the total samples collected in both seasons as shown in Table 2. For the dry season this constituted 0.24% (n=423) of the total rectal samples collected in 2017 and 0.14% (n=699) of the total rectal samples collected in both seasons as shown in Table 3. The five non-human primates infected with influenza virus were from *Papio anubis* while the bat was from *Chaerephone spp.*

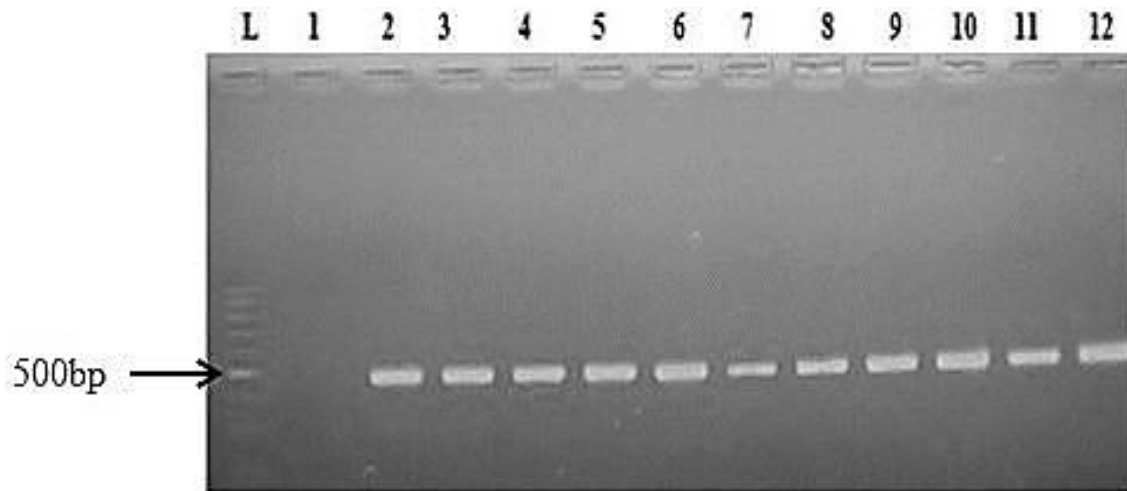
In animals, a mitochondrial gene; cytochrome C oxidase (COI) locus was used for RNA integrity confirmation (Hebert *et al.*, 2009). All samples were subjected to RNA quality check through amplification of COX1 gene to yield a band of approximately 457bp as shown in figure 7.

**Table 2:** Results of oral swabs PCR tests.

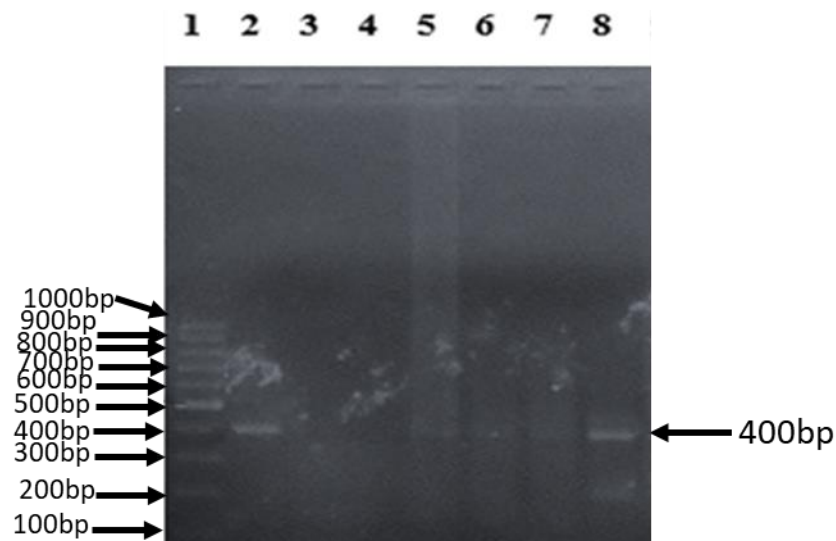
Season	Species	Oral swab test results	
		Positive influenza PB1	Negative
September 2017	Bats ( <i>Chaerephon spp</i> )	0	100
	Rodents( <i>Mus musculus</i> )	0	94
	Baboons ( <i>Papio anubis</i> )	0	76
	Humans	0	100
May 2018	Bats ( <i>Chaerephon spp</i> )	0	100
	Rodents ( <i>Mus musculus</i> )	0	100
	Baboons ( <i>Papio anubis</i> )	5	110
	Humans	3	110
<b>TOTAL</b>		<b>8(1%)</b>	<b>790</b>

**Table 3:** Results of rectal swabs PCR

Season	Species	Rectal swabs test results	
		Positive influenza PB1	Negative
September 2017	Bats ( <i>Chaerephon spp</i> )	1	99
	Rodents ( <i>Mus musculus</i> )	0	94
	Baboons ( <i>Papio anubis</i> )	0	76
	Humans	0	54
May 2018	Bats ( <i>Chaerephon spp</i> )	0	100
	Rodents ( <i>Mus musculus</i> )	0	100
	Baboons ( <i>Papio anubis</i> )	0	115
	Humans	0	60
<b>Total</b>		<b>1(0.14%)</b>	<b>698</b>

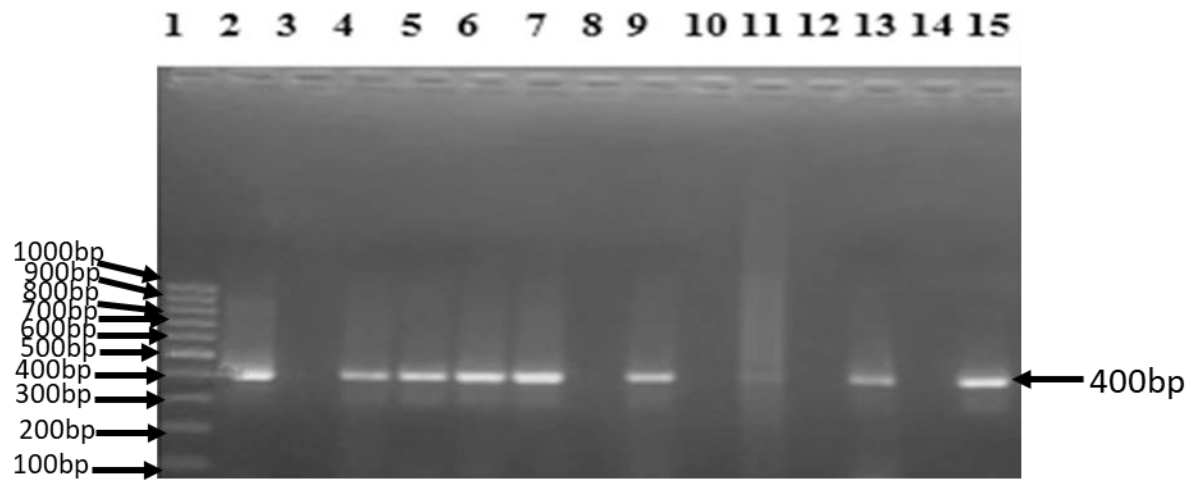


**Figure 7:** Agarose gel analysis of 457 bp cytochrome oxidase 1 gene in non-human primate, human, rodent and bat samples for barcoding.  
 (From left to right) Lane L, 1kb molecular ladder, Lane 1, empty well, Lane 2, 5, 8 bat samples, Lane 7 human sample and Lane 3, 4, 6, 10, 12 rodent samples.



**Figure 8:** Agarose gel analysis image of the PB1 amplicons from September 2017 bat (*Chaerephon spp*) sample.  
 Lane L, 1kb molecular ladder., Lane 2, positive control., Lane 3, empty well., Lane 4 No template control, Lane 8, sample 1 (bat). Lane 5,6,7,9 Bat samples.





**Figure 9:** Gel photo of a 400bp PB1 gene (segment 2) segment of influenza virus from May 2018 baboon and human samples.

Lane L, 1kb molecular marker., Lane 2, positive control., Lane 3, NTC., Lane 4-7, 9, baboon samples, Lane 8, 10, 12, 14, Empty wells and Lane 13, 15 human samples.

## 4.2 Influenza virus characterization

### 4.2.1 Sequences Analysis

The partial nucleotide sequences from the 400bp diagnostic PB1 amplicons were obtained and analyzed using the Basic Local Alignment Tool (BLASTn). The results obtained from this exercise showed seven out of the nine sample isolates were very similar to each other as shown in Table 4 and by BLASTn search were most closely related (>95%) to IAV PB1 genes as shown in figure 10. Sequences from two human samples were not successfully resolved.



Sequences producing significant alignments		Download	Manage columns	Show	100	?	
Description		Max Score	Total Score	Query Cover	E value	Per. Ident	Accession
<input checked="" type="checkbox"/>	<a href="#">Influenza A virus (A/American wigeon/Interior Alaska/9BM2501R1/2009(H3N8)), polymerase PB1 (PB1) and PB1-F2 protein (PB1-F2), genes_c</a>	576	576	97%	3e-160	98.78%	CY130338.1
<input checked="" type="checkbox"/>	<a href="#">Influenza A virus (A/mallard/Interior Alaska/7MP1771R1/2007(H4N6)), segment 2, complete sequence</a>	576	576	97%	3e-160	98.78%	CY078897.1
<input checked="" type="checkbox"/>	<a href="#">Influenza A virus (A/northern shoveler/Interior Alaska/7MP1670/2007(H3N8)), segment 2, complete sequence</a>	576	576	97%	3e-160	98.78%	CY077354.1
<input checked="" type="checkbox"/>	<a href="#">Influenza A virus (A/mallard/Interior Alaska/7MP0512/2007(H4N6)), segment 2, complete sequence</a>	576	576	97%	3e-160	98.78%	CY077268.1

Figure 10: Illustration to show similarity by BLASTn of detected influenza virus with sequenced from the database.

The detected influenza virus from Laikipia County bat, baboons and humans were compared to influenza virus sequences deposited in the public database from Kenya, Uganda, Nigeria, Cameroon and Egypt. These countries have experienced influenza virus outbreaks in the recent past particularly the persistent HPAIV virus, H5N1 which reassorts into other subtypes. This is due to inadequate biosecurity compliance during poultry vaccination, at poultry farms and live bird markets, multispecies livestock farming, and husbandry methods, transboundary transmission via transcontinental migratory birds and poultry trades (Fasanmi *et al.*, 2017)

In addition, since the samples were collected within the same geographical location phylogenetic characterization was also carried out following Multiple Sequencing analysis, (figure 11 and 12) for both nucleotide (figure 11) and translated amino acid sequences (figure 12). MSA revealed great differences between bat influenza virus and viruses from other taxa (non-human primates and humans) as by the pairwise comparison of the sequences for both translated.

#### 4.2.2 Sequence similarity and identity

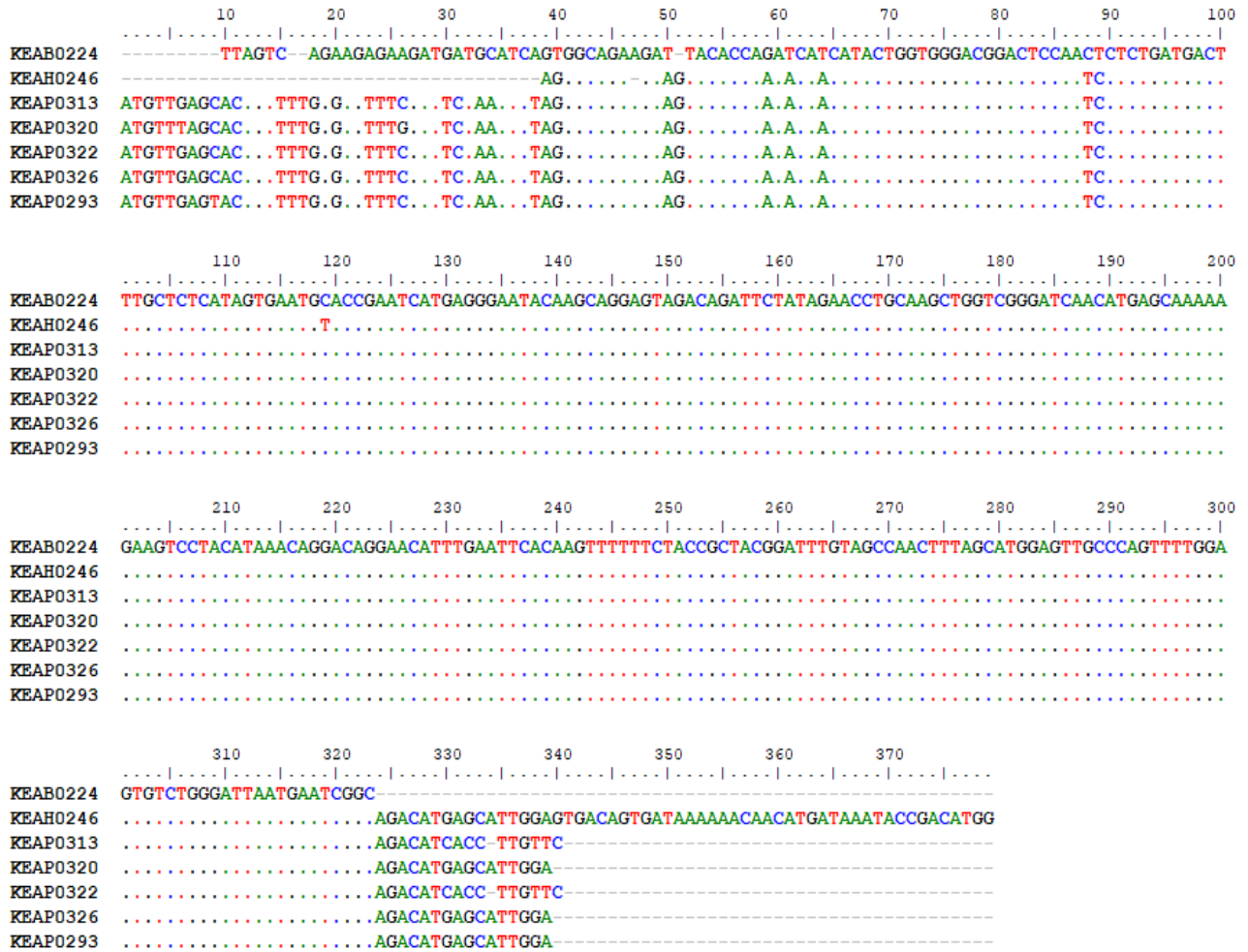
**Table 4:** Showing the nucleotide identity (%) and amino acid identity (%), above and below the diagonal receptively.

Pairwise comparison of the 400 pb1 segment of Influenza viruses.							
Virus	KEAB0224	KEAH0246	KEAP0313	KEAP0320	KEAP0322	KEAP0326	KEAP0293
KEAB0224	ID	74.4%	85.2%	85.2%	85.2%	85.2%	85.2%
KEAH0246	72.1%	ID	77.5%	78.8%	77.5%	78.8%	78.8%
KEAP0313	73.0%	76.9%	ID	97.6%	100.0%	98.2%	97.9%
KEAP0320	76.1%	76.1%	94.6%	ID	97.6%	99.4%	99.1%
KEAP0322	73.0%	76.9%	100.0%	94.6%	ID	98.2%	97.9%
KEAP0326	76.1%	76.9%	96.4%	98.2%	96.4%	ID	99.7%
KEAP0293	76.1%	76.9%	96.4%	98.2%	96.4%	100.0%	ID

KEAP for non-human primates, KEAH for human, and KEAB for bats.

The above pairwise comparison was used to determine relationships among detected influenza viruses where by nucleotide sequence identities >96% could indicated viruses belonging to the same species or are closely related while <96% could suggest viruses from different species and distantly related (Batts, *et al.*, 2017).

### 4.2.3 Multiple Sequence Alignment



**Figure 11:** PB1 nucleotide multiple sequences alignment (conservation plot) of Laikipia samples.

KEAP non-human primates, KEAH human, and KEAB bats.

```

KEAH0246 ...R.....AEKYTKTTYWWDGLQSSDDFALIVNVPNHEGIQAGVDRFYRTCKLVGINMSKKKSYINRTGTFEFTSFFYRYGFVANFSMEL
KEAB0224 LVRREDDASV...AEDYTRSSYWWDGLQLSDDFALIVNAPNHEGIQAGVDRFYRTCKLVGINMSKKKSYINRTGTFEFTSFFYRYGFVANFSMEL
KEAP0313 MLSTVLGVSILNLGQKKYTKTTYWWDGLQSSDDFALIVNAPNHEGIQAGVDRFYRTCKLVGINMSKKKSYINRTGTFEFTSFFYRYGFVANFSMEL
KEAP0320 MFSTVLGVWILNLGQKKYTKTTYWWDGLQSSDDFALIVNAPNHEGIQAGVDRFYRTCKLVGINMSKKKSYINRTGTFEFTSFFYRYGFVANFSMEL
KEAP0322 MLSTVLGVSILNLGQKKYTKTTYWWDGLQSSDDFALIVNAPNHEGIQAGVDRFYRTCKLVGINMSKKKSYINRTGTFEFTSFFYRYGFVANFSMEL
KEAP0326 MLSTVLGVSILNLGQKKYTKTTYWWDGLQSSDDFALIVNAPNHEGIQAGVDRFYRTCKLVGINMSKKKSYINRTGTFEFTSFFYRYGFVANFSMEL
KEAP0293 MLSTVLGVSILNLGQKKYTKTTYWWDGLQSSDDFALIVNAPNHEGIQAGVDRFYRTCKLVGINMSKKKSYINRTGTFEFTSFFYRYGFVANFSMEL

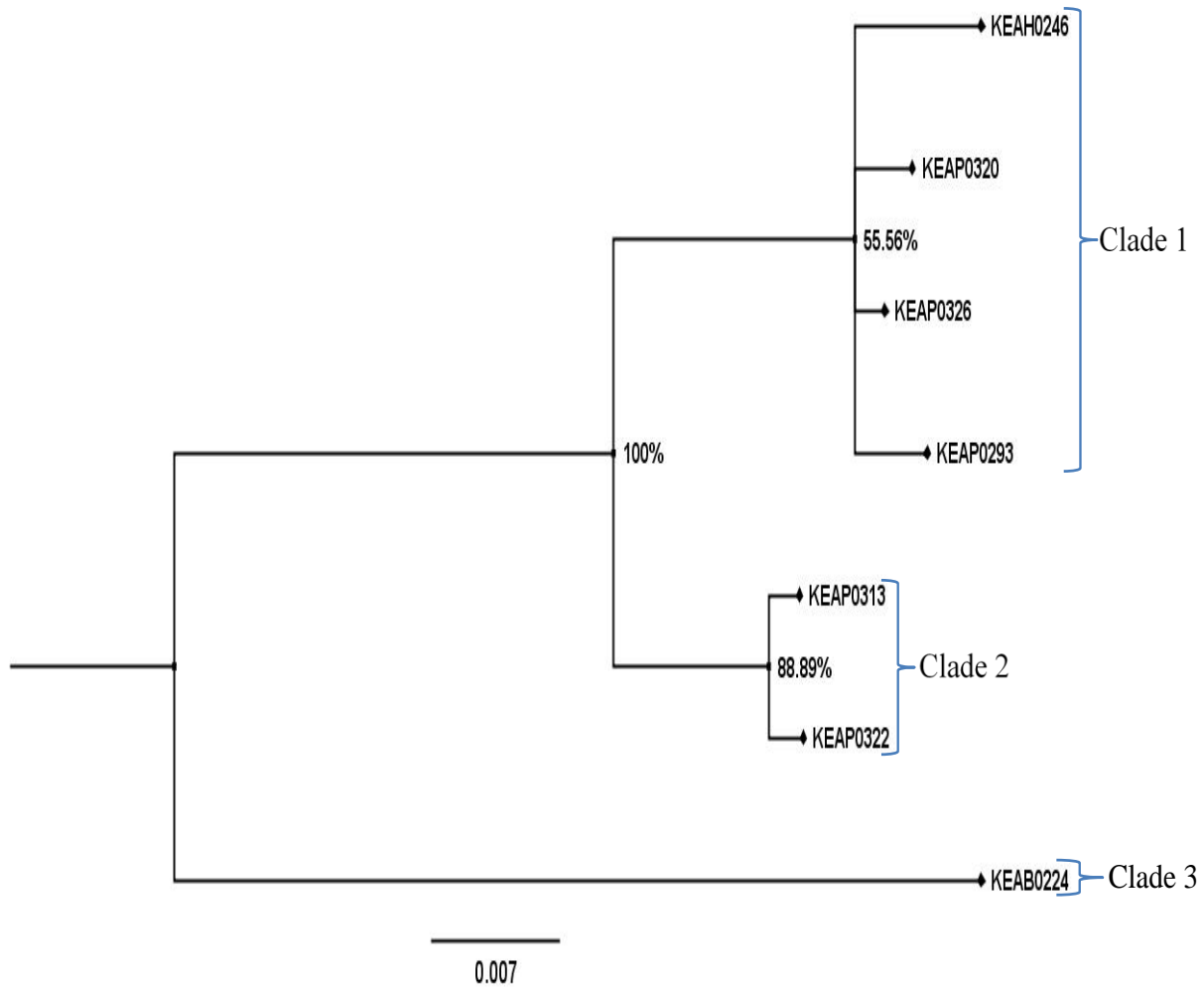
KEAH0246 PSFGVSGINESADMSIGVTVIKNNMINTDM
KEAB0224 PSFGVSGINES.....
KEAP0313 PSFGVSGINESADITLF.....
KEAP0320 PSFGVSGINESADMSIG.....
KEAP0322 PSFGVSGINESADITLF.....
KEAP0326 PSFGVSGINESADMSIG.....
KEAP0293 PSFGVSGINESADMSIG.....

```

**Figure 12:** PB1 translated amino acid multiple sequences alignment showing the motif III (red bracket) and motif IV (blue bracket).

KEAP non-human primates, KEAH human, and KEAB bats.

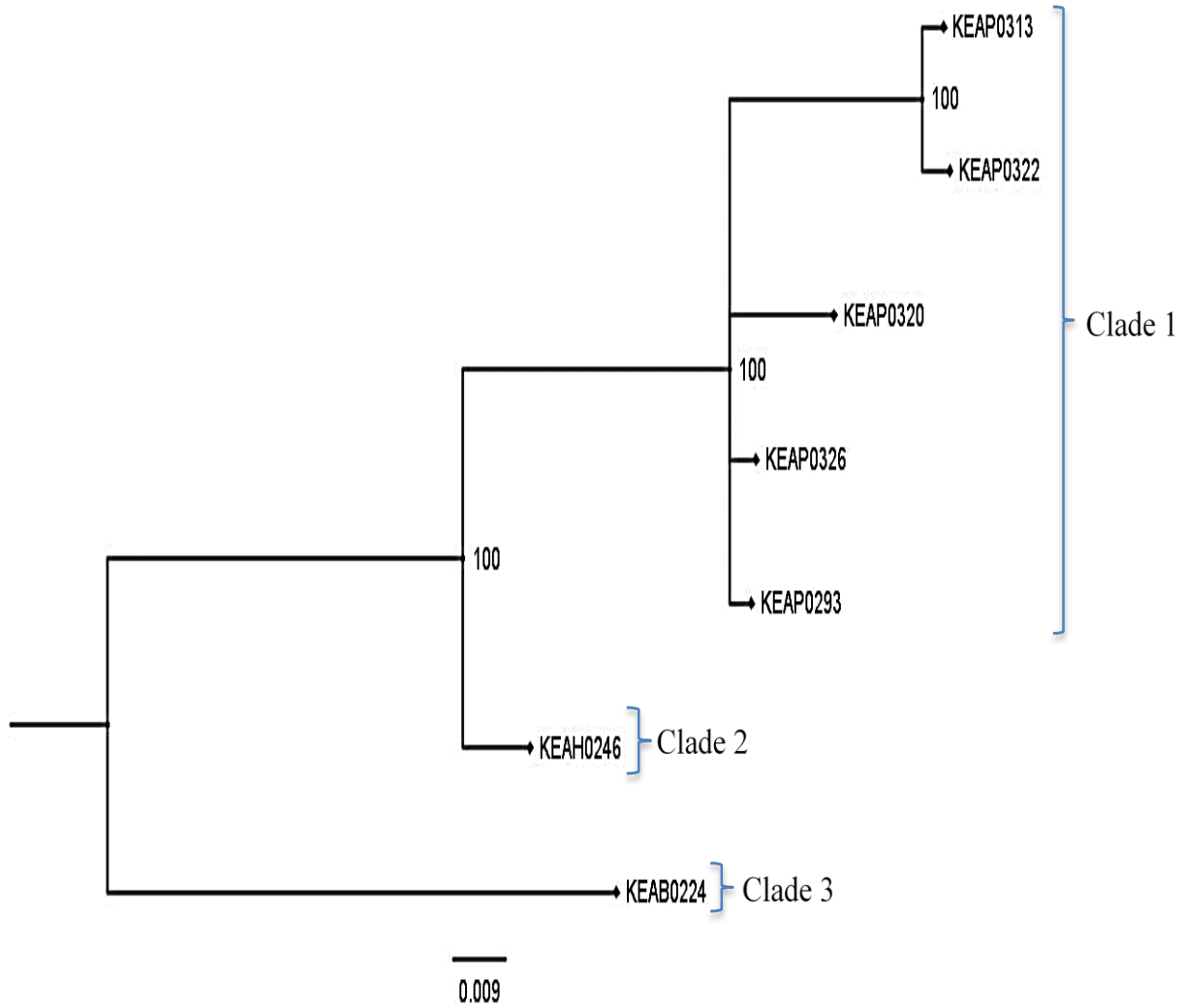
#### 4.2.4 Phylogenetic characterization



**Figure 13:** Phylogenetic tree of partial nucleotide sequences (PB1) of Laikipia samples.

KEAP, non-human primates; KEAH, humans; and KEAB, bats.

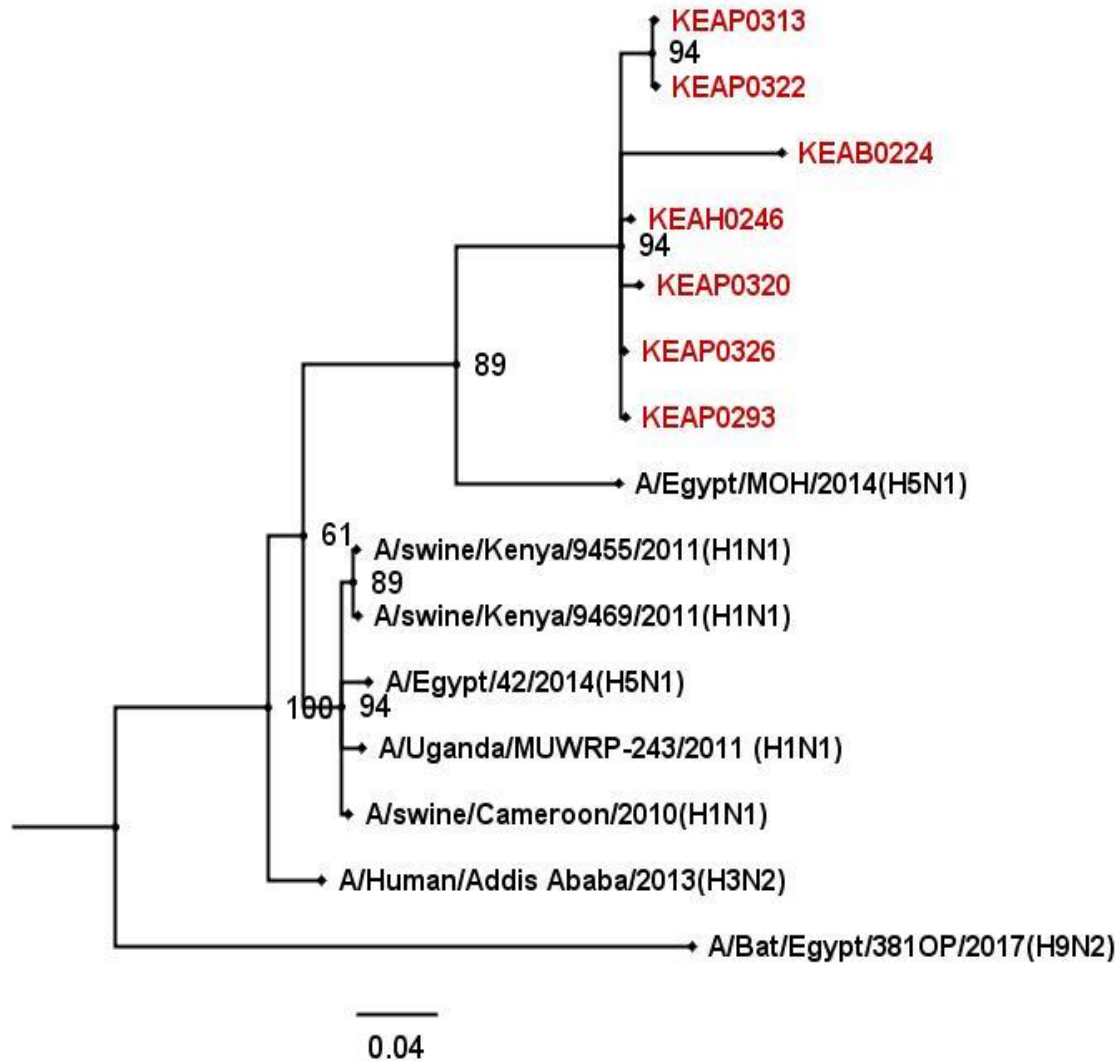
Figure 12 shows the difference (based on partial PB1 sequences) within detected influenza viruses in Laikipia county at the nucleotide level. The tree was constructed in MrBayes. Number at the node shows percentage of posterior probabilities. All branch lengths are equal to the amount of substitutions per site. Midpoint rooting was used to root the tree.



**Figure 14:** Phylogenetic tree of translated amino acid PB1 sequences (ORF2) of Laikipia samples.

The tree was generated in MrBayes. The scale bar indicates substitutions per site. KEAP, non-human primates; KEAH, humans; and KEAB, bats; ORF, open reading frame.

Figure 13 show the difference (based on partial PB1 sequences) within detected influenza viruses in Laikipia county for amino acid. Percentage posterior probabilities are indicated at the nodes. All branch lengths are equal to the amount of substitutions per site.

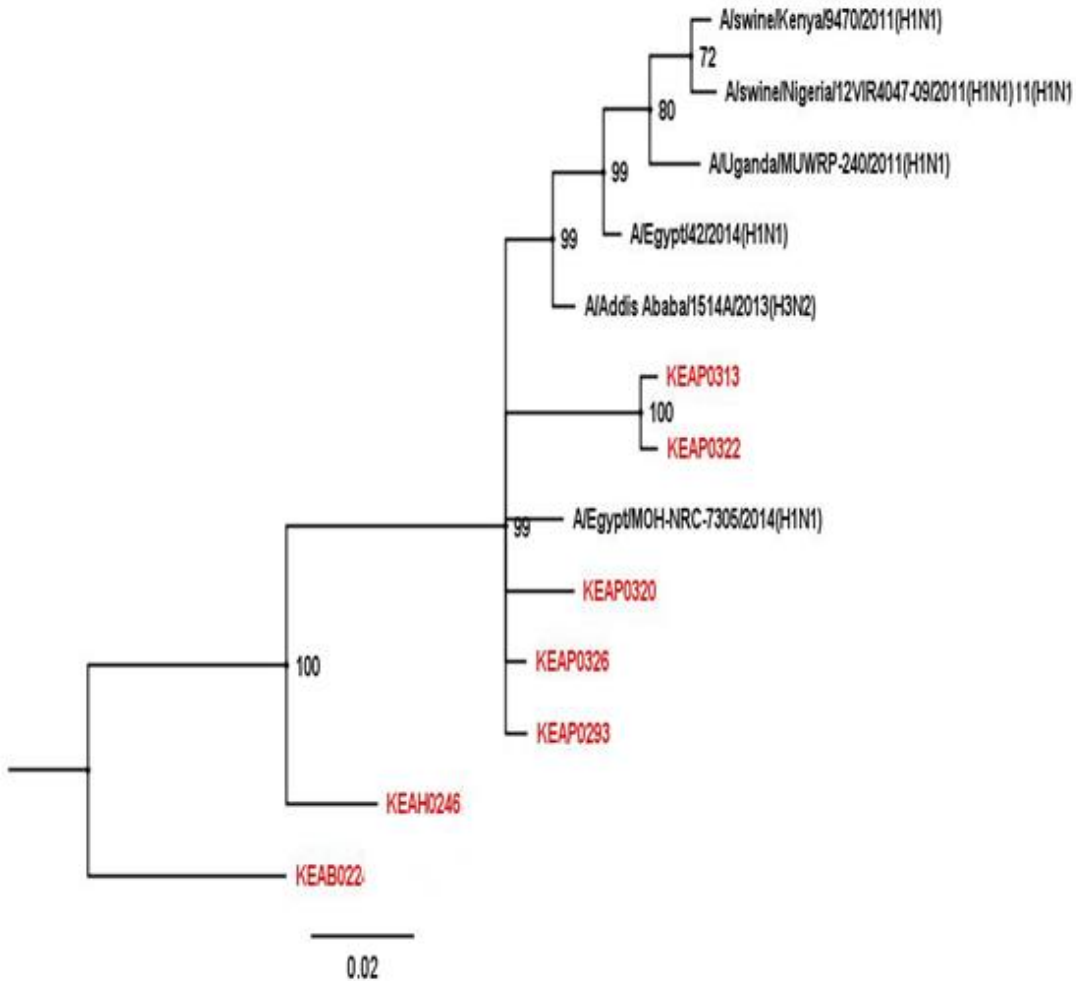


**Figure 15:** Phylogenetic tree inferred from PB1 nucleotide sequences of Laikipia samples and related sequences from the database.

KEAP, non-human primates; KEAH, humans; and KEAB, bats

The phylogeny shows the differences at the nucleotide level between detected influenza viruses in Laikipia county (red color) and related influenza viruses (black color) from the database, Percent posterior probabilities are shown in the nodes. The scale bar indicates substitutions per site. The trees were generated in MrBayes (version 3.1.2), applying the GTR amino acid substitution model.





**Figure 16:** Phylogenetic tree of translated PB1 amino acid sequences of Laikipia samples.

Phylogenetic tree was inferred with representative PB1 sequences from Uganda, Ethiopia, Egypt, and Nigeria (black). Laikipia samples are shown in red. It shows the differences at the amino acid level between detected influenza viruses in Laikipia county (red color) and related influenza viruses (black color), posterior probability values are indicated in the nodes. The scale bar indicates substitutions per site. KEAP, non-human primates; KEAH, humans; and KEAB, bats.

Phylogenetic characterization for comparison of detected Laikipia influenza viruses with global (Africa) circulating influenza viruses was carried out using both the partial nucleotide and translated amino acid sequences. The phylogenetic tree of partial nucleotide sequences and translated amino acid sequences showed similar topologies (figures 13 and 14).

In figure 13 and 14 bat sample appeared as a root. The phylogeny of the PB1 gene was moderately narrow, with relatively small polytomies observed. The maximum depth of the tree (from root to furthest tip) being 2-6 nodes indicating lack of phylogenetic resolution and close relationships.

The phylogenetic analysis of the Laikipia influenza viruses (figure 15 and 16) showed that they were interspersed with sequences from selected countries. It was also observed that the bat sample appeared to be distantly related from the phylogenetic tree inferred from the translated amino acid sequences and related sequences in the database (figure 16). Two non-human primate viruses indicated close relationship (KEAP0313 and KEAP0322) ( $pp \geq 70\%$ ) in all the trees (figures 13-16).

Non-human primate's influenza viruses KEAP0313 and KEAP0322 clustered closely forming a monophyletic single clade; clade 2 and clade 3 in figure 13 and 14 respectively. This clade is sister group to three non-human primate sequences (KEAP0326, 0320 and 0293).

The phylogenetic tree; Figure 14 shows a very close relationship between the human influenza virus KEAH0246 and the following non-human primates influenza viruses KEAP0293 and 0320 but different as it appears as an out-group of clade 2. Because of the paucity of influenza virus molecular information on non-human primates a regional comparison (Figure 15 and 126) was done but the observed clustering in the previous lone trees (Figures 13 and 14) was still evident.

## CHAPTER FIVE

### 5.0 DISCUSSION, CONCLUSION AND RECOMMENDATION

This study detected nine influenza viruses by PCR and following sequencing and blasting seven were related to influenza A virus. The low detection rate (0.1-1%) of influenza viruses is similar to studies on selected domestic animals' dogs, swine, ducks, chicken, geese, cats and turkeys in Kenya where 0.2% of 2448 samples collected in Asembo and 0.6% of 1716 of samples collected in Kibera were positive, indicated low prevalence for zoonotic influenza A virus (Munyua 2015).

Multiple sequencing of the translated nucleotide sequence revealed conserved sequences (figure 11); Motif III (red bracket) and IV (blue bracket) characteristic of Influenza viruses PB1 RNA dependent polymerase domain (Chu *et al.*, 2012; Poch O *et al.*, 1989; Lukarska *et al.*, 2017). Motif III is involved the replicase and transcriptase activity (Biswas & Nayak, 1994). It is also important in template recognition, phosphate and metal binding, and various catalytic functions (Chu *et al.*, 2012. Motif IV contains a Lysine residue at position 480 where substitution to arginine, increase the replication and transcription of PB1.

Bat Influenza virus was detected in one rectal swab at high-risk interface area this is similar to studies conducted by (Tong *et al.*, 2012). This detection of IAV in rectal swabs, shows potential shedding in feces. Hence, potential infection of humans or other animal species is possible following indirect transmission of the virus. In addition, Bat influenza virus appears genetically distinct in the phylogenetic (figure 14 and 15). This could suggested that the Bat virus was more ancient compared to the human. This ancientness is supported by studies amongst avian and Bat viruses using the HA and NA genes that showed that influenza virus associated with bats are older and highly divergent phylogenetically from avian influenza viruses (Brunotte *et al.*, 2016).

All rodents sampled in the study were negative for influenza virus. This is similar to other findings in Africa, where influenza virus was not detected in oral swabs of rodents interacting with birds infected with LPAIV by PCR (Shriner *et al.*, 2012). Frequent contact of rodents with household animals which spread influenza to humans such as cats indicate a potential route of infection (Belser *et al.*, 2017). In addition, mice ciliated cells contain  $\alpha$ 2,3-linked sialic acid receptors that preferentially bind avian IAV strains over human origin IAVs (Ibricevic *et al.*, 2006) hence this study pushes for more investigation in areas around Kenya that harbor high population of rodents that interact with humans.

One species of non-human primates (*Papio anubis*) was sampled in this study and five tested positive for influenza virus suggesting that non-human primates may be susceptible to the virus in nature. This is consistent with molecular studies done by Karlsson et al which revealed that seasonal human IAV and emerging avian influenza viruses can naturally infect non-human primates (macaques) interacting with humans although the prevalence could be low (Karlsson *et al.*, 2012). Detection of IAV in non-human primates warrants further surveillance given the close relationship between humans and NHPs at high risk interface areas.

Although influenza viruses detected in this study had close similarity to PB1 of influenza A virus based on the blast results, characterization of the Hemagglutinin was not carried out to ascertain the subtype of the detected influenza virus.

Influenza virus was detected in bats, humans and non-human primates in Laikipia county, Kenya. The detection was in rectal swabs for bats and oral swabs for the other taxa. The influenza viruses detected were apperead to be closely related Influenza A virus genus in the GenBank. In phylogentic analysis non-human primates influenza virus were closely related while bat influenza virus appeared distinct.

Larger-scale surveillance at livestock-wildlife-human overlap locations is needed to understand the diversity of influenza virus in bats and non human primates in Laikipia County this should be supported by full genome analysis to aid in subtying and characterization of the detected viruses to understand their origins and evolution pattern.

## REFERENCES

**Allen, T., Murray, K. A., Zambrana-Torrel, C., Morse, S. S., Rondinini, C., Di Marco, M., Breit, N., Olival, K.J. & Daszak, P.** (2017). Global hotspots and correlates of emerging zoonotic diseases. *Nature communications*, 8(1), 1-10.

**Batts, W. N., LaPatra, S. E., Katona, R., Leis, E., Ng, T., Briec, M., Breyta, R. B., Purcell, M. K., Conway, C. M., Waltzek, T. B., Delwart, E., & Winton, J. R.** (2017). Molecular characterization of a novel orthomyxovirus from rainbow and steelhead trout (*Oncorhynchus mykiss*). *Virus research*, 230, 38–49. <https://doi.org/10.1016/j.virusres.2017.01.005>

**Biswas, S. K., & Nayak, D. P.** (1994). Mutational analysis of the conserved motifs of influenza A virus polymerase basic protein 1. *Journal of virology*, 68(3), 1819-1826.

**Campos, A. C. A., Góes, L. G. B., Moreira-Soto, A., de Carvalho, C., Ambar, G., Sander, A. L., Fischer, C., da Rosa, A.R., de Oliveira, D.C., Kataoka, A.P.G & Pedro, W. A.** (2019). Bat influenza A (HL18NL11) virus in fruit bats, Brazil. *Emerging infectious diseases*, 25(2), 333.

**Chu, C., Fan, S., Li, C., Macken, C., Kim, J. H., Hatta, M., & Kawaoka, Y.** (2012). Functional analysis of conserved motifs in influenza virus PB1 protein. *PLoS One*, 7(5), e36113.

**Cleaveland, S., Laurenson, M. K., & Taylor, L. H.** (2001). Diseases of humans and their domestic mammals: pathogen characteristics, host range and the risk of emergence. *Philosophical Transactions of the Royal Society of London. Series B: Biological Sciences*, 356(1411), 991-999.

**Colman, P. M.** (1989). Neuraminidase. In *The influenza viruses* (pp. 175-218). *Springer*, Boston, MA.

**Cotter, C. R., Jin, H., & Chen, Z.** (2014). A single amino acid in the stalk region of the H1N1pdm influenza virus HA protein affects viral fusion, stability and infectivity. *PLoS pathogens*, 10(1), e1003831.

**Cox, N.J., Ziegler, T.,** 2003, Influenza viruses, In: Murray, P.R.B., E, J; Jorgensen, J, H; Pfaller, M, A; Tenover, R,H (Ed.) *Manual of clinical microbiology*. ASM Press, Washington.

**Cunningham, A. A., Daszak, P., & Wood, J. L.** (2017). One Health, emerging infectious diseases and wildlife: two decades of progress? *Philosophical Transactions of the Royal Society B: Biological Sciences*, 372(1725), 20160167.

**Das, K., Aramini, J. M., Ma, L. C., Krug, R. M., & Arnold, E.** (2010). Structures of influenza A proteins and insights into antiviral drug targets. *Nature structural & molecular biology*, 17(5), 530.

**de Castro Martin, I. F., Fournier, G., Sachse, M., Pizarro-Cerda, J., Risco, C., & Naffakh, N.** (2017). Influenza virus genome reaches the plasma membrane via a modified endoplasmic reticulum and Rab11-dependent vesicles. *Nature communications*, 8(1), 1396.

**Dias, A., Bouvier, D., Crepin, T., McCarthy, A.A., Hart, D.J., Baudin, F., Cusack, S., Ruigrok, R.W.** (2009). The cap-snatching endonuclease of influenza virus polymerase resides in the PA subunit. *Nature* 458, 914-918.

**Digard, P., Blok, V.C., Inglis, S.C.** (1989). Complex formation between influenza virus polymerase proteins expressed in *Xenopus* oocytes. *Virology* 171, 162-169.

**Emukule, G. O., Paget, J., van der Velden, K., & Mott, J. A.** (2015). Influenza-associated disease burden in Kenya: a systematic review of literature. *PloS one*, 10(9), e0138708.

**Fasanmi, O. G., Odetokun, I. A., Balogun, F. A., & Fasina, F. O.** (2017). Public health concerns of highly pathogenic avian influenza H5N1 endemicity in Africa. *Veterinary world*, 10(10), 1194–1204. <https://doi.org/10.14202/vetworld.2017.1194-1204>

**Fodor, E.** (2013). The RNA polymerase of influenza A virus: mechanisms of viral transcription and replication. *Acta virologica*, 57(2), 113-122.

**Fuller, T. L., Gilbert, M., Martin, V., Cappelle, J., Hosseini, P., Njabo, K. Y., Abdel Aziz, S., Xiao, X., Daszak, P., & Smith, T. B.** (2013). Predicting hotspots for influenza virus reassortment. *Emerging infectious diseases*, 19(4), 581–588.

**Gonzalez, S., Zurcher, T., Ortin, J.** (1996). Identification of two separate domains in the influenza virus PB1 protein involved in the interaction with the PB2 and PA subunits: a model for the viral RNA polymerase structure. *Nucleic Acids Res* 24, 4456-4463.

**Graef, K. M., Vreede, F. T., Lau, Y., McCall, A. W., Carr, S. M., Subbarao, K., & Fodor, E.** (2010). The PB2 Subunit of the Influenza Virus RNA Polymerase Affects Virulence by Interacting with the Mitochondrial Antiviral Signaling Protein and Inhibiting Expression of Beta Interferon. *Journal of Virology*, 84(17), 8433-8445. doi:10.1128/jvi.00879-10.

**Hall, T.** (2007). BioEdit v7 <http://www.mbio.ncsu.edu/BioEdit/BioEdit.html>.

**He, C. Q., Han, G. Z., Wang, D., Liu, W., Li, G. R., Liu, X. P., & Ding, N. Z.** (2008). Homologous recombination evidence in human and swine influenza A viruses. *Virology*, 380(1), 12-20.

**Huang S, Chen J, Chen Q, Wang H, Yao Y, Chen J, et al** (2013). A second CRM1- dependent nuclear export signal in the influenza A virus NS2 protein contributes to the nuclear export of viral ribonucleoproteins. *Journey of Virology* 87:767–78. doi:10.1128/JVI.06519-11

**Jones, K., Patel, N., Levy, M., Storeygard, A., Balk, D., Gittleman, J. and Daszak, P.** (2008). Global trends in emerging infectious diseases. *Nature*, 451(7181), pp.990-993.

**Karesh, W. B., Dobson, A., Lloyd-Smith, J. O., Lubroth, J., Dixon, M. A., Bennett, M., Aldrich, S., Harrington, T., Formenty, P., Loh, E.H & Machalaba, C. C.** (2012). Ecology of zoonoses: natural and unnatural histories. *The Lancet*, 380(9857), 1936-1945.

**Karlsson, E. A., Engel, G. A., Feeroz, M. M., San, S., Rompis, A., Lee, B. P. H., Eric Shaw & Heidrich, J.** (2012). Influenza virus infection in nonhuman primates. *Emerging infectious diseases*, 18(10), 1672.

**Katz, M. A., Muthoka, P., Emukule, G. O., Kalani, R., Njuguna, H., Waiboci, L. W., Ahmed, J.A., Bigogo, G., Feikin, D.R., Njenga, M.K. & Breiman, R. F.** (2014). Results from the first six years of national sentinel surveillance for influenza in Kenya, July 2007–June 2013. *PloS one*, 9(6), e98615.

**Kivai S.** (2010). Ruffords small grant report [http://ruffordsmallgrant.org/rgs/projects/stanislaus\\_mulu\\_kivai](http://ruffordsmallgrant.org/rgs/projects/stanislaus_mulu_kivai)

**Kruse, H., Kirkemo, A. M., & Handeland, K.** (2004). Wildlife as source of zoonotic infections. *Emerging infectious diseases*, 10(12), 2067.

**Lamb, R.A. & Krug, R.M.** (2001) Orthomyxoviridae: the viruses and their replication in *Fields Virology 4th edn.* (ed. Knipe, D.M. & Howley, P.M.) 1487–1532 (Lippincott, Williams & Wilkins, Philadelphia, USA,

**Lee, K. H., Gordon, A., Shedden, K., Kuan, G., Ng, S., Balmaseda, A., & Foxman, B.** (2019). The respiratory microbiome and susceptibility to influenza virus infection. *PLoS one*, 14(1), e0207898.

**Lee, K., Lee, E. K., Lee, H., Heo, G. B., Lee, Y. N., Jung, J. Y., Bae, Y.C., So, B., Lee, Y.J. and... & Choi, E. J.** (2018). Highly Pathogenic Avian Influenza A (H5N6) in Domestic Cats, South Korea. *Emerging infectious diseases*, 24(12), 2343.

**Lukarska, M., Fournier, G., Pflug, A., Resa-Infante, P., Reich, S., Naffakh, N., & Cusack, S.** (2017). Structural basis of an essential interaction between influenza polymerase and Pol II CTD. *Nature*, 541(7635), 117.

**Ma, W., Kahn, R. E., & Richt, J. A.** (2009). The pig as a mixing vessel for influenza viruses: human and veterinary implications. *Journal of molecular and genetic medicine: an international journal of biomedical research*, 3(1), 158.

**Matheka, D. M., Mokaya, J., & Maritim, M.** (2013). Overview of influenza virus infections in Kenya: past, present and future. *The Pan African Medical Journal*, 14.



**Maier, H.J., Kashiwagi, T., Hara, K. & Brownlee, G.G.** (2008) Differential role of the influenza A virus polymerase PA subunit for vRNA and cRNA promoter binding. *Virology* 370, 194–204.

**Malanoski, A. P., & Lin, B.** (2013). Evolving gene targets and technology in influenza detection. *Molecular diagnosis & therapy*, 17(5), 273–286. <https://doi.org/10.1007/s40291-013-0040-9>

**Margine, I., & Krammer, F.** (2014). Animal models for influenza viruses: implications for universal vaccine development. *Pathogens*, 3(4), 845-874.

**Mettenleiter, T. C., & Sobrino, F.** (2008). Animal viruses: *Molecular biology. Norfolk: Caister Academic*, 253-301.

**Min, J., Wang, J., Su, W., Gao, S., Luo, J., Zhang, M., Xie, L., Liu, S., Liu, X., Chen, Y., Jia, Y., Zhang, H., Ding, H., & He, H.** (2014). Relationship between domestic and wild birds in live poultry market and a novel human H7N9 virus in China. *The Journal of Infectious Diseases*, 209(1), 34-37. 2006

**Monto, A. S., & Fukuda, K.** (2019). Lessons From Influenza Pandemics of the Last 100 Years. *Clinical Infectious Diseases*. doi:10.1093/cid/ciz803

**Morens, D. and Fauci, A.,** (2013). Emerging Infectious Diseases: Threats to Human Health and Global Stability. *PLoS Pathogens*, 9(7), p.e1003467.

**Munyua, P. M.** (2015). Identification and Characterization of Influenza A Viruses among Domestic Animals in Selected Sites in Kenya (*Doctoral dissertation*, University of Nairobi).

**Murphy, F. A.** (2008). Emerging zoonoses: the challenge for public health and biodefense. *Preventive veterinary medicine*, 86(3), 216-223.

**Muthoka** (2013) Influenza Epidemiology in Kenya. Available at [https://www.teampsa.com/anise/2012/pres/WEDFEB1/InfluenzaSurvUpdates/Muthoka\\_Influenza%20Epidemiology%20in%20Kenya.pdf](https://www.teampsa.com/anise/2012/pres/WEDFEB1/InfluenzaSurvUpdates/Muthoka_Influenza%20Epidemiology%20in%20Kenya.pdf). Accessed 17th March 2013.

**Pflug, A., Guilligay, D., Reich, S., & Cusack, S.** (2014). Structure of influenza A polymerase bound to the viral RNA promoter. *Nature*, 516(7531), 355-360.

**Ronquist, F., & Huelsenbeck, J. P.** (2003). MrBayes 3: Bayesian phylogenetic inference under mixed models. *Bioinformatics*, 19(12), 1572-1574.

**Rossman, J. S., & Lamb, R. A.** (2011). Influenza virus assembly and budding. *Virology*, 411(2), 229-236.

**Schrenzel, M. D., Tucker, T. A., Stalis, I. H., Kagan, R. A., Burns, R. P., Denison, A. M., Drew, C. P., Paddock, C. D., & Rideout, B. A.** (2011). Pandemic (H1N1) 2009 virus in 3 wildlife species, San Diego, California, USA. *Emerging Infectious Diseases*, 17(4), 747-749.

**Schweiger, B., Bruns, L., & Meixenberger, K.** (2006). Reassortment between human A(H3N2) viruses is an important evolutionary mechanism. *Vaccine*, 24(44-46), 6683-6690.

**Skehel, J.J. & Wiley, D.C.** (2000). Receptor binding and membrane fusion in virus entry: the influenza hemagglutinin. *Annu. Rev. Biochem.* 69, 531–569

**Sooryanarain, H., & Elankumaran, S.** (2015). Environmental Role in Influenza Virus Outbreaks. *Annual Review of Animal Biosciences*, 3(1), 347–373.

**Stauffer, S., Feng, Y., Nebioglu, F., Heilig, R., Picotti, P., & Helenius, A.** (2014). Stepwise priming by acidic pH and a high K<sup>+</sup> concentration is required for efficient uncoating of influenza A virus cores after penetration. *Journal of virology*, 88(22), 13029-13046.

**Stevens, J., Blixt, O., Tumpey, T.M., Taubenberger, J.K., Paulson, J.C., Wilson, I.A.,** (2006), Structure and receptor specificity of the hemagglutinin from an H5N1 influenza virus. *Science* 312, 404-410.

**Stouffer, A.L, Germina, K. Fuller M.** (2008). Structural basis for the function and inhibition of an influenza virus proton channel. *Nature* 451, 596–599.

**Sui, J., Cham, K. Zhu, C** (2009). Structural and functional bases for broad-spectrum neutralization of avian and human influenza A viruses. *Nature. Structural. Molecular. Biology.* 16, 265–273.

**Sutton, T. C., Chakraborty, S., Mallajosyula, V. V., Lamirande, E. W., Ganti, K., Bock, K. W., Moore, I.N., Varadarajan, R. & Subbarao, K.** (2017). Protective efficacy of influenza group 2 hemagglutinin stem-fragment immunogen vaccines. *Vaccines*, 2(1), 35.

**Suzuki, T., Takahashi, T., Guo, C. T., Kazuya, I. P., Miyamoto, D., Goto, H., Kawaoka, Y. and Suzuki, Y. & Suzuki, Y.** (2005). Sialidase activity of influenza A virus in an endocytic pathway enhances viral replication. *Journal of virology*, 79(18), 11705-11715.

**Tang, Y., Zaitseva, F., Lamb, R.A. & Pinto, L.H.** (2002). The gate of the influenza virus M2 proton channel is formed by a single tryptophan residue. *Journal of. Biology. Chem.* 277, 39880–39886.

**Tao, H., Li, L., White, M. C., Steel, J., & Lowen, A. C.** (2015). Influenza A virus co-infection through transmission can support high levels of reassortment. *Journal of virology*, JVI-01162.

**Tavaré, S.** (1986). Some probabilistic and statistical problems in the analysis of DNA sequences. *Lectures on mathematics in the life sciences*, 17(2), 57-86.

**Thierry, E., Guilligay, D., Kosinski, J., Bock, T., Gaudon, S., Round, A., ... & Hart, D. J.** (2016). Influenza polymerase can adopt an alternative configuration involving a radical repacking of PB2 domains. *Molecular cell*, 61(1), 125-137.

**Tong, S., Li, Y., Rivaller, P., Conrardy, C., Castillo, D. A., Chen, L. M., Recuenco, S., Ellison, J. A., Davis, C. T., York, I. A., Turmelle, A. S., Moran, D., Rogers, S., Shi, M., Tao, Y., Weil, M. R., Tang, K., Rowe, L. A., Sammons, S., Xu, X., Frace, M., Lindblade, K. A., Cox, N. J., Anderson, L. J., Rupprecht, C. E., & Donis, R. O.** (2012). A distinct lineage of influenza A virus from bats. *Proceedings of the National Academy of Sciences of the United States of America*, 109(11), 4269-4274

**Townzen, J. S.** (2008). Brower a. VZ, Judd DD, Entomology V. Identification of mosquito bloodmeals using mitochondrial cytochrome oxidase subunit I and cytochrome b gene sequences. *Medicine Veterinary Entomology*, 22, 386-393.

**Waiboci, L. W., Mott, J. A., Kikwai, G., Arunga, G., Xu, X., Mayieka, L., Emukule, G.O., Muthoka, P., Njenga, M.K., Fields, B.S. & Katz, M. A.** (2016). Which influenza vaccine formulation should be used in Kenya? A comparison of influenza isolates from Kenya to vaccine strains, 2007–2013. *Vaccine*, 34(23), 2593-2601.

**Wang, P., Song, W., Mok, B.W., Zhao, P., Qin, K., Lai, A., Smith, G.J., Zhang, J., Lin, T., Guan, Y., Chen, H.,** (2009), Nuclear factor 90 negatively regulates influenza virus replication by interacting with viral nucleoprotein. *Journal of Virology* 83, 7850-7861.

**Watanabe, T., Watanabe, S., Kawaoka, Y.** (2010), Cellular networks involved in the influenza virus life cycle. *Cell Host Microbe* 7, 427-439

**Wilson, I.A., Skehel, J.J., Wiley, D.C.,** 1981, Structure of the haemagglutinin membrane glycoprotein of influenza virus at 3 Å resolution. *Nature* 289, 366-373

**Wolfe, N. D., Dunavan, C. P., & Diamond, J.** (2007). Origins of major human infectious diseases. *Nature*, 447(7142), 279-283.

**World Health Organization.** (2015, December). Blueprint for R&D preparedness and response to public health emergencies due to highly infectious pathogens. *In Workshop on Prioritization of Pathogens.*

**Wright, P.F., Neumann, G., & Kawaoka, Y.** (2013). Orthomyxoviruses. *Fields virology*. 1186-1243.

**Yuan, P., Bartlam, M., Lou, Z., Chen, S., Zhou, J., He, X., Lv, Z., Ge, R., Li, X., Deng, T. Liu, Y.** (2009). Crystal structure of an avian influenza polymerase PAN reveals an endonuclease active site. *Nature*, 458(7240), 909-913. doi:10.1038/nature07720

## APPENDICES

### Appendix 1: Primers used for PCR reaction.

Primer name	Primer sequence
Forward	5'- ATGATGATGGGNATGTTYAAAYATG - 3'
Nested-Forward	5'- GATGGGNATGTTYAAAYATGYTDAGYAC - 3'
Reverse	5'- GCNCCNCCNAKDTCRYTRTTDATCAT - 3'

### Appendix 2: Primers used for Barcoding or RNA quality check.

Primer name	Primer sequence
CytB_Forward	5'- GAGGMCAAATATCATTCTGAGG- 3'
CytB_Reverse	5'- TAGGGCVAGGACTCCTCCTAGT- 3'

### Appendix 3: Reagent preparation

#### 1% Agarose

Weigh 2g of agarose and add it onto a 500ml flask then add 1x TBE slowly to the flask until the 200ml mark. Put to Microwave for 5 min making sure that the mixture does not boil over. Stop the microwave every 30s and spin the flask. Continue to heat until the agarose is completely dissolved and colorless, then add 2.5 µl of ethidium bromide to the dissolved agarose and mix.

#### Preparation of 1% TAE

Add 900mls of distilled water, then add 100mls of concentrated TBE buffer to make 1% the finally shake well the mixture before using.

**Appendix 4:** Cytochrome Oxidase 1 gene sequences of rodents and bats for DNA barcoding.

**Bat**

>180927-081\_C15\_COI KEAB. ab1 798

ACAGTTTCCGGATCTTGCTCATGAGGAGCTCTGTTGATTAACTATTTTCTCCCTA  
CACCTGGTGGTGTCTCATCCATTCTAGGTGCCATTAATTTTATTACTACTATCATT  
AATATAAAACCACCAGCCCTCTCACAATACCAAACACCCTTATTTGTATGATCTGT  
ATTAATTACAGCCGTACTACTCCTACGATCTCTACCGGTTTTAGCAGCAGGAATTA  
CAATACTACTAACAGATCGAAATTTAAACACCACCTTTTTTCGACCCTGCCGGAGG  
AGGAGATCCCATCCGATACCAACACCTATTCTGATTACTCTTCAGCCTGTTCCCTGC  
AACACCCTACCCATTCCGGGCGTCTCATCCATTCTAGGTGCCATTACTTTTATTAC  
TACTATCATTAAATATAAAACCACCAGCCCTCTCACAATACCAAACACCCTTATTTG  
TATGATCTGTATTAATTACAGCCGTACTACTCCTACTATCTCTACCGGTTTTAGCA  
GCAGGAATTACAATACTACTAACAGATCGAAATTTAAACACCACCTTTTTTCGACC  
CTGCCGGAGGAGGAGATCCCATCCTATACCAACACCTATTCTGATTAATCTTTACC  
ATGTTTTTGCACAATTCTCTGGTTCAAGGCTGGGCTATCAGAATATGTGTTGGTAT  
ACGATGGTATCTCCTCCTCCGCAGGGTCGAAAAGGTGGTGTAAATATCGTTCT  
TTCAACAGAAGTGCCATTCCGGCGCGAATACCGGTAAAGTAGTAGGATCGTCCGC  
CTGTACTTGAACAAATCA

>180927-081\_M19\_20\_COI\_short\_ KEAB.ab1 610

GCGTACATCGCTCGCAGTTGAAAAGGTGGTGTTTAAATTTTCGATCTGTTAGTAGT  
ATTGTAATTCCTGCTGCGAATACCGGGAGAGATAGTAGGAGTAGTACGGCTGTGT  
TAATACAGATCATAACGAATAAGGGTGTGGTATTGTTCGAGAGGGCTGGTGATTT  
TATATTAATGATAGTAGTAATAAAATTAATGGCACCTAGAATGGATGAGACACCT  
GCCAGGTGTAGGGAGAAAATAGTTAAATCAACAGAGGCTCCTGCATGAGCAAGA  
TTCCGGCTAAAGGAGGATAGACGGTTCAACCTGTTCCCTGCACCGGCTTCGATCA  
TATTACCAGCTTATATTCAGATTAAGAAGGAGGGAGGAGTCAGAAGCTTATGTT  
ATTTATTCGTGGGATAACTATATCAGGAGCGCCAATTATTAGTGGGACTAATCAG  
TTCCAAAGCCTCCGATCATAATGGGTATGACTATAAAGAAAATTATTACGAAAG  
CATGGGCGGTGACAATTACGTTGTAGATTTGATCGTCTCCAATAGAGCTCCAGG  
CTGGCCTAATTCAGCTCGAATAAGAAGACTTAGGGCGGTTTCATCCTGTTCCCTGCC  
CAAGTA

## Rodent

>180927-081\_G13\_13\_COI\_short KEAR.ab1 404

TCATCTAGCTGGTATCTAGCTCACGCTGGAGCATCAGTAGACCTAACAAATCTTCTC  
ACTCCATCTGGCTGGAGTATCTTCTATCCTAGGAGCCATTAAC TTTATCACGACCA  
TTATCAACATGAAACCCCCAGCCATAACCCAATATCAAACACCATTATTTGTTTG  
ATCTGTATTAATTACAGCTGTCCTCCTCTTGTTATCACTTCCAGTTCTAGCCGCAG  
GAATCACGATGCTACAAACAGACCGCAACCTAAATACAACATTCTTTGACCCTGC  
AGGAGGCGGAGACCCTATCCTATACCAACACCTATTCTGATTACCGTTCCTTTTTT  
TCTTCAAAAAAAAAATAATTTTTTTTTTTTTTAAAATAACACAAGCAGCAGCCGCAA  
GCGCGGAGACACGGG

**Appendix 5:** Kenyan human, baboons and bat partial PB1 nucleotide and amino acid sequences.

### Nucleotide sequence

>KEAB0224

TTAGTCAGAAGAGAAGATGATGCATCAGTGGCAGAAGATTACACCAGATCATCA  
TACTGGTGGGACGGACTCCAAC TCTCTGATGACTTTGCTCTCATAGTGAATGCAC  
CGAATCATGAGGGAATACAAGCAGGAGTAGACAGATTCTATAGAACCTGCAAGC  
TGGTCGGGATCAACATGAGCAAAAAGAAGTCCTACATAAACAGGACAGGAACA  
TTTGAATTCACAAGTTTTTTCTACCGCTACGGATTTGTAGCCAAC TTTAGCATGGA  
GTTGCCCAGTTTTTGGAGTGTCTGGGATTAATGAATCGGC

>KEAH0246

AGGGCAGAGAAGTACACCAAACAACATACTGGTGGGACGGACTCCAATCCTCT  
GATGACTTTGCTCTCATAGTGAATGTACCGAATCATGAGGGAATACAAGCAGGA  
GTAGACAGATTCTATAGAACCTGCAAGCTGGTCGGGATCAACATGAGCAAAAAG  
AAGTCCTACATAAACAGGACAGGAACATTTGAATTCACAAGTTTTTTCTACCGCT  
ACGGATTTGTAGCCAAC TTTAGCATGGAGTTGCCCAGTTTTTGGAGTGTCTGGGAT  
TAATGAATCGGCAGACATGAGCATTGGAGTGACAGTGATAAAAAACAACATGAT  
AAATACCGACATGG

>KEAP0313

ATGTTGAGCACAGTTTTTGGGAGTTTCGATTCTAAATCTAGGGCAGAAGAAGTAC  
ACCAAACAACATACTGGTGGGACGGACTCCAATCCTCTGATGACTTTGCTCTCA  
TAGTGAATGCACCGAATCATGAGGGAATACAAGCAGGAGTAGACAGATTCTATA  
GAACCTGCAAGCTGGTCGGGATCAACATGAGCAAAAAGAAGTCCTACATAACA  
GGACAGGAACATTTGAATTCACAAGTTTTTTCTACCGCTACGGATTTGTAGCCAA  
CTTTAGCATGGAGTTGCCCAGTTTTTGGAGTGTCTGGGATTAATGAATCGGCAGAC  
ATCACCTTG TTC

>KEAP0320

ATGTTTAGCACAGTTTTGGGAGTTTGGATTCTAAATCTAGGGCAGAAGAAGTACA  
CCAAAACAACATACTGGTGGGACGGACTCCAATCCTCTGATGACTTTGCTCTCAT  
AGTGAATGCACCGAATCATGAGGGAATACAAGCAGGAGTAGACAGATTCTATAG  
AACCTGCAAGCTGGTCGGGATCAACATGAGCAAAAAGAAGTCCTACATAAACAG  
GACAGGAACATTTGAATTCACAAGTTTTTTCTACCGCTACGGATTTGTAGCCAAC  
TTTAGCATGGAGTTGCCAGTTTTGGAGTGTCTGGGATTAATGAATCGGCAGACA  
TGAGCATTGGA

>KEAP0322

ATGTTGAGCACAGTTTTGGGAGTTTCGATTCTAAATCTAGGGCAGAAGAAGTAC  
ACAAAACAACATACTGGTGGGACGGACTCCAATCCTCTGATGACTTTGCTCTCA  
TAGTGAATGCACCGAATCATGAGGGAATACAAGCAGGAGTAGACAGATTCTATA  
GAACCTGCAAGCTGGTCGGGATCAACATGAGCAAAAAGAAGTCCTACATAAACA  
GGACAGGAACATTTGAATTCACAAGTTTTTTCTACCGCTACGGATTTGTAGCCAA  
CTTTAGCATGGAGTTGCCAGTTTTGGAGTGTCTGGGATTAATGAATCGGCAGAC  
ATCACCTTGTTT

>KEAP0326

ATGTTGAGCACAGTTTTGGGAGTTTCGATTCTAAATCTAGGGCAGAAGAAGTAC  
ACAAAACAACATACTGGTGGGACGGACTCCAATCCTCTGATGACTTTGCTCTCA  
TAGTGAATGCACCGAATCATGAGGGAATACAAGCAGGAGTAGACAGATTCTATA  
GAACCTGCAAGCTGGTCGGGATCAACATGAGCAAAAAGAAGTCCTACATAAACA  
GGACAGGAACATTTGAATTCACAAGTTTTTTCTACCGCTACGGATTTGTAGCCAA  
CTTTAGCATGGAGTTGCCAGTTTTGGAGTGTCTGGGATTAATGAATCGGCAGAC  
ATGAGCATTGGA

>KEAP0293

ATGTTGAGTACAGTTTTGGGAGTTTCGATTCTAAATCTAGGGCAGAAGAAGTACA  
CCAAAACAACATACTGGTGGGACGGACTCCAATCCTCTGATGACTTTGCTCTCAT  
AGTGAATGCACCGAATCATGAGGGAATACAAGCAGGAGTAGACAGATTCTATAG  
AACCTGCAAGCTGGTCGGGATCAACATGAGCAAAAAGAAGTCCTACATAAACAG  
GACAGGAACATTTGAATTCACAAGTTTTTTCTACCGCTACGGATTTGTAGCCAAC  
TTTAGCATGGAGTTGCCAGTTTTGGAGTGTCTGGGATTAATGAATCGGCAGACA  
TGAGCATTGGA



## Protein Sequences

>KEAH0246

RAEKYTKTTYWWDGLQSSDDFALIVNVPNHEGIQAGVDRFYRTCKLVGINMSKKKS  
YINRTGTFEFTSFFYRYGFVANFSMELPSFGVSGINESADMSIGVTVIKNNMINTDM

>KEAB0224

LVRREDDASVAEDYTRSSYWWDGLQLSDDFALIVNAPNHEGIQAGVDRFYRTCKLV  
GINMSKKKSYINRTGTFEFTSFFYRYGFVANFSMELPSFGVSGINES

>KEAP0313

MLSTVLGVSILNLGQKKYTKTTYWWDGLQSSDDFALIVNAPNHEGIQAGVDRFYRT  
CKLVGINMSKKKSYINRTGTFEFTSFFYRYGFVANFSMELPSFGVSGINESADITLF

>KEAP0320

MFSTVLGVWILNLGQKKYTKTTYWWDGLQSSDDFALIVNAPNHEGIQAGVDRFYR  
TCKLVGINMSKKKSYINRTGTFEFTSFFYRYGFVANFSMELPSFGVSGINESADMSIG

>KEAP0322

MLSTVLGVSILNLGQKKYTKTTYWWDGLQSSDDFALIVNAPNHEGIQAGVDRFYRT  
CKLVGINMSKKKSYINRTGTFEFTSFFYRYGFVANFSMELPSFGVSGINESADITLF

>KEAP0326

MLSTVLGVSILNLGQKKYTKTTYWWDGLQSSDDFALIVNAPNHEGIQAGVDRFYRT  
CKLVGINMSKKKSYINRTGTFEFTSFFYRYGFVANFSMELPSFGVSGINESADMSIG

>KEAP0293

MLSTVLGVSILNLGQKKYTKTTYWWDGLQSSDDFALIVNAPNHEGIQAGVDRFYRT  
CKLVGINMSKKKSYINRTGTFEFTSFFYRYGFVANFSMELPSFGVSGINESADMSIG

Appendix 6: Human Subject Approval



**KENYA MEDICAL RESEARCH INSTITUTE**

P.O. Box 54840-00200, NAIROBI, Kenya  
Tel: (254) (020) 2722541, 2713349, 0722-205901, 0733-400003, Fax: (254) (020) 2720030  
E-mail: [director@kemri.org](mailto:director@kemri.org), [info@kemri.org](mailto:info@kemri.org), Website: [www.kemri.org](http://www.kemri.org)

KEMRI/RES/7/3/1

April 28, 2017

TO: ALLAN OLE KWALLAH,  
PRINCIPAL INVESTIGATOR

THROUGH: THE DIRECTOR, CIPDCR,  
BUSIA

*Form grant  
gp  
A/RS/2017*

Dear Sir,

RE: KEMRI/SERU/CIPDCR/017/3445 (RESUBMISSION OF INITIAL SUBMISSION):  
SURVEILLANCE FOR EMERGING ZOOONOTIC DISEASE THREATS AND  
BEHAVIOURAL RISK CHARACTERISATION IN HIGH-RISK COMMUNITIES IN  
KENYA.

Reference is made to your letter dated April 21, 2017. The KEMRI Scientific and Ethics Review Unit (KEMRI/SERU) acknowledges receipt of the revised study documents on April 25, 2017.

This is to inform you that during the 261<sup>st</sup> Ethics Review Committee (ERC) held on March 21, 2017, the above referenced application was discussed.

This is to inform you that the Committee notes that the issues raised during the 261<sup>st</sup> of the Ethics Review Committee (ERC) held on March 21, 2017 have been adequately addressed.

Consequently, the study is granted approval for implementation effective this day **April 28, 2017** for a period of one year. Please note that authorization to conduct this study will automatically expire on **April 27, 2018**. If you plan to continue data collection or analysis beyond this date, please submit an application for continuation approval to SERU by **March 17, 2018**.

You are required to submit any proposed changes to this study to SERU for review and the changes should not be initiated until written approval from SERU is received. Please note that any unanticipated problems resulting from the implementation of this study should be brought to the attention of SERU and you should advise SERU when the study is completed or discontinued.

You may embark on the study.

Yours faithfully,

*for*   
**DR. EVANS AMUKOYE,**  
**ACTING HEAD,**  
**KEMRI SCIENTIFIC AND ETHICS REVIEW UNIT**

In Search of Better Health

Appendix 7: Animal use approval



Institute of Primate Research

Address: P.O. Box 24481-00502 Karen Nairobi Kenya | Tel: +254 02 2606235 | Fax: +254 02 2606231  
URL: www.primateresearch.org | Email: directoripr@primateresearch.org

P.O BOX 24481, KAREN, NAIROBI  
TELEPHONE 254-20-862571/4  
FAX: 254-20-892546  
E-Mail: [insecretary@primateresearch.org](mailto:insecretary@primateresearch.org)

INSTITUTIONAL SCIENTIFIC AND ETHICS REVIEW COMMITTEE  
(ISERC)  
FINAL PROPOSAL APPROVAL FORM

Our ref: IERC/08/16

Dear Dr. Joseph Kamau,

It is my pleasure to inform you that your proposal entitled "PREDICT/KENYA-KENYA WILDLIFE AND DOMESTIC CAMEL SERVEILLANCE FOR EMERGING PATHOGENS" in collaboration with Dr. Suzan Murray, Dr. Kall Holder, Dr. Dawn Zimmerman and Dr. Devin Tunsoth of the Smithsonian Institution, United States of America; Dr. Atunga Nyagio and Dr. Daniel Chai of IPR, Kenya has been reviewed by the Institutional Review Committee (IRC) at a meeting of 28<sup>th</sup> June 2016. The proposal was reviewed on the scientific merit and ethical considerations on the use of animals for research purposes. The committee is guided by the Institutional guidelines as well as international regulations, including those of WHO, NIH, PVEN and Helsinki Convention on the humane treatment of animals for scientific purposes and GLP.

You are bound by the IPR Intellectual Property Policy.

Signed Joseph Kamau Chairman IRC: DR. I. K. KARARA  
20/7/2016

SECRETARY Secretary IRC: DR. NGALLA JILANI  
INSTITUTE OF PRIMATE RESEARCH  
INSTITUTIONAL SCIENTIFIC AND ETHICS REVIEW COMMITTEE  
P. O. Box 24481-00502 KAREN NAIROBI  
NAIROBI, KENYA  
APPROVED .....