

***Assessment of Levels and  
“Health-Effects” of Airborne  
Particulate Matter in Mining, Metal  
Refining and Metal Working  
Industries Using Nuclear and  
Related Analytical Techniques***



**IAEA**

International Atomic Energy Agency

January 2008

IAEA-TECDOC-1576

***Assessment of Levels and  
“Health-Effects” of Airborne  
Particulate Matter in Mining, Metal  
Refining and Metal Working  
Industries Using Nuclear and  
Related Analytical Techniques***



**IAEA**

International Atomic Energy Agency

January 2008

The originating Section of this publication in the IAEA was:

Radiation and Transport Safety Section  
International Atomic Energy Agency  
Wagramer Strasse 5  
P.O. Box 100  
A-1400 Vienna, Austria

ASSESSMENT OF LEVELS AND "HEALTH-EFFECTS" OF AIRBORNE PARTICULATE  
MATTER IN MINING, METAL REFINING AND METAL WORKING INDUSTRIES USING  
NUCLEAR AND RELATED ANALYTICAL TECHNIQUES

IAEA, VIENNA, 2007  
IAEA-TECDOC-1576  
ISBN 978-92-0-110407-6  
ISSN 1011-4289

© IAEA, 2007

Printed by the IAEA in Austria  
January 2008

## FOREWORD

The International Atomic Energy Agency (IAEA) has been supporting, over the years, several coordinated research programmes (CRPs) on various research topics related to environmental issues impacting human health. The primary aim of these CRPs has been to help enhance the research and development capabilities in the Member States, particularly among developing countries; to identify the sources of various environmental contaminants and evaluate their fate; and to provide for the basis of improved health among human populations by the use of nuclear and related analytical techniques.

The CRP on Assessment of Levels and Health-Effects of Airborne Particulate Matter in Mining, Metal Refining and Metal Working Industries Using Nuclear and Related Analytical Techniques focused on improving the competence for research on workplace monitoring in a variety of industrial environments. The personal monitoring of the APM (airborne particulate matter) of the exposed workforce was carried out for the first time by many participants. Nuclear and related analytical techniques, including the application of proton micro-beam, were used to generate the trace element concentration profiles in various biomarkers tissues of the exposed workers. The quality assurance/quality control (QA/QC) aspects related to the CRP were addressed through intercomparison analyses of APM on filter paper samples and freeze dried human urine samples to generate validated data. These data have helped to generate correlations between the occupational exposure measured and the magnitude of the biological response. Such new information is essential to evolve procedures to considerably reduce/eliminate the pollutants in the workplace environment and to make informed decisions on the evolution of standards in working environments aimed at preserving the health of workers.

The purpose of this TECDOC is to provide an overview of the activities performed under the CRP by the participants. The overall achievements are summarized and those aspects that require a further deeper look are also pointed out. The individual country reports include details on the progress made by the respective participants during the CRP period. It is hoped that the results would encourage further research activities on these and related issues in the respective countries with the CRP participant as a catalyst to further these studies.

The IAEA wishes to thank all the participants in the CRP for their contributions. The IAEA officers responsible for the CRP were B. Smodiš and L. Davidsson of the Division of Human Health.

## *EDITORIAL NOTE*

*The papers in these proceedings are reproduced as submitted by the authors and have not undergone rigorous editorial review by the IAEA.*

*The views expressed do not necessarily reflect those of the IAEA, the governments of the nominating Member States or the nominating organizations.*

*The use of particular designations of countries or territories does not imply any judgement by the publisher, the IAEA, as to the legal status of such countries or territories, of their authorities and institutions or of the delimitation of their boundaries.*

*The mention of names of specific companies or products (whether or not indicated as registered) does not imply any intention to infringe proprietary rights, nor should it be construed as an endorsement or recommendation on the part of the IAEA.*

*The authors are responsible for having obtained the necessary permission for the IAEA to reproduce, translate or use material from sources already protected by copyrights.*

## CONTENTS

SUMMARY .....	1
Workplace and occupational health: The first metal evaluation using nuclear and analytical techniques in the state of Minas Gerais – Brazil .....	17
<i>M.Á. de B.C. Menezes, E.C.P. Maia, C. de V.S. Sabino, J.R. Batista, O.F. Neves, C. Albinati, S.S. Filho, S.V. de M. Mattos</i>	
A study on environmental pollution monitoring and occupational health in the capital iron and steel company, Beijing, China, using nuclear and related analytical techniques .....	41
<i>Zhifang Chai, Qinfang Qian, Xiangqian Feng, Peiquan Zhang, Nianqing Liu, Weiyu Feng, Minxu Kuang, Hongyu Wang, Yongzheng Zhang</i>	
Assessment of occupational exposure in manufacturing of stainless steel constructions using determination of selected metals in the workplace air and body tissues by neutron activation analysis and immunological tests.....	59
<i>J. Kučera, L. Borská, V. Bencko, J. Tejral, Z. Řanda, L. Soukal, V. Hnatowicz</i>	
Interlaboratory comparison survey of the determination of chromium, manganese, iron, titanium in welding dust and arsenic, cadmium, cobalt and chromium in urine....	79
<i>J.M. Christensen</i>	
Technical support for improved workplace monitoring solid aerosols with special attention to dust containing toxic trace elements .....	91
<i>E. Olsen, M.E. Nyeland, J.M. Christensen</i>	
Characterization of airborne Ce, Th and Cd in workplace and their co-relation with their concentrations in body fluids and excreta of occupational workers using NAA, ICP-AES and XRF .....	127
<i>P.M.B. Pillai, S. Radhakrishnan, C.G. Maniyan, P.P. Haridasan, B.S. Negi, M.G. Nair, P. Sawant, A. Kumar, N. Krishnan</i>	
The use of nuclear and related techniques for the studies of possible health impact of airborne particulate matter in a metal industry.....	143
<i>B. Widjajakusuma, H. Djojotubroto, A. Hidayat, D. Supriatna, E. Kumolowati</i>	
Monitoring of air particulate matter (APM), background radiation, analysis of trace metals and other parameters in some parts of Kenya .....	151
<i>A.M. Kinyua, C.K. Gatebe, M.J. Mangala, D.M. Maina, K. Korir, G.O. Odhiambo, S.K. Nderitu, P. Musyimi, J. Njogu, S. Bartilol, W.G. Mugeru, G.N. Kamau, N.O. Hashim, I.V.S. Rathore, R.L. Stangl, W. Njue, M.P. Oyugi, S.C. Chhabra, J.M. Chakaya, M. Karama, D.M. Miungu, R. Kwach, L.N. Njau, E.A. Mukolwe</i>	
Particulate matter and health — from air to human lungs .....	165
<i>T. Pinheiro, A. Bugalho de Almeida, P. Monteiro, E. Alvarez, D. Moniz, L.C. Alves, M.C. Freitas</i>	
Workplace monitoring and occupational health studies at the centre for production of phosphorus mineral fertilizers, Voskresensk (Moscow Region, Russian Federation), using nuclear and related analytical techniques .....	183
<i>S.M. Lyapunov, M.V. Frontasyeva</i>	
Workplace monitoring and occupational health studies in the Šoštanj thermal power plant, Slovenia .....	201
<i>R. Jačimović, A.B. Kobal, B. Stropnik, A. Sešek-Briški, I. Falnoga, Z. Jeran, M. Nečemer</i>	

Evaluation of the radiological impact of mineral products as a function of particle size distribution .....	215
<i>A. Faanhof, M. van Staden, I. Kungoane</i>	
Participants in the Coordinated Research Project .....	225

## SUMMARY

### 1. INTRODUCTION

The increased awareness of occupational health, hygiene and safety in recent years has resulted in improvement of working conditions and in reducing workers' exposure to many toxic substances. However, substantial hazards remain, the number of cases of occupational illness due to hazardous exposure is still high, and new cases will continue to occur if there are no further improvements. During the past years investigations have revealed a number of examples of unreported health problems related to occupational exposure. New problems have appeared with changes related to energy development, biotechnology, electronics, chemicals and other industrial activities. There is an increasing tendency to develop essentially ambient, but also biological limits and to develop methods of ensuring their implementation, thereby preventing health damage from exposure to toxic substances. Aspects of monitoring include providing information to help achieve compliance with standards, validating compliance and accumulating information for later revision of the standards.

Nuclear and related analytical techniques (NRATs) have important applications in the study of workplace monitoring associated with mining, refining and metal working industries, providing useful data in the assessment of possible negative health effects. Toxic heavy metals, together with trace elements that may have harmful effects, can be determined in airborne particulates and in human tissues by neutron activation analysis (NAA) using research nuclear reactors, by other modes of activation analysis (e.g. with photons), by particle induced X ray emission (PIXE) analysis, by nuclear microprobe techniques, by X ray fluorescence (XRF) analysis and by inductively coupled plasma-mass spectrometry (ICP-MS) analysis.

For many years the IAEA has been supporting coordinated research within the framework of a project on "Environmental pollution monitoring and research using nuclear and related analytical techniques". The objective of this work was to demonstrate the applicability of nuclear and related analytical techniques (mainly NAA, XRF, PIXE and ICP-MS) in studies of non-radioactive pollutants that may impact human health, with emphasis on problems that have been identified to be of high priority in national and international programmes for sustainable development. In view of the fact that the highest concentrations of toxic substances, in particular metals and their compounds, are generally observed in the workplace environment, the IAEA started in 1996 a Coordinated Research Project (CRP) on "Assessment of levels and health-effects of airborne particulate matter in mining, metal refining and metal working industries using nuclear and related analytical techniques".

A total of 11 countries, with participants from Africa, Asia, Europe and South America participated in the CRP. The CRP activities continued until December 2001. The first Research Coordination Meeting (RCM) was held in Vienna in October 1997. The second meeting was held in Belo Horizonte, Brazil, in May 1999, while the third and last meeting was hosted by the Government of Kenya in Nairobi, in March 2001. Several investigations were carried out beyond the final meeting and more detailed evaluations of the results obtained were performed after the CRP closure. These additional findings are included in individual country contributions as well as compiled in this summary.



### **1.1. Specific research objectives of the CRP**

The CRP focussed on the use of nuclear and related analytical techniques for studies of exposure to inorganic constituents and radionuclides from naturally occurring radioactive materials (NORMs), in the workplaces and their impacts on the health of the workers. The objectives were to:

- Develop strategies and techniques for sampling of workplace airborne particulate matter (APM) and of bio-markers (e.g. hair, blood, nails, teeth, urine, breath) of exposed and non-exposed individuals;
- Develop reliable analytical procedures for the analysis of such samples, using nuclear and related analytical techniques;
- Carry out workplace and personal monitoring surveys, and assess workers' exposure to toxic elements on the basis of measurements results.

### **1.2. Expected benefits of the CRP**

Overall, it was expected that the CRP would:

- Improve competence for research on workplace monitoring in terms of proper sampling and analytical procedures;
- Demonstrate the usefulness of NRATs in health related studies;
- Obtain new reliable data on sources and levels of workplace pollution in various countries;
- Contribute to a better data interpretation in the participating countries;
- Contribute to the systematic collection of data on possible toxic constituents;
- Provide a comparison of threshold limit values (TLVs) in the working environment allowed in the various participating countries and other international and national standards or regulations;
- Help develop procedures to reduce/eliminate the pollutants in the workplace environment;
- Encourage closer collaboration between analytical scientists and researchers in the field of occupational health.

### **1.3. Relationship to previous projects and related IAEA activities**

The CRP was built upon the experience gained during the global CRP on Applied Research on Air Pollution using Nuclear Related Analytical Techniques (1992–1997). The IAEA had already supported work in this field by (1) a CRP on Applied Research on Air Pollution using Nuclear Related Analytical Techniques in the Asia and Pacific Region (1995–1998), (2) Symposium on Harmonization of Health-Related Environmental Measurements Using Nuclear and Isotopic Techniques, held in Hyderabad, India, in November 1996.

## 2. RESULTS AND OUTCOMES OF THE CRP

### 2.1. Potential pollution sources and contaminants targeted

In each country participating in the CRP, workers in at least one facility related to mining, metal refining or metal working industries were selected as a study group. A variety of industrial environments such as: galvanisation, iron and steel production, steel construction, coal fired thermal power plants, mining and mineral beneficiation of monazite, zinc smelters, and phosphate fertilizer production plants were included in this CRP. Toxic elements specific for particular industries as potential pollutants were monitored within individual projects (e.g. Fe, Cr, Mn, Co, Ni, in steel production industries). However, given the fact that the majority of the participants used multi-element analytical techniques, they mostly analysed more elements that would be expected to be enriched in the samples collected.

### 2.2. Airborne particulate matter (APM) characterization

Workers in mining, metal refining and metal working industries are exposed to APM containing various levels of toxic elements with known neurotoxicity, genotoxicity, carcinogenic, allergenic and immunological effects. It is therefore important to obtain exposure data by direct measurements. Within the CRP, personal as well as stationary sampling was carried out and both total suspended matter (TSP) and size fractionated APM were collected. In personal sampling, the workers monitored were wearing portable samplers during their shifts. Such personal portable monitors consisted of filters connected with battery-operated pumps. Personal portable monitors made it possible to measure exposure directly for each individual. As stationary samplers, the “Gent” stacked filter units (SFUs) were employed having the PM<sub>10</sub> inlet and stacked cassette with two sequential polycarbonate filters with a pore size of 8 µm and 0.4 µm, respectively, operating at a flow rate of 16 L/min. Under these conditions, size fractionating of APM occurs so that the filters collect APM having equivalent aerodynamic diameters (EADs) of 2–10 µm (“coarse” fraction) and <2 µm (“fine” fraction), respectively. The participants used harmonised sampling protocols, adopted from one of the previous CRPs.

Throughout the CRP more than 2200 workplace APM samples were collected and analysed. Investigations carried out in galvanising and steel production/construction industries revealed elevated levels of specific metals in APM, often exceeding national or/and international admissible limits. In galvanising plants the most exposed workplace was the polishing area with Cr, Cu, Fe and Mn contents exceeding the threshold limit values (TLV) in most settings. In manufacturing stainless steel constructions, the highest contents of Cr, Mo and Mn were found in welders’ areas, with Cr exceeding the maximum admissible limit (MAL) values in most (69%) cases. Among polishers, Cr and Ni enrichment was the highest, often exceeding the MAL values (in 44% and 33% of samples, respectively). In workplaces dealing with drilling and assembling of vessels, MAL values were not exceeded.

In a zinc smelter plant producing zinc ingots and cadmium metal from zinc blend, Cd and Zn contents in APM exceeded TLV in some samples, with a mean Zn/Cd ratio of 344. At the initial process stages (milling and roasting) the fine fraction represented only about 4% of total APM while at down stream processes (electrolysis) the fine fraction represented about 50% of total APM. The results stress the importance of size fractionated APM sampling when assessing human exposure.

In a study carried out in two mineral separation and monazite processing plants in India, airborne thorium was investigated as inhalation is the most important route of occupational exposure. The  $^{232}\text{Th}$  activities in APM ranged from 0.001 to 0.066 Bq/m<sup>3</sup> and were thus lower than the derived air concentration (DAC) of 0.22 Bq/m<sup>3</sup> applicable to the mineral separation plants included in the CRP. The calculated corresponding annual equivalent dose was in the range of 1.0 to 2.0 mSv and thus well below the upper level of 20 mSv for occupational radiation exposure.

### **2.3. Interaction of metals with respiratory tissue**

Solubility of APM in body fluids is an important parameter to determine uptake of toxic elements by the human body. Therefore, in a separate study, APM samples were subjected to in vitro leaching experiment using lung serum simulant and assayed for Zn and Cd. The study revealed that less than 0.1% of Zn leached out in two hours. During the same time period nearly 2% of Cd became dissolved into the simulant. After 30 days exposure, about 0.5% of Zn and about 7% of Cd leached out. The enhanced solubility of Cd into the lung-serum simulant was attributed to better solubility of CdSO<sub>4</sub> compared with the solubility of ZnSO<sub>4</sub>.

In another study the morphology, the elemental distribution and mapping of the airway epithelium that allows for the characterization of inhaled APM, was assessed from biopsy material using nuclear microscopy techniques. The advanced analytical system used for this study allowed for deriving different kinds of sample images by using PIXE (Particle Induced X ray Emission) and RBS (Rutherford Backscattering Spectrometry) for element mapping, STIM (Scanning Transmission Ion Microscopy) for mass density variations or SEM (Secondary Electron Microscopy) for sample surface topography. In order to obtain element distribution maps, the sample area was scanned by a beam deflecting system and simultaneous PIXE, RBS and SEM analyses were performed. The results showed that the diffusion of elements from particles at distal regions of the respiratory system with a special emphasis to V, Cr and Ni appeared to be more important than at upper regions of the respiratory tree, where other elements such as Al, Si and Ti were predominant and associated with larger particles. The evidence obtained suggests high retention of specific elements in the respiratory system due to their chemical affinities to biological components or impaired phagocytosis due to their association with smaller particles.

### **2.4. Biological monitoring**

The results of direct physical monitoring may be misleading if various mechanisms related to intake and absorption lead to a different burden on the organism, if multiple mechanisms of intake are taking place, and especially if short- and long-term effects are to be distinguished. Therefore, the use of biological specimen in which the concentration of a pollutant is determined provides additional information on the levels of pollutants that already crossed the biological boundary and entered the human body. Blood, urine, hair, nails and toenails were used as target biological materials within the CRP. Altogether 617 hair and/or nail samples, 307 blood and/or blood component samples, 479 urine samples and approximately 100 other specimens (mostly teeth) were collected and analysed. Biological materials were sampled in conditions preventing external contamination. Urine was collected in plastic flasks on the first working day before starting a shift and the last work day of the week at the end of the shift. Blood was collected in pre-cleaned vials using Teflon canulas, following strict procedures aimed at preventing any extraneous contamination. Hair was collected and washed according

to the IAEA recommended protocol. Toenails were collected and washed according to the harmonised protocol agreed upon among the CRP participants.

It should be noted, however, that the levels found for trace elements in hair and nails should be interpreted cautiously as proof of occupational exposure. The reason is that any cleaning procedure aimed at removing exogenous contamination may influence the endogenous element content in a sample. Urinary and blood element levels could therefore be regarded as much more straightforward biological markers of occupational exposure. Depending on the element and its association with particular blood components, whole blood, serum and/or plasma should be chosen for analysis to obtain relevant information on recent and/or long-term exposure, or on element speciation. However, the concentrations of elements of interest in these body fluids are very low (e.g. Cr and Mn levels in urine are in the range of  $1\mu\text{g/L}$ ) and highly sensitive analytical techniques should be used for their determination. In addition, the procedure involved should prevent any sample contamination during sample treatment. Radiochemical neutron activation analysis (RNAA) is one of the techniques of choice for the contamination-free determination of these elements at very low concentration ranges.

In the galvanising plants, hair, toenail and urine samples were collected from the exposed and control groups. Statistical tests applied (Pearson correlation, principal component analysis, ANOVA and t-test) to the element set obtained for hair samples revealed statistically significant differences among different types of workers (polishers, platters, cleaners) as well as correlations with the length of time working at a specific activity. By including toenail samples, it was possible to differentiate between the two plants investigated in Brazil. In all cases there was a significant difference between the exposed and control groups with Cr as the most significant element. However, the TLV for chromium in urine ( $30\mu\text{g/g}$  creatinine) was never exceeded.

The iron concentrations in human serum of workers from Capital Iron and Steel Company (CISC), Beijing, China, exceeded literature data for the world by a factor of 6–7. The levels of Cr, Cd, Co, Cu, Ni, Pb and Zn were also higher compared to the literature data. A similar pattern was found for urine samples. Statistical analysis of data sets obtained for hair samples showed significant differences in exposed and control groups for Fe, Co, Cr and Zn. In a plant manufacturing stainless steel in the Czech Republic, significantly increased ( $p<0.001$ ) levels of Cr in hair and nails and significantly increased ( $0.01<p<0.001$ ) levels of Mo in hair were found in the exposed group. Urinary Cr was significantly increased ( $p<0.001$ ) in the exposed group compared to controls revealing that urinary Cr appears to be a suitable indicator for monitoring of occupational exposure to Cr. In this particular study, the relationship between the results of direct exposure monitoring as measured by personal samplers (TSP) and those of biological monitoring was examined in order to assess the relevance of both types of monitoring for individuals. The exposure data for Cr, Mo, Mn and V were assessed by applying the Spearman rank correlation coefficient; no significant correlations ( $p>0.05$ ) were found. This fact was attributed to (1) the sampling campaign that provided data only for acute exposure due to its time limitation and (2) the type of APM collector used that did not provide representative data for elements entering the respiratory tract, but only for TSP. These results suggest that the use of inexpensive simple personal monitors, collecting only TSP, may result in erroneous estimation of dose based on direct exposure measurements.

The study carried out in mineral separation and monazite processing plants located at natural radioactivity high background area (NHBA) showed that the important parameters in applying metabolic models are: inhalation exposure to airborne radioactive mineral dust,

differences in the physico-chemical form of the intake, the subsequent translocation from the lungs and the natural environmental contribution (particularly at NHBA). Those parameters are particularly important in interpreting other results based on urine analysis or exhaled thoron measurements for internal dose evaluation. Inhaled mineral dust tend to remain in the lungs for longer periods of time as it is insoluble, contributing to higher lung burden and lower urinary thorium concentrations in mineral separation plant workers. In workers engaged in chemical processing of monazite, the inhaled particles are more soluble resulting in faster elimination from the lungs (reduced lung burden) and enhanced urinary Th concentrations. On the other hand, the observed urinary excretion rate for populations living in the NHBA is more than four times higher than ICRP's (International Commission on Radiological Protection) model for inhaled Th. This observation is attributed to additional modes of Th intake (i.e. by water and food consumption) by the local population.

## **2.5. Medical health examinations and biological markers**

Medical doctors were team members in all the participating countries in order to better assess potential impact of workplace pollutants on human health, although the Chief Scientific Investigators were mostly analytical specialists. Health examinations were carried out according to the practices used in each country and specificities of the workplaces concerned. The examination usually comprised medical history, physical examination, routine blood analysis and pulmonary function tests. Throughout the CRP more than 2600 subjects were examined including 290 control subjects.

At the CISC, Beijing, China, the results of workers' health status showed that exposed individuals suffered clinical symptoms such as high blood pressure, hypoglycaemia, pharynx irritation, pharynx itching and abnormal mucus with higher probability than the control group. However, none of these symptoms could be statistically linked to a specific pollutant. Similar non-conclusive findings were observed in metal industry in Indonesia, where no symptoms related to metal toxicity were found. In a coal-fired power plant in Slovenia, where health effects of welders' long term exposure to dust were surveyed, no important damage or effects on respiratory functions were found. Also no effects on tubular functions, surveyed by measurements of urinary N-acetyl-beta-D-glucosaminidase (NAG) constituents, were identified.

Medical examinations performed on workers exposed to metal airborne particles in a steel processing plant in Portugal included medical history, lung function tests, thoracic radiography, as well as chest radiography for diagnosing airway limitations in exposed workers. Marked respiratory problems (lung function alterations and radiographic opacities) were detected in 24% and significant opacities in the X ray examinations were observed in 25% in staff, working for more than 15 years at the steel processing plant.

The most detailed study was carried out on a group working in the plant manufacturing stainless steel constructions in the Czech Republic, where additional examinations included also haematological, genotoxicity and immunological assays. Of the haematological parameters examined, such as leucocytes, erythrocytes, haemoglobin, haematocrit, neutrophils, eosinophils, basophils, lymphocytes, monocytes, thrombocytes and rods, only the number of rods was significantly increased ( $0.05 < p < 0.01$ ) in the exposed workers compared to controls. No significant differences were found between the numbers of all types of aberrated cells in both groups.

The first barrier against xenobiotic substances is the body surface. If this is penetrated, then the agents come into contact with components of the immune system. Therefore, a number of immunological tests were carried out on the groups studied. The phagocytosis activity was tested using yeast ingestion. The enzyme linked immunosorbent assay (ELISA) method was employed for the determination of levels of serum neopterin and  $\beta$ -2-microglobulin. To monitor the mucous membrane response, saliva was assayed for lysozyme and secretory immunoglobulin A (IgA). An ELISA method was also employed for the determination of levels of serum interleukin IL-1- $\beta$  and total immunoglobulin E (IgE) as markers of hypersensitivity. No significant increase of both lysozyme and IgA was found. Marginally significant increase of IgE ( $p=0.046$ ) in the exposed group may be a result of sensitisation by the exposure. Among the indicators of the burden of cellular immune system, neopterin ( $p<0.01$ ) and IL-1- $\beta$  ( $p=0.004$ ) levels were significantly increased in the exposed workers compared to the control group. Also the C3 constituent of complement was significantly increased ( $p<0.01$ ). A highly significant decrease of immunoglobulin M (IgM) was contributed to the immune-suppressive effect of welding fumes. Also a significant increase of the c-reactive protein, an indicator of inflammation, was observed in the exposed workers. Upon comparing results of direct monitoring and biological markers, no conclusive associations and trends between exposure and the response of immune parameters could be revealed. It is known that the response of immunological parameters to various xenobiotic substances is not specific. Thus, in case of multiple sources of exposure, it is impossible to distinguish, both in qualitative and quantitative ways, which individual source contributes to the alteration of the immune parameters. Indeed, within the study sites also non-negligible levels (460–880 ng/m<sup>3</sup>) of polycyclic aromatic hydrocarbons (PAHs) were determined, that might interfered with the data. Nevertheless, it is important to include an integral assessment of general health status, exemplified by altered immune parameters, for taking appropriate countermeasures aimed at minimizing health risk due to overall occupational exposure.

## **2.6. External analytical quality assessment**

Two interlaboratory comparison (IC) exercises were organized based on the Danish External Quality Assessment Scheme. The first one was held in the year 1998, on the determination of trace elements in urine and welding dust collected on filters (Cr, Mn, Fe, Ti) and the second one in the year 2000, on trace elements in freeze-dried urine (As, Cd, Co and Cr). The urine samples in each round had three different concentrations of each element. The results of the first IC revealed that several laboratories might have contamination or calibration errors for As, Cd and Cr because all of the obtained results at the three concentration levels showed a linear functional relationship. In the second IC the analytical performance had improved compared to the first one.

## **3. CONCLUSIONS AND RECOMMENDATIONS**

The completed CRP produced data that supplement already existing information and contribute to better understanding of workplace APM levels and their health effects. Improved strategy and technology of APM sampling was implemented and the applicability of NRATs for analysis of biological matrices was demonstrated. The importance of radiochemical neutron activation analysis in determining ultra traces of some toxic elements in body tissues and fluids was confirmed. The performance of the nuclear and related analytical techniques used in the CRP was significantly improved as shown by the IC results, and a PC software programme (AMIQAS) for integrated quality control, method evaluation

and proficiency testing was introduced and delivered to the participants to be used in the future, as a useful tool to validate analytical methods and to establish and maintain routine quality control procedures. Good contacts between analysts using NRATs with various industries, and most importantly with the medical community were established. The medical community was made aware of the need of contamination-free sampling and sample handling for determination of metals and other elements in biological materials at trace and ultra trace levels. Several research teams made available proper sampling technology to their medical counterparts for future use. New knowledge was obtained on correlations between the occupational exposure and the magnitude of biological response. Research using nuclear microprobe techniques revealed possibilities to study the health effects of occupational exposure at the cellular level. The knowledge obtained on occupational exposures and the related health effects supports National Authorities in participating countries to formulate codes and regulations to control occupational exposures in the industries concerned. This has already been demonstrated in one participating country. The results obtained were published in IAEA reports, conference proceedings, and papers in refereed journals. One review paper on strategies and techniques for APM monitoring, included in this TECDOC, was developed for possible future training of personnel. One participant used the national contribution to this CRP for a Ph.D. thesis.

The association between trace element concentrations and associated health hazards could not be established unequivocally, in all sites. Thus, other parameters of multiple exposures should be included for data interpretation in these studies. It is of foremost importance to clarify the interaction between the environment and the individual exposed. The variety of parameters included (APM size and elemental composition, elemental levels in body fluids and tissues) has enabled us to gain better knowledge of the influence of the workplace environment on the exposure levels of trace elements in the workers. However, it is necessary to obtain further data on:

- The dispersion of pollutants in the workplace;
- The chemical (species) composition of APM;
- The organic components of APM.

The residence time of the inhaled APM in the organism, the transport from the lungs and elimination from the body are important issues to be addressed to better understand the interactions between xenobiotics and the human body. For biological monitoring to assess exposure, extended studies aimed at evaluating the physiological status of exposed subjects would be required. Both element determinations and biochemical indicators in body fluids should be included in future studies to better assess the response of biological systems exposed to APM. New approaches for data interpretation to integrate the parameters and their possible synergistic effects on biological system should be explored to better assess the exposure to toxic substances.

#### 4. WORK DONE SINCE THE CLOSURE OF CRP

Data generated within the project were further explored and used in strengthened contributions to further developments in the concerned scientific field:

- Participants from Russian Federation and Denmark collaborated in the 5<sup>th</sup> Framework Program of the European Commission, in a Copernicus project “Fertilisers and health”, during the years 2000–2002. The project was concerned with workplace monitoring and occupational health studies at some selected phosphate fertiliser plants.
- Research groups from China, Czech Republic, Denmark and Slovenia continue their research work within the framework of the 6<sup>th</sup> Framework Program of the European Commission, in a project PHIME — “Public health impact of long-term, low-level mixed element exposure in susceptible population strata”. The project, which is expected to be active until 2011 comprises altogether 31 partners from 20 countries.
- Participants from India and South Africa presented their new scientific achievements at 5<sup>th</sup> International Symposium on “Naturally Occurring Radioactive Material” held in March 2007. Their work, concerned with mineral processing activities, was based on data generated within the CRP.
- The groups from Russian Federation and Slovenia build from their experience and results emerged throughout the CRP in preparing a new project proposal for the 7<sup>th</sup> Framework Program of the European Commission. The proposal is addressing long-term pollution monitoring, evaluation of health effects of the selected pollutants monitored and knowledge transfer of epidemiological studies based also on data generated within this CRP.

The above mentioned continuous activities emphasize the relevance of data and knowledge generated within the CRP. The recently issued 7<sup>th</sup> Framework Program includes as one of its important goals further research into health effects of exposure to environmental stressors. The expected impacts include new pollutant concentration data, harmonised models and sampling approaches, improved risk assessment and toxicological data, and coordinated approach to human biomonitoring. Given the fact that the CRP participants actively contribute to these activities reconfirms the still present importance and relevance of the data generated within the project.

Based on the large number of studies carried out within the framework of this CRP and beyond, a number of publications emerged. A list of these publications is provided below for the readers who would like to obtain a deeper insight into the particular parts of the work carried out throughout the CRP.

#### 5. PUBLICATIONS AND PRESENTATIONS ARISING OUT OF THE CRP

MENEZES, M.Â.B.C., MAIA, E.C.P., ALBINATI, C.C.B., AMARAL, Â.M., Assessment of gold exposure and contamination in galvanizing workplace by neutron activation analysis, *J. Radioanal. Nucl. Chem.* **271**(1) (2007) 119–123.

ZHANG, Z.Y., CHEN, C.Y., FENG, W.Y., CHAI, Z.F., Isotopic Tracer Studies on the Metabolism and Functional Roles of Mineral Elements in Institute of High Energy Physics, China, *J. Nucl. Sci. Technol.* **43** (2006) 1–5.



CHEN, C.Y., YU, H.W., ZHAO, J.J., LI, B., QU, et al., The Roles of Serum Selenium and Selenoproteins on Mercury Toxicity in Environmental and Occupational exposure, *Environ. Health Perspect.* **114** (2006) 297–301.

ZHANG, Z.Y., CHEN, C.Y., FENG, W.Y., CHAI, Z.F., Isotopic tracer studies on the metabolism and functional roles of mineral elements in IHEP, China, *J. Nucl. Sci. Technol.* **43** (2006) 450–454.

FENG, L.X., XIAO, H.Q., HE, X., LI, Z.J., LI, F.L., et al., Neurotoxicological consequence of long-term exposure to lanthanum, *Toxicol. Letters* **165** (2006) 112–120.

SZCZEPANIAK, K., SARBU, C., ASTEL, A., RAINSKA, E., BUZIUK, M., et al., Assessment of the impact of a phosphatic fertilizer plant on the adjacent environment using fuzzy logic, *Central European Journal of Chemistry* **4**(1) (2006) 29–55.

KOBAL GRUM, D., KOBAL, A.B., ARNERIĆ, N., HORVAT, M., ŽENKO, B., et al., Personality Traits in Miners with Past Occupational Elemental Mercury Exposure, *Environ. health perspect.* **114**(1) (2006).

FALNOGA, I., TUŠEK-ŽNIDARIČ, M., STEGNAR, P., The influence of long-term mercury exposure on selenium availability in tissues: an evaluation of data, *Biometals* **19** (2006) 283–294.

TUŠEK-ŽNIDARIČ, M., PUCER, A., FATUR, T., FILIPIČ, M., ŠČANČAR, J., et al., Metal binding of metallothioneins in human astrocytomas, *Biometals* **19** (2006) 1–12.

CHEN, C.Y., QU, L.Y., LI, B., XING, L., JIA, G., et al., Increased oxidative DNA damage, as assessed by urinary 8-hydroxy-2'-deoxyguanosine concentrations, and serum redox status in persons exposed to mercury, *Clin Chem.* **51** (2005) 759–767.

RAINSKA, E., BUZIUK, M., SARBU, C., SZCZEPANIAK, K., FRONTASYEVA, M.V., et al., Assessment of phosphatic fertilizer production impact on occupational staff based on NAA of hair, nails, and inhaled particles, *Journal of Environmental Science and Health, Part A* **40** (2005) 2137–2152.

GRÖNLUND, R., EDNER, H., SVANBERG, S., KOTNIK, J., HORVAT, M., Mercury emissions from the Idrija mercury mine measured by differential absorption lidar techniques and a point monitoring absorption spectrometer, *Atmos. environ.* **39** (2005) 4067–4074.

OSREDKAR, J., ŽENKO, B., KOBAL GRUM, D., KRSNIK, M., DŽEROSKI, S., et al., Analysis of the relationship between pineal hormone melatonin level and occupational mercury exposure in ex-miners with machine learning methods, *Metodol. zv.* **1** (2005) 161–172.

MARN-PERNAT, A., BUTUROVIĆ-PONIKVAR, J., LOGAR, M., HORVAT, M., PONIKVAR, R., Increased ethyl mercury load in protein a immunoadsorption, *Therap. apher. dial.* **3** (2005) 254–257.

HORVAT, M., GIBIČAR, D., Speciation of mercury: Environment, food, clinical, and occupational health. In: CORNELIS, R. (ed.). Handbook of elemental speciation II: species in the environment, food, medicine & occupational health. New York; Chichester: Wiley (2005) 281–304.

CHAI, Z.F., QIAN, Q.F., FENG; X.Q., ZHANG, P.Q., LIU, N.Q., et al., Study of occupational health impact of atmospheric pollution on exposed workers at an iron and steel complex by using neutron activation analysis of scalp hair, J Radioanal Nucl Chem. **259** (2004) 153–156.

CHEN, C.Y., ZHAO, J.J., YU, H.W., ZHANG, P.Q., LI, B., et al., Study on the roles of serum selenoproteins upon Hg toxicity in chronic mercury mine workers, Materials & Geoenviron. **51** (2004) 373–376.

CHEN, C.Y., ZHANG, P.Q., CHAI, Z.F., Distribution patterns of some heavy metals in subcellular fractions of human liver specimens, Chinese Science Bulletin **49** (2004) 2049–2051.

KUČERA, J., BENCKO, V., TEJRAL, J., BORSKA, L., SOUKAL, L., et al., Biomonitoring of occupational exposure. Neutron activation determination of selected metals in the body tissues and fluids of workers manufacturing stainless steel vessels, J. Radioanal. Nucl. Chem. **259** (2004) 7–11.

MENEZES, M.Â.B.C., SABINO, C.V.S., FRANCO, M.B., MAIA, E.C.P., ALBINATI, C.C.B., Assessment of workers'contamination caused by air pollution exposure in industry using biomonitors, J. Atmospheric Chem. **49**(3) (2004) 403–414.

MENEZES, M.Â.B.C., MAIA, E.C.P., ALBINATI, C.C.B., SABINO, C.V.S., BATISTA, J.R., How suitable are scalp hair toenail as biomonitors, J. Radioanal. Nucl. Chem. **259**(1) (2004) 81–86.

JAĆIMOVIĆ, R., HORVAT, M., Determination of total mercury in environmental and biological samples using k<sub>0</sub>-INAA, RNAA and CVAAS/AFS techniques : advantages and disadvantages, J. radioanal. nucl. chem. **259** (2004) 385–390.

KOBAL, A.B., HORVAT, M., PREZELJ, M., SEŠEK-BRIŠKI, A., KRSNIK, et al., The impact of long-term past exposure to elemental mercury on antioxidative capacity and lipid peroxidation in mercury miners, J. trace elem. med. biol. **17** (2004) 261–274.

KOBAL GRUM, D., ARNERIĆ, N., KOBAL, A.B., HORVAT, M., ŽENKO, et al., Can occupational exposure to elementary mercury increased the risk of suicide? In: HORVAT, M. (ed.), OGRINC, N. (ed.), FAGANELI, J. (ed.), KOTNIK, J. (ed.). Mercury as a global pollutant (RMZ - Materials and geoenvironment **51**(1-3) (2004) 452–457, Ljubljana: Naravoslovnotehniška fakulteta: Inštitut za rudarstvo, geotehnologijo in okolje.

KOBAL GRUM, D., ARNERIĆ, N., KOBAL, A.B., HORVAT, M., ŽENKO, et al., Emotions and personality traits in former mercury miners, Psihol. obz. (Ljubl.) **4** (2004) 9–31.

KOBAL, A.B., SEŠEK-BRIŠKI, A., KRSNIK, M., HORVAT, M., DIZDAREVIČ, T., et al., Potential kidney effects in ex-mines of the Idrija mercury mine exposed to elemental mercury and silica dust. In: HORVAT, M. (ed.), OGRINC, N. (ed.), FAGANELI, J. (ed.), KOTNIK, J. (ed.), Mercury as a global pollutant, RMZ - Materials and geoenvironment **51**(1-3) (2004) 447–451, Ljubljana: Naravoslovnotehniška fakulteta: Inštitut za rudarstvo, geotehnologijo in okolje.

LOGAR, M., HORVAT, M., HORVAT, N., BENEDIK, M., MARN-PERNAT, A., PONIKVAR, R., OSREDKAR, J., Determination of ethyl mercury and methyl mercury in blood samples, In: HORVAT, M. (ed.), OGRINC, N. (ed.), FAGANELI, J. (ed.), KOTNIK, J. (ed.), Mercury as a global pollutant, RMZ — Materials and geoenvironment **51**(1-3) (2004) 1967–1978, Ljubljana: Naravoslovnotehniška fakulteta: Inštitut za rudarstvo, geotehnologijo in okolje.

MARN-PERNAT, A., LOGAR, M., HORVAT, M., PONIKVAR, R. Increased mercury load in protein A immunoabsorption, In: HORVAT, M. (ed.), OGRINC, N. (ed.), FAGANELI, J. (ed.), KOTNIK, J. (ed.), Mercury as a global pollutant, RMZ — Materials and geoenvironment **51**(1-3) (2004) 1979, Ljubljana: Naravoslovnotehniška fakulteta: Inštitut za rudarstvo, geotehnologijo in okolje.

KOBAL, A.B., ŽENKO, B., KOBAL GRUM, D., KRSNIK, M., DŽEROSKI, S., et al., Analysis of excretion of pineal gland hormone melatonin in ex-mercury miners with learning methods. In: STARE, J. (ed.), VIDMAR, G. (ed.), KOREN, G. (ed.). International Conference Applied Statistics, Ljubljana, Slovenia, September 19–22, 2004. Program and abstracts. Ljubljana: Statistical Society of Slovenia, 2004, p. 32–36.

ŽENKO, B., DŽEROSKI, S., KOBAL, A.B., KOBAL GRUM, D., ARNERIČ, N., et al., Relating personality traits and mercury exposure in miners with machine learning methods: a preliminary study. In: SH@RING: proceedings of the 18th International Conference Informatics for Environmental Protection, October 21–23, 2004, CERN, Geneva (Switzerland): EnviroInfo Geneva 2004. Geneve: Editions du Tricorne, 2004, p. 400–412.

MENEZES, M.Â.B.C., SABINO, C.V.S., FRANCO, M.B., KASTNER, G.F., MONTOYA, E.H.R.,  $k_0$ -Instrumental Neutron Activation analysis establishment at CDTN, Brazil: a successful story, J. Radioanal. Nucl. Chem. **257**(3) (2003) 627–632.

MAZEJ, D., FALNOGA, I., STIBILJ, V., Selenium determination in whole blood, plasma and selenoprotein P by hydride generation atomic fluorescence spectrometry, Acta chim. slov. **50** (2003) 185–98.

STIBILJ, V., MAZEJ, D., FALNOGA, I., A study of low level selenium determination by hydride generation atomic fluorescence spectrometry in water soluble protein and peptide fractions, Anal. bioanal. chem. **377** (2003) 1175–1183.

MENEZES, M.Â.B.C., Assessment of exposure and contamination in galvanising workplace using airborne particulate filters and biomonitors (in Portuguese), Doctor Thesis: Instituto de Ciências Exatas — Departamento de Química — Universidade Federal de Minas Gerais/UFMG (Institute for Exact Sciences — Department of Chemistry — Federal University of Minas Gerais). Area: Inorganic Chemistry (2002).

MENEZES, M.Â.B.C.; MAIA, E.C.P., ALBINATI, C.C.B., Instrumental neutron activation analysis as an analytical tool on supporting the establishment of guidelines and data basis for worker's health awareness program, *Revista Brasileira de Pesquisa e Desenvolvimento* **4**(3) (2002) 1110–1117.

MENEZES, M.Â.B.C., MAIA, E.C.P., S FILHO, S., ALBINATI, C.C.B., Assessment of occupational exposure and contamination by means of airborne particulate matter and biomonitors using  $k_0$ -INAA, *J. Radioanal. Nucl. Chem.* **254** (2002).

FALNOGA, I., KOBAL, A. B., STIBILJ, V., HORVAT, M., Selenoprotein P in subjects exposed to mercury and other stress situations such as physical load or metal chelation treatment, *Biol. trace elem. res.* **89** (2002) 25–33.

FATUR, T., TUŠEK-ŽNIDARIČ, M., FALNOGA, I., ŠCANČAR, J., LAH TURNŠEK, T., et al., DNA damage and metallothionein synthesis in human hepatoma cells (HepG2) exposed to cadmium. *Food chem. toxicol.* **8** (2002) 1069–1076.

GORBUNOV, A.V., GOLUBCHIKOV, V.V., LYAPUNOV, S.M., ONISCHENKO, T.L., OKINA, et al., Impact of nitrogen-phosphate mineral fertilizer on the environment and man, *Environmental Chemistry*, **10**(4) (2001) 255–268 (in Russian).

HORVAT, M., LIYA, Q., JEREB, V., LOGAR, M., NOLDE, N., et al., Impact of mercury mining in the environment and human health, In: *Proceedings of NIMD forum 2001: mercury research: today and tomorrow*, March 19–29, 2001, National Institute for Minamata Disease (2001) 12–26.

KOBAL, A.B., ARNERIĆ, N., KOBAL GRUM, D., OSREDKAR, J., HORVAT, M., Impact of past elemental mercury occupational exposure on personality traits, and melatonin level in blood and urine, In: HINES, M. E. (ed.), HORVAT, M. (ed.), FAGANELI, J. (ed.), *Workshop on mercury in the Idria region and the Northern Adriatic Portorož 2001*, *RMZ — Materials and geoenvironment*, Ljubljana: Naravoslovnotehniška fakulteta **48**(1) (2001) 132–137.

BARREIROS, M.A., PINHEIRO, T., ARAÚJO, M.F., COSTA, M.M., PALHA, M., et al., Quality assurance of X ray spectrometry for chemical analysis, *Spectrochim. Acta B* **56**(11) (2001) 2095–2106.

CHRISTENSEN, J.M., BYRIALSEN, K., Proficiency testing in occupational and environmental health — current practice and international initiatives for harmonisation, *Accred. Qual. Assur.* **6**(4&5) (2001) 207–210.

KUČERA, J., BENCKO, V., PÁPAYOVÁ, A., ŠALIGOVÁ, D., TEJRAL, J., et al., Monitoring of occupational exposure in manufacturing of stainless steel constructions, Part I: Chromium, manganese, molybdenum, nickel and vanadium in the workplace air of stainless steel welders, *Central Eur. J. Public Health* **9**(4) (2001) 171–175.

PILLAI, P.M.B., MANIYAN, C.G., RADHAKRISHNAN, S., NAIR, M.G., KHAN, A.H., Thorium in urine and thoron in exhaled breath as indicators of internal exposures in monazite and thorium processing, *Rad. Prot. Environ.* **24**(1&2) (2001) 105–108.

PINHEIRO, T., ALVES, L.C., PALHANO, M.J., BUGALHO DE ALMEIDA, A., Mobilisation of toxic elements in the human respiratory system, *Nucl. Instr. Meth. B*, **181**(1) (2001) (499–505).

BARREIROS, M.A., PINHEIRO, T., ARAÚJO, M.F., COSTA, M.M., PALHA, M., et al., Quality Assurance in Nuclear Related Analytical Techniques, Proceedings of the European Conference on Analytical Chemistry EUROANALYSIS XI, Lisbon, Portugal, 3–9 September, 2000.

BORSKÁ, L., ANDRÝS, C., FIALA, Z., TEJRAL, J., BENCKO, et al., Immunological profile of men with occupational exposure to emissions from welding of stainless steel, *Prac. Léč.* **52** (2000) 63–68 (in Czech).

GITARI, W.M., KINYUA, A.M., KAMAU, G.N., GATEBE, C.K., Elemental Composition of Fine and Coarse Suspended Particulate Matter (SPM) and Acute Respiratory Infection (ARI) Monitoring in Kibera, Nairobi, Kenya, Proceedings of 5<sup>th</sup> Kenya Meteorological Society Workshop, Mombasa, Kenya, 4–8 September 2000.

PILLAI, P.M.B., Monitoring of Zn and Cd Aerosols in a Zinc Ore Processing Plant in relation to Occupational Exposures, Proc. of the Conference on Aerosol behaviour in Confined Environments, February 2000, Mumbai, IASTA Bulletin, Special Issue **13**(1) (2000).

PINHEIRO, T., Nuclear Techniques for Toxicology and Environmental Health Studies, Proceedings of the NATO Advanced Research Workshop on Monitoring of Natural and Man-made Radionuclides and Heavy Metal Waste in Environment, Dubna, Russian Federation, 3–6 October 2000.

LOPES, C., Application of Nuclear Microscopy Techniques in Biomedicine - Interaction of Inhaled Particles with the Human Respiratory Tissue, (original title: Aplicações de técnicas de microscopia nuclear em Biomedicina — interação de poeiras respiráveis no aparelho respiratório humano), Biophysics Project, Graduation in Physics, Faculty of Sciences, Lisbon University, Portugal (2000) (in Portuguese).

MENEZES, M.Â.B.C., SABINO, C.V.S., AMARAL, A.M., MATTOS, S.V.M., FILHO, S.B.S.,  $K_0$ -NAA applied to certified reference materials and hair samples: evaluation of exposure level in a galvanising industry, *J. Radioanal. Nucl. Chem.*, **245**(1) (2000) 173–178.

MENEZES, M.Â.B.C., MAIA, E.C.P., NEVES, O.F., BATISTA, J.R.,  $K_0$  — Ativação Neutrônica Paramétrica: Avaliação da Contaminação em Trabalhadores Utilizando o Biomonitor Cabelo, Encontro de Aplicações Nucleares, V, 15–20 outubro de 2000, Rio de Janeiro, Anais, Rio de Janeiro, ABEN (2000) (CD-ROM).

BUGALHO DE ALMEIDA, A., PINHEIRO, T., MONTEIRO, P., ALVAREZ, E., MONIZ, et al., Respiratória de Trabalhadores Expostos a Metais, Proceedings of the National Congress of Pneumology, Espinho, Portugal, 10–15 November 1999 (in Portuguese).

FREITAS, M.C., PINHEIRO, T., ALVES, L.C., MONIZ, D., ALVAREZ, E., et al., Biological Monitoring of Mercury and Toxic Elements in Steel Workers, Proceedings of the Mercury as a Global Pollutant — 5<sup>th</sup> International Conference, Rio de Janeiro, Brazil, 23–28 May 1999.

FRONTASYEVA, M.V., GORBUNOV, A.V., GINDORINA, S.F., LYAPUNOV, S.M., OPREA C.D., Workplace Monitoring and Occupational Health Studies at the Centre for Production of Phosphorus Moneral Fertilizers, Voskresensk (Moscow Region, Russian Federation), Using Nuclear and Related Techniques, Dubna, Russian Federation, Part II, Joint Institute for Nuclear Research (JINR), E14 (1999) 99–68.

MENEZES, M.Â.B.C., SABINO, C.V.S., AMARAL, A.M., MATTOS, S.V.M., FILHO, et al., Galvanizing Industry: Evaluation of Contamination Level Using Biomonitoring, Congresso Geral em Energia Nuclear, 7 (General Conference on Nuclear Energy), 31<sup>st</sup> Aug.–3<sup>rd</sup> Sept. 1999, Belo Horizonte, Proceedings, Belo Horizonte: Associação Brasileira de Energia Nuclear (Brazilian Association for Nuclear Energy) (1999) CD-ROM.

PINHEIRO, T., FREITAS, M.C., ALVES, L., SANTOS, A.C., HIPÓLITO, C.S., Monitorização Ambiental e Biológica de Trabalhadores Expostos a Metais Proceedings of the 6th Environment National Conference, Lisbon, Portugal, 19–21 October 1999 (in Portuguese).

PINHEIRO, T., ALVES, L.C., BUGALHO DE ALMEIDA, A., PALHANO, M.J., PALSGARD, E., et al., Airborne particulate matter localisation in the human respiratory system, Nucl. Instr. Meth. B. **158**(1-4) (1999) 499–504.

TEJRAL, J., FIALA, Z., BENCKO, V., ŠMEJKALOVÁ, J., SRB, V., TMĚJOVÁ, M., BORSKÁ, L., ANDRÝS, C., KUČERA, J., Health status of persons occupationally exposed to chromium, nickel, manganese and polycyclic aromatic hydrocarbons, Acta Medica (Hradec Králové) **42**(Suppl.) (1999) 65–69 (in Czech).

KUČERA, J., BENCKO, V., Normal concentrations of trace elements in the Czech and Slovak populations for biomonitoring purposes, Part I: Al, As, Cd, Co, Cr, Cs, Cu, F, Mn and Ni in blood, serum and urine (in Czech), Pracov, Léč (Prague) **49** (1997) 68–78.



# **WORKPLACE AND OCCUPATIONAL HEALTH: THE FIRST METAL EVALUATION USING NUCLEAR AND ANALYTICAL TECHNIQUES IN THE STATE OF MINAS GERAIS — BRAZIL**

M.Â. DE BARROS CORREIA MENEZES<sup>1</sup>, E.C. PEREIRA MAIA<sup>2</sup>,  
C. DE V. S. SABINO<sup>1</sup>, J.R. BATISTA<sup>1</sup>, O.F. NEVES<sup>1</sup>, C. ALBINATI<sup>3</sup>,  
S.S. FILHO<sup>3</sup>, S.V. DE M. MATTOS<sup>4</sup>

<sup>1</sup> Centro de Desenvolvimento da Tecnologia Nuclear/CDTN, Comissão Nacional de Energia Nuclear/CNEN, Belo Horizonte, Brazil

<sup>2</sup> Universidade Federal de Minas Gerais, Departamento de Química, Belo Horizonte, Minas Gerais, Brazil

<sup>3</sup> Secretaria Municipal de Saúde de Belo Horizonte, Coordenação de Saúde do Trabalhador, Belo Horizonte, Brazil

<sup>4</sup> FUNED, Divisão de Bromatologia e Toxicologia, Serviço de Química Especializada, Belo Horizonte, Brazil

## **Abstract**

The man and the environment are constantly exposed to contamination risks. Industrial activities have been the target of some studies because industrial processes are a constant source of contamination to the workmen. Belo Horizonte and its surrounding areas are an important industrial centre. The majority of patients who look for medical assistance because of metal contamination are working in a galvanizing industry. This investigation project was the first action in order to assess the elemental concentration levels in the galvanizing industry and alert for the need to assess the outcome of a long-term exposure. Scalp hair, toenails and urine samples were used as bioindicators in order to assess health risks evaluating the contamination levels among the workers. Besides biomonitors the industry environment was evaluated through analysis of airborne particulate matter. This work is related to an IAEA Coordinated Research Project whose goal is to make a survey of the exposure to metals related to occupational diseases. It has been conducted by CDTN/CNEN and governmental health departments. The elemental concentration results have pointed out a high exposure to pollutants at workplaces and a high elemental concentrations in biomonitors suggesting endogenous contamination. Medical recommendations were made aimed at minimising its hazardous effects on men's health.

## **1. INTRODUCTION**

During daily activities the man is exposed to various substances, toxic or not [1, 2], that can be incorporated by digesting, inhaling and through the dermas. A continuous exposure accumulates the chemicals leading to an exposure dose and risks causing diseases and death. As the man is exposed to the environment, the industry has been the target of studies because industrial processes continuously introduce contamination risks to workers. The easiest processes to be identified are those that kill or mutilate. Other processes take time to produce sinister effects, and because of that contamination is difficult to be identified. There are nearly 15,000 chemical and physical toxic agents commonly used in industries but there are some legal rules of exposition for only about 5% of them. The effects may not appear in a short time. With more modern processes, new chemical agents enlarge the list of pollutants whose effects are still unknown [3].

Statistical surveys about occupational diseases in Brazil refer to accidents and damages and not to the occupational diseases developed through long exposures to hazardous working conditions. Documented cases refer only to dangerous conditions or damages. The workplace



exposures are registered when the acquisition of the disease is obvious or probable, that is, dangerous diseases easily identified. The major problem is that the great part of workers is exposed to low levels of toxic chemicals that can be lethal in a long period of time, due to chronic diseases. Most often the onset of the diseases goes unnoticed and the presence of lung cancer or heart diseases is attributed to non-occupational causes. As a result, these diseases do not become part of the compiled data [3].

To make an occupational related diagnosis is complex because of the difficulty to identify and characterise the expositions. Physicians do not usually have access to the quantity of raw material managed by the worker, dates, period of exposure to the substance. Besides this the onset of occupational diseases is similar to other chronic diseases. There are no careful investigations in Brazil to identify occupational causes. There is not a specialised and complete literature about occupational aetiology and neither an evaluation of the onset of the disease linked to a long-term exposure to low levels of toxic agents [4].

Among the toxic substances, there are metals present in the environment that may cause from allergies to cancer to dangerous intoxication. The Law No. 24 (December 29th, 1994) from the Secretaria de Segurança e Saúde no Trabalho (Department of Security and Health at Work), Brazil, approved the NR-7 Program of Medical Control of Occupational Health [5], in which the Maximum Biological Levels Allowed and the Values of Normality References are established. Concerning metals only few elements are mentioned and their limited level values are established. In this case it is recommended to apply the American Conference of Governmental Industrial Hygienists values [6] but this guide is not complete.

## 2. OBJECTIVE

This project aimed at assessing metal levels in a galvanizing industry by means of biomonitors and airborne particulate matter collected in air filters. The analyses of air filters, scalp hair and toenail samples were carried out by  $k_0$  parametric neutron activation analysis,  $k_0$ -PNAA. Urine samples were analysed by graphite furnace atomic absorption spectrophotometry, GFAAS.

This project has been conducted together with the physicians of the Secretaria Municipal de Saúde (Municipal Department of Health) and researchers from Fundação Ezequiel Dias, an official institute involved with public health. It is inserted in a Worker's Health Awareness Program.

## 3. ASSESSMENT

The levels of exposure can be measured when studying metals associated with occupational diseases using biological monitors. These bioindicators assess the health risk through the evaluation of the level of incorporation or exposure [7, 8]. Biological materials reflect the presence of many chemicals in the organism. The elements can be carried by the blood and urine or stored in the hair and nails. While contaminated blood and urine reflect recent exposure, hair and nail show the contamination occurred some time ago [9].

There are some controversies about a normal, acceptable range of values for the population. The literature has indicated hair and nails as suitable bioindicators of primary metal content in the organism. These biomonitors have been considered a useful tool to diagnose some diseases caused mainly by contamination [7–11]. Besides biomonitors, it is important to assess health risk evaluating the industry environment through airborne particles. Elevated levels of these particles are correlated with adverse health effects, including increased occurrence of respiratory symptoms, impairment of pulmonary function, and internal body contamination. In order to assess the level of pollution inside the workplace, particulate matter collected on air filter was analysed.

#### 4. STUDIED INDUSTRY

Belo Horizonte and surrounding areas are an important industrial centre, concentrating many industries in several areas. Considering the hazard involving chemical elements, contamination by metals is a health hazard among workers of different plants. However there are no records of the level of metal concentration in the environmental air in industry, not even any records of the level of contamination of factory workers.

Only in Belo Horizonte there are more than 20 galvanizing industries ranging from home factories to well equipped ones. This industry was chosen as object of this project because it is responsible for the majority of patients who look for medical assistance because of metal contamination.

Galvanisation [12–15] is an electroplating process of depositing a coating on a desirable form by means of electrolysis. The ordinary steps are: polishing with abrasives, washing with acids and sodium hydroxide and electroplating of aluminium, cadmium, chromium, cobalt, copper, gold, indium, iron, lead, nickel, platinum, silver, tin or zinc. This requires several workers such as polishers, platers and cleaners. The polishers handle all the items before the electrodeposition, polishing them either manually or mechanically. The platers are responsible for the chemical cleaning and the electrodeposition. The cleaner washes the items with water, dries them with sawdust and also performs other tasks as to organize the clients' orders.

#### 5. EXECUTION

The evaluation of how many galvanizing industries there were in Belo Horizonte had been done by the Departamento de Metalurgia da Universidade Federal de Minas Gerais (Metallurgical Department). Out of the total number of industries found, 70% are small ones. This means that they hire from 5 to 19 workers. [13].

In order to have a representative sampling in terms of the number of industries to be studied and the number of workers that would donate the biological samples, a statistical study was performed [16]. The sample size of the Comparative Group obtained was 16. It means that the Comparative Group will be formed of at least 16 people that do not work in galvanizing industry. Concerning the Workers Group, it was calculated that the Workers Group would be 25 workers.

## **5.1. Pilot sampling**

The objective of this sampling was to verify the metal exposure level inside the workplace. A downtown factory was chosen at random. The scalp hair samples were collected from 7 workers in the small industry, including officers, platers, item washers and polishers. Some of them also donated fingernails. The washed and unwashed hair samples and unwashed fingernail clippings were analysed. The results [17–19] pointed out that all the elemental concentrations in the workers' hair were higher than the Human Hair Reference Material [20]. They showed a higher concentration in unwashed hair compared to washed hair samples, and a high elemental concentration in fingernails, proving the polluted environment inside the factory. Among the workers, the Polishers present the worst situation in terms of contamination.

## **5.2. Description of galvanizing chosen**

### Galvanizing 1

This factory plates chromium, nickel and copper. Eventually it plates silver and gold. The areas for polishing, baths, items support preparation, acid cleaning, reception desk and offices are located on the ground floor. There is physical separation among polishing and bath areas, from bath area to items support preparation area and from this to the reception desk and the offices. The acid cleaning is inside the bath area. On the first floor, there is another acid cleaning area, one small kitchen, one small storeroom and workers' private area.

### Galvanizing 2

This galvanizing plates chromium, nickel, silver, gold and copper. The reception desk, acid cleaning, items support preparation and the bath areas are located on the ground floor without any physical separation. The polishing is on the second floor.

### Galvanizing 3

This galvanizing plates chromium, nickel, silver, gold and copper. The office, reception desk, polishing and the bath areas are located on the ground floor. The acid cleaning and the items support preparation procedures are done in the bath area. There is a physical connection among the polishing area and reception desk and the bath area, and from the bath area to the reception desk and from there to the office and the street. The plant occupies a small area, around 100 m<sup>2</sup>. There is only one window in the bath area. The electric fans on the ceiling of the polishing and in the bath areas contribute to spread the elements and contaminate all the plant. As the areas are very close, the dust is present everywhere.

## **5.3. Sampling procedures**

### *5.3.1. Airborne Particulate Matter*

Stationary air sampling was carried out in order to evaluate the level of elemental concentration in the indoor environment of the plants. The sampling of airborne particulate matter (APM) was conducted at three different galvanizing, by using 0.8- $\mu$ m pore size, 37 mm diameter, and 5.0  $\mu$ m pore size, 37 mm diameter, housed in polystyrene cassettes. The respective cassettes were attached to constant air-flow sampling pumps, SKS, Eighty Four,

PA 15330, USA, PCXR8KD. Both air-sampling pumps were calibrated before use to ensure accuracy of the volume of air sampled,  $4 \text{ L/min}^{-1}$ . Each of the two samples, one with  $0.8 \mu\text{m}$  and another with  $5.0 \mu\text{m}$  pore size, collected the APM simultaneously at the same place. As the primary objective of the study was to obtain information regarding workmens' exposure, the samples collected came from places that would reflect, as much as possible, the indoor environment: near the polishing activities, as close to the chrome and copper baths as possible, in the office and in the items reception desk.

The sampling was performed for 8 hours during two days. The results of the air samplings are presented on Tables I, II and III, related to Galvanizing 1, 2 and 3, respectively. The fine fraction correspond to APM having equivalent aerodynamic diameter less than  $5 \mu\text{m}$  and coarse fraction, more than  $5 \mu\text{m}$ . Tables I, II, and III bring the Threshold Limit Values, TLV, according to ACGIH [6] and the elemental concentrations determined in APM. In general the results point out that the polishing areas are more exposed to several elements. Table IV shows how many elemental concentrations were determined, how many of them were in the range of the TLV, how many of these exceeded the correspondent TLV and their percentage [11].

TABLE I: GALVANIZING 1: APM ELEMENTAL CONCENTRATIONS (mg/m<sup>3</sup>)

Element	TLV	Office		Bath Area		Polishing Area	
		Breathable Fraction	Inhalable Fraction	Breathable Fraction	Inhalable Fraction	Breathable Fraction	Inhalable Fraction
Ag metal	0.1	ND	ND	ND	ND	ND	ND
Al fume dust	5 10	0.025±0.003	ND	0.18±0.04	0.40±0.02	1.82±0.04	2.36±0.04
As metal and compounds	0.01	ND	ND	0.0002±0.0001	ND	0.0012±0.0002	ND
Au	NF	ND	ND	0.000002±0.000002	0.0000004±0.0000004	0.00004±0.00001	0.00007±0.00001
Cl chlorine	14	ND	ND	0.13±0.01	ND	4±1	ND
Co metal and compounds	0.02	ND	ND	ND	ND	0.003±0.001	0.0010±0.0005
Cr metal and Cr III compounds	0.5						
water-soluble Cr VI compounds	0.05	0.070±0.001	0.060±0.001	0.014±0.001	0.013±0.001	0.040±0.004	0.007±0.005
insoluble Cr IV compounds	0.01						
Cu fume dust & mist	0.2 1	ND	ND	ND	ND	0.24 ± 0.04	ND
Fe oxide dust & fume	5	0.030±0.003	0.15±0.08	1.2±0.1	0.23±0.03	15±1	6±1
Mn metal & compounds	0.2	0.003±0.001	0.0013±0.0001	0.0010±0.0005	ND	0.09±0.01	0.12±0.04
Na	NF	0.004±0.002	0.027±0.002	0.034±0.001	ND	ND	0.27±0.02
Sb metal & compounds	0.5	0.0003±0.0001	ND	ND	ND	ND	ND
Sc	NF	ND	ND	ND	ND	0.0001±0.00005	0.0001±0.00002
Zn fume dust	5 10	0.007±0.004	0.011±0.003	0.015±0.001	ND	0.013±0.005	0.19±0.01

ND – not detected; NG – not given

TABLE II: GALVANIZING 2: APM ELEMENTAL CONCENTRATIONS (mg/m<sup>3</sup>)

Element	TLV	Reception Desk		Bath Area		Polishing Area	
		Breathable Fraction	Inhalable Fraction	Breathable Fraction	Inhalable Fraction	Breathable Fraction	Inhalable Fraction
Ag metal	0.1	0.005±0.002	ND	0.012±0.003	ND	ND	ND
Al fume dust	5 10	0.72±0.01	0.12±0.01	0.37±0.01	0.39±0.01	1.8±0.1	0.46±0.01
As metal & compounds	0.01	0.0020± 0.0001	0.0009± 0.0001	0.0020± 0.0001	0.0070± 0.0001	0.007±0.001	0.006±0.001
Au	NF	0.00009± 0.00002	0.000022± 0.000001	0.00004± 0.00001	0.000030± 0.000002	0.00007± 0.00001	ND
Cl chlorine	14	1.2±0.1	ND	27±1	ND	ND	ND
Co metal & compounds	0.02	ND	ND	ND	ND	0.009±0.001	0.0014±0.0003
Cr metal and Cr III compounds	0.5						
water-soluble Cr VI compounds	0.05	0.251±0.001	0.011±0.001	0.013±0.002	0.050±0.002	0.15±0.01	0.066±0.005
insoluble Cr IV compounds	0.01						
Cu fume dust & mist	0.2 1	0.13±0.01	0.06±0.02	0.03±0.01	0.15±0.01	8.5±0.3	0.05±0.01
Fe fume & dust	5	0.3±0.1	ND	0.4±0.1	ND	167±2	36±1
Mn metal & compounds	0.2	0.003±0.001	0.003±0.002	0.003±0.001	0.001±0.001	0.62±0.02	0.025±0.002
Na	NF	0.325±0.001	ND	ND	0.144±0.002	7±1	0.082±0.004
Sb metal & compounds	0.5	ND	ND	ND	ND	0.002±0.001	0.0013±0.0004
Zn fume dust	5 10	0.057±0.003	0.031±0.003	0.05±0.01	ND	1.5±0.1	3.0±0.1

ND – not detected; NG – not given

TABLE III: GALVANIZING 3: APM ELEMENTAL CONCENTRATIONS (mg/m<sup>3</sup>)

Element	TLV	Reception Desk		Office		Bath Area		Polishing Area	
		Breathable Fraction	Inhalable Fraction	Breathable Fraction	Inhalable Fraction	Breathable Fraction	Inhalable Fraction	Breathable Fraction	Inhalable Fraction
Ag metal	0.1	0.018±0.004	0.07±0.01	0.03±0.02	ND	0.43±0.01	0.57±0.02	4.0±0.4	0.15±0.04
Al fume dust	5 10	0.02±0.01	0.11±0.01	2.14±0.01	0.17±0.04	ND	0.50±0.02	2.40±0.04	0.61±0.03
As metal & compounds	0.01	0.007±0.002	ND	ND	ND	0.012±0.002	0.005±0.002	0.15±0.03	ND
Au	NF	0.3660±0.0001	0.0040±0.0001	0.002±0.001	0.0020±0.0002	0.0030±0.0002	0.0100±0.0002	0.07±0.001	0.012±0.001
Cl chlorine	14	0.08±0.02	ND	10±1	ND	33±1	ND	126±6	ND
Co metal & compounds	0.02	0.004±0.004	0.010±0.004	0.004±0.002	ND	ND	0.029±0.003	0.02±0.01	0.06±0.01
Cr metal and Cr III compounds	0.5								
water-soluble Cr VI compounds	0.05	0.04±0.01	0.13±0.03	0.38±0.01	0.14±0.06	2.06±0.02	0.07±0.04	1.5±0.1	6.2±0.2
Insoluble Cr IV compounds	0.01								
Cu fume dust & mist	0.2 1	2.25±0.04	0.05±0.01	0.50±0.04	ND	0.21±0.07	0.33±0.03	4.7±0.2	ND
Fe fume & dust	5	31±3	7±2	10±3	9±4	229±1	132±5	ND	282±15
La	NF	ND	ND	ND	ND	ND	ND	1.5±0.3	ND
Mn metal & compounds	0.2	0.018±0.001	0.007±0.001	0.011±0.002	ND	ND	0.020±0.005	0.03±0.01	0.006±0.002
Na	NF	0.05±0.01	0.5±0.1	0.56±0.03	0.04±0.03	0.50±0.04	1.50±0.04	3±1	0.25±0.07
Sb metal & compounds	0.5	0.002±0.001	0.011±0.002	0.012±0.003	0.004±0.004	0.06±0.03	0.025±0.005	0.06±0.01	0.04±0.01
Zn fume dust	5 10	1.2±0.2	0.9±0.2	1.2±0.2	0.4±0.1	20±1	7.3±0.4	106±1	14±1

ND – not detected; NG – not given

TABLE IV: GENERAL ASSESSMENT OF RISKS

Galvanizing	Workplace	Number of Elemental Determinations	Number of Elemental Determinations in the Range of TLV	Exceeding the TLV	
				No. of Occurrences*	%
1	Office	12	10	2	20
	Bath	13	10	2	20
	Polishing	20	15	5	33.3
	Total	45	35	9	25.7
2	Reception Desk	18	15	2	13.3
	Bath	17	14	3	21.4
	Polishing	21	18	6	33.3
	Total	56	47	11	23.4
3	Office	19	15	5	33.3
	Reception Desk	24	20	5	25
	Bath	22	18	10	55.6
	Polishing	23	18	11	61.1
	Total	88	71	31	43.7
Grand Total		189	153	51	33.3

\* related to element which has correspondent TLV

### 5.3.2. Workers Group

The sampling of the Workers Group (WG) were carried out in each factory, after the physicians had explained to workers the aims of the project and how it would be performed. It was decided to carry out the sample collecting on a Friday due to the simultaneous urine collecting. In the First RCP Meeting [19] it was decided to collect the urine on the last work day of the week and at the end the shift because of the metal elimination rate. Urine was also collected the next Monday, just before work began in order to compare the metal concentrations. Instructions were issued and followed in order to avoid external contamination. The volunteer workers donated their hair samples collected according to the IAEA instructions [8], from the nape with scissors. They wore short hair cut due to the air pollution inside the factory. The toenails were also collected as well the urine.



### 5.3.3. Comparative Group

Comparative Group (CG) sampling was carried out the same way as WG for scalp hair and toenails. This group was formed by individuals not exposed to the same galvanizing environment. The urine was collected only once.

## 5.4. Preparing the samples for analysis

After the APM sampling the cassettes were carefully opened. The air filters were folded and inserted into their respective polyethylene tube for irradiation.

Some of the Workers Group hair samples were irradiated without washing. This procedure aimed at verifying the level of metal external contamination. The other scalp hair samples, from both WG and CG were washed as suggested by IAEA [8]. The procedure consisted of washing each sample in a clean beaker by mechanical agitation with 25 mL portions of, successively, water, acetone, water, water, acetone, water, decanting the wash liquid after 10-minute wash. After washing the samples were dried at 40°C and weighed in the irradiation container.

The toenails from both groups were washed using the procedure agreed upon during in the 1<sup>st</sup> Meeting [19] of this Coordinated Research Project. The procedure involved 6 steps of washing each sample in a clean beaker in an ultrasonic bath, with 25 mL portions of, successively, water, acetone, 1% detergent solution, water, water, acetone, water, decanting the wash liquid after 10-minute wash [21]. After washing the samples were air dried and weighed into the irradiation container.

The urine samples were collected in polyethylene flasks and an aliquot of 5 mL was taken to determine the creatinine concentration. After that an aliquot of 25 mL from each worker's sample was taken into a glass flask, frozen and lyophilised. This procedure aimed at concentrating the elements and reaching better detection limits.

The biological materials from the Comparative Group were also collected in the same way. Only one urine sample was collected from each individual. One aliquot of 50 mL was lyophilised.

## 5.5. Analysis

### 5.5.1. $k_0$ Parametric Neutron Activation Analysis ( $k_0$ PNAA)

The irradiations were performed in the reactor TRIGA MARK I IPR-R1 in the CDTN at 100 kW, thermal neutron flux  $6.6 \times 10^{11} \text{ n.cm}^{-2}.\text{s}^{-1}$ . Several certified reference materials have been analysed by means of the  $k_0$ PNAA in order to verify the efficiency of the method using the TRIGA MARK I IPR-R1' s parameters, using Au and Na comparators. The Høgdahl convention was used [22, 23]. Some of the certified reference materials analysed were: IAEA Soil-7 (International Atomic Energy Agency), GBW 08303-Polluted Farmland Soil (Beijing Municipal Environmental Monitoring Centre), BCR-176-Trace Element in a City Waste Incineration Ash (Community Bureau of Reference), GXR-3, GXR-6 (United States Geological Survey) and GBW 09101-Human Hair (Shanghai Institute of Nuclear Research). The overall accuracy was 1–5% [18].

The elements were determined through three schemes of irradiation: 5 min irradiation time, 2 to 15 min of decay time and 600 s of measurement time to determine Al, Cu, Mn, Ti and V; 4 hours irradiation time, 12 hours of decay time and 3 hours of measurement time to determine As, Au, La and Na; 20 hours irradiation time, 10 days of decay time and 4 hours of measurement time to determine Co, Cr, Cs, Fe, Ga, Rb, Sb, Sc and Zn [17, 18].

After the suitable decay time, the gamma spectrometry was performed using a HPGe detector ORTEC, 10175-P, resolution of 1.85 keV at the 1332 keV peak of  $^{60}\text{Co}$ , associated electronic and Genie PC, CANBERRA, gamma spectrum analysis software. The elemental concentration calculations were performed according to the  $k_0$  parametric neutron activation method [23].

### 5.5.2. Atomic Absorption Spectrometry

During a preliminary urine analysis using qualitative neutron activation analysis, it was verified that this nuclear analytical method would not be appropriate due to the high elemental concentrations of some interfering elements such as Cl, Na, K, Cs and others. It was decided to determine some elements in urine using Graphite Furnace Atomic Absorption Spectrometry (GFAAS) [12, 24]. According to the literature [17] an aliquot of 5mL was taken from each urine sample and diluted five times with water and added 0.25 mL high pure 65%  $\text{HNO}_3$ . The elemental concentrations were determined using an Analyst 300 Atomic Absorption Spectrometer with Graphite Furnace HGA-800, Perkin Elmer, including the AS-72 Autosampler.

## 6. STATISTICAL ANALYSIS

The analysis of metal content in the biomonitors is expected to give different kinds of information. One way to apply the multivariate analysis [16, 25–27] of the whole data set, takes into account the correlation of all variables simultaneously, that allows extracting a lot of information. The most commonly used one is the principal component analysis (PCA). This powerful technique is aimed at finding out a small number of generalised variables, or factors, which can describe most of the variances and correlations of the initial variables without loss of information. For multivariate analysis the data are usually represented in a matrix form, where a row shows the values of all the variables that describe one of the subjects. Due to the higher variability of the concentrations it is needed to normalise the variable distributions. A new data set is derived, having as working variables the logarithms of the elemental concentrations. This method has been used to solve many problems in several areas of science.

For completing the statistical analysis, one-way ANOVA procedure can be used to evaluate the influence of independent groups and the variables. Student t-test can also be applied to compare variables in order to verify the similarity between groups. Correlation analysis can also be performed in which the correlation between variables is described in terms of the correlation coefficients ranging from  $-1$  to  $1$ . The closer as to  $-1$  or  $1$ , the higher the correlation is.

The multivariate analysis technique, analysis of variance through ANOVA, t-test and Pearson Correlation analysis were applied in this investigation using the SYSTAT<sup>®</sup> program [28]. The considered variables were the normalised concentrations of Ag, Al, As, Au, Br, Cl, Co, Cr, Cu, Fe, Hg, La, Mn, Na, Sb and Zn determined in scalp hair and Ag, Al, Au, Cl, Cr, Cu, Fe,

Mn, Na and Zn determined in toenail samples. Other elements such as Hf, Ta, Ti, Sc and V found in hair were not included since only few samples presented these elements, as well as As, Br and Sb found in toenails. The elements Co, Hg and La were not detected in toenail samples. It is important to emphasise that the workers do not deal with Br, Hg and Na during the galvanizing procedures but they were included in multivariate analysis because of the possibility of correlation and interaction, as chemicals, with the other elements coming from the industrial processes.

In order to apply the technique, the samples were classified into the following independent classes: galvanizing (1, 2 and 3), activity (1, officer; 2, item cleaner and trainee; 3, platers; 4, polishers and 5, owners), time working in present activity (1, 0.5 to 3 years; 2 from 4 to 7; 3 from 8 to 10; 4 from 11 to 14; 5 from 15 to 20 and 6 over 20), drinking (1 if not; 2 if yes), smoking (1 if not; 2 if yes), matrix (1 hair and 2 nail) and group (1 Workers Group; 2 Comparative Group).

## 7. QUALITY CONTROL

The quality control was done involving several procedures such as replicates of samples analysed whenever possible. Various certified reference materials have been analysed by means of  $k_0$ PNAA in order to verify the efficiency of the method using the TRIGA MARK I IPR-R1' s parameters according to what was said before. All the hair and toenail samples were irradiated simultaneously with Human Hair Reference Certified Material. The airborne particulate samples were accompanied by IAEA Soil-7 (International Atomic Energy Agency), GBW 08303-Polluted Farmland Soil (Beijing Municipal Environmental Monitoring Centre), BCR-176-Trace Element in a City Waste Incineration Ash (Community Bureau of Reference) reference materials. The urine analyses were checked by SRM 2670, Toxic Metals in Freeze-Dried Urine from NIST.

The participation at relevant interlaboratory comparison studies organized by IAEA on determining trace elements in filters loaded with airborne particulate matter, urban dust, filters loaded with welding fume and lyophilised urine was another quality control procedure [19, 29].

## 8. DISCUSSION OF RESULTS

### 8.1. Airborne particulate matter

Observing the elemental concentrations determined in airborne particulate matter shown in Tables I, II, and III, taking into account the distribution of the working areas and the kind of metal electrodeposited in each galvanizing, it is possible to conclude that:

### **Galvanizing 1:**

- In the polishing area, the elements Al, Co, Fe, Mn, Sc and Zn originate from the metal structure of the items to be galvanised; As, Au and Cu from the previous coating on the items; Cr originates not only from the previous coating, but, possibly, also from the bath area; Cl from the bath and acid cleaning;
- In the bath area, Al, As, Au, Fe, Mn and Zn, possibly originate from the polishing procedure; Cr from the bath itself; Cu was not detected and Cl originates from the bath and acid cleaning;
- In the office, Al, Fe, Mn, Sb and Zn presence, at very low concentration, possibly originate from outside but Cr concentration, higher than in the bath, possibly originates not only from outside but also from the bath as mist formed during the plating process. As in this place there is no window and connection is only through the reception desk in front of the street, the mist may be retained in the office.

### **Galvanizing 2:**

- In the polishing area, all the elements determined came from the items or the previous coating; Cl was not detected;
- In the bath and acid cleaning areas, reception desk and items support preparation area, Ag, As, Au, Cl, Cr, and Cu originate from the plating; Al, Fe, Mn and Zn at low concentrations, possibly from outside the plant since this area is completely open to the street.

### **Galvanizing 3:**

- In the polishing area, all the elements determined originate from the items or the previous coating or from the bath area;
- In the bath area that contains the acid cleaning and items support preparation, Ag, As, Au, Cl, Cr, Cu and Sb originate from the plating; Al, Co, Fe, Mn and Zn probably from the polishing;
- In the office and reception desk, the elements originate from the polishing, the bath areas and a little from outside.

Table IV shows that most of the values exceeding the TLV were determined in the Galvanizing 3. This sampling indicates the hazards which the workers are exposed to in their workplaces day by day.

## **8.2. Comparative group**

Elemental concentrations determined in the samples from non-exposed people [30] are shown in Table V. Reference 1 [10] scalp hair values represents individuals living in São Paulo city, Brazil, and Reference 2 [31] reports results on fingernails. As reference values for toenails were not found, it was decided to compare them with fingernails to give an idea about the concentration levels.

TABLE V: COMPARATIVE GROUP: CONCENTRATIONS DETERMINED IN THE STUDY AND LITERATURE VALUES

Element	Scalp Hair (µg/g)				Toenail (µg/g)		
	Comparative Group (22 individuals)		Reference 1 [10] (35 individuals)		Comparative Group (22 individuals)		Reference 2 [31] (fingernails) [mass fraction]
	Range	n	Range	n	Range	n	Range
Al	5–104	21	1.60–37.4	35	ND	–	(132–927) x10 <sup>-6</sup>
As	ND	–	(0.0067–0.126)*	35	ND	–	(0.2–1.05) x10 <sup>-6</sup>
Au	0.002–0.27	12	ND	–	0.001–0.036	6	(0.03–0.78) x10 <sup>-6</sup>
Br	0.08–2.1	22	0.42–85.4	28	ND	–	(9–10) x10 <sup>-6</sup>
Cl	23–809	19	40.7–1339	33	ND	–	(109–357) x10 <sup>-7</sup>
Co	ND	–	(0.008–0.325)*	33	0.2–0.3	5	< 0.2 x10 <sup>-6</sup>
Cr	0.7–17	6	(0.068–0.753)*	32	1.6–4	3	6.2 x10 <sup>-6</sup>
Cu	3–46	21	4.0–56	35	ND	–	(11.2–53) x10 <sup>-6</sup>
Fe	ND	–	7.2–37	33	78–323	4	(27–347) x10 <sup>-6</sup>
Hg	0.3–5	15	0.08–4.75	35	0.2–1.4	5	(0.07–7.27)x10 <sup>-6</sup>
Mn	1.2–1.7	2	(0.105–2.50)*	35	ND	–	(0.04–2.1) x10 <sup>-6</sup>
Na	0.7–22	19	1.50–30	35	ND	–	(332–3010) x10 <sup>-6</sup>
Sb	ND	–	(0.003–0.85)*	33	ND	–	(0.03–0.75) x10 <sup>-6</sup>
Sc	ND	–	(0.0012–0.006)*	14	0.004–0.1	15	NR
V	ND	–	(0.0015–0.054)*	9	ND	–	<0.15 x10 <sup>-6</sup>
Zn	120–280	22	105–264	32	57–2100	19	(73–304) x10 <sup>-6</sup>

ND, Not Detected; n, number of values determined; NR, Not Reported; \* (ng/g)

By comparing the results, it is possible to verify that in general there are no significant differences between the values among different groups. The variations are due to diet, personal hygiene habits, environment and other influences. Table VI shows the results of urine samples and gives literature values. The following elements were determined: Cr, because it is the most important contaminant in galvanizing industry, and Cu and Fe due to their presence in most workers' hair and toenails. The objective was to evaluate the concentrations in urine as an important vehicle of excretion.

TABLE VI: COMPARATIVE GROUP: URINE ELEMENTAL CONCENTRATIONS DETERMINED AND LITERATURE VALUES ( $\mu\text{g/L}$ )

Element	Comparative Group (22 individuals)		Reference [31]
	range	n	range
Cr	<10	20	0.7–12
Cu	<7	20	17–300
Fe	<10	20	180

n, number of values determined;

### 8.3. Workers group

In tables VII and VIII results for hair and toenails are presented. They are arranged according to different galvanizing plants and sample types. Table IX shows results for urine analysis along with the Biological Exposure Indices, BEI for Cr [6]. The Cr urine concentrations are higher in the Workers Groups compared to the Comparative Group, but do not exceed the BEI value.

Except for Br, Hg and Na, where concentrations found for Workers Group are similar to those determined in Comparative Group and do not come from the industrial process, the concentrations of other elements, in general are higher in the Workers Group demonstrating the high exposure to pollutants.

TABLE VII: ELEMENTAL CONTENT IN HAIR SAMPLES OF COMPARATIVE AND WORKERS GROUPS. VALUES ARE IN  $\mu\text{g/g}$

Element	Comparative Group (22 individuals)			Galvanizing 1 (9 workers)			Galvanizing 2 (9 workers)			Galvanizing 3 (7 workers)		
	$x_G \pm s_G$	range	n	$x_G \pm s_G$	range	n	$x_G \pm s_G$	range	n	$x_G \pm s_G$	range	n
Ag	ND	–	–	$4 \pm 1$	3–8	7	$2 \pm 1$	0.4–2.4	9	$3 \pm 4$	0.3–50	6
Al	$18 \pm 1$	5–104	21	$255 \pm 3$	42–2190	8	$65 \pm 2$	5–385	9	$149 \pm 2$	33–390	5
As	ND	–	–	ND	–	–	$0.2 \pm 1.4$	0.07–0.06	7	ND	–	–
Au	$0.02 \pm 3$	0.002–0.2	12	$0.1 \pm 1.3$	0.024–0.17	8	$0.4 \pm 1.4$	0.050–0.79	9	$0.5 \pm 2.0$	0.03–4.4	6
Br	$0.5 \pm 1.5$	0.08–2.1	–	$0.6 \pm 1.2$	0.3–1.2	8	$1 \pm 1$	0.16–1.9	7	$1 \pm 1$	0.24–1.3	4
Cl	$127 \pm 2$	23–809	19	$244 \pm 2$	60–600	5	$33 \pm 1$	8–63	5	$246 \pm 1$	92–454	4
Co	ND	–	–	$0.2 \pm 1$	0.01–0.2	7	$0.2 \pm 1.1$	0.07–0.28	5	$5 \pm 2$		1
Cr	$3 \pm 2$	0.7–17	6	$5 \pm 1$	2–14	8	$11 \pm 2$	3–67	9	$4 \pm 5$	0.3–63	6
Cu	$13 \pm 1$	3–46	21	$147 \pm 2$	23–590	9	$196 \pm 2$	90–882	9	$494 \pm 2$	113–1637	5
Fe	ND	–	–	$341 \pm 3$	75–1974	9	$754 \pm 3$	238–12587	7	$296 \pm 2$	102–540	3
Hf	ND	–	–	–	1.4–4	2	ND	–	–	ND	–	–
Hg	$1 \pm 2$	0.3–5	15	$1 \pm 1$	0.6–0.8	3	$1 \pm 2$	0.2–4.6	7	ND	–	–
La	ND	–	–	$0.2 \pm 2$	0.04–0.13	7	$1 \pm 1$	0.6–1	3	ND	–	–
Mn	$1.5 \pm 0.2$	1.2–1.7	2	$7 \pm 3$	1–8	8	$4 \pm 2$	1.1–38	9	$3 \pm 1$	1.3–4.5	4
Na	$2 \pm 2$	0.7–22	19	$7 \pm 2$	1.8–37	–	$17 \pm 3$	2.9–307	8	$2 \pm 1$		1
Sb	ND	–	–	$0.4 \pm 1.6$	0.2–2	5	$0.2 \pm 1.5$	0.03–1	7	$0.2 \pm 4.3$	0.02–1.6	6
Sc	ND	–	–	ND	–	–	ND	–	–	ND	–	–
Ta	ND	–	–	$0.2 \pm 0.1$	–	1	ND	–	–	ND	–	–
Ti	ND	–	–	$311 \pm 2$	254–380	2	ND	–	–	ND	–	–
V	ND	–	–	$11 \pm 1$	6–17	3	$0.2 \pm 1.9$	0.1–0.5	2	$0.3 \pm 0.1$		1
Zn	$235 \pm 1$	120–280	22	$121 \pm 1$	73–250	9	$270 \pm 1$	51–810	9	$122 \pm 2$	13–235	6

$x_G \pm s_G$ , geometric mean and standard deviation; n, number of values determined; ND, Not Detected

TABLE VIII: ELEMENTAL CONTENT IN TOENAIL SAMPLES OF COMPARATIVE AND WORKERS GROUPS. VALUES ARE IN  $\mu\text{g/g}$ . Hf, La, Ta, Ti AND V WERE NOT DETECTED

Element	Comparative Group (22 individuals)			Galvanizing 1 (9 workers)			Galvanizing 2 (9 workers)			Galvanizing 3 (7 workers)		
	$X_G \pm S_G$	range	n	$X_G \pm S_G$	range	n	$X_G \pm S_G$	range	n	$X_G \pm S_G$	range	n
Ag	ND	–	–	ND	–	–	$1 \pm 1$	0.9–2.4	5	$1 \pm 1$	0.5–4	4
Al	ND	–	–	$202 \pm 1$	94–638	6	$162 \pm 1$	25–448	9	$115 \pm 1$	25–229	6
As	ND	–	–	ND	–	–	$0.1 \pm 1$	0.11–0.15	2	$0.1 \pm 1.1$	0.09–0.15	2
Au	$0.002 \pm 4$	0.001–0.03	6	$0.02 \pm 1.8$	0.008–0.15	6	$0.02 \pm 3.2$	0.002–0.09	9	$0.2 \pm 1.4$	0.09–0.68	6
Br	ND	–	–	$1 \pm 1$	0.5–0.9	2	ND	–	–	$0.4 \pm 1.1$	0.3–0.6	2
Cl	ND	–	–	$512 \pm 1$	292–684	4	$188 \pm 4$	44–4480	5	$199 \pm 2$	64–447	4
Co	$0.2 \pm 1$	0.2–0.3	5	ND	–	–	ND	–	–	ND	–	–
Cr	$3 \pm 1$	1.6–4	3	$9 \pm 2$	3.4–56	5	$10 \pm 2$	2–88	8	$11 \pm 2$	3–40	6
Cu	ND	–	–	$64 \pm 1$	40–101	2	$101 \pm 1$	34–292	8	$77 \pm 1$	29–175	5
Fe	$150 \pm 1$	78–323	4	$325 \pm 1$	183–430	4	$366 \pm 1$	306–420	4	$218 \pm 1$	150–316	2
Hg	$0.4 \pm 1.3$	0.2–1.4	5	ND	–	–	ND	–	–	ND	–	–
Mn	ND	–	–	$3 \pm 1$	2–5.5	5	$4 \pm 2$	0.9–24	8	$5 \pm 2$	0.9–24	5
Na	ND	–	–	$277 \pm 1$	182–500	6	$161 \pm 1$	20–577	7	$260 \pm 2$	22–590	5
Sb	ND	–	–	$0.9 \pm 0.5$		1	$0.1 \pm 1$	0.08–0.9	6	$0.3 \pm 1.5$	0.08–0.6	5
Sc	$0.02 \pm 1.6$	0.004–0.1	15	ND	–	–	$0.03 \pm 1$	0.03–0.04	2	ND	0.03–0.04	2
Zn	$132 \pm 1$	57–2189	19	$122 \pm 1$	54–285	6	$117 \pm 1$	13–321	9	$144 \pm 1$	67–316	6

$x_G \pm s_G$ , geometric mean and standard deviation; n, number of values determined; ND, Not Detected



TABLE IX: ELEMENTAL CONTENT IN URINE FROM COMPARATIVE AND WORKERS GROUPS, VALUES ARE IN  $\mu\text{g/g creat.}$

Element	Comparative Group (22 individuals)			Galvanizing 1 (9 workers)			Galvanizing 2 (9 workers)			Galvanizing 3 (7 workers)		
	range	n	$x_G \pm s_G$	range	n	$x_G \pm s_G$	range	n	$x_G \pm s_G$	range	n	
Cr end of shift	< 10	20	$10 \pm 1$	< 10 – 15.6	9	$11 \pm 2$	< 10 – 32.8	9	$10 \pm 2$	< 10 – 13.4	7	
BEI: 30												
begin	–		$11 \pm 1$	< 10 – 16.4	7	$11 \pm 1$	< 10 – 15.4	7	$15 \pm 1$	< 10 – 56	6	
Cu end of shift	< 7	20	$19 \pm 1$	10.4 – 36.3	9	$57 \pm 1$	29.6 – 179	9	$26 \pm 1$	17 – 52.2	2	
BEI: NG												
begin	–		$16 \pm 1$	9.8 – 22.7	8	$52 \pm 1$	28 – 177.4	7	$53 \pm 1$	43 – 112.3	6	
Fe end of shift	< 10	20	NA	–	–	$153 \pm 2$	46 – 354	8	$303 \pm 2$	96 – 448	6	
BEI: NG												
begin	–	–	NA	–	–	NA	–	–	$373 \pm 1$	154 – 609	5	

$x_G \pm s_G$ , geometric mean and standard deviation; n, number of values determined; NA, Not Analysed ; BEI, Biological Exposure Indices; NG, Not Given

## 8.4. Statistical analysis

By applying Pearson Correlation, PCA rotated Quartimax, and t-Test for two groups [16], it was found that:

### 8.4.1. Biomonitor Hair from Workers' Group

- Pearson Correlation Analysis: significant positive correlations were found for Al x (Cu, Mn), Sb x (Au, As) and Fe x Mn.

PCA: the results from rotated Quartimax show that the first five principal components explained 78.5% of the total variation. It means that 78.5% of the total variance in the 16 variables measured was condensed into six new variables, the principal components, PCs.

The most significant PCs are: PC1 explains 17.9% of the total variance, where Al, Cu and Mn correlate positively and Br negatively; PC2 explains 13.3% of the total variance, where As,

Zn and Hg correlate positively and Cl and La negatively; PC3 explains 13.4% of the total variance, where Co, Fe, and La correlate positively and Cl negatively; PC4 explains 13.8% of the total variance, where Sb, Cr and Au correlate positively, and Na and Cl negatively and PC5 explains 12.0% of the total variance, where Br, Na, and La correlate positively and Au negatively.

- ANOVA and t-test for the two groups: using the PCs as variables, the least squares means for ( $p < 0.07$ ) point out that the classes are statistically different. The hair samples show that the samples are different in:
  - Galvanizing.* PC2 ( $p = 0.000$ ). The Galvanizing 2 is the only plant where majority of workers have As in their hair; PC3 ( $p = 0.065$ ), the majority of Galvanizing 1 workers have the elements that correlate positively, Co and Fe; PC5 ( $p = 0.006$ ), the Galvanizing 3 is more influenced by Au content.
  - Activity.* PC1 ( $p = 0.023$ ), the platers, the polishers and the owners that have been working more than 4 years in their specific activities have the highest Al, Cu and Mn concentrations.
  - Time working in the present activity.* PC1 ( $p = 0.052$ ), the workers who have been working more than 4 years have the highest Al, Cu and Mn concentrations.
  - Drinking.* PC4 ( $p = 0.052$ ), t-test ( $p = 0.036$ ), the ones who do not drink are more influenced by Na and Cl.

#### 8.4.2. Biomonitor Toenail from Workers Group

- Pearson Correlation Analysis: weak positive correlations were found for Cl x Fe and Cu x Ag.

PCA: the results show that the first four principal components explained 69.7% of the total variation and the 10 variables measured were condensed into four new PCs.

The most significant PCs are PC1 (21.5%, Cl and Fe correlate positively, and Al and Au negatively); PC2 (20.5%, Ag, Cu, Au and Cr correlate positively, and Fe and Mn negatively), PC3 (15.7%, Zn, Mn and Al correlate positively) and PC4 (11.7%, Na correlate positively and Cr negatively).

- ANOVA and t-test for the two groups. The toenail samples show that the samples are different in:
  - Galvanizing.* PC2 ( $p = 0.019$ ) in Galvanizing 3 is correlated with Ag and Au. The nail samples from this factory have the highest concentrations. Galvanizing 1 is correlated with Fe and Mn.
  - Activity.* PC1 ( $p = 0.043$ ). The polishers are positively correlated with Fe, actually they have the highest concentrations. Items cleaners and trainees and owners are negatively correlated. PC4 ( $p = 0.006$ ). The owners are more correlated with Cr, because they circulate inside the plant and check the electrodeposition process, where Cr is more present.
  - Smoking.* PC1 ( $p = 0.031$ ), t-test ( $p = 0.000$ ). Smokers are positively correlated with Fe. Actually, 50% of smokers are polishers and they are the only ones having Fe in toenails.

#### 8.4.3. Biomonitor Hair and Toenail from Workers Group

All the hair and toenail elemental concentrations were grouped considering the following elements: Ag, Al, Au, Cl, Cr, Cu, Fe, Mn, Na and Zn.

- Pearson Correlation: weak positive correlations were found for Ag x Cr and Zn x (Al, Au).

PCA results show that the first four principal components explained 68.3% of the total variation and the 10 variables could be condensed into four PCs. The most significant PCs are PC1 (72.3%, Na, Al, Zn and Cr are positively correlated and Fe negatively); PC2 (22.5%, Ag, Cu, Au and Cr are positively correlated); PC3 (13.7%, Cl and Fe are positively correlated and Au negatively) and PC4 (14.8%, Mn, Al, Fe and Zn are positively correlated and Na and Ag, negatively).

- ANOVA and t-test results:
  - Galvanizing*. PC2 ( $p = 0.037$ ). The workers from Galvanizing 3 are positively correlated with Ag and Au, having the highest concentrations.
  - Activity*. PC4 ( $p = 0.010$ ). The officer is positively correlated with Na.
  - Time working in the present activity*. PC2 ( $p = 0.056$ ). The workers who have been working less than 3 years are correlated with Na. These workers are just the officer and the item cleaners, who are not directly dealing with the galvanizing process,
  - Smoking*. PC3 ( $p = 0.011$ ), t-test ( $p = 0.000$ ). The smokers are correlated with Fe and the polishers who smoke are the majority among the smokers.

#### 8.4.4. Biomonitor Hair from Workers and Comparative Group

The hair elemental content from both groups were tested considering the following elements: Al, Au, Br, Cl, Cr, Hg, Na and Zn.

- Pearson Correlation: weak positive correlation was found for Au x Cr.

PCA results show that the first four principal components explained 75.3% of the total variation and the 10 variables could be condensed into four PCs. The most significant PCs are PC1 (24.4%, Cl is positively correlated, and Cr, Au and Al negatively); PC2 (18.3%, Zn, Hg and Na are positively correlated and Cr negatively); PC3 (17.1%, Al and Cl are positively correlated and Na negatively) and PC4 (15.5%, Br and Na are positively correlated and Zn negatively).

- ANOVA and t-test results:
  - PC1 ( $p = 0.001$ ), t-test ( $p = 0.001$ ). The Workers Group is correlated with Cr, Au and Al.

#### 8.4.5. Biomonitor Toenail from Workers and Comparative Groups

The toenail elemental concentrations from both groups were tested considering Au, Cr, Fe and Zn.

- Pearson Correlation: weak positive correlation was found for Au x Cr.

- PCA results show that one principal component explained 47.8% of the total variation and the four variables measured were condensed into one PC, where Au and Cr were positively correlated.
- ANOVA and t –test results:  
PC (p = 0.000), t-test (p = 0.000). The workers samples are correlated with Au and Cr.

#### 8.4.6. *Biomonitors Hair and Toenail from Workers and Comparative Groups*

The hair and toenails elemental concentrations from both groups were tested considering Au, Cr and Zn.

- Pearson Correlation: weak positive correlation was found for Au x (Zn, Cr).
- PCA results show that one principal component explained 64.3% of the total variation and the three variables could be condensed into one PC, where all the elements correlated positively.
- ANOVA and t-test results:  
PC (p = 0.000), t-test (p = 0.000). The workers samples are correlated with the elements presenting the highest concentrations.

## 9. MEDICAL RECOMMENDATIONS

The doctors and the security engineer had already been to the galvanizing factories for a routine inspection, as recommended in the Worker's Health Awareness Program. At that time they prepared a report pointing out various items which did not meet the requirements for the security conditions at work. After examining the results obtained by this project, they verified that the situation found is a consequence of the bad conditions observed during the inspection. The results confirmed and reinforced the need of actions in order to minimise the hazardous work conditions. This first assessment alerts for the need of assessing the influence of a long-term exposure and will support the establishment of guidelines and data basis for the next occupational programme for this specific workplace.

The doctors and the security engineer suggested the following main actions to be executed in all galvanizings: install exhausts over the bath and the polishing areas; close the communications between polishing and bath areas making them independent workplaces; if possible install windows; treat residual water; organize and keep the workplace clean; use of individual security equipment by all workmen; monitor more frequently the concentration of chromium in blood, include the airborne particulate matter analysis in monitoring programme and use the biomonitors hair, nails and urine to verify the level of contamination. The analysis will follow up the efficiency of the changes inside the workplace.

## 10. CONCLUSIONS

This investigation project was the first action in order to assess the elemental concentration level in a galvanizing industry. Many studies have been developed concerning this industrial process involving many aspects including consequences of chromium and nickel

contamination, but so far none included measurement of other elements such as silver, gold, antimony, arsenic.

It was important to carry out the airborne particulate matter sampling. The results showed the high level of pollutants which the workers are exposed to inside the galvanizing factories. The contamination was demonstrated by analysing the biomonitors: hair, toenails and urine. The results obtained confirmed the medical suspicions of workers' contamination and the medical recommendations aimed at minimizing the hazardous condition at the workplace and its effects. The elemental concentrations determined in the workers' hair, toenail and urine samples were higher than in the Comparative Group samples. Besides, the presence of other elements in the workers' samples, not detected in the comparative samples, confirms the contamination. The presence of Br, Na, Hg that are not associated with the industrial processes showed the same level both in the workers' samples and in the Comparative Group samples.

The statistical analysis applying the multivariate, ANOVA and t-test methods were useful although the percentage of population analysed was not ideal. The methods demonstrated that through the measurements of the workers' hair samples it is possible to differentiate the galvanization activities (polishing, plating, cleaning, etc), the influence of the length of time working at a specific activity, and a possible interference of drinking on the level of contamination. Using the toenail workers' samples, it is also possible to differentiate the factory, the activity and the possible influence of smoking. Analysing together hair and toenail workers' matrixes, the results confirm that is possible to differentiate the galvanization activities, the influence of the length of time working at a specific activity, and a possible influence of smoking on contamination, but not the influence of drinking habits.

A comparative analysis of the matrixes of both groups, the hair, the toenails or hair and toenails, proves, through statistical methods, that the two groups are distinct. The presence of chromium and gold confirms this difference. On the other hand, by having solely elemental measurements results and knowing the independent classes and the matrixes analysed, it would be possible to guess about the galvanizing and the galvanization activities.

The  $k_0$ -PNAA demonstrated to be efficient for determining the elemental concentrations in the matrixes except in urine, because of the intrinsic interference of the matrix. However, GFAAS was suitable as a supplement method for this type of samples.

## REFERENCES

- [1] TOMAS, H.E., Química bioinorgânica, Washington, OEA (1984) 105 (monografias, 29).
- [2] SIGEL, H., Concepts on metal ion toxicity, New York, Marcel Dekker, **20** (1986) 386 (Metal ions in biological systems).
- [3] STELLMAN, J.M., DAUM, S.M., Trabalho e saúde na indústria, riscos físicos e químicos e prevenção de acidentes, vol. 1, Editora Pedagógica e Universitária Ltda and Editora da Universidade de São Paulo, São Paulo (1975).
- [4] ALMEIDA, I.M., Dificuldades no diagnóstico de doenças ocupacionais e do trabalho. *Jornal Brasileiro de Medicina* **74**(1/2) (1998) 35–48.

- [5] NR 7 — Programa de controle médico de saúde ocupacional. In: Segurança e medicina do trabalho. 43 ed. São Paulo: Atlas, (Manuais de Legislação Atlas, 16), 655 p. (1999) 86–97.
- [6] AMERICAN CONFERENCE OF GOVERNMENTAL INDUSTRIAL HYGIENISTS, Threshold limit values for chemical substances in the work environment, Cincinnati, ACGIH (2000) 105.
- [7] NAGRA, M.S., PALAH, B.S., SAHOTA, G.P.S., SINGH, H., SAHOTA, H.S., A study of trace elements in scalp hair and fingernails of industrial workers of Ontario, Canada, *J. Radioanal. Nucl. Chem., Articles* **162**(2) (1992) 283–288.
- [8] RYABUKHIN, Y.S., Activation analysis of hair as Na indicator of contamination of man by environmental trace elements pollutants, IAEA/RL/50, Vienna (1978) 132.
- [9] WORLD HEALTH ORGANIZATION, Biological monitoring of chemical exposure in the workplace; guidelines, Geneve, World Health Organization **1** (1996).
- [10] SAIKI, M.; VASCONCELLOS, M.B.A., ARAUZ, L.J.; FULFARO, R., Determination of trace elements in human head hair by neutron activation analysis, *J. Radioanal. Nucl. Chem.* **236**(1-2) (1998) 25–28.
- [11] COLACIOPPO, S., Avaliação da exposição profissional a fumos metálicos em operações de solda, *Revista Brasileira de Saúde Ocupacional*, **13**(49) (Janeiro/Fevereiro/Março 1985) 50–77.
- [12] SILVA, C.S., Um estudo crítico sobre a saúde dos trabalhadores de galvânicas, por meio das relações entre as avaliações ambientais, biológicas e otorrinolaringológicas. São Paulo, FUNDACENTRO, Tese, doutorado, Instituto de Química da Universidade de São Paulo (1998) 196.
- [13] OLIVEIRA, B.F., VILLEGAS, E.A., Perfil das indústrias de galvanoplastias em Belo Horizonte e arredores, Simpósio de Tecnologias Limpas, Minas Alemanha, Belo Horizonte (1997).
- [14] SETTINI, M.M., SANTOS, U.P., MARTARELLO, N.A., UGA, J.L., Trabalho em galvanoplastia: riscos, patologia e prevenção, COSTA, D.F., et al., Programa de saúde dos trabalhadores; a experiência da zona norte uma alternativa em saúde pública. São Paulo, Hucitec (1989) 243–266.
- [15] LAINE, V.I., Modern electroplating, Tradução por Ch. Nisembaum, Jerusalem, Keter Press (1970) 306, Tradução de: Sovremennaya gal'vano-tekhnika.
- [16] JOHNSON, R.A., WICHERN, D.W., Applied multivariate statistical analysis, New Jersey, Prentice-Hall (1992) 642.
- [17] MENEZES, M.Â.B.C., SABINO, C.V.S., AMARAL, A.M., MATTOS, S.V.M., FILHO, S.B.S., MAIA, E.C.P., Galvanizing industry: evaluation of contamination level using biomonitors, Congresso Geral em Energia Nuclear, 7 (General Conference on Nuclear Energy), 31<sup>st</sup> Aug.–3<sup>rd</sup> Sept., 1999, Belo Horizonte, Proceedings Belo Horizonte: Associação Brasileira de Energia Nuclear (Brazilian Association for Nuclear Energy) (1999) CD-ROM.
- [18] MENEZES, M.Â.B.C., SABINO, C.V.S., AMARAL, A.M., MATTOS, S.V.M., FILHO, S.B.S.,  $K_0$ -NAA applied to certified reference materials and hair samples: evaluation of exposure level in a galvanising industry, *Journal of Radioanalytical and Nuclear Chemistry. Conference on Modern Trends in Activation Analysis*, 10, 19–23 April 1999, Bethesda, Proceedings **245**(1) (2000) 173–178.
- [19] INTERNATIONAL ATOMIC ENERGY AGENCY, The Assessment of Levels and Health-effects of Airborne Particulate Matter in Mining, Metal Refining and Metal Working Industries using Nuclear and Related Analytical Techniques, IAEA, Vienna (1997).

- [20] SHANGAI INSTITUTE OF NUCLEAR RESEARCH, Certified of Certified Reference Material GBW 09101 Human Hair (1988).
- [21] KUČERA, J., LENER, J., SOUKAL, L., HORÁKOVÁ, J., Air pollution and biological monitoring of environmental exposure to vanadium using short-time neutron activation analysis, *J. Trace and Microprobe Techniques* **141**(1) (1996) 191–201.
- [22] SABINO, C.V.S., ROSSI, H.M., KASTNER, G.F., FRANCO, M.B., Testes relativos a implantação do método  $k_0$  no reator IPR R1, CDTN/CNEN, CDTN-805/95, Belo Horizonte (1995).
- [23] DE CORTE, F., The  $k_0$  — standardisation method; a move to the optimisation of neutron activation analysis, *Ryksuniversiteit Gent, Faculteit Van de Wetenschappen* (1986) 464.
- [24] L'VOV, B.V., Atomic absorption spectrochemical analysis. London: Adan Hilges (1970).
- [25] SENA, M.M., POPPI, R.J., Avaliação do uso de métodos quimiométricos em análise de solos, *Química Nova* **23**(4) (2000) 547–556.
- [26] CHENG, T. P., MORRIS, J.S., KOIRTYOHANN, S.R., SPATE, V.L., BASKETT, C.K., Study of the correlations of trace elements in carpenters' toenails, *J. Radioanal. Nucl. Chem., Articles* **195**(1) (1995) 31–42.
- [27] GEORGESCU, R., PANTELICA, A., CRACIUN, D., GROSESCU, R., Factorial discriminant analysis of occupational exposure in metallurgy using INAA of hair samples, *J. Radioanal. Nucl. Chem.* **231** (1) (1998) 3–9.
- [28] SYSTAT<sup>®</sup> 7.0 for Windows<sup>®</sup>, Statistics, Chicago, SPSS Inc. (1997).
- [29] INTERNATIONAL ATOMIC ENERGY AGENCY, Coordinated research project on the assessment of levels and health-effects of airborne particulate matter in mining, metal refining and metal working industries using nuclear and related analytical techniques, Belo Horizonte, NAHRES-59 (Report on the Second Research Coordination Meeting) (2000).
- [30] MENEZES, M.Â.B.C., MAIA, E.C.P., NEVES, O.F., BATISTA, J.R.,  $K_0$  — Ativação neutrônica paramétrica: avaliação da contaminação em trabalhadores utilizando o biomonitor cabelo, Encontro de Aplicações nucleares, V, 15 – 20 outubro de 2000, Rio de Janeiro, Anais, Rio de Janeiro, ABEN (2000) (CD-ROM).
- [31] IYENGAR, G.V., KOLLMER, W.E., BOWEN, H.J.M., The elemental composition of human tissues and body fluids, Weinheim, Verlag Chemie (1978) (hair, p. 51–54; nails, p. 83–85; urine, p.124–126)

# **A STUDY ON ENVIRONMENTAL POLLUTION MONITORING AND OCCUPATIONAL HEALTH IN THE CAPITAL IRON AND STEEL COMPANY, BEIJING, CHINA, USING NUCLEAR AND RELATED ANALYTICAL TECHNIQUES**

Zhifang. CHAI<sup>1</sup>, Qinfang QIAN<sup>1</sup>, Xiangqian FENG<sup>1</sup>, Peiquan ZHANG<sup>1</sup>,  
Nianqing LIU<sup>1</sup>, Weiyu FENG<sup>1</sup>, Minxu KUANG<sup>2</sup>, Hongyu WANG<sup>2</sup>,  
Yongzheng ZHANG<sup>2</sup>

<sup>1</sup>Laboratory of Nuclear Analytical Techniques and Institute of High Energy Physics,  
Chinese Academy of Sciences, Beijing, China

<sup>2</sup>General Hospital of the Capital Iron and Steel Company, Beijing, China

## **Abstract**

The atmospheric pollution in some Chinese cities is becoming more and more serious with the industrial development and urbanization in the past decades. The airborne particulate concentration in Beijing, the Capital of China, far exceeds the allowable level set by the Chinese government and by the related international organizations. The main contribution source for the Beijing atmospheric particles is the Capital Iron and Steel Company that constitutes 55% of total airborne particulate in Beijing. In the framework of this Coordinated Research Project organized by IAEA, this company was selected as a target workplace. The instrumental neutron activation analysis, proton induced X ray emission analysis, synchronous radiation X ray fluorescence spectrometry and other related techniques were applied to determine the concentrations of some target elements, such as heavy metals and toxic elements, in environmental samples (including airborne particles, soil and plants) and human samples (including head hair, urine and blood) collected from workers and staff members at this company. In the meantime, a surrounding region and a clean region were selected as control. All the analytical results obtained during this CRP period are presented here with statistical treatment of human health survey. Some significant conclusions and suggestion to alleviate or control the pollution are also outlined as well.

## **1. INTRODUCTION**

The Capital Iron and Steel Company (CISC) is one of the biggest industrial companies in Beijing, China, which contributes more than 55% of the atmospheric particles in the capital city. The environmental pollution, especially heavy metals and toxic elements, caused by this company becomes more and more serious in the workplace and its surrounding regions [1], which is endangering over 100,000 people working there and another 500,000 residents living at its surrounding region. Thus, an overall investigation of trace elements, especially of heavy metals, levels in the environmental materials and in human tissue and fluid samples is highly needed for evaluation of the environmental pollution level in this target area and its impact on occupational health status.

The concentration of airborne particulate matter (APM) in atmosphere and the contents of heavy metals and toxic elements in it can directly reflect the environmental pollution level. In addition, some plants can also be used as bioindicators to monitor environmental pollution status [2]. The contents of pollutants in hair, blood and urine can indicate the level and absorption status of pollutants in human body. Due to its simplicity of sampling, preparation and analysis, the head hair is usually used for monitoring the long-term environmental exposure to pollutants as well as for evaluating toxicological effects caused by heavy metals, because elements are absorbed by hair and retained over a period of time. In other aspect,



blood and urine are suitable for transient environmental exposure monitoring. In this work, airborne particulate matter, plants, soil, human hair, blood and urine were selected to survey the environmental pollution status and occupational health at CISC.

## 2. SAMPLES

### 2.1. Sampling site

The CISC is located in the west of Beijing, which consists of an ironwork shop including 4 iron smelting furnaces, 3 steelworks and other auxiliary works. The environmental pollution is most serious at the smelters. In this study, two of 4 iron smelting furnaces were selected to investigate the environmental pollution, and 25 workers at each iron smelter were chosen to collect hair, blood and urine and for occupational examination of healthy status. As a comparison, 50 rear-service or administrative staff members at CISC were selected to take the same human samples.

Institute of High Energy Physics (IHEP), as a surrounding region located on 5 km east of CISC, was selected to collect APM, plant and soil samples. Meanwhile, 50 scientists or administrative staff members at IHEP without any exposure history were selected to collect hair, blood and urine.

As a non-polluted region, a small town, Xinzhen, located on more than 20 km southeast of CISC was selected. The local residents were selected to take hair, blood and urine.

### 2.2. Environmental samples

Total 13 pairs of air filters (0.4  $\mu\text{m}$  and 8  $\mu\text{m}$  nucleopore films fixed in a GENT Sampler) were used to collect the airborne particulate matter in 3 sampling sites, i.e. 7 pairs at CISC, 2 pairs in its surrounding region and 2 pairs in the Beijing suburb with good air quality. The sampling period in each site was 24 h.

The local plant leaves and soil were also collected. After collection, they were dried at about 50–60°C and stored in a desiccator for further treatment.

### 2.3. Human tissue and fluid samples

In the meantime, the hair, blood and urine from the exposed workers and administration staff members working at CISC and the control group at the surrounding region and non-polluted region were collected according to the recommendation of IAEA. 3 grams of human hair were taken from the occipital part to enable several analyses. Pre-cleaned stainless steel scissors and trimmers were used for collection of specimens and clean paper bags were used for sample storage. The hair samples were washed with acetone and deionized water and air-dried according to the procedure recommended by IAEA for human hair [3]. Before cleaning, hair was cut into about 3 mm long pieces.

Five ml blood and 30 ml urine were simultaneously taken from each person and stored in clean polyethylene vial (acid-washed and cleaned with high purity water). The serum was separated from blood in 5 h after collection of samples and stored at  $-20^{\circ}\text{C}$ . The urine was freeze-dried and stored in refrigerator.

### 3. ANALYTICAL TECHNIQUES

A variety of nuclear and non-nuclear analytical methods were applied, not only for intercomparison of proficiency tests, but also for analysis of real samples. The methods used in this work include INAA, ICP-AES, ICP-MS, AFS, AAS, Scanning-XRF and SRXRF. Table I indicates the application field of the above methods.

TABLE I: ANALYTICAL METHODS AND THEIR APPLICATION WITHIN THIS WORK

Method	Human hair	blood	Urine	APM	Soil	Poplar leaves	Pine leaves
INAA	X			X	X	X	X
Scanning XRF	X			X			
SRXRF	X						
ICP-AES		X	X				
ICP-MS		X	X				
AAS		X	X			X	X
AFS		X(Hg)	X(Hg)				

The experimental details of various methods have been described in our previous reports [4].

## 4. RESULTS AND DISCUSSION

### 4.1. Analytical quality assurance

To assure and control the analytical quality of the analytical methods used in this CRP, the following three measures were taken.

#### 4.1.1. Intercomparison of two or more independent analytical techniques based on different principle

The typical examples include the analysis of NAT-3 urban dust by using INAA and ICP-AES, NAT-7 air loaded filter by INAA and XRF, and determination of mercury in environmental samples by CVAAS and AFS [4].

#### 4.1.2. Use of SRMs

The reference materials used in this CRP include GBW 07601 and 09101 (human hair), IAEA-405 (estuarine sediment) and NIST-1633a (coal fly ash), which can refer to [5].

#### 4.1.3. Proficiency tests

A number of proficiency tests organized by IAEA were performed to examine the analytical quality, including NAT-3 and NAT-7 filters loaded with the Vienna and Prague urban dust, welding fume and lyophilized human urine. The latest proficiency test results on urine are listed in Table II. For the urine analysis, AAS and ICP-AES were applied. Their results are in good agreement. For NAT-7, INAA and scanning XRF were used. Also, the results provided by these two methods agree well. This time the NAT-3 air filter was used as a reference material. As a result, the analytical quality of NAT-7 has been significantly improved in the comparison with the last analysis.

TABLE II: CONCENTRATIONS OF AS, CD, CR AND CO IN LYOPHILIZED URINE PROFICIENCY TEST

Measurand	Unit	Level Low		Level Medium		Level High	
		Sample A	Sample B	Sample A	Sample B	Sample A	Sample B
Arsenic, total (As-t)	µg/L	19.0	18.0	71.9	69.3	150	141
Cadmium (Cd)	µg/L	0.54	0.60	5.30	4.70	12.0	10.1
Chromium (Cr)	µg/L	2.95	3.45	7.42	7.17	19.0	18.3
Cobalt (Co)	µg/L	1.60	1.56	10.5	12.3	63.3	58.1

Note: All 4 elements were determined by both methods: AAS and ICP-AES. Part of them was checked by ICP-MS.

TABLE III: CONTENTS OF TRACE ELEMENTS IN APM (0.4 μm) AT CISC (ng/m<sup>3</sup>)

	0.4 μm (67)	0.4 μm (68)	0.4 μm (69)	0.4 μm (70)	0.4 μm (71)	0.4 μm (73)	AVERAGE
As	12.1±0.9	17.0±0.8	16.8±0.8	24.3±0.8	26.9±0.9	15.2±0.9	18.7±5.7
Au	0.0005±19	0.007±2.6	0.014±1.7	0.0016±11	0.0019±9.3	0.0007±14	0.0012±0.0007
Ba	66.2±7.6	60.1±10.9	58.8±9.3	132±6.4	159±6.5	35.0±12.1	85.2±48.7
Br*	135	112	109	150	242	76	137±57
Ca*	1820	3390	2140	4940	6350	2890	3590±1740
Co	1.42±3.1	1.44±3.6	1.45±3.2	2.10±3.0	2.11±3.2	1.36±3.1	1.65±0.36
Cr	85.0±1.3	112±1.3	79.7±1.4	138±1.3	134±1.4	87.4±1.3	106±26
Cs	1.78±2.9	3.57±2.4	5.73±1.7	4.02±2.4	4.74±2.2	3.23±2.1	3.85±1.35
Cu*	103	178	115	172	200	101	145±43
Fe	2580±2.0	4360±1.8	10700±1.3	5770±1.8	2990±2.5	1180±3.1	4600±3380
Fe*	2450	4590	10930	5340	2880	1210	4570±3450
Hf	0.164±19	0.086±34	<0.11	0.120±30	<0.15	<0.08	0.12±0.04
Hg**	0.528	0.514	0.491	0.720	0.917	0.578	0.625±0.165
K	3040±3.1	4130±2.8	7620±2.0	7350±2.6	9080±2.7	6840±2.2	6340±2290
Mn*	247	269	644	237	—	—	349±197
Pb*	227	324	396	344	633	399	387±136
Rb	18.3±4.4	30.7±4.3	62.9±2.4	45.4±3.3	55.1±3.2	39.7±2.7	42.0±16.2
Sb	10.0±1.2	9.33±1.2	9.07±1.2	10.7±1.2	13.0±1.2	6.57±1.3	9.78±2.11
Sc	0.471±1.9	0.438±2.3	0.340±2.5	0.635±2.1	0.577±2.4	0.195±3.3	0.443±0.160
Se	12.0±3.5	16.4±3.2	16.9±2.9	18.6±3.3	20.1±3.2	6.03±6.1	15.0±5.2
Sr	29.1±25	<53	<50	<61	167±10	<39	98±98
Ta	0.031±35	<0.06	0.023±40	0.061±33	0.026±46	0.005±14	0.029±0.020
Th	0.526±3.9	0.522±4.9	0.416±5.4	0.745±4.1	0.671±4.6	0.214±9.0	517±187
Ti*	—	—	236	—	—	—	—
Zn	425±1.4	1190±1.2	1340±1.1	1320±1.2	1520±1.2	916±1.2	1120±390
Zn*	359	1150	1210	1100	1260	845	987±340
T.C.	135	182	155	212	251	115	165±54

\* Determined by XRF; \*\* Determined by AFS; T.C. Total concentration of air particles

TABLE III: (CONTINUED) CONTENTS OF TRACE ELEMENTS IN APM (8  $\mu\text{m}$ ) AT CISC (ng/m<sup>3</sup>)

	8 $\mu\text{m}$ (80)	8 $\mu\text{m}$ (81)	8 $\mu\text{m}$ (82)	8 $\mu\text{m}$ (83)	8 $\mu\text{m}$ (84)	8 $\mu\text{m}$ (85)	8 $\mu\text{m}$ (86)	AVERAGE
As	16.7 $\pm$ 1.2	13.4 $\pm$ 1.3	12.3 $\pm$ 1.3	13.1 $\pm$ 1.5	15.7 $\pm$ 1.4	5.71 $\pm$ 1.3	9.18 $\pm$ 1.4	12.3 $\pm$ 3.8
Au	0.002 $\pm$ 9.2	0.001 $\pm$ 14	0.003 $\pm$ 6.0	<0.001	0.0003 $\pm$ 8.0	0.0008 $\pm$ 11	0.001 $\pm$ 13	0.0005 $\pm$ 0.0004
Ba	415 $\pm$ 2.9	280 $\pm$ 3.8	504 $\pm$ 2.3	475 $\pm$ 3.5	561 $\pm$ 2.4	242 $\pm$ 2.1	147 $\pm$ 4.1	375 $\pm$ 154
Br*	158	279	282	315	234		140	235 $\pm$ 71
Ca*	2600	5980	6830	5830	21500		11000	12900 $\pm$ 8760
Co	6.05 $\pm$ 1.6	4.36 $\pm$ 1.8	4.53 $\pm$ 1.7	2.60 $\pm$ 2.5	2.45 $\pm$ 2.9	2.36 $\pm$ 1.5	1.71 $\pm$ 2.5	3.44 $\pm$ 1.56
Cr	121 $\pm$ 1.3	89.2 $\pm$ 1.4	75.2 $\pm$ 1.5	117 $\pm$ 1.7	137 $\pm$ 1.3	36.0 $\pm$ 1.3	70.1 $\pm$ 1.4	92.2 $\pm$ 35.1
Cs	3.48 $\pm$ 2.5	2.48 $\pm$ 3.1	5.15 $\pm$ 1.9	1.27 $\pm$ 5.3	1.45 $\pm$ 4.6	1.27 $\pm$ 2.4	0.899 $\pm$ 4.2	2.29 $\pm$ 1.55
Cu*	105	127	92	132	145		121	120 $\pm$ 19
Fe	17000 $\pm$ 1.2	14200 $\pm$ 1.3	30800 $\pm$ 1.1	8520 $\pm$ 1.6	7670 $\pm$ 1.7	5950 $\pm$ 1.2	4630 $\pm$ 1.7	12700 $\pm$ 9100
Fe*	1100	13700	28800	8630	7550		4290	10700 $\pm$ 9840
Hf	1.63 $\pm$ 3.8	1.10 $\pm$ 5.0	0.80 $\pm$ 6.1	0.41 $\pm$ 16	0.50 $\pm$ 10	0.56 $\pm$ 3.5	0.42 $\pm$ 7.7	0.77 $\pm$ 0.45
Hg**	0.553	0.706	0.648	0.768	0.961		0.582	0.703 $\pm$ 0.149
K	6960 $\pm$ 3.8	4550 $\pm$ 4.9	7950 $\pm$ 3.0	2660 $\pm$ 9.3	3150 $\pm$ 7.9	2570 $\pm$ 4.1	2350 $\pm$ 8.8	4310 $\pm$ 2280
Mn*	519	313	661	241	217		69.9	337 $\pm$ 216
Pb*	252	179	279	137	271		144	210 $\pm$ 65
Rb	46.2 $\pm$ 3.4	28.0 $\pm$ 5.2	62.1 $\pm$ 2.8	15.7 $\pm$ 7.9	17.8 $\pm$ 6.4	15.4 $\pm$ 3.3	10.2 $\pm$ 7.0	27.9 $\pm$ 19.3
Sb	11.9 $\pm$ 1.2	4.87 $\pm$ 1.6	7.06 $\pm$ 1.4	2.48 $\pm$ 2.8	2.98 $\pm$ 2.2	4.17 $\pm$ 1.2	2.15 $\pm$ 2.0	5.09 $\pm$ 3.44
Sc	4.31 $\pm$ 1.1	3.12 $\pm$ 1.2	2.69 $\pm$ 1.2	1.77 $\pm$ 1.3	1.70 $\pm$ 1.4	1.43 $\pm$ 1.1	1.05 $\pm$ 1.4	2.30 $\pm$ 1.14
Se	11.4 $\pm$ 4.7	9.30 $\pm$ 5.1	12.5 $\pm$ 4.0	3.55 $\pm$ 28	5.31 $\pm$ 8.9	2.67 $\pm$ 7.0	1.79 $\pm$ 12	6.65 $\pm$ 4.37
Sr	193 $\pm$ 8.8	207 $\pm$ 8.4	181 $\pm$ 9.4	162 $\pm$ 13.4	153 $\pm$ 10	78.3 $\pm$ 7.1	60.7 $\pm$ 12	148 $\pm$ 57
Ta	0.27 $\pm$ 8.8	0.19 $\pm$ 12	0.21 $\pm$ 22	0.10 $\pm$ 18	0.07 $\pm$ 26	0.10 $\pm$ 7.3	0.07 $\pm$ 17	0.14 $\pm$ 0.08
Th	4.97 $\pm$ 1.4	3.66 $\pm$ 1.5	2.86 $\pm$ 1.7	1.92 $\pm$ 3.0	1.83 $\pm$ 2.2	1.55 $\pm$ 1.4	1.12 $\pm$ 2.1	2.56 $\pm$ 1.36
Ti*	717	—	—	—	442		—	—
Zn	504 $\pm$ 1.4	571 $\pm$ 1.4	1180 $\pm$ 1.2	443 $\pm$ 1.5	472 $\pm$ 1.6	441 $\pm$ 1.1	270 $\pm$ 1.6	554 $\pm$ 290
Zn*	423	543	918	434	476		244	506 $\pm$ 225
T.C.	266	279	352	212	220	155	128	230 $\pm$ 76

\* Determined by XRF; \*\* Determined by AFS; T.C. Total concentration of air particles

## 4.2. Environmental sample analysis

### 4.2.1. Airborne particulate matter

Each piece of filter loaded with atmospheric particles was evenly cut into 4 sub-pieces by a Ti knife. One for scanning XRF analysis; one for Hg determination by AFS and the other two for INAA. The results for CISC, IHEP and Xinzhen are listed in Tables III-V, respectively. Comparing the data in these Tables, the following conclusions can be drawn:

1. The results provided by INAA and scanning XRF are comparable, e.g. contents of Fe and Zn in APM.
2. As, Se, Sb, Pb, Au, K, Rb and Cs are enriched in fine particles, whereas Ca, Sr, Ba, Sc, Th, Ta, Co, Fe and Hf in coarse particles. As to Cr, Cu, Hg and Mn, the ratios of their contents in fine over coarse particles are close to 1. It implies that they have different sources.
3. The total concentration of atmospheric particles at CISC is much higher than the control areas, especially the concentration of fine particles. It is about 8 times higher at CISC for 0.4  $\mu\text{m}$  particle fraction, while only less than 2 for 8  $\mu\text{m}$ . It means that the iron and steel smelters mainly produce the fine particles.
4. Among the elements determined in this work, the contents of Fe and Mn in APM at CISC are much higher than those in the control areas, which may be attributed to the iron ores, one of major raw materials for iron and steel production, containing high content of Fe and Mn.
5. The statistical treatment of the results in Tables III-V indicates that there is significant difference between the contents of Hg and Pb at CISC and the control areas, which implies that Hg and Pb at different areas come from different original source(s). In the surrounding soil and plant samples the similar distribution patterns appear (see next section). One possible interpretation is that at CISC Hg mainly comes from coal burning, where tons of coal are burnt daily. As a result, it contributes most of Hg in coal released into atmosphere. As to the high content of Pb in APM at CISC, it is likely attributed to the vehicles' exhaust gas, because the local traffic was very heavy.
6. The contents of most trace elements, especially Fe, Co, Cr and Cu, etc. in APM at IHEP are higher than at IAE. The reason is likely that IHEP is located near to CISC. However, the contents of Pb, Zn and Ca, etc. exhibits the contrary pattern, because the traffic is heavy at IAE and there is a construction site near it.

TABLE IV: CONTENTS OF TRACE ELEMENTS IN APM (0.4  $\mu\text{m}$  AND 8  $\mu\text{m}$ ) AT INSTITUTE OF HIGH ENERGY PHYSICS ( $\text{ng}/\text{m}^3$ )

	0.4 $\mu\text{m}$ (61)	0.4 $\mu\text{m}$ (62)	Average	8 $\mu\text{m}$ (74)	8 $\mu\text{m}$ (75)	AVERAGE
As	2.93 $\pm$ 0.8	2.44 $\pm$ 0.8	2.69 $\pm$ 0.35	6.73 $\pm$ 1.7	10.8 $\pm$ 0.5	8.77 $\pm$ 2.88
Au	0.0002 $\pm$ 13	0.0001 $\pm$ 23	0.0002 $\pm$ 0.0001	0.0004 $\pm$ 24	0.0004 $\pm$ 11	0.0004 $\pm$ 0.0001
Ba	17.0 $\pm$ 7.6	11.8 $\pm$ 20	14.4 $\pm$ 3.7	185 $\pm$ 3.2	134 $\pm$ 2.5	160 $\pm$ 36
Br*	41.4	34.9	38.2	40.3	21.7	31.0 $\pm$ 13.2
Ca*	465	—	465	9140	8180	8660 $\pm$ 680
Co	0.590 $\pm$ 2.3	0.515 $\pm$ 2.3	553 $\pm$ 53	3.23 $\pm$ 1.2	3.41 $\pm$ 1.1	3.32 $\pm$ 0.13
Cr	21.8 $\pm$ 1.3	22.2 $\pm$ 1.5	22.0 $\pm$ 0.28	29.9 $\pm$ 1.9	29.6 $\pm$ 1.3	29.8 $\pm$ 0.2
Cs	0.183 $\pm$ 5.4	0.204 $\pm$ 5.0	0.194 $\pm$ 0.015	0.836 $\pm$ 3.1	0.905 $\pm$ 2.7	0.871 $\pm$ 0.049
Cu*	28.6	30.0	29.5	26.1	20.5	23.3 $\pm$ 4.0
Fe	512 $\pm$ 2.4	416 $\pm$ 3.4	464 $\pm$ 68	5390 $\pm$ 1.2	4940 $\pm$ 1.2	5170 $\pm$ 320
Fe*	510	387	449 $\pm$ 87	4830	4780	4810 $\pm$ 40
Hf	0.066 $\pm$ 13	<0.07	<0.07	<0.14	0.666 $\pm$ 2.8	<0.14
Hg**	0.060	0.054	0.057 $\pm$ 0.004	0.094	0.086	0.090 $\pm$ 0.006
K	365 $\pm$ 4.9	352 $\pm$ 4.2	359 $\pm$ 9	2210 $\pm$ 8.4	1820 $\pm$ 3.4	2020 $\pm$ 280
K*	641	334	488 $\pm$ 217	1920	2170	2050 $\pm$ 180
Mn*	—	—	—	122	119	121 $\pm$ 2
Pb*	32.9	29.3	31.1	49.4	39.4	44.4 $\pm$ 7.1
Rb	1.76 $\pm$ 9.3	2.05 $\pm$ 8.4	1.91 $\pm$ 0.21	12.1 $\pm$ 3.5	11.5 $\pm$ 3.2	11.8 $\pm$ 0.4
Sb	1.46 $\pm$ 1.2	0.96 $\pm$ 1.4	1.21 $\pm$ 0.35	2.05 $\pm$ 1.6	2.04 $\pm$ 1.3	2.05 $\pm$ 0.01
Sc	0.170 $\pm$ 1.6	0.141 $\pm$ 1.7	0.156 $\pm$ 0.021	2.05 $\pm$ 1.1	2.06 $\pm$ 1.1	2.06 $\pm$ 0.01
Se	1.07 $\pm$ 8.0	0.90 $\pm$ 20	0.99 $\pm$ 0.12	<1.3	1.63 $\pm$ 7.9	<1.7
Sr	8.32 $\pm$ 24	<15	<15	46.8 $\pm$ 20	75.3 $\pm$ 6.8	61.1 $\pm$ 20.2
Ta	0.010 $\pm$ 34	0.011 $\pm$ 29	0.011 $\pm$ 0.001	0.112 $\pm$ 6.8	0.126 $\pm$ 6.3	0.119 $\pm$ 0.010
Th	0.164 $\pm$ 3.1	0.125 $\pm$ 7.9	0.145 $\pm$ 0.028	1.83 $\pm$ 1.7	1.82 $\pm$ 1.3	1.83 $\pm$ 0.01
Ti*	—	—	—	394	668	531 $\pm$ 194
Zn	70.8 $\pm$ 1.7	72.9 $\pm$ 1.6	71.9 $\pm$ 1.5	166 $\pm$ 1.3	97.6 $\pm$ 1.5	132 $\pm$ 48
Zn*	61.1	62.8	62.0	129	75.4	102 $\pm$ 38
<u>T.C.</u>	24	17	21 $\pm$ 5	147	136	142 $\pm$ 8

\* Determined by XRF; \*\* Determined by AFS; T.C. Total concentration of airborne particles

TABLE V: CONTENTS OF TRACE ELEMENTS IN AIR PARTICLES (0.4  $\mu\text{m}$  AND 8  $\mu\text{m}$ ) AT THE SUBURB OF BEIJING (INSTITUTE OF ATOMIC ENERGY) ( $\text{ng}/\text{m}^3$ )

	0.4 $\mu\text{m}$ (65)	0.4 $\mu\text{m}$ (66)	Average	8 $\mu\text{m}$ (78)	8 $\mu\text{m}$ (79)	Average
As	1.84 $\pm$ 0.9	3.18 $\pm$ 1.0	2.51 $\pm$ 0.95	7.55 $\pm$ 0.6	6.11 $\pm$ 0.8	6.83 $\pm$ 1.02
Au	0.0001 $\pm$ 24	0.0003 $\pm$ 13	0.0002 $\pm$ 0.0001	0.0006 $\pm$ 7.6	0.0009 $\pm$ 11	0.0008 $\pm$ 0.0002
Ba	8.98 $\pm$ 9.9	10.4 $\pm$ 15	9.69 $\pm$ 1.00	75.0 $\pm$ 3.0	123 $\pm$ 3.5	99 $\pm$ 34
Br*	22.2	19.8	21.0 $\pm$ 1.7	26.4	52.2	39.3 $\pm$ 18.2
Ca*	—	2250	2250	12300	24300	18300 $\pm$ 8500
Co	0.279 $\pm$ 3.1	0.306 $\pm$ 3.8	0.293 $\pm$ 0.019	1.79 $\pm$ 1.3	2.53 $\pm$ 1.4	2.16 $\pm$ 0.52
Cr	12.3 $\pm$ 1.5	19.8 $\pm$ 1.5	16.1 $\pm$ 5.3	18.0 $\pm$ 1.5	26.0 $\pm$ 1.7	22.0 $\pm$ 5.7
Cs	0.842 $\pm$ 1.8	2.82 $\pm$ 1.4	1.83 $\pm$ 1.40	4.53 $\pm$ 1.2	7.00 $\pm$ 1.2	5.77 $\pm$ 1.75
Cu*	19.7	21.1	20.4 $\pm$ 1.0	18.2	23.5	20.9 $\pm$ 3.7
Fe	250 $\pm$ 3.1	340 $\pm$ 3.3	295 $\pm$ 64	2990 $\pm$ 1.2	5050 $\pm$ 1.2	4020 $\pm$ 1460
Fe*	216	449	333 $\pm$ 165	2450	4570	3510 $\pm$ 1500
Hf	<0.02	<0.03	<0.03	0.332 $\pm$ 3.7	0.422 $\pm$ 4.8	0.377 $\pm$ 0.064
Hg**	0.096	0.114	0.105 $\pm$ 0.013	0.111	0.317	0.214 $\pm$ 0.146
K	1090 $\pm$ 2.0	4730 $\pm$ 1.4	2910 $\pm$ 2570	6760 $\pm$ 1.4	11100 $\pm$ 1.5	8930 $\pm$ 3070
K*	344	4850	2600 $\pm$ 3190	5400	12800	9100 $\pm$ 5200
Mn*	—	—	—	55.9	107	81.5 $\pm$ 36.1
Pb*	24.9	78.3	51.6 $\pm$ 37.8	52.6	208	130 $\pm$ 110
Rb	7.26 $\pm$ 2.9	31.7 $\pm$ 1.8	19.5 $\pm$ 17.3	45.5 $\pm$ 1.5	75.1 $\pm$ 1.5	60.3 $\pm$ 20.9
Sb	1.28 $\pm$ 1.2	0.872 $\pm$ 1.6	1.08 $\pm$ 0.29	2.25 $\pm$ 1.2	3.56 $\pm$ 1.3	2.91 $\pm$ 0.93
Sc	0.079 $\pm$ 2.0	0.078 $\pm$ 2.5	0.079 $\pm$ 0.001	1.15 $\pm$ 1.1	1.45 $\pm$ 1.1	1.30 $\pm$ 0.21
Se	0.806 $\pm$ 20	1.10 $\pm$ 9.7	0.95 $\pm$ 0.21	1.65 $\pm$ 6.3	2.94 $\pm$ 8.8	2.30 $\pm$ 0.91
Sr	<6.8	<13	<13	57.5 $\pm$ 7.1	57.0 $\pm$ 11	57.3 $\pm$ 0.4
Ta	0.004 $\pm$ 50	0.004 $\pm$ 45	0.004 $\pm$ 0.001	0.074 $\pm$ 8.2	0.106 $\pm$ 10	0.090 $\pm$ 0.023
Th	0.067 $\pm$ 5.0	0.102 $\pm$ 5.8	0.085 $\pm$ 0.025	1.12 $\pm$ 1.4	1.31 $\pm$ 1.7	1.22 $\pm$ 0.13
Ti*	—	—	—	229	433	331 $\pm$ 144
Zn	42.5 $\pm$ 1.7	283 $\pm$ 1.2	163 $\pm$ 170	132 $\pm$ 1.3	1260 $\pm$ 1.1	696 $\pm$ 798
Zn**	42.9	293	168 $\pm$ 177	100	1060	580 $\pm$ 680
<u>T.C.</u>	18	39	29 $\pm$ 15	114	147	131 $\pm$ 23

\* Determined by XRF; \*\* Determined by AFS; T.C. Total concentration of airborne particles



#### 4.2.2. Pine needle and poplar leaves

The contents of trace elements in pine needles and poplar leaves at CISC, IAEA and IAE determined by INAA are listed in Tables VI and VII. The following conclusions can be drawn from the data:

1. Iron is highly enriched in pine needle and poplar leaves at CISC, which means that the pollution of iron is very serious there. The contents of Fe in the washed pine needle and poplar leaves at CISC are about 10 and 4 times higher than at IHEP and IAE, respectively. As to the non-washed samples, even 20 and 8 times higher. Ni, Co, and V exhibit the similar patterns, although their enrichment factors are not so high as Fe at CISC.

2. Interestingly, the contents of Zn, Cu, Cr and Cd at CISC are comparable with those at IHEP and IAE, which implies that they have a general pollution source, regardless of the presence of CISC.

#### 4.2.3. Soil

The contents of trace elements in soil at CISC, IHEP and IAE are listed in Table VIII. The most enriched element in the soil samples at CISC is iron, followed by Zn and Pb. As to Cu, Cr, Ni, Cd, Co and V, their contents in the CISC soil are close to those at IHEP and IAE. It is likely due to their different pollution sources.

TABLE VI: CONTENTS OF TRACE ELEMENTS IN PINE NEEDLES DETERMINED BY INAA (mg/kg)

		Cu	Zn	Fe	Cr	Ni	Cd	Pb	Co	V
CISC	Wash	2.38	13.9	2156	0.50	0.66	0.11	6.50	0.48	0.72
		2.36	14.8	2151	0.53	0.82	0.12	6.05	0.48	0.76
	Average	2.37	14.4	2154	0.52	0.74	0.12	6.28	0.48	0.74
	w. wash	3.82	25.8	7890	2.60	0.86	0.19	11.53	0.64	2.17
		3.46	23.7	7318	1.83	1.27	0.19	12.05	0.54	2.79
	Average	3.64	24.8	7604	2.22	1.07	0.19	11.79	0.59	2.48
near CISC	Wash	2.17	35.7	517.8	0.58	0.36	0.14	5.90	0.19	0.20
		2.39	38.9	508.4	0.63	0.33	0.18	5.30	0.30	0.15
	Average	2.28	37.3	513.1	0.61	0.35	0.16	5.6	0.25	0.175
	w. wash	2.70	32.1	997.2	0.48	0.41	0.30	5.92	0.42	0.31
		2.85	31.7	900.4	0.43	0.60	0.32	5.40	0.54	0.29
	Average	2.78	31.90	948.8	0.46	0.51	0.31	5.66	0.48	0.30
IHEP	Wash	2.24	33.7	220.6	0.74	0.24	0.032	3.42	0.18	0.21
		2.51	36.5	213.9	0.67	0.32	0.015	3.50	0.30	0.45
	Average	2.37	35.1	217.3	0.71	0.28	0.024	3.46	0.24	0.33
	w. wash	2.04	34.8	280.4	0.68	0.90	0.10	5.45	0.42	0.51
		5.07	36.7	312.9	0.83	0.74	0.12	8.00	0.30	0.60
	Average	3.56	35.8	296.7	0.76	0.82	0.11	6.73	0.36	0.56
IAE	Wash	2.16	31.5	284.0	0.82	0.37	0.16	5.07	0.42	0.17
		2.30	20.7	312.9	0.59	0.33	0.11	4.55	0.30	0.40
	Average	2.23	26.1	298.5	0.71	0.35	0.14	4.81	0.36	0.29
	w. wash	2.50	46.1	354.3	1.08	0.37	0.15	4.07	0.27	0.53
		1.83	35.8	321.6	0.84	0.29	0.11	4.42	0.30	0.34
	Average	2.17	41.0	338.0	0.96	0.33	0.13	4.25	0.29	0.44

w.wash: without wash

TABLE VII: CONTENTS OF TRACE ELEMENTS IN POPLAR LEAVES DETERMINED BY INAA (mg/kg)

		Cu	Zn	Fe	Cr	Ni	Cd	Pb	Co	V	
CISC	wash	4.92	20.5	902.0	0.90	0.74	0.24	2.95	0.36	0.46	
		4.34	22.2	908.5	0.59	0.82	0.18	2.12	0.30	0.40	
	average	4.63	21.4	905.3	0.75	0.78	0.21	2.54	0.33	0.43	
	w. wash	5.29	33.3	2716	1.64	1.38	0.45	4.34	0.95	0.83	
5.93		35.7	2951	1.98	1.38	0.41	4.42	1.07	0.86		
near CISC	average	5.61	34.5	2834	1.81	1.38	0.43	4.38	1.01	0.85	
		wash	4.91	17.7	472.1	1.34	0.57	0.11	1.80	0.52	0.54
	w. wash	5.09	20.9	501.0	1.62	0.53	0.13	1.35	0.55	0.48	
		average	5.00	19.30	486.6	1.48	0.55	0.12	1.58	0.54	0.51
IHEP	w. wash	5.44	24.8	1346	2.88	2.02	0.44	2.10	1.43	1.30	
		average	5.63	28.0	1496	3.29	2.27	0.55	3.30	1.46	1.39
	wash	5.54	26.4	1421	3.09	2.15	0.50	2.70	1.45	1.35	
		4.65	22.4	249.4	0.71	0.79	0.45	1.58	0.37	1.09	
	average	4.78	18.9	241.6	0.94	1.07	0.63	1.50	0.55	0.83	
		4.72	20.7	245.5	0.83	0.93	0.54	1.54	0.46	0.96	
	IAE	w. wash	5.73	27.7	423.3	2.03	1.81	0.72	4.57	1.68	2.21
			6.52	28.8	582.9	1.65	1.37	0.66	4.58	1.53	2.42
average		6.13	28.3	503.1	1.84	1.59	0.69	4.58	1.61	2.32	
wash		3.84	15.2	207.7	1.73	1.65	0.41	1.90	1.16	0.41	
	4.69	16.5	245.6	1.91	1.98	0.51	2.50	1.00	0.39		
IAE	average	4.27	15.9	226.7	1.82	1.82	0.46	2.20	1.08	0.40	
		w. wash	4.54	18.3	316.5	1.85	1.99	0.39	4.43	0.83	0.26
	average	4.49	15.6	303.8	1.62	1.68	0.29	5.33	0.92	0.40	
		4.52	17.0	310.2	1.74	1.84	0.34	4.88	0.88	0.33	

TABLE VIII: CONTENTS OF TRACE ELEMENTS IN SOIL DETERMINED BY INAA (mg/kg)

		Cu	Zn	Fe	Cr	Ni	Cd	Pb	Co	V
CISC	surface	27.2	174.8	89329	66.5	32.6	0.40	38.2	9.7	81.8
		29.2	162.7	88975	65.6	30.8	0.33	43.4	11.1	78.8
	average	28.2	168.8	89152	66.1	31.7	0.37	40.8	10.4	80.3
near CISC	surface	42.4	240.5	65192	92.4	40.6	0.39	58.5	13.8	97.9
		41.9	260.3	66423	99.7	39.9	0.44	65.4	15.2	102.9
	average	42.2	250.4	65808	96.1	40.3	0.4	62.0	14.5	100.4
IHEP	surface	22.7	122.5	29723	62.4	32.6	0.33	31.0	10.7	92.8
		22.0	132.8	30182	68.8	31.4	0.34	38.9	9.8	93.2
	average	22.4	127.7	29953	65.6	32.0	0.34	35.0	10.3	93.0
	5-7cm	19.5	103.5	30317	68.1	31.0	—	37.6	10.7	102.5
		20.0	109.9	29770	72.9	29.8	—	34.3	11.9	95.7
average	19.8	106.7	30044	70.5	30.4	—	36.0	11.3	99.1	
IAE	surface	23.5	99.7	33881	70.0	34.5	0.25	29.2	11.6	99.5
		23.0	103.7	34957	69.5	32.0	0.17	31.5	13.5	105.7
	average	23.3	101.7	34419	69.8	33.3	0.2	30.4	12.6	102.6

### 4.3. Biological sample analysis

#### 4.3.1. Human serum

The analysis of ultra trace elements in human serum constitutes a real challenge to analysts. Tables IX and X list the average values determined for 9 elements (Cd, Co, Cr, Cu, Fe, Ni, Pb, V and Zn) in the serum samples of exposed workers (28) and administration staff members (26) working at CISC, along with their ranges in the world [6].

The concentration of iron, the main pollution element at CISC, in the workers' serum is much higher than the world range by a factor of 6–7, also higher than that in the staff members, which clearly indicates that the workers were severely exposed to a large amount of iron powder, dust and vapor.

The concentration range of chromium in the CISC workers' serum is from 0.0011 to 0.0090 mg/L with the average of  $0.00227 + 0.00182$  mg/L, while in the staff member's serum from 0.0028 to 0.00505 with the average of  $0.00174 + 0.00125$  mg/L. Both are much higher than the world range of 0.0001–0.0002 mg/L. Cd, Co, Cu, Ni, Pb and Zn show the similar enrichment patterns. As to vanadium, it is not comparable, due to the lack of the world range.

#### 4.3.2. Human urine

The average concentrations of 9 elements (Cd, Co, Cr, Cu, Fe, Ni, Pb, V and Zn) in human urine samples are listed in Table XI for the workers and in Table XII for the staff members at CISC (29), along with the reference values [6]. Similar to serum, the urine iron concentration in the workers is also higher than that in the staff members. Further, both are much higher than the reference value, due to their exposure to Fe-polluted environment. In addition, Cd, Co, Cr, Ni, V and Zn are more concentrated in the workers' urine than in the staff members. As to Cu and V, their concentrations in two groups are very close, which implies that they have different source.

#### 4.3.3. Human hair

All 140 human hair samples were analysed by INAA and the summary results are listed in Table XIII for the workers (50), in Table XIV for the staff members (53), and in Table XV for the control group (37). The t-test conclusion of the element contents in the hair samples refers to our previous report [4]. It can be concluded that the significant difference exists between the workers at CISC and the control group for several essential trace elements in the hair samples, such as Co, Cr, Fe and Zn, etc. According to the Bertrand's Rule, any element will be harmful to human health when its concentration does not fit the optimal dose window. In next section, the health impact of these elements will be outlined.

From Tables XIII-XV it can be seen that the content of Fe in the workers' hair is much higher than that in the staff members and the controls by a factor of about 3 and 10, respectively. It demonstrates that the working environment at CISC is severely polluted by iron.

In addition, the contents of Ca, Co, Cr, Mg, Mn, V and Zn in the workers' hair are also higher than those in the staff members and controls. However, the contents of As, Br, S, Sb and Se are close for these three human groups, which implies that they have different sources.

TABLE IX: CONCENTRATION OF TRACE ELEMENTS IN SERUM OF WORKERS AT CISC ( $\mu\text{g/mL}$ )

Element	Cd	Co	Cr	Cu	Fe	Ni	Pb	V	Zn
Average	0.0090	0.0135	0.00227	0.721	5.19	0.0216	0.179	0.0135	1.424
SD	0.0060	0.0100	0.0182	0.137	2.25	0.0217	0.110	0.0087	0.392
Range in the world	0.0001-0.002	0.0001-0.0003	0.0001-0.0002	0.8-1.1	0.8-1.2	0.001-0.002	<0.001	—	0.8-1.0

TABLE X: CONCENTRATION OF TRACE ELEMENT IN SERUM OF STAFF MEMBERS AT CISC ( $\mu\text{g/mL}$ )

Element	Cd	Co	Cr	Cu	Fe	Ni	Pb	V	Zn
Average	0.0071	0.0094	0.00174	0.736	5.626	0.0127	0.138	0.0103	1.618
SD	0.0034	0.0063	0.0125	0.096	2.989	0.0051	0.114	0.0048	0.412
Range in the world	0.0001-0.002	0.0001-0.0003	0.0001-0.0002	0.8-1.1	0.8-1.2	0.001-0.002	<0.001	—	0.8-1.0

TABLE XI: CONCENTRATION OF TRACE ELEMENTS IN URINE OF WORKERS AT CISC ( $\mu\text{g/mL}$ )

Element	Cd	Co	Cr (AAS)	Cu	Fe	Ni	Pb	V	Zn
Average	0.0039	0.0069	0.0014	0.011	0.062	0.013	0.080	0.0061	0.794
SD	0.002	0.005	0.001	0.006	0.097	0.008	0.042	0.004	0.424
Range in the world	<0.001	<0.001	0.0002-0.0005	0.03-0.06	0.1-0.15	—	—	—	0.4-0.6

TABLE XII: CONCENTRATION OF TRACE ELEMENTS IN URINE OF STAFF MEMBERS AT CISC ( $\mu\text{g/mL}$ )

Element	Cd	Co	Cr (AAS)	Cu	Fe	Ni	Pb	V	Zn
Average	0.0035	0.0066	0.0011	0.011	0.049	0.012	0.080	0.0039	0.704
SD	0.0023	0.0038	0.0005	0.013	0.066	0.007	0.045	0.0018	0.510
Range in the world	<0.001	<0.001	0.0002-0.0005	0.03-0.06	0.1-0.15	—	—	—	0.4-0.6

TABLE XIII: CONTENTS OF TRACE ELEMENTS IN HAIR OF WORKERS AT CISC

El.	Al	As	Au	Br	Ca	Cl	Co	Cr	Cu	Fe	I	La	Mg	Mn	Na	S	Se	Sb	Sc	Ti	V	Zn
mg/kg	$\mu\text{g/kg}$	$\mu\text{g/kg}$	$\mu\text{g/kg}$	mg/kg	mg/kg	mg/kg	$\mu\text{g/kg}$	mg/kg	mg/kg	mg/kg	mg/kg	$\mu\text{g/kg}$	mg/kg	mg/kg	mg/kg	%	mg/kg	$\mu\text{g/kg}$	$\mu\text{g/kg}$	mg/kg	mg/kg	mg/kg
Average	15.6	103.3	7.74	0.954	1889	474	63.3	0.87	15.1	276.4	0.510	61.4	219	1.893	31.6	4.38	0.648	40.2	7.17	3.22	0.2031	163
SD	5.7	60.44	11.6	0.926	1072	508	18.1	0.43	12.0	325.5	0.373	26.8	111	0.852	19.8	0.32	0.156	12.1	2.77	1.34	0.2269	41

Table XIV: CONTENTS OF TRACE ELEMENTS IN HAIR OF STAFF MEMBERS AT CISC

El.	Al	As	Au	Br	Ca	Cl	Co	Cr	Cu	Fe	I	La	Mg	Mn	Na	S	Se	Sb	Sc	Ti	V	Zn
mg/kg	$\mu\text{g/kg}$	$\mu\text{g/kg}$	$\mu\text{g/kg}$	mg/kg	mg/kg	mg/kg	$\mu\text{g/kg}$	mg/kg	mg/kg	mg/kg	mg/kg	$\mu\text{g/kg}$	mg/kg	mg/kg	mg/kg	%	mg/kg	$\mu\text{g/kg}$	$\mu\text{g/kg}$	mg/kg	mg/kg	mg/kg
Average	18	170	9.76	0.899	1113	761	49.4	0.76	22.6	99.3	0.490	70.7	164	1.34	41.2	4.44	0.542	50.5	6.2	3.51	0.0732	138
SD	19.3	140	8.26	0.390	604	544	11.7	0.52	26.5	66.9	0.292	44.2	69	0.73	22.7	0.33	0.106	17.0	3.9	2.02	0.0237	36

TABLE XV: CONTENTS OF TRACE ELEMENTS IN HAIR OF THE CONTROL GROUP (mg/kg)

El.	As	Au	Br	Ca (%)	Co	Cr	Fe	La	Sb	Se	Zn
Average	0.096	0.005	1.029	0.107	0.015	0.380	21	0.014	0.054	0.452	138
SD	0.042	0.002	0.531	0.054	0.007	0.148	4	0.004	0.040	0.100	27

## 5. MEDICAL EXAMINATION RESULTS OF WORKERS AT CISC

To assess the impact of atmospheric pollution caused by iron and steel smelters at CISC on the worker health, a medical examination survey at CISC for 58 workers and 28 administration staff members were performed, along with 29 persons at IHEP as the control. The statistical results are listed in Table XVI. It can be seen from the results that the exposed workers suffer some clinical symptoms, such as high blood pressure, hypoglycemia, pharynx irritation, pharynx itching and abnormal mucus with higher probability than the controls at IHEP. Thus, the health impact caused by the atmospheric pollution is evident. It should be more serious because the workers at CISC are quite young and very strong in comparison with the persons at IHEP. Of course, it needs a larger database for drawing a medical examination conclusion with the statistical significance.

## 6. SOME SUGGESTIONS FOR IMPROVING THE WORKING CONDITIONS AND ALLEVIATING THE ATOMOSPHERIC POLLUTION CAUSED BY CISC

Several suggestions for the Capital Iron and Steel Company to control the atmospheric pollution and to improve the working condition are proposed as follows:

- a. Reduce working time of workers from 6 h to 5 h per diem.
- b. Reduce working age from the previous 55 years old to present 45.
- c. Increase the pension income.
- d. Increase the medical examination frequency from once per year to once per 6 months.
- e. Strengthen the monitoring of atmospheric quality at CISC and the surrounding area.
- f. Improve the technology to reduce the released amount of pollutants.

Recently, a new measure for completely removing the atmospheric pollution caused by CISC is being implemented by the Beijing Municipal Government, i.e. the whole CISC will be moved from Beijing to other province. It means that the atmospheric quality of the Beijing city will be substantially improved in near future.

TABLE XVI: STATISTICAL RESULTS OF HEALTH IMPACT SURVEY AT CISC AND IHEP

	Workers at CISC (58)	Administration at CISC (29)	IHEP (29)
High blood pressure	19	7	3
Hypoglycemia	7	1	1
Eye itching	7	10	7
Nasal itching	11	10	7
Aqueous nasal discharge	11	10	7
Abnormal mucous	6	3	2
Pharynx itching	17	12	8
Pharynx irritation	17	4	5
Cough	12	9	7
Sputum	1	10	5
Dyspnoea	4	2	2
Chest tightness	5	8	7
Chest pain	2	6	4
Fever	2	1	2
Lose of weight	5	3	3
Malaise	9	7	9
Muscular pain	6	7	3
Headache	4	7	6

- Notes: 1. The number in parenthesis is specimen number.  
 2. The age of all the persons ranges from 25 to 40.  
 3. The gender of all the persons is male.  
 4. No smoking habit.

## REFERENCES

- [1] WANG, A., Chemical characterization of airborne particles in Beijing area, *Acta Science Circumstantiae* (in Chinese) 4 (1981) 220–223.
- [2] WORLD HEALTH ORGANIZATION, Biological monitoring of chemical exposure in the workplace, WHO/HPR/OCH, Geneva (1996).
- [3] INTERNATIONAL ATOMIC ENERGY AGENCY, Report on the First Research Coordination Meeting, NAHRES-7, Vienna (1991).
- [4] CHAI, Z.F., et al., A Study on Environmental Pollution Monitoring and Occupational Health in the Capital Iron and Steel Company, Beijing, China, Using Nuclear and Related Analytical Techniques, IAEA, Belo Horizonte, Brazil (1999).
- [5] CHAI, Z.F., et al., *ibid*, IAEA, Vienna (1997).
- [6] IYENGAR, G.V., *Elemental Analysis of Biological Systems*, CRC Press, Washington, D.C., (1989).





# ASSESSMENT OF OCCUPATIONAL EXPOSURE IN MANUFACTURING OF STAINLESS STEEL CONSTRUCTIONS USING DETERMINATION OF SELECTED METALS IN THE WORKPLACE AIR AND BODY TISSUES BY NEUTRON ACTIVATION ANALYSIS AND IMMUNOLOGICAL TESTS<sup>1</sup>

J. KUČERA<sup>1</sup>, L. BORSKÁ<sup>2</sup>, V. BENCKO<sup>3</sup>, J. TEJRAL<sup>4</sup>, Z. ŘANDA<sup>1</sup>, L. SOUKAL<sup>1</sup>, V. HNATOWICZ<sup>1</sup>

<sup>1</sup> Nuclear Physics Institute, Řež near Prague, Czech Republic

<sup>2</sup> Institute of Pathological Physiology, Faculty of Medicine, Charles University, Hradec Králové, Czech Republic

<sup>3</sup> Charles University of Prague, 1<sup>st</sup> Faculty of Medicine, Institute of Hygiene and Epidemiology, Czech Republic,

<sup>4</sup> Institute of Hygiene and Preventive Medicine, Faculty of Medicine, Charles University, Hradec Králové, Czech Republic

## Abstract

Exposure to workplace airborne pollutants was examined in a group of 20 workers dealing mainly with welding, polishing, and assembling of stainless steel constructions. Airborne particulate matter (APM) collected using both personal and stationary samplers was assayed for a number of elements by instrumental neutron activation analysis (INAA). Biological monitoring involved the determination of Cr, Mn, Mo, Ni and V in hair and nails by INAA, urinary Cr and Mn, and blood Mn by neutron activation analysis with radiochemical separation (RNAA). Hematological, genotoxicity and immunological assays were also performed to be able to evaluate the health status of the exposed workers. Quality assurance procedures of both sampling and analytical stages are described. The maximum admissible limit for workplace pollutants was exceeded only for the median concentration of chromium in workplace APM, while for nickel the limit was exceeded in several individual cases. Significantly elevated levels were found for Cr in hair, nails and urine, Mo in hair, and Mn in blood in the exposed subjects compared to controls. A number of immunological parameters was altered in the exposed group as well.

## 1. INTRODUCTION

The substances with the known and/or possible adverse health effects in occupational settings are numerous. Workers in mining, metal refining and metal working industries are exposed to airborne particulate matter containing various levels of metals with known neurotoxicity, genotoxicity, carcinogenic, allergenic and immunological effects [1]. In manufacturing of stainless steel constructions, the main health risk is associated with inhalation of welding fumes and APM originating from manufacturing of the constructions, which contain elevated levels of steel-alloying elements, such as Cr, Ni, Mo, Mn, V, etc.

---

<sup>1</sup> Work performed within the framework of the IAEA CRP on Assessment of Levels and Health-Effects of Airborne Particulate Matter in Mining, Metal Refining and Metal Working Industries Using Nuclear and Related Analytical Techniques (Research contract No. 302-E4-CZR-9475) and grant No. 202/K0038 provided by the Grant Agency of the Czech Republic.

In connection with the prevention of the adverse health effects of harmful substances in occupational and environmental settings, there is a growing need to harmonize activities in the field of toxicological methodology and approaches to risk assessment [2]. The results of direct monitoring, i.e. the assessment of exposure from concentrations of toxic substances in air, water, food, workplace, etc., may be misleading, if various mechanisms of intake and/or absorption lead to a different burden of the organism, if multiple mechanisms of intake are to be considered, and especially if short- and long-term effects are to be distinguished [3]. Therefore, in the assessment of health risk arising from environmental, occupational and accidental exposure to toxic metals and other substances, the use of biological monitoring is steadily increasing [4–6]. This approach is facilitated if reliable biological indicators of exposure, such as changes of a concentration of the substance of interest, its metabolites, and other specific species in indicator or target tissues, are well established.

Both approaches were used in the present work in which occupational exposure was examined in a group of 20 workers of a plant manufacturing storage and production vessels for the pharmaceutical, food and chemical industries made of austenitic stainless steel containing on average 18% of Cr, 9–10% of Ni, 2–2.5% of Mo, 1–2% of Mn and traces of V (~ 0.01%). The main sources of exposure to these metals are welding fumes and APM originating from polishing, shaving and drilling of the vessels and/or stainless steel sheets from which the vessels are made. Exposure to workplace airborne pollutants was examined using both personal and stationary samplers. Multielemental analysis of airborne particles was carried out by INAA. For biological monitoring, samples of hair, nails, blood, urine and saliva were collected. In these tissues, Cr and Mn were determined by INAA in hair and nails, whereas RNAA was employed for determination of Cr in urine and serum by RNAA, and for determination of Mn in urine and whole blood. To be able to evaluate the health status of the exposed workers, a number of hematological, genotoxicity, and immunological parameters were examined.

The same exposure and health status indicators were examined in a group of controls which consisted of 21 workers in an agricultural enterprise located in the vicinity of the above given manufacturing plant (for the determination of metals, hematological and genotoxicity test). A more numerous group of laboratory employees (30 to 100 subjects) was used for studying immunological parameters. The results achieved are discussed in the present paper.

## 2. METHODS

### 2.1. Subjects and their exposure

The group of exposed workers consisted of 18 men and 2 women of the average age of 33.1 years. The subjects have been working in the plant for 15.9 years on average and 52% of them were smokers. They were occupationally exposed to welding fumes and/or APM originating from various activities in the production of stainless steel vessels, mainly polishing and shaving. Only women of this group were involved in one type of activities (polishing), men were changing their activities during a week (or even during a shift). Workers involved in polishing were equipped with respirators, while welders did not use them. Most of the working activities took place in the main assembling hall (50 x 40 x 5 m) equipped with a ventilation system. Moreover, most workplaces where welding and polishing was carried out were equipped with local exhausts.

The first control group was formed by 20 men (average age of 45.5 years, 47% smokers) employed in an agricultural enterprise located about 5 km from the plant producing stainless steel vessels.

## **2.2. Sampling of airborne particulate matter**

For the personal full-shift monitoring an SKC 224 PCRX-4 (USA) constant flow pump was used equipped with a sampling head with mixed cellulose ester (MCE) matched-weight filters having a 32 mm diameter and a 0.8  $\mu\text{m}$  pore size (SKC Cat. No. 225–502). The constant flow rate was set to 2 L  $\text{min}^{-1}$ , and was checked with the aid of a flowmeter three times during sampling. Each worker was sampled twice during a week for the whole 8-hour shift (working activities took place usually in the range of 6 to 7 hours).

Stationary sampling was carried out in the centre of the assembling hall. The “Gent” stacked filter unit (SFU) was employed with the PM10 inlet and stacked cassette with two sequential polycarbonate (Nuclepore) filters of a diameter of 47 mm with a pore size of 8  $\mu\text{m}$  and 0.4  $\mu\text{m}$ , operating at a flow rate of 16 L  $\text{min}^{-1}$  [7]. Under these conditions, size fractionating of APM occurs so that the former filter collects APM having equivalent aerodynamic diameter (EAD) in the range of 2–10  $\mu\text{m}$  EAD (so-called “coarse” fraction), while the latter filter collects APM with EAD < 2  $\mu\text{m}$  (so-called “fine” fraction).

## **2.3. Sampling of biological material**

Blood and urine for elemental analysis were sampled in conditions preventing external contamination. Both exposed workers and controls took shower and were given a clean laboratory coat prior to sampling. Approximately 5 mL of blood were obtained from cubital vein using a Teflon canula which was first flushed with 15 mL of blood collected for immunological tests. For these tests, saliva was also collected. Approximately 5 mL of blood were collected in polyethylene (PE) cryogenic vials (Nalgene) which were pre-cleaned as given below. Aliquots of 1 to 2 mL of blood were immediately transferred to other Nalgene vials for determination of manganese, while the remaining blood was centrifuged to obtain serum for chromium determination. Serum aliquots of 1 mL to 1.5 mL were placed into pre-cleaned vials made of synthetic quartz (Suprasil AN, Heraeus). The quartz vials were closed with an acid leached Teflon stopper. All manipulations on blood sampling and handling were performed in the stream of air obtained from a mobile filtration unit with ULPA filters (Holten) providing Class 10 environment. Spot samples of urine of a volume 50 mL to 100 mL were collected in acid leached polystyrene vials. The blood and urine samples were deep-frozen prior to analysis. Hair and nail samples were obtained by clipping with stainless steel scissors. While the IAEA recommended procedure was employed for hair washing (acetone-water-water-water-acetone) [8], the adapted procedure described elsewhere [4] was used for nail cleaning. The collection of biological materials was carried out on the second and fourth day of a week for controls and exposed workers, respectively, at the beginning of a shift.

All collection vials used for sampling and sample handling were pre-cleaned by leaching in dilute sub-boiled nitric acid for 24 hours and washing with deionized water in a clean laboratory providing Class 100 environment.

## 2.4. Instrumental neutron activation analysis (INAA)

The samples of APM on filters of both types, hair samples weighing 75 to 150 mg, and nail samples weighing 10 to 75 mg were packed for irradiation in acid leached disk shaped PE capsules of a diameter 15–25 mm made by heat-sealing of PE foils 0.15 mm thick. Synthetic multielement standards were prepared by weighing out 20–50  $\mu\text{L}$  aliquots containing known amounts of elements onto disks of chromatographic paper Whatman 2, air drying and heat-sealing into PE capsules. Their geometrical parameters (shape and thickness) matched that of the samples.

The samples and standards were irradiated in a nuclear reactor VVR-15 of the Nuclear Research Institute Řež, plc. at a thermal neutron fluence rate of  $1.10^{14} \text{ cm}^{-2} \text{ s}^{-1}$ . Short-time irradiation (1 min.) was carried out with the aid of a pneumatic facility with the transport time of 4 s. The samples and standards were irradiated in PE rabbits individually, together with neutron flux monitors (5  $\mu\text{g}$  of gold prepared as the standards) to check the neutron flux gradient, and were rigidly held in place with polystyrene blocks to ensure the reproducible irradiation geometry. For long-time irradiation (2 hours) in aluminum cans, about 30 samples and standards were placed together in one can to form a column and the neutron flux monitors were inserted between each set of 5 samples and/or standards to check the axial neutron flux gradient.

After irradiation, the PE capsules with the samples and standards were cleaned on their surface with water and ethylalcohol. Short lived radionuclides were counted using a coaxial HPGe detector (Ortec, rel. efficiency 11%, FWHM 1.75 keV for the 1332.5 keV photons of  $^{60}\text{Co}$ ) and associated linear electronics capable of maintaining high count rates. Both decay and counting times were 5 min., the counting geometry was 7 cm. Intermediate and long lived radionuclides were counted with another coaxial HPGe detector (PGT, rel. efficiency 21%, FWHM 1.85 keV for the 1332.5 keV photons of  $^{60}\text{Co}$ ). A Nuclear Data 699 Loss Free counting module was employed in the electronic chain of both detectors to perform the necessary corrections for the variable count rate and dead time. Two counts were performed after long-time irradiation, the first after the decay time of 4 days for 30 min. (counting geometry 1 cm), the second after one month of decay for 2–3 hours in the same counting geometry as in the first count. The Nuclear Data software for NAA was employed for data reduction. Other details on counting equipment and parameters of radionuclides employed have already been given earlier [9].

## 2.5. Radiochemical neutron activation analysis

### 2.5.1. Determination of chromium in urine and serum

Freeze dried serum (originally 1 to 1.5 mL) or 1 mL liquid urine samples were irradiated in vials made of synthetic quartz (Suprasil AN, Heraeus, Germany) pre-cleaned as described above for 20 hours at a thermal neutron fluence rate of  $1.10^{14} \text{ cm}^{-2} \text{ s}^{-1}$  in the VVR-15 nuclear reactor. After 1 to 2 weeks of decay, the quartz vials were cleaned on their surface by leaching in hot aqua regia and cooled in liquid nitrogen. After opening the vials, urine was washed out with 5 to 10 mL of distilled water, while serum was solubilized in 5 mL of fuming nitric acid in a beaker. Radiochemical separation of  $^{51}\text{Cr}$  was carried out using a procedure similar to that described by Greenberg and Zeisler [10]. To both sample types, 4 mg of chromium inactive carrier (1 mL of a  $\text{K}_2\text{CrO}_4$  solution containing 4 mg of Cr per mL), 3 mL of concentrated  $\text{H}_2\text{SO}_4$  (and 1 mL of concentrated  $\text{HNO}_3$  in the case of urine) were added.

Then, the samples were transferred to a Kjehldal decomposition flask made of natural quartz and mineralized by repeated additions of 1 mL aliquots of concentrated HNO<sub>3</sub> during heating the flask over a gas burner until a clear solution was obtained and white fumes of H<sub>2</sub>SO<sub>4</sub> appeared. Then, Cr (III) was oxidized to Cr (VI) by addition of 1 mL of concentrated HClO<sub>4</sub> and heating till white fumes of HClO<sub>4</sub>, and colour of the solution changed from green to orange. After cooling down to laboratory temperature, 1 mL of a 0.05 mol L<sup>-1</sup> KMnO<sub>4</sub> solution and 25 mL of a 2.5 mol L<sup>-1</sup> HCl were added and Cr(VI) was extracted for 1 min. by two 10 mL-portions of a 5% (w/v) solution of tribenzylamine (TBA) in chloroform. Combined chloroform fractions were scrubbed with 5 mL of water for 30 s (to separate part of Zn co-extracted) and Cr was stripped into water phase with 5 ml of 3 mol L<sup>-1</sup> NH<sub>4</sub>OH for 90 s. After washing the separatory funnel with 1 mL of water, the 6-mL fractions with separated <sup>51</sup>Cr were counted using a 150 cm<sup>3</sup> well type HPGe detector for 4 to 10 hours. The chemical yield of separation that varied in the range of 90–95% was determined by reactivation of 25-μL aliquots of the water phase containing theoretically 16.66 μg of chromium inactive carrier.

### 2.5.2. Determination of manganese in urine and blood

Frozen blood samples in their collection Nalgene vials and 1 mL of frozen urine samples in acid-leached PE vials were irradiated for 1 min. at a thermal neutron fluence rate of 8.10<sup>13</sup> cm<sup>-2</sup> s<sup>-1</sup> and a fast neutron fluence rate of 2. 10<sup>13</sup> cm<sup>-2</sup> s<sup>-1</sup> using a pneumatic transfer system of the VVR-15 nuclear reactor. Radiochemical separation of <sup>56</sup>Mn was performed using a slightly adapted procedure described earlier [11], which is briefly described as follows. The irradiated samples were transferred to a Kjehldal decomposition vial made of natural quartz to which 200 mL of a MnSO<sub>4</sub> solution containing 5 mg of Mn per mL (1 mg of Mn inactive carrier), 25 mL of a radioactive <sup>54</sup>Mn tracer solution (approximately 500 Bq) and 3 mL of concentrated H<sub>2</sub>SO<sub>4</sub> were added. Sample decomposition was carried out by repeated addition of 1 mL aliquots of concentrated HNO<sub>3</sub> (in total 5 to 6 mL and 1 to 2 mL for blood and urine, respectively) and heating the flask over a gas burner until a clear solution was obtained. The solution was then cooled down, transferred to a beaker, diluted with 35 mL of water, 13 mL of concentrated NH<sub>4</sub>OH were added to reach pH ~ 8, then 5 mL of a 5% (NH<sub>4</sub>)<sub>2</sub>S<sub>2</sub>O<sub>8</sub> solution were added and hydrated MnO<sub>2</sub> and Fe(OH)<sub>3</sub> were precipitated by a short boiling on a hot plate. The resulting precipitate was filtered off after cooling using a membrane filter Synpor (Pragochem, Czech Republic) with a pore diameter of 0.4 mm. The separation procedure took approximately 20 min. The chemical yield of Mn separation as determined by measuring the <sup>54</sup>Mn tracer was in the range of 95–99%.

The activity of <sup>56</sup>Mn (the 846.x keV and 1810.9 keV γ rays) and <sup>54</sup>Mn (the 834 x keV γ rays) was counted using a coaxial HPGe detector (rel. efficiency 53%, FWHM resolution of 1.8 keV, both for the 1332.5 keV photons of <sup>60</sup>Co) for 20 min. After counting, the filters were irradiated for 2 hours to determine the content of Fe to be able to correct for the interfering reaction <sup>56</sup>Fe(n,p)<sup>56</sup>Mn with fast neutrons. The interference contribution yielded 16.4 ng of “apparent” Mn per μg of Fe as determined by NAA of certified reference material (CRM) JSS 003–4 High Grade Pure Iron 3 with a certified content of Mn (32.2 ± 1.65 mg kg<sup>-1</sup> [12]) was negligible for analysis of urine, but in the case of blood about a half of <sup>56</sup>Mn measured originated from the above interfering reaction. Another interfering reaction <sup>59</sup>Co(n,α)<sup>56</sup>Mn with fast neutrons was negligible for both matrices due to a very low Co content.

## 2.6. Haematological, genotoxicity and immunological assays

Haematological tests and the cytogenetical examination of chromosomal aberrations of peripheral lymphocytes were carried out using the standard procedures.

The phagocytosis activity was tested using yeast ingestion. The ELISA method was employed for determination of levels of serum neopterin (IBL, Germany) and  $\beta$ -2-microglobulin (RDS, USA). To monitor the mucous membrane response, saliva was assayed for lysozyme and secretory immunoglobulin A (IgA) levels by turbidimetry after a correction for albumin (The Binding Site, UK). The ELISA method was also employed for determining concentrations of serum interleukin IL-1- $\beta$  (Quantikin RDS, USA) and total IgE (Immunotech, France). Levels of IgA, IgG, IgM, C3 and C4 constituents of complement, and CRP in serum were determined by turbidimetry using Beckman (USA) immunological kits. Details of these and other assays have already been reported [13].

## 2.7. Statistical evaluation

Differences between parameters of the exposed and control groups were tested using the Student's t-test and Mann-Whitney U-test for normally and non-normally distributed data sets, respectively. The normality of distribution was examined using Kolmogorov-Smirnoff-Liliefors and Shapiro-Wilk tests. For testing, the software STATISTICA (Statsoft, USA) was employed.

## 3. RESULTS AND DISCUSSION

### 3.1. Quality assurance

#### 3.1.1. *Quality control of personal sampling of APM*

The mass difference of matched-weight SKC filters for personal samplers within 50  $\mu$ g is guaranteed by the producer. Seven cassettes were dismounted and both filters, later on used for determination of element blank values, were weighed using a microbalance MT 5 (Mettler-Toledo) with readability of 1  $\mu$ g. The mass differences in the range of 8  $\mu$ g to 50  $\mu$ g (mean 18  $\mu$ g) were found in agreement with the producer specification. The mass of APM collected in the described conditions ranged from 0.240 mg to 6.950 mg (mean 1.291 mg). Thus, the uncertainty due to the mean mass difference of the filters is only 1.4% for the mean mass of APM (when elemental concentration is given as a mass fraction), while for the lowest mass of APM collected this uncertainty amounts to 7.6%. Therefore, it seems that element concentrations expressed in mass per volume provides data with a lower uncertainty, because the flow rate through the sampler can be checked several times during the sampling period, and the possible deviations from the pre-set flow rate can be accounted for.

It has been noticed that some amount of APM is passing through the upper filter of the pair of the matched-weight SKC filters. Therefore, the elemental composition of APM deposited on the backing filter was also measured in 8 randomly selected pairs of filters. Amounts of the elements studied in the backing filters were in the range of 0.5% to 2.0% relative to the upper filter and thus can be considered negligible.

### 3.1.2. Quality control of elemental analysis of APM, hair and nails by INAA

A few mg aliquots of NIST SRM-1648 Urban Particulate Matter were regularly co-analysed with samples of loaded filters, hair and nails. Although about 40 elements were determined using INAA in the above sample types, only the results for Cr, Mn, Mo, Ni and V are reported due to their relevance for this study. Table I shows that the results obtained compare well with the NIST certified values [14] within the uncertainty margins. The matrix independence of INAA guarantees that accuracy of our results was proved not only for analysis of APM on filters, but also for hair and nail analysis.

TABLE I: RESULTS FOR NIST SRM-1648 URBAN PARTICULATE MATTER

Element, mg kg <sup>-1</sup>	Cr	Mn	Mo	Ni	V
This work <sup>a</sup>	395 ± 20	782 ± 15	19.8±1.8	80 ± 5	126 ± 4
NIST certified value [14]	403 ± 12	786 ± 17	18.2±1.9 <sup>b</sup>	82 ± 3	127 ± 7

<sup>a</sup> –  $\bar{x} \pm s$ ; N=8–10

<sup>b</sup> – literature value [15]

### 3.1.3. Quality control of Cr and Mn determination in urine, serum or blood

Two 0.5 mL aliquots of a control sample Seronorm<sup>TM</sup> Trace Elements Urine [16] with a declared value of Cr of 20 µg L<sup>-1</sup> and two aliquots of intercomparison testing samples AMIQAS with managed, but unknown levels of Cr (low, medium and high) were analysed for quality control of the Cr determination by RNAA. Our mean of 19.45 µg L<sup>-1</sup> for the Seronorm<sup>TM</sup> control sample is in agreement with the above declared value. The mean values for low-, medium- and high-Cr-level AMIQAS intercomparison samples of 1.36, 6.10 and 20.2 µg L<sup>-1</sup> compare well with the respective target values and their standard deviation of 1.47 ± 0.23, 6.4 ± 0.41 and 20.95 ± 0.84 µg L<sup>-1</sup> [17].

In the case of Mn, IAEA RM A-13 Freeze Dried Animal Blood, and H-4 Animal Muscle were analysed for quality control purposes. The Mn value ( $\bar{x} \pm s$ , n=3) of 30.8 ± 3.9 µg kg<sup>-1</sup> (dry mass) determined in IAEA RM-13 agrees with a literature value of 31 ± 2.6 [11] within uncertainty margins. Similarly, the Mn value of 465 ± 13 µg kg<sup>-1</sup> (dry mass) obtained for IAEA RM H-4 is in agreement with the IAEA upgraded value of 466 ± 42 µg kg<sup>-1</sup> [18].

## 3.2. INAA results of APM collected using personal and stationary samplers

The workers of the plant are involved in two or three types of working activities within a week or even within a shift. This also occurred during the sampling campaign, which lasted one week. Therefore, each worker was sampled twice during this week, to be able to correlate the “average” exposure measured by direct monitoring with results of biomonitoring.

For the first part of evaluation, exposure of the individual workers (as measured using the personal samplers) was not considered. The workers were grouped according to the prevailing working activity during the sampling campaign into 3 categories: welding (W), polishing (P) and other activities, such as cutting stainless steel sheets, drilling, and assembling of the



vessels (O). Exposure to the selected elements within these groups as evaluated from INAA results of the personal samplers is given in Table II.

TABLE II: CONTENTS OF SELECTED METALS IN WORKPLACE APM COLLECTED USING PERSONAL SAMPLERS ( $\mu\text{g m}^{-3}$ )

Element	Cr	Mn	Mo	Ni	V
MAL <sup>a</sup> [1]	50	2000	5000	50	1000
Working category W (N=15)					
Range	19.5–169	4.5–109	0.27–9.7	5.0–39.9	0.10–0.68
Median	56.4	18.1	1.45	17.7	0.23
MAL exceeded, % <sup>b</sup>	69	0	0	0	0
Working category P (N=9)					
Range	2.6–260	1.6–81.3	0.03–4.2	1.1–118	0.021–0.79
Median	54.5	8.1	0.82	24.0	0.24
MAL exceeded, % <sup>b</sup>	44b	0	0	33	0
Working category O (N=15)					
Range	7.6–35.8	3.2–10.5	0.14–0.60	2.7–14.5	0.041–0.17
Median	14.4	4.3	0.32	4.9	0.069
MAL exceeded, % <sup>b</sup>	0	0	0	0	0

<sup>a</sup> – maximum admissible limit [1]

<sup>b</sup> – percentage of values exceeding maximum admissible limit

<sup>c</sup> – for details see text

Since most of the results were not normally distributed [19], the median value of element contents appeared to be the most appropriate for comparing exposure amongst the groups. Table II shows that the highest concentrations were found in the breathing zone of welders for Cr, Mo and Mn, while the highest Ni concentrations were found in the group of workers dealing mostly with polishing (part of their activities was also welding). About the same values for V vanadium were found in all three groups. Since this element is contained in the type of steel manufactured in a low concentration, the workers are probably exposed only to a “background” concentration of vanadium in the assembling hall. The lowest values for all elements studied were found in the group of workers denoted “O” dealing with drilling and assembling of the stainless steel vessels as was expected.

Most important, however, is a comparison of the values found with the maximum admissible limits (MAL) for pollutants in the workplace air that are also shown in Table II. It can be seen that only the median values of chromium in the groups with prevailing welding and polishing activities (groups “W” and “P”) exceeded the maximum admissible limits. Higher values than the limits were found for 69% and 44% of the workers involved in the respective working activities. For other elements and groups, significantly lower values were found compared to the MAL, except for Ni in the group of workers “P” predominantly dealing with polishing where the limit was exceeded in 33% of the subjects studied.

Using the personal samplers employed in this work, the total suspended particulate (TSP) matter without any particle size fractionation was obtained. In this case, the assessment of the health risk associated with elevated levels of pollutants in the workplace air is rather difficult, because a portion of particles that can be inhaled is not known. To obtain more relevant information about levels of the inhalable fraction of the workplace air pollutants, the particles

with EAD 2–10  $\mu\text{m}$  (so-called coarse fraction) and  $< 2 \mu\text{m}$  (so-called fine fraction) were also analysed. The results obtained in four whole-shift sampling campaigns are shown in Table III.

TABLE III: ELEMENTAL COMPOSITION OF SIZE FRACTIONATED APM IN THE WORKPLACE AIR,  $\mu\text{g m}^{-3}$

Element	Cr	Mn	Mo	Ni	V
“Coarse” fraction (EAD 2–10 $\mu\text{m}$ )					
Range	5.49–15.2	2.60–5.86	0.015–0.087	1.81–4.81	0.029–0.072
Median	9.23	3.16	0.034	3.57	0.042
“Fine” fraction (EAD $< 2 \mu\text{m}$ )					
Range	1.32–2.48	0.73–1.51	0.093–0.54	0.35–0.53	0.005–0.007
Median	1.36	1.16	0.15	0.39	0.0069

Obviously, much lower values were found for all elements studied in the “coarse” and “fine” fractions compared to TSP, especially for the latter, respirable fraction. The values determined using both types of samplers are difficult to compare, because the location of sampling devices was different (the breathing zone of workers versus the common workplace air in the assembling hall). Nevertheless, the results for the size fractionated APM suggest that workers of the plant examined are subjected to a lower occupational exposure than it could be concluded from the results of TSP measurement, because the respirable fraction contains only a small fraction of the element contents determined in TSP.

### 3.3. INAA and RNAA results of element determination in body tissues and/or fluids

Hair is frequently employed as a suitable bioindicator of environmental and occupational exposure [6, 20, 21]. Nails, as another ectoderm derivative, can serve for monitoring of exposure to chemicals as well [3, 21]. Table IV shows the results obtained for Cr, Mn, Mo, Ni and V in hair and nails of the exposed and control groups.

TABLE IV: RESULTS OF ELEMENTAL ANALYSIS OF BODY TISSUES AND/OR FLUIDS OF EXPOSED AND CONTROL PERSONS BY NAA

Tissue/Fluid	Unit	Exposed		Controls		Significance of differences			
		$\bar{x} \pm s^a$	$\tilde{x}$ (LQ, UQ) <sup>b</sup>	N	$\bar{x} \pm s^a$	$\tilde{x}$ (LQ, UQ) <sup>b</sup>	N	p-value	Significance <sup>c</sup>
Hair Cr	mg kg <sup>-1</sup>		2.84 (1.58, 5.84)	22	0.227 (0.207, 0.263)	21	<0.001	***	Mann-Whitney
Nail Cr	mg kg <sup>-1</sup>		12.8 (8.15, 43.6)	20	2.93 (1.42, 5.80)	20	<0.001	***	Mann-Whitney
Hair Mn	mg kg <sup>-1</sup>		1.05 (0.73, 1.50)	22	0.652 (0.293, 1.715)	21	0.224	NS	Mann-Whitney
Nail Mn	mg kg <sup>-1</sup>		0.973 (0.729, 1.757)	22	1.08 ± 0.52	19	0.656	NS	Mann-Whitney
Hair Mo	mg kg <sup>-1</sup>		0.351 (0.265, 0.435)	22	0.258 ± 0.070	21	0.0015	**	Mann-Whitney
Nail Mo	mg kg <sup>-1</sup>		3.25 (1.63, 3.78)	20	3.48 (2.29, 4.47)	20	0.126	NS	Mann-Whitney
Hair Ni	mg kg <sup>-1</sup>	< 2		22	< 2	21		-	-
Nail Ni	mg kg <sup>-1</sup>	< 4		20	< 4	19		-	-
Hair V	mg kg <sup>-1</sup>	0.242±0.182	0.049 (0.040, 0.060)	22	0.029 (0.019, 0.062)	21	0.078	NS	Mann-Whitney
Nail V	mg kg <sup>-1</sup>		4.41 (2.74, 6.52)	20	0.103 (0.084, 0.153)	19	0.158	NS	Mann-Whitney
Urinary Cr	µg L <sup>-1</sup>			17	0.49 (0.34, 1.31)	19	<0.001	***	Mann-Whitney
Blood Mn	µg L <sup>-1</sup>	9.14±1.84		18	7.16 ± 2.86	19	0.014	*	t-test
Urinary Mn	µg L <sup>-1</sup>		1.11 (0.67, 1.71)	20	0.92 ± 0.049	21	0.126	NS	Mann-Whitney

<sup>a</sup> – arithmetic mean ± standard deviation for normally distributed data sets

<sup>b</sup> – median (lower quartile, upper quartile) for non-normally distributed data sets

<sup>c</sup> – \*\*\*: highly significant (p<0.001); \*\*: significant (0.01<p >0.001); \*: marginally significant (0.05<p >0.01); NS: non-significant (p >0.05)

TABLE V: COMPARISON OF ELEMENT LEVELS IN BODY TISSUES AND/OR FLUIDS OF CONTROLS WITH REFERENCE VALUES

Body fluid/element	This work	Reference value <sup>a</sup> [22]	Exp. concentration [23]	IFCC Ref. interval	IUPAC coverage interval
Hair Cr, $\mu\text{g kg}^{-1}$	227 (207, 263) <sup>b</sup>	460 (60–1400)			
Hair Mn, $\mu\text{g kg}^{-1}$	652 (293, 1715) <sup>b</sup>	1200 (200–4000)			
Hair Mo, $\mu\text{g kg}^{-1}$	258 $\pm$ 70 <sup>c</sup>	380 (100–490)			
Urinary Cr, $\mu\text{g L}^{-1}$	0.49 (0.34, 1.31) <sup>b</sup>	0.4 (0.24–1.8)	< 1	< 0.052–0.57	< 0.052–0.57
Blood Mn, $\mu\text{g L}^{-1}$	7.16 $\pm$ 2.86 <sup>c</sup>	13.6 (8.0–18.7)	8	4.7–16.3	4.7–16.3
Urinary Mn, $\mu\text{g L}^{-1}$	0.92 $\pm$ 0.049 <sup>c</sup>	0.6 (0.5–9.8)	1	< 0.088–3.43	< 0.088–3.19

<sup>a</sup> – median (range); <sup>b</sup> – median (lower quartile, upper quartile); <sup>c</sup> – mean  $\pm$  standard deviation

Compared to the controls, highly significant ( $p < 0.001$ ) elevated levels of Cr in hair and nails, and significantly increased ( $0.01 < p < 0.001$ ) hair Mo were found in the exposed workers. No significant differences were found between both groups for Mn in hair and nails, Mo in nails, Ni in hair and nails (Ni values in both tissues were below a detection limit for both groups), and V in hair and nails.

It should be realized, however, that the significantly elevated levels of Cr in hair and nails and those of Mo in hair should be interpreted with caution as a proof of occupational exposure. The reason is that there is no hair cleaning procedure which would completely remove the exogenous contamination (caused by e.g. elevated element levels in the workplace air) without influencing the endogenous element content in hair [20]. The above statement is even much more severe for nail analysis, because removing of the exogenous contamination from this tissue is much more difficult compared to hair. Moreover, unlike the IAEA hair washing procedure [8], no generally accepted procedure for nail cleaning has been recognized until now.

Urinary and blood element levels are regarded much more straightforward biological indicators of occupational exposure [21]. Depending on the element and its association with blood components, whole blood, serum and/or plasma should appropriately be chosen for analysis to obtain relevant information about recent and/or long-term exposure, or even about element speciation. Highly sensitive analytical techniques must be employed for the determination of elements of interest due to their very low concentrations in these body fluids, namely in control groups. RNAA is one of the techniques of choice. In our study, urinary Cr and Mn, and blood Mn were determined by RNAA until now, the determination of serum Cr and urinary Ni is still in progress. Table IV shows a highly significant increase ( $p < 0.001$ ) of urinary Cr and a marginally significant increase ( $0.05 < p < 0.01$ ) of blood Mn in exposed subjects compared to controls, whereas no significant differences in urinary Mn between both groups were found. Since urinary Cr appears the most suitable indicator for monitoring of occupational exposure to Cr [21, 23], the results obtained demonstrate a significant exposure of the workers to this element. Exposure to Mn can also be considered proven from elevated levels of blood Mn. This finding is not in contrast with non-increased levels of urinary Mn, because the Mn excretion in urine is low, although this biological indicator is used to estimate recent Mn exposure [21].

It should be emphasized that the accurate determination of normal Mn levels in blood urine and normal Cr levels in urine is a demanding analytical task, because of a high risk of contamination. Table V shows that our values for blood Mn and urinary Cr and Mn in controls compare well with literature reference values for healthy individuals. This agreement proves the accuracy of our results, namely the absence of contamination on sampling and sample handling, because the absence of analytical bias was shown by analysis of reference materials. It should also be pointed out that the concentrations of blood Mn and urinary Cr and Mn determined in this work are significantly lower than most of the recently reviewed values in the Czech and Slovak populations [24, 25]. However, the latter sets of data were obtained in conditions in which contamination on sampling and sample handling could not be excluded and accuracy of the results was not demonstrated.

### 3.4. Results of haematological and genotoxicity tests

Of the haematological parameters examined, such as leucocytes, erythrocytes, haemoglobin, haematocrit, neutrophils, eosinophils, basophils, lymphocytes, monocytes, thrombocytes, and rods only the number of rods was marginally significantly increased ( $0.05 < p < 0.01$ ) in the exposed workers compared to controls [26].

No significant differences were found between the number of all types of aberrated cells in the exposed subjects and controls in the present study [26]. However, it may be pointed out that in another study recently conducted in the Czech Republic [27], steel welders and polishers exposed to higher levels of Cr and Ni in the workplace air than in the present study, exhibited a highly significant number ( $p < 0.001$ ) of aberrated cells, namely numerically aberrated cells compared to unexposed subjects.

### 3.5. Immunological profile

The first barrier against entering xenobiotic substances into organism is the body surface. If this is penetrated, then the agents come into contact with other components of the immunity system. Therefore, two indicators of the mucous membrane response — levels of lysozyme and secretory IgA in saliva — were examined in the present study. Table VI shows that no significant increase of both parameters was found in the exposed workers compared to controls.

Fagocytosis represents an important mechanism of elimination of xenobiotics from organism. A number and activity of fagocytizing cells indicates a burden of the cellular immunity system. A marginally significant decrease of the fagocytizing cells was found (Cf. Table IV) in the exposed group compared to controls, in agreement with other reports [26]. Levels of neopterin, interleukin-1- $\beta$ , and  $\beta$ -2-microglobulin can be considered other possible markers for cellular immune reactions. For these markers, a highly significantly, significant, and marginally significant increase, respectively, was observed in the exposed group compared to controls.

Regarding humoral immunity parameters, complement belongs to the most important defensive mechanisms of organism. The determination of C3 and C4 constituents of complement revealed a highly significant increase in the exposed group only for the former constituent. In accordance with other reports [27, 28] the immune-suppressive effect of welding fumes on the level of immunoglobulin M (IgM), a highly significant decrease of this parameter in the exposed group was also found in the present study. For the IgG levels, a marginally significant decrease was observed in the exposed group compared to the controls, whereas there were no significant differences in the IgA levels in both groups.

The interaction of xenobiotics with organism also manifests by reactions of hypersensitivity. The simplest marker of hypersensitivity is an increased level of total IgE. Thus, a marginally significant increase of IgE in the exposed group may be a result of the sensitization by exposure.

A burden of organism on acute actions (e.g. surgery interventions, malignity, stress, infection, etc.) results in altered levels of some proteins, which are called proteins of the acute phase ( $\alpha$ -1-antitrypsin,  $\alpha$ -2-macroglobulin, transferrin, orosomucoid, ceruloplasmin, haptoglobin, prealbumin, and c-reactive protein-CRP). Of these, the most important is CRP, which was

also assayed in the present study. Table VI shows highly significant increase in the exposed group compared to the control subjects.

### **3.6. Association of exposure with the response of biological markers**

The relationship between the results of direct monitoring of exposure (as measured by personal samplers) and those of biological monitoring (element levels in body tissues and/or fluids, and immunological parameters) was examined in order to be able to assess the relevance of both types of monitoring for individual subjects. For this purpose, the exposure data for Cr, Mo, Mn and V for each worker measured using the personal samplers twice during the sampling campaign were pooled and correlations with the elemental contents in body tissues and/or fluids, and with immunological parameters were examined. Due to a non-normal distribution of most data sets, a distribution-free measure of association was employed — the Spearman rank correlation coefficient.

TABLE VI: RESULTS OF IMMUNOLOGICAL ASSAYS FOR THE EXPOSED AND CONTROL GROUPS

Tissue/Fluid	Unit	Exposed		Controls		Significance of differences		Test <sup>c</sup>		
		$\bar{x} \pm s^a$	$\tilde{x}$ (LQ, UQ) <sup>b</sup>	N	$\bar{x} \pm s^a$	$\tilde{x}$ (LQ, UQ) <sup>b</sup>	N		p-value	Significance <sup>c</sup>
Lyzozyme in saliva	mg L <sup>-1</sup>	8.5 ± 5.5		20	6.3 ± 3.7		30	0.151	NS	t-test
Secretory IgA/alb	index	9.7 ± 5.6		20	7.0 ± 3.7		30	0.120	NS	t-test
Fagocytizing cells	%	41.6 ± 11.3		19	47.5 ± 8.25		50	0.020	*	t-test
β-2-microglobulin	mg L <sup>-1</sup>		1.54 (0.66, 1.88)	18		0.83 (0.63, 1.08)	48	0.021	*	Mann-Whitney
Neopterin	nmol L <sup>-1</sup>	12.92 ± 3.46		18	8.36 ± 2.63		48	< 0.001	***	t-test
Interleukin 1-β	ng L <sup>-1</sup>		3.55 (2.60, 4.50)	18		2.50 (1.30, 3.60)	35	0.004	**	Mann-Whitney
IgA	g L <sup>-1</sup>		2.80 (2.51, 3.29)	18		2.80 (2.40, 3.00)	100	0.248	NS	Mann-Whitney
IgE	IU mL <sup>-1</sup>		161.5 (54.0, 257.0)	18		84.5 (50.0, 150.0)	100	0.046	*	Mann-Whitney
IgG	g L <sup>-1</sup>	11.6 ± 2.4		18	13.4 ± 3.1		100	0.021	*	t-test
IgM	g L <sup>-1</sup>	0.92 ± 0.31		18		1.80 (1.00, 2.20)	100	< 0.001	***	Mann-Whitney
C3 of complement	g L <sup>-1</sup>	1.32 ± 0.17		18		0.70 (0.60, 0.80)	100	< 0.001	***	Mann-Whitney
C4 of complement	g L <sup>-1</sup>	0.27 ± 0.05		18		0.30 (0.20, 0.40)	100	0.074	NS	Mann-Whitney
CRP	g L <sup>-1</sup>	9.1 ± 7.9		18	2.5 ± 1.25		50	< 0.001	***	t-test

<sup>a</sup> – \*\*\*: highly significant (p < 0.001); \*\*: significant (0.01 < p < 0.001); \*: marginally significant (0.05 < p < 0.01); NS: non-significant (p > 0.05)



No significant correlations ( $p > 0.05$ ) were found between the element contents in TSP collected in the workers' breathing zone and those found in their body tissues and/or fluids or the immunological parameters studied in the present work.

In contrast with the expected positive correlations of the exposure data and the element contents in the marker tissues, mostly negative trends were observed. Two possible explanations of this finding may be suggested:

- The sampling campaign performed for two days yielded data on acute exposure during these two particular days, which is not representative of long-term exposure, which mostly affects element contents in the marker tissues, especially in hair and nails
- The personal samplers employed collected the total suspended particulates (TSP) in the workplace air. This data is not representative of the element amounts that enter the respiratory tract, because a portion of particles that are inhaled is not known.

In view of markedly lower concentrations of elements in the inhalable, so-called "fine" fraction ( $EAD < 2 \mu\text{m}$ ), of APM as measured using the Gent SFU (Cf. ch. 2.2.) in the plant assembling hall compared to TSP in the breathing zone of workers, the latter explanation appears more likely.

Similarly to biological markers of exposure, most of the expected association and trends between exposure and the response of immunological parameters, as given in ch. 3.5., were not observed. In addition to the explanations suggested above, another parameter should be taken into account regarding the immunological response of the exposed workers. It is recognized that the response of immunological parameters to various xenobiotic substances is not specific. Thus, if there are multiple sources of exposure, it is impossible to distinguish, both in the qualitative and quantitative ways, which individual source contributes to the alteration of the immune parameters. Therefore, it is worth of mentioning that in addition to the elevated element levels also non-negligible levels of polycyclic aromatic hydrocarbons (PAH) were found in the work place air of the construction plant as shown in Table VII. Until now, there are no MAD established for PAHs in the workplace air in the Czech Republic and therefore no assessment can be made on their influence on the health status of the exposed workers. Under these circumstances it is even more difficult to estimate what is the reason for the unexpected absence of correlations of the exposure data and the immune parameters for the individual workers than in the case of missing correlations of exposure and element contents in the marker tissues.

TABLE VII: CONCENTRATIONS OF POLYAROMATIC HYDROCARBONS (PAH) IN THE WORKPLACE AIR

PAH	ng m <sup>-3</sup>
Naphtalene	209.5–491
Acenaphtene	63.3–77.9
Fluorene	49.3–82.3
Phenanthrene	96.9–155.5
Anthracene	4.0–5.2
Fluoranthene	22.9–56.5
Pyrene	5.6–12.9
Benzo(a)anthracene	< 1
Chrysene	< 1–6.9
Benzo(b)fluoranthene	< 1
Benzo(k)fluoranthene	< 1
Benzo(a)pyrene	< 1
Dibenzo(ah)anthracene	< 1
Benzo(g,h,l)perylene	< 1
Indenol(1,2,3-cd)pyrene	< 1
Sum of PAH	458.4–881.4

On the other hand, it should be emphasized that the absence of the expected correlations between the exposure data (direct monitoring) and the response of biological markers of exposure on the “individual case” basis does not invalidate the findings obtained at the “group” (epidemiological) basis. A comparison of these two approaches rather indicates the problems associated with the evaluation of exposure from direct monitoring of individual cases and the necessity of use of appropriate personal samplers (i.e. with particle size fractionation) for this purpose.

#### 4. CONCLUSIONS

It has been demonstrated that INAA is very well suited for direct monitoring of occupational exposure to various metals from the workplace air due to its multielemental capability, low detection limits for many elements and due to its high inherent potential for accuracy. On the other hand, the results of this study indicate that measurement of the elemental composition of TSP (which is still a rather common practice of the public and/or occupational health survey in the Czech Republic) is of a limited value. It may even be misleading for the assessment of health risks, especially if inhalation is the main route of the uptake of pollutants by organisms. The reason is that no information is obtained on the respirable element amounts. For this purpose, use of personal samplers equipped with a cyclone (or another separation device) which provides cut-off for particles greater than 2–4  $\mu\text{m}$  is advisable for future studies. INAA has also proved very useful for analysis of hair and nails as possible biological markers of occupational exposure, although the data on element contents in these tissues are mostly difficult to interpret.

For biological monitoring employing more straightforward and unequivocal markers of exposure, such as elemental composition of urine and blood or blood compartments, the use of RNAA is mandatory to be able to determine most of the required elements in these body

tissues at both elevated and especially normal levels. Only using the RNAA mode, the capabilities of the technique can fully be exploited for highly accurate determination of elements at the ultratrace level, provided that contamination-free sampling and sample handling is maintained.

It has also been shown that multiple exposure sources should be expected in occupational settings, such as the occurrence of PAH in addition to elevated levels of metals in the workplace air of stainless steel welders. In such cases, the association of the alterations observed in immunological profile of the exposed persons, as another important and very sensitive part of biological monitoring, to a specific exposure source is becoming difficult, because the response of the immune parameters is not specific. However, only such an approach allows for the integral assessment of the exposure risk, the evaluation of the health status of exposed subjects and for taking the appropriate measures to minimize the health risk originating from occupational exposure.

## REFERENCES

- [1] BENCKO, V., CIKRT, M., LENER, J., Toxic metals in the working and living environment of man (in Czech), Avicenum, Prague (1995).
- [2] BENCKO, V., UNGVÁRY, G., Risk assessment and environmental concerns of industrialization: A Central European experience, in JEYARATNAN, J., CHIA, K.S., (Eds.), Occupational Health in National Development, World Scientific, Singapore, New Jersey, London (1995).
- [3] KUČERA, J., LENER, J., MŇUKOÁ, J., BAYEROVÁ, E., Vanadium exposure tests in humans, in Vanadium in the Environment, Part 2: Health Effects, NRIAGU, J.O. (Ed.), John Wiley & Sons, New York, Chichester, Weinheim, Brisbane, Singapore, Toronto (1998) 55–73.
- [4] CLARKSON, T.W., FRIBERG, L., NORDBERG, G.F., SAGER, P.R., Biological Monitoring of Toxic Metals, Plenum, New York (1988).
- [5] DILLON, H.K., HO, M.H., (Eds.), Biological Monitoring of Exposure to Chemicals, Metals. Wiley, New York (1991).
- [6] BENCKO, V., Use of human hair as a biomarker in the assessment of exposure to pollutants in occupational and environmental settings, Toxicology **101** (1995) 29–39.
- [7] MAENHOUT, W., FRANÇOIS F., CAFMAYER J., The “Gent” stacked filter unit (SFU) sampler for the collection of atmospheric aerosols in two size fractions: Description and instructions for installation and use, Applied Research on Air Pollution Using Nuclear-Related Analytical Techniques, IAEA-NAHRES-19, Vienna (1994).
- [8] RJABUCHIN, J.S., Activation analysis of hair as an indicator of contamination of man by environmental trace element pollutants, Report IAEA/RL/50, IAEA, Vienna (1978).
- [9] KUČERA, J., SOUKAL, L., Homogeneity tests and certification analyses of coal fly ash reference materials by INAA, J. Radioanal. Nucl. Chem., Articles **121** (1988) 245–259.
- [10] GREENBERG, R.R., ZEISLER, R., A radiochemical procedure for ultratrace determination of chromium in biological materials, J. Radioanal. Nucl. Chem., Articles **124** (1988) 5–20.
- [11] KUČERA, J., SOUKAL, L., FALTEJSEK, J., Low level determination of manganese in biological reference materials by neutron activation analysis, J. Radioanal. Nucl. Chem., Letters **107** (1986) 361–369.

- [12] The Japan Iron and Steel Federation, Certificate of Analysis, JSS 003-4, High Grade Pure Iron 3, Otemachi, Chiyoda-ku, Tokyo, Japan, June (1966).
- [13] BORSKÁ, L., ANDRÝS, C., FIALA, Z., TEJRAL, J., BENCKO, V., KUČERA, J., ŠMEJKALOVÁ, J., Immunological profile of men with occupational exposure to emissions from welding of stainless steel, *Prac. Lék.* **52** (2000) 63–68 (in Czech).
- [14] (US) National Institute of Standards & Technology, Certificate of Analysis, Standard Reference Material 1648, Urban Particulate Matter, Gaithersburg, MD 20899, (1999) (additional certification update).
- [15] GLADNEY, E.S., O'MALLEY, B.T., ROELANDTS, I., GILLS, T.E., Standard Reference Materials: Compilation of Elemental Concentration Data for NBS Biological, Geological, and Environmental Standard Reference Materials, NBS Spec. Pub. 260-111, Gaithersburg, MD, USA (1987).
- [16] Data-key for Seronorm™ Trace Elements Urine, Batch No. 009024, Nycomed Pharma AS, Oslo, Norway.
- [17] CHRISTENSEN, J.M., AMIQAS Proficiency testing report: Interlaboratory comparison survey of the determination of chromium, manganese, iron, titanium in welding dust and arsenic, cadmium, cobalt and chromium in urine; National Environmental Research Institute, Roskilde, Denmark (see pages 79–90 in this report).
- [18] BYRNE, A.R., CAMARA-RICA, C., CORNELIS, R., DE GOEIJ, J.J.M., IYENGAR, G.V., KIRKBRIGHT, G., KNAPP, G., PARR, R.M., STOEPLER, M., Results of a coordinated research programme to improve the certification of IAEA milk powder A-11 and animal muscle H-4 for eleven “difficult” trace elements, *Fresenius Z. Anal. Chem.* **326** (1987) 723–729.
- [19] KUČERA, J., BENCKO, V., PÁPAYOVÁ, A., ŠALIGOVÁ, D., TEJRAL, J., BORSKÁ, L., Monitoring of occupational exposure in manufacturing of stainless steel constructions, Part I: Chromium, manganese, molybdenum, nickel and vanadium in the workplace air of stainless steel welders, *Central Eur. J. Public Health* (2001).
- [20] CHATT, A., KATZ, S.A., Hair Analysis, Application in the Biomedical and Environmental Sciences, VCH Publishers, New York, Weinheim (1988).
- [21] Biological Monitoring of Chemical Exposure in the Workplace, Guidelines, Vols.1, 2, WHO, Geneva (1996).
- [22] IYENGAR, G.V., WOITTIEZ, J., Trace element in human clinical specimens: Evaluation of literature data to identify reference values, *Clin. Chem.* **34** (1988) 474–481.
- [23] CORNELIS, R., et al., Sample collection guidelines for trace elements in blood and urine, *Pure & Appl. Chem.* **67** (1995) 1575–1608.
- [24] KUČERA, J., BENCKO, V., SABBIONI, E., VAN DER VENNE, M.T., Review of trace elements in blood, serum and urine for the Czech and Slovak populations and critical evaluation of their possible use as reference values, *Sci. Total. Environ.* **166** (1995) 211–234.
- [25] KUČERA, J., BENCKO, V., Normal concentrations of trace elements in the Czech and Slovak populations for biomonitoring purposes. Part I: Al, As, Cd, Co, Cr, Cs, Cu, F, Mn and Ni in blood, serum and urine (in Czech), *Pracov. Lék. (Prague)* **49** (1997) 68–78.
- [26] TEJRAL, J., FIALA, Z., BENCKO, V., ŠMEJKALOVÁ, J., SRB, V., TMĚJOVÁ, M., BORSKÁ, L., ANDRÝS, C., KUČERA, J., Health status of persons occupationally exposed to chromium, nickel, manganese and polycyclic aromatic hydrocarbons, *Acta Medica (Hradec Králové)* **42**(Suppl.) (1999) 65–69 (in Czech).

- [27] HANOVCOVÁ, I., CHÝLKOVÁ, V., TEJRAL, J., ANDRÝS, C., PROCHÁZKOVÁ, J., TURKOVÁ, M., SRB, V., ETTLEROVÁ, E., KOKOŠ, J., Long-term monitoring of the immune reactivity of stainless steel welders, *Cent. Eur. J. Publ. Hlth.* **6** (1998) 51–56.
- [28] ULRICH, L., MORAVÍK, J., MIŠKOVIČ, P., KLEMENT, C., MALÍK, E., VLADÁR, M., Relationship between exposure to metals and immunological changes in welders, *Prac. Lék.* **42** (1990) 147–151.

# INTERLABORATORY COMPARISON SURVEY OF THE DETERMINATION OF CHROMIUM, MANGANESE, IRON, TITANIUM IN WELDING DUST AND ARSENIC, CADMIUM, COBALT AND CHROMIUM IN URINE

J.M. CHRISTENSEN

National Environmental Research Institute, Roskilde, Denmark

## Abstract

This report describes an interlaboratory comparisons based on the Danish External Quality Assessment Scheme (DEQAS). The first study was carried out in 1998 for 8 laboratories in the CRP research project on assessment of levels and health effects of airborne particulate matter in mining, metal refining and metal working industries using nuclear and related analytical techniques. The results showed that the deviations from the target values appear to be systematic, as the deviations for Mn, Fe, Ti in welding dust as well as for As, Cd, Co and Cr in urine were a linear function of the target values (ISO 5725 evaluation). The cause for this bias was unknown. Therefore, validation of the methodologies and a second intercomparison survey were suggested for determination of As, Cd, Co and Cr in urine. The second intercomparison survey was carried out in year 2000 for 6 laboratories measuring biological materials. Four laboratories measured arsenic (As), cadmium (Cd), cobalt (Co) and five laboratories measured chromium (Cr) in urine. The target values of the quality control materials were traceable to certified reference materials. For evaluating the analytical performance the Z-score and  $E_n$  number were calculated as recommended in ISO 45. The judgement of laboratories according to the performance scores revealed that no laboratories could maintain an ideal  $E_n$  number below 3 for all components. Nearly all participants had a high precision in the reported results. The deviations from the target values appear to be systematic, because the deviations for Mn, Fe, Ti in welding dust as well as for all laboratories urinary As and Cd results deviated from the target values. Two laboratories had acceptable results for urinary Co and one laboratory for Cr at all three concentration levels. The observed bias appears to be systematic, because the deviations for As, Cd, Co and Cr in urine were a linear function of the target values (ISO 5725 evaluation). Compared to the first intercomparison survey the analytical performance of As, Cd, Co and Cr in urine have improved considerably.

## 1. INTRODUCTION

For measurement data to be sound and reliable they must be obtained under a good quality assurance system including internal and external quality control [1, 2]. The global acceptance of the *Guide to expression of uncertainty in measurement* (GUM) has attracted attention to the need for controlling measurement results [3, 4]. In order to achieve this objective it is recommended to report the uncertainty of measurement results, and whenever possible, to participate in External Quality Assessment Schemes (EQAS).

Although there are several types of schemes, they all share the common feature of comparison of a laboratory's results with those of other laboratories. EQAS are used to determine the performance of individual laboratories for specific measurements, and to monitor the continuing performance of laboratories described by laboratory bias, stability, repeatability and traceability as described in ISO 5725 [5–7].

Commonly used statistics for quantitative results in EQAS are the deviation of the participants result from the assigned (target) value, and Z-score, which is the difference between the participants results and the assigned value divided by an estimate of variability. A value of  $|Z| \leq 3$  is satisfactory [8]. ISO 43 recommends calculating the  $E_n$  number, which

is the difference between the participants result and the assigned value divided by the squared sum of the uncertainty of the participants result and the uncertainty of the assigned value. A value of  $|E_n| < 1$  is satisfactory [8, 9].

The Danish External Quality Assessment Scheme (DEQAS) is developed and managed by the National Institute of Occupational Health (Arbejdsmiljøinstituttet, AMI) in Denmark. It is designed to evaluate the quality of results of measurements of a group of laboratories [10]. This paper presents a summary of the results of the first intercomparison study completed in 1998 and the results of the second intercomparison survey on arsenic, cadmium, cobalt and chromium in urine carried out in 2000. The participants in the IAEA-DEQAS's are the contractors of the IAEA coordinated research project on assessment of levels and health effects of airborne particulate matters in mining, metal refining and metal working industries using nuclear and related analytical techniques.

## 2. METHODS

### 2.1. Danish external quality assessment schemes

The Danish EQAS is designed to ensure a homogenous quality of workplace measurements. The individual laboratory is evaluated on the basis of reference values (target values) or consensus values calculated on the basis of all observations obtained after statistical rejection of outliers. In the first interlaboratory comparison exercises the participating laboratories received one sample for analysis of Cr in welding dust, three samples for analysis of Mn, Fe and Ti in welding dust, and three samples for analysis of As, Cd, Co and Cr in urine. In the second intercomparison exercises the participants received six samples for analysis of As, Cd, Co and Cr in urine (three samples times two at the same concentration levels). The target values were at three different concentrations and identical in the two intercomparison exercises. Each laboratory received sheets for reporting the results and the analytical techniques.

### 2.2. Quality control samples and distribution

The preparation of the filters loaded with welding dust for analysis of manganese, iron and titanium and filters (borosilicate microfibre glass discs without resin binder) loaded with Cr have previously been described [11]. The chromium concentration in the control material is traceable to the Community Bureau of Reference BCR certified reference material CRM 545 [12].

For both intercomparison exercises the urine was obtained from normal healthy donors. Samples at three different concentrations were produced, low level (baseline level), medium level (spiking of standard solution) and high level (spiking of standard solution), respectively. Spiking solutions were prepared using dimethylarsinic acid (SIGMA C 0250, 98% pure), Cd atomic absorption standard solution (SIGMA C 5524, 1000  $\mu\text{g Cd/L}$ ), Cr atomic absorption standard solution (SIGMA C 5899, 1005  $\mu\text{g Cr/L}$ ) and Co atomic absorption standard solution (SIGMA C 7405, 970  $\mu\text{g Co/L}$ ). The materials were spiked as described in Table I.

TABLE I: TARGET VALUES AND SPIKING AMOUNTS FOR AS, CO, CD AND CR IN LOW, MEDIUM AND HIGH QUALITY CONTROL MATERIALS.

Quality control material	Arsenic		Cobalt		Cadmium		Chromium	
	Target $\mu\text{g As/L}$	Spike $\mu\text{g As/L}$	Target $\mu\text{g Co/L}$	Spike $\mu\text{g Co/L}$	Target $\mu\text{g Cd/L}$	Spike $\mu\text{g Cd/L}$	Target $\mu\text{g Cr/L}$	Spike $\mu\text{g Cr/L}$
Low	23.45	0	0.31	0	0.20	0	1.47	0
Medium	75.75	50	10.43	10	5.2	5	6.4	5
High	157	150	61.7	60	10.1	10	20.95	20

Each vial contained 10 ml of lyophilised urine, homogenous and easy to reconstitute in 10.00 ml purified water. The target values of the urine materials are traceable to the Community Bureau of Reference (BCR), draft certified reference material CRM 640, 641, 642 [13]. The samples were delivered to IAEA, Vienna, which distributed the materials to each laboratory.

### 2.3. Participants

In the first intercomparison survey the samples for Cr, Mn, Fe, Ti in welding fume dust were analysed by 8 laboratories, and samples for As, Cd, Co and Cr in urine were analysed by 6, 4, 5 and 4 laboratories, respectively. In the second intercomparison survey the samples for As, Cd, Co and Cr in urine were analysed by 6 laboratories. The participating laboratories are listed in the acknowledgement, and the analytical techniques used by the laboratories are described in Annex 1.

### 2.4. Statistical model

The main theory is based on the assumption that the analytical method should be in statistical control for all concentrations during the period of analysis, i.e. the results of independent measurements of samples with the same reference value  $\mu$  are approximately normally distributed (Gaussian distribution). Both the mean value  $\mu_i$  of the measured metal concentration  $E(Y | \mu)$  and the experimental standard deviation  $\sigma_i$  may be a function of  $\mu$ . The bias of the analytical method is defined by  $\delta_i = E(Y | \mu) - \mu$ . Kolomogorov-Smirnov test for goodness of fit to the normal distribution is carried out and Cochran and Grubbs outlier tests are used to identify and exclude outliers [10].

### 2.5. Target values

The target values were established as target values obtained in certification intercomparison studies (Cr in welding fumes dust, As, Cd, Co and Cr in urine) [12, 13]. Consensus mean values, which are the mean values of the results of several DEQAS rounds after outliers exclusion and results obtained by reference laboratories, were established for Mn, Fe and Ti in welding fume dust.



## 2.6. The method evaluation function

The analytical results were evaluated in relation to the target values. Estimates of the experimental standard deviation of the method used by the laboratories, the slope ( $\hat{a}$ ) and the intercept ( $\hat{a}$ ) of the regression line were obtained by statistical evaluation (least square regression analysis) of the linear relationship between the results obtained by the laboratory and the target values [6, 7]. The ideal method evaluation function (MEF) is given by the intercept ( $\hat{a}$ ) and the slope ( $\hat{a}$ ) equal to 0.0 and 1.0, respectively [10, 15].

## 2.7. Calculation of the performance statistics

Commonly used performance statistics are the percentage deviation from the target value, the relative standard deviation and the Z-score.  $Z = (x-X)/s$ , where  $x$  is the participants result,  $X$  is the target value, and  $s$  is the standard uncertainty specified by the laboratory. Values of  $|Z| > 3$  may with great confidence be considered due to poor performance.  $E_n$  numbers are used in measurement intercomparison schemes, i.e.  $E_n = |(x-X)| / (u_{lab}^2 + u_{ref}^2)^{1/2}$ ,  $u_{lab}$  is the uncertainty of a participant's results and  $u_{ref}$  is the uncertainty of the target value established by reference laboratories. Values of  $E_n < 3$  is satisfactory [8].

## 3. RESULTS AND DISCUSSION

### 3.1. Chromium in welding dust loaded on filters

The participants were requested to report two results for each sample. Figure 1 displays a bar-plot of the obtained values and the uncertainties. The lines indicate the target value and the uncertainty of the target value, 2 and 3 standard deviations, respectively. Only Lab. 55 and Lab. 58 reported acceptable results.

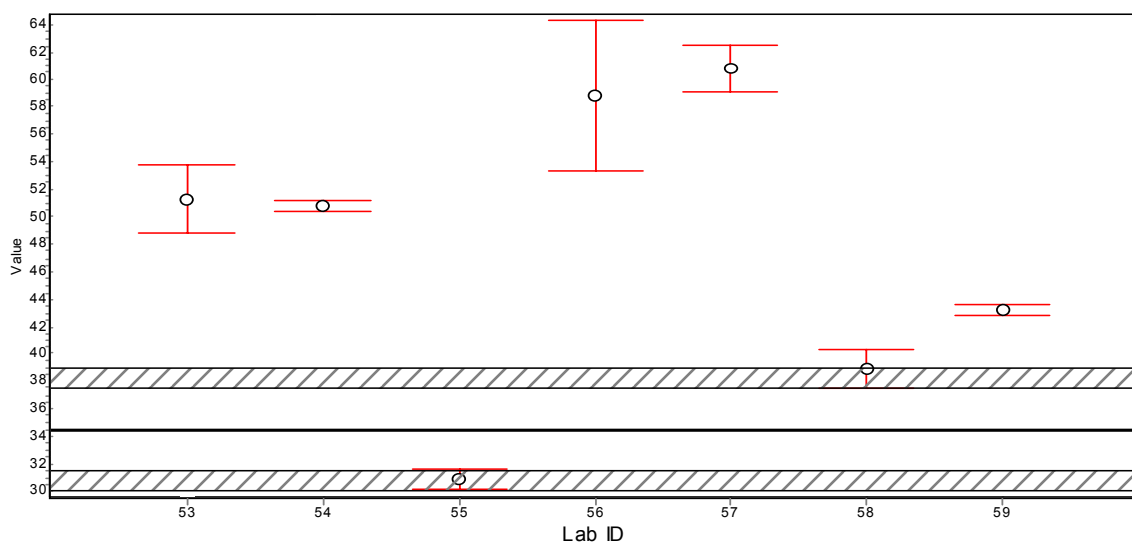

FIG. 1. Bar-plot of the obtained values of Cr. Values is in mg/kg dust. The lines indicate the uncertainty of the target value, 2 and 3 standard deviations, respectively.

### 3.2. Manganese, iron and titanium in welding fumes loaded on filters

The participants were requested to report two results for each filter at three different concentration levels. Figure 2 displays a bar-plot of the obtained values for manganese at low level and the uncertainties. The lines in Figure 2 indicate the target value and the uncertainty of the target value, 2 and 3 standard deviations, respectively. Lab. 53, 54, 56, 58 and 59 reported acceptable results.

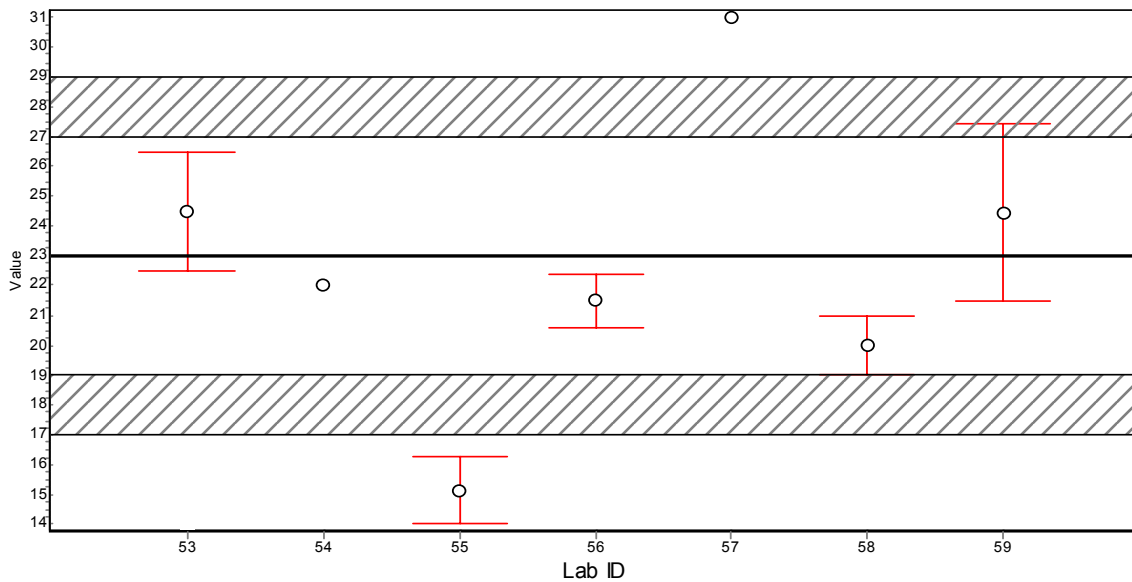

FIG. 2. Bar-plot of the obtained values of Mn in welding fume dust. Values in µg/filter.

Figure 3 displays a bar-plot of the obtained values for iron and the uncertainties. The lines in Figure 3 indicate target value and the uncertainty of the target value, 2 and 3 standard deviations, respectively. Lab. 53, 54, 56, and 59 show acceptable results.

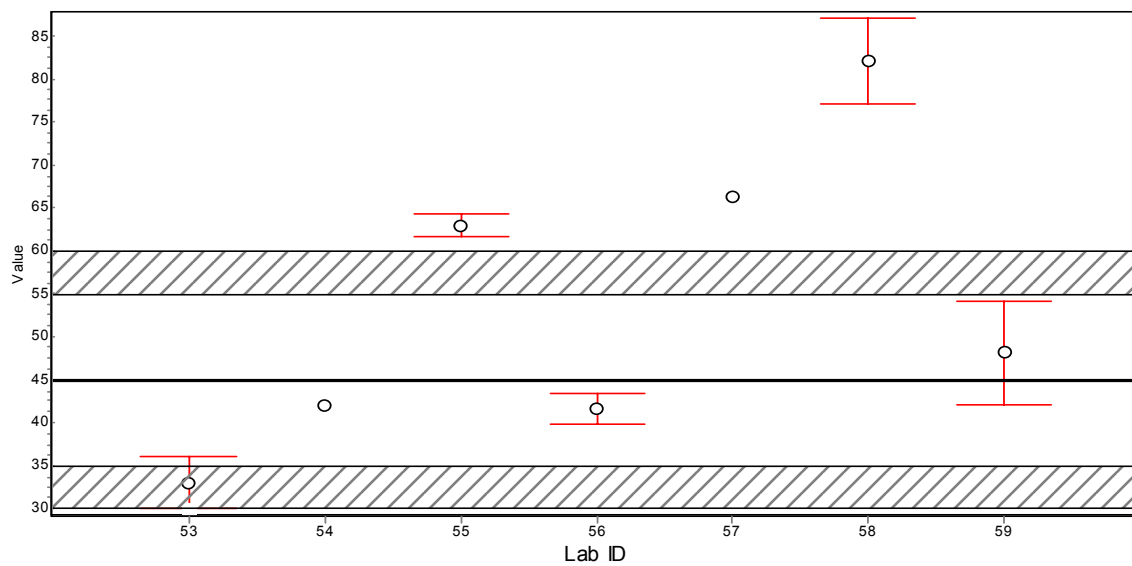

FIG. 3. Bar-plot of the obtained values of iron in welding fume dust. Values in µg/filter.

Figure 4 displays a bar-plot of the obtained values for titanium and the uncertainties. The lines in Figure 4 indicate the target value and the uncertainty of the target value, 2 and 3 standard deviations, respectively. Lab. 53, 55, 56 and 59 reported acceptable results.

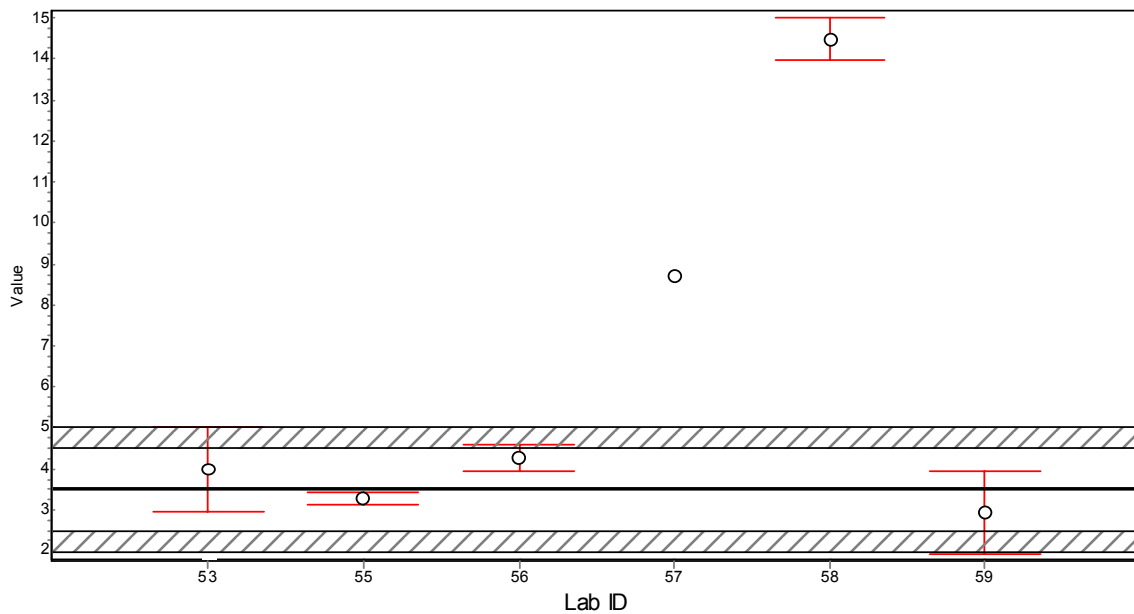

FIG. 4. Bar-plot of the obtained values of Ti in welding fume dust. Values in µg /filter.

### 3.3. Arsenic, cadmium, cobalt and chromium in urine

The participants were requested to report two results for urine samples at three different concentration levels. Figure 5 shows results of arsenic in urine from the evaluation report. The Figure displays a bar-plot of the obtained values for arsenic at low level, and the uncertainties. The lines in Figure 5 indicate the target value and the uncertainty of the target value, 2 and 3 standard deviations, respectively.

No laboratories have acceptable arsenic results at low level. Lab. 1, 2 and 3 (high level) and Lab. 1 and 3 (medium level) have acceptable results.

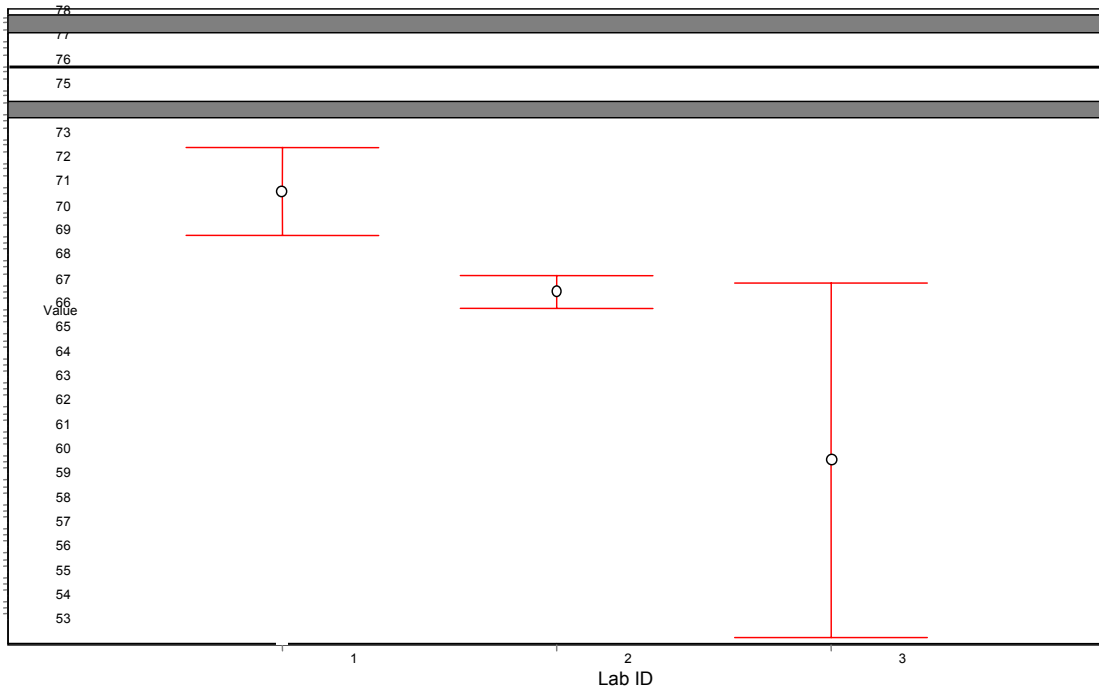

FIG. 5. Bar-plot of the obtained values of As in urine ( $\mu\text{g/L}$ ) at target value  $75.75 \mu\text{g/L}$ .

Figure 6 displays a bar-plot of the obtained values for cadmium at medium level in urine and the uncertainties. The lines in Figure 6 indicate the target value and the uncertainty of the target value, 2 and 3 standard deviations, respectively. None of the laboratories reported acceptable results for all three levels. For cadmium at medium level lab 1 and 2 had acceptable levels.

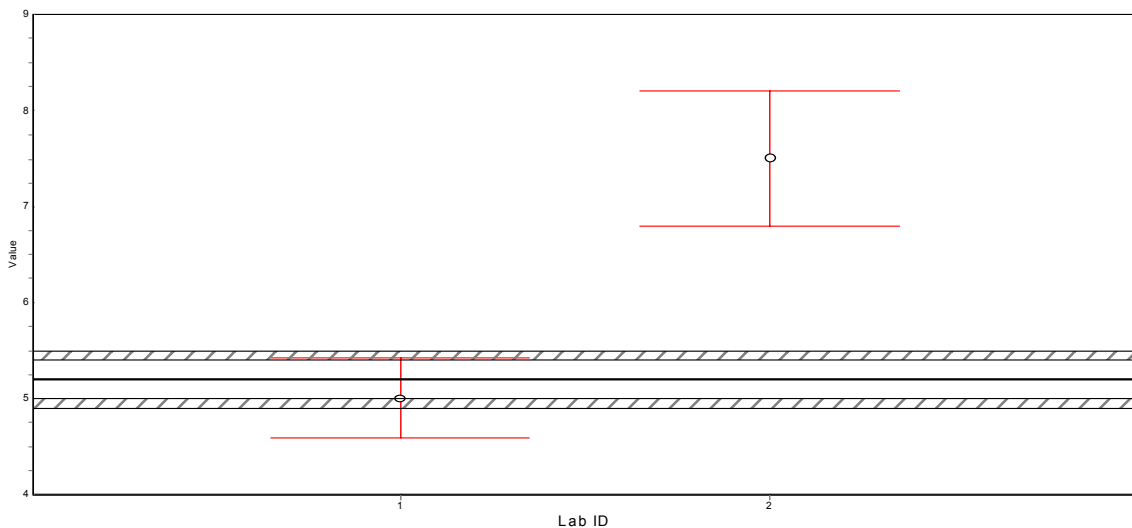

FIG. 6. Bar-plot of the obtained values of Cd in urine ( $\mu\text{g/L}$ ) at target value  $5.20 \mu\text{g/L}$ .

Figure 7 shows results of cobalt in urine from the evaluation report. The Figure displays a bar-plot of the obtained values for cobalt at high level and the uncertainties. The lines in Figure 7 indicate the target value and the uncertainty of the target value, 2 and 3 standard deviations, respectively. Only Lab. 3 reported acceptable results at all three levels.

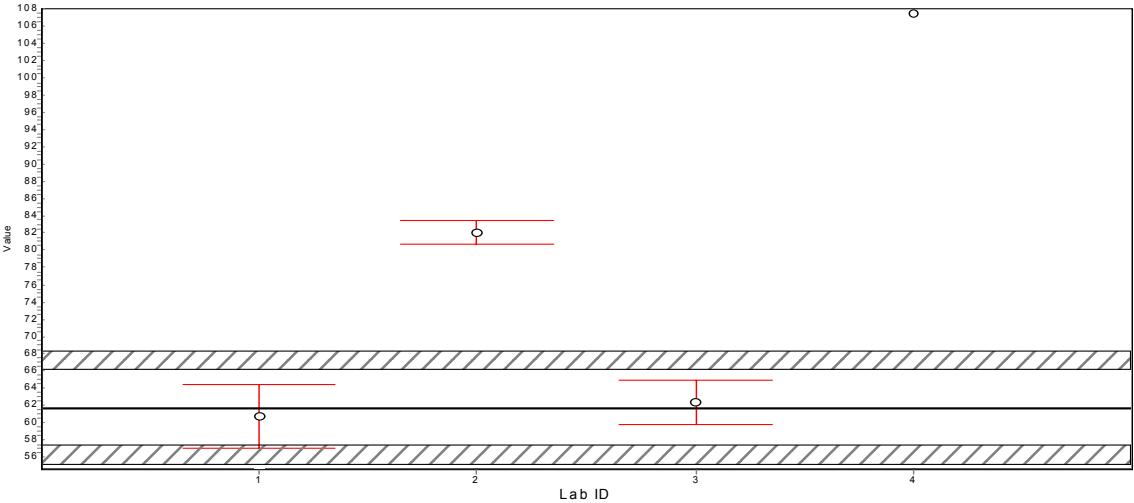

FIG. 7. Bar-plot of the obtained values of Co in urine (µg/L) at target value 61.70 µg/L.

Figure 8 shows results of chromium in urine from the evaluation report. The Figure displays a bar-plot of the obtained values for chromium at high level and the uncertainties. The lines in Figure 8 indicate the target value and the standard uncertainty of the target value, 2 and 3 standard deviations, respectively. At the three levels only Lab. 5 reported acceptable analytical performance. At chromium high level (20.95 µg/L) lab 1, 3, 4 and 5 demonstrated acceptable results.

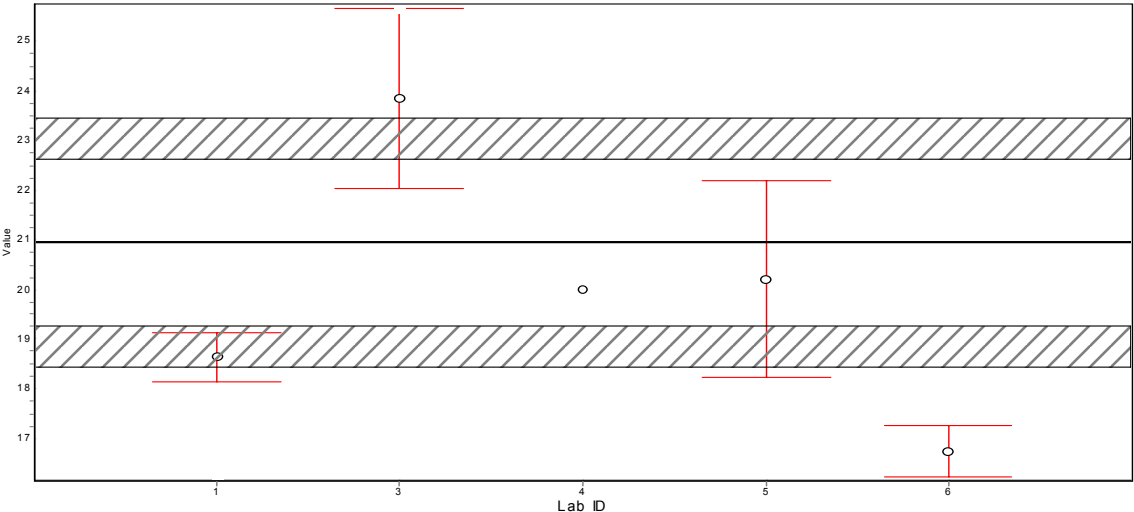

FIG.8. Bar-plot of the obtained values of Cr in urine (µg/L) at target value 20.95 µg/L.

The regression results indicate that the laboratories may have contamination or calibration errors for arsenic, cadmium and chromium because all of the obtained results at the three concentration levels show a linear functional relationship. However, a history plot of the Z-scores for As, Cd, Co, and Cr in urine showed that compared to the first intercomparison survey the analytical performance has been improved. [16].

#### 4. CONCLUSION

In the first interlaboratory comparison study in 1998 seven laboratories reported results for chromium in welding fume dust loaded on filters. Observations deviating as much as 76% from the target value were seen for a single laboratory. Two laboratories had acceptable performance scores for Cr in welding dust.

Seven laboratories reported results for manganese, iron and titanium in welding fume dust loaded on filters. Observations deviating as much as 479% from the target value were seen for titanium, but in general the results for manganese and iron were acceptable.

Six laboratories reported results for arsenic in urine, four laboratories reported results for cadmium, and five laboratories reported results for cobalt and chromium in urine. Observations deviating as much as 3640% from the target value were observed for arsenic in urine. For cobalt and chromium in urine none of the laboratories reported results of acceptable analytical performance.

In the second intercomparison study four laboratories reported results for arsenic, cadmium and cobalt and five chromium in urine. For arsenic and cadmium in urine no laboratories reported results of acceptable analytical performance at all three levels. For chromium in urine two of the laboratories reported results of acceptable analytical performance at all three levels. For cobalt in urine only one of the laboratories reported results of acceptable analytical performance at all three levels. Nearly all participants had a high precision in the reported results. The deviations from the target values appear to be systematic, because the deviations were a linear function of the target value (ISO 5725 evaluation). The cause for the bias is unknown at present and might not be the same for all participants. Compared to the first intercomparison survey the analytical performance has improved considerably.

#### ACKNOWLEDGEMENT

The project was carried out under Contracts DEN-10024 and 10979/R0-2000 funded by IAEA and coordinated by Reference laboratory, National Institute of Occupational Health, Denmark. The following laboratories participated in the intercomparison study:

- Department of Nuclear Analysis, Institute of High Energy Physics, Beijing, China.
- Supervisao de Reator e Radioanalise, Centro de Desenvolvimento da Tecnologia Nucl., Belo Horizonte, Minas Gerais, Brazil.
- Health Physics Unit, Indian Rare Earths Limited, Udyogamandal, Kerala State, India
- Institute for Nuclear Science, College of Engineering, University of Nairobi, Kenya
- Physics Department, Nuclear and Technological Institute, Estrada Nacional, Sacavem, Portugal

- Depart. of Activation Analysis and Radiation Research, Frank Laboratory of Neutron Physics, Joint Inst. for Nuclear Research, Dubna, Moscow Region, Russian Federation
- Laboratory for Radiochemistry, Department of Environmental Sciences, Institut Jozef Stefan, Ljubljana, Slovenia.
- Nuclear Spectroscopy department, Nuclear Physics Institute, Academy of Science of the Czech Republic, Czech Republic.

## REFERENCES

- [1] CHRISTENSEN, J.M., POULSEN, O.M., ANGLOV, T., Method evaluation, quality control and external quality assurance systems of analytical procedures. In: Handbook on metals in clinical chemistry, Seiler, H.G., Sigel, A. & Sigel, H. (Eds). Marcel Dekker, New York (1994) 45–63.
- [2] CHRISTENSEN, J.M., Human Exposure to Toxic Metals. Factors Influencing Interpretation of Biomonitoring, *Sci. Tot. Environ.* **166** (1995) 89–135.
- [3] INTERNATIONAL ORGANIZATION FOR STANDARDIZATION, Guide to expression to uncertainty in measurement (GUM), Geneva (1995).
- [4] KRISTIANSEN, J., CHRISTENSEN, J.M., Traceability and uncertainty in analytical measurements, *Ann. Clin. Biochem.* **35** (1998) 371–379.
- [5] INTERNATIONAL ORGANIZATION FOR STANDARDIZATION, Accuracy (trueness and precision) of measurement methods and results, Part 2: Basic method for the determination of repeatability and reproducibility of a standard measurement method. Basic methods for estimating the trueness of a test method, ISO, Geneva (ISO/IEC Standard 5725).
- [6] INTERNATIONAL ORGANIZATION FOR STANDARDIZATION, Accuracy (trueness and precision) of measurement methods and results, Part 4: Basic methods for the determination of the trueness of a standard measurement method. Basic methods for estimating the trueness of a test method, ISO, Geneva (ISO/IEC Standard 5725).
- [7] INTERNATIONAL ORGANIZATION FOR STANDARDIZATION, Accuracy (trueness and precision) of measurement methods and results, Part 5: Alternative methods for the determination of the precision of a standard measurement method, Geneva (ISO/IEC Standard 5725).
- [8] INTERNATIONAL ORGANIZATION FOR STANDARDIZATION, Guide 43, Proficiency testing by interlaboratory comparisons, Part 1: Development and operation of proficiency testing schemes. Part 2: Selection and use of proficiency testing schemes by laboratory accreditation bodies, (ISO/IEC Guide 43), Geneva (1996).
- [9] Draft ISO 13528: The statistical methods to analyse the data obtained from proficiency testing schemes and guidance on actions to take: Statistical methods for use in proficiency testing by interlaboratory comparisons (1999).
- [10] ANGLOV, T., HOLST, E., CHRISTENSEN, J.M., Danish External Quality Assessment Scheme: an interlaboratory comparison study on lead, cadmium and chromium in lyophilised human blood concentrate, *Occup. Environ. Health* **64** (1993) 431–438.
- [11] NAHRES-59, Vienna 2000, Report on the second research coordinating meeting (1999) 53–77.
- [12] CHRISTENSEN, J.M., BYRIALSEN, K., VERCOUNTERE, K., CORNELIS, R., QUEVAUVILLER, P., Certification of Cr (VI) and total leachable Cr contents in welding dust loaded on a filter (CRM 545), *Fres. J. Anal. Chem.* **363** (1999) 28–32.

- [13] BYRIALSEN, K., CHRISTENSEN, J.M., DIRSCHERL, S., The certification of the contents of trace elements and a metabolite in urine, CRM 640, CRM 541, CRM 642. Draft certifications report (2001).
- [14] INTERNATIONAL UNION OF PURE AND APPLIED CHEMISTRY, Protocol for the design, conduct and interpretation of collaborative studies, Pure and Appl.Chem. **60** (1988) 856–864.
- [15] CHRISTENSEN, J.M., POULSEN, O.M., ANGLOV, T., Protocol for the design and interpretation of method evaluation in AAS analysis, Application to the determination of lead and manganese in blood, J. Anal. Atomic. Spec. **7** (1992) 329–224.
- [16] CHRISTENSEN, J.M., BYRIALSEN, K., Proficiency testing in occupational and environmental health — current practice and international initiatives for harmonisation, Accred. Qual. Assur. (2001).

## ANNEX 1

Summary of the analytical techniques used in the intercomparison comparison surveys:

In the first intercomparison instrumental NAA was used for the determination of Mn, Cr, Fe, Ti in welding fumes. Radiochemical NAA for As and Co in urine (Lab. 54).

XRF was used for determination of Fe, Mn and Ti. Standard samples were obtained from IAEA. ICP-AES was used for quantification of Cr (VI). The filter was dissolved in conc. HNO<sub>3</sub>. The organic matter was destroyed by HNO<sub>3</sub>–HClO<sub>4</sub> mixture and dissolved in 1 M HNO<sub>3</sub>. ICP-MS was used for the determination of Cd in urine. Internal standard was Rh/Ru. Samples were destroyed in 10 ml distilled water and evaporated to dryness. Afterwards the material was treated with 5 ml HNO<sub>3</sub> and 1 ml HClO<sub>4</sub>. The residue was dissolved in 1M HCl (Lab. 55).

PIXE technique was used for quantification of elements without any sample pre-treatment. The concentration was obtained in mg/cm<sup>3</sup> for the filter samples and results were calculated to mg/kg dust for Cr and µg/filter for Ti, Mn and Fe, respectively. The urine samples were reconstituted and lyophilised. There were problems with the freeze-dryer. The recovered material was too small to obtain enough sub-sample for analyses (Lab. 56).

Energy dispersive X ray fluorescence spectrometry without any pre-treatment of filters was used for the determination of Cr, Mn, Fe and Ti in welding fumes dust on filters. For analysis of As, Cr and Co in urine about 0.1 g of the lyophilised urine materials were weighed and dissolved in 1 ml nickel standard solution. The instrumental equipment used for quantification was total reflection X ray fluorescence spectrometry (Lab. 57).

Sample preparation was not carried out for determination of Fe, Ti, Mn, and Cr. The instrumental technique was vacuum sequential X ray spectrometry. All urine samples were determined by FAAS. As in urine was determined by FAAS with hydride generation. Cd was determined using on-line FAAS with pre-concentration. Urine samples were dissolved in conc. HNO<sub>3</sub>/HClO<sub>4</sub> heated and dissolved in 2M HNO<sub>3</sub> (Lab. 58).

Instrumental NAA was used for determination of elements on filters, which were palletised with a manual press. Filters for Cr (VI) determination were dissolved in conc. HNO<sub>3</sub> and analysed by AAS. As alternative technique energy dispersive X ray fluorescence



spectrometry was performed directly on the filters. For Cd determination in urine instrumental NAA and total XRF were used, but the results show that this technique is not sufficiently sensitive for such samples. Urine results were reported in  $\mu\text{g/g}$  dry material and then calculated to  $\mu\text{g/L}$  urine (Lab.59).

Instrumental NAA were used for determination of Mn, Ti, Cr and Fe. Radiochemical NAA was not applied. None sample pre-treatment was performed except for heat-sealing into polyethylene irradiation vials prior to irradiation (Lab. 60).

In the second survey AAS and ICP-AES were used for analysis of As, Cr and Co in urine (Lab 1, corresponds to Lab 53 in the first survey). Part of the samples was checked by ICP-MS.

For Co and Cd determination in urine instrumental NAA and was used (Lab 2, corresponds to Lab 58 in the first survey) and AAS hydride generation was used to determine As. Samples were reconstituted by adding 10 ml of distilled water and 1–1.5 ml urine was placed on cellulose substrate.

Instrumental NAA were used for As, Cd, Cr and Co in urine (Lab. 3 corresponds to Lab 59 in the first survey). For sample preparation 10 ml of pure water was added to lyophilised urine at room temperature and homogenised. 2 ml from each sample was taken and irradiated for 20 hours at the TRIGA MARK II reactor.

Flame AAS was used for the determination of Cd, Co and Cr in urine (Lab 4 corresponds to Lab 57 in the first survey). Samples were reconstituted by adding 10 ml of distilled water and thereafter shaking for one hour. XRF was used to determine As Cr and Co in urine (Lab 4, corresponds to Lab 57 in the first survey). Samples were reconstituted by adding 10 ml of distilled water. The solution was transferred into 250-ml beakers and each sample diluted ten times to make 100 ml each. The pH of the solution was adjusted to between 3.5 and 4 and 10 ml of freshly prepared 1% APDC added. The solutions were stirred for 30 minutes. The precipitates formed were then filtered through a nucleopore filter membrane of 0.4  $\mu\text{m}$  pore diameter, dried by air and directly analysed by energy dispersive XRF.

As, Cd, Cr, Co in urine was determined by ICP-AES without any pre-treatment (Lab 6 corresponds to Lab 54 in the first survey). In order to avoid missing values in the statistical analysis results below the limit of detection are presented as the limit of detection divided by two.

- XRF X ray fluorescence spectrometry
- NAA Neutron activation analysis
- INAA Radiochemical instrumental neutron activation analysis
- ICP-AES Inductively coupled plasma atomic emission spectrometry
- ICP-MS Inductively coupled plasma mass spectrometry
- PIXE Proton induced X ray emission
- FAAS Flow injection atomic absorption spectrometry
- AAS Atomic absorption spectrometry

# TECHNICAL SUPPORT FOR IMPROVED WORKPLACE MONITORING SOLID AEROSOLS WITH SPECIAL ATTENTION TO DUST CONTAINING TOXIC TRACE ELEMENTS

E. OLSEN<sup>1</sup>, M.E. NYELAND<sup>1</sup>, J.M. CHRISTENSEN<sup>2</sup>

<sup>1</sup> National Institute of Occupational Health, Copenhagen, Denmark

<sup>2</sup> National Environmental Research Institute, Roskilde, Denmark

## Abstract

The aim is to contribute to an improvement of measuring airborne particle, especially in the Third World, by reviewing the literature on particle behaviour in air of the workplace and in the human airways, the sampling theory for aerosols, and sampling equipment, which is currently in use and commercial available. The concepts and equations are given, which are necessary for understanding the often counter-intuitive behaviour of aerosols in the occupational setting and elsewhere. The mathematical manipulations of the equations have been kept at a minimum; instead transport properties are illustrated by a series of calculations for aerosols consisting of water, minerals, and uranium.

The same concepts and equations are needed to explain and quantify the deposition of particle in the human airways and to design measurement devices. These devices are used for measuring the different aerosol fractions, which will deposit in different parts of the human airways. A brief description of the human airways is given, which is adequate for the understanding of particles' deposition. The human airways are divided into the extrathoracic, the thoracic, and the alveolar compartment. The Inhalable, the Thoracic, and the Alveoli Fractions of an aerosol are those fractions, which will penetrate into the extrathoracic, the thoracic, and the alveolar compartments.

The available methods for collecting airborne particles are described and it is discussed to what extent each type of equipment is sampling the aerosol fraction of interest.

## 1. INTRODUCTION

Humans are exposed to airborne solid particles (solid aerosols) in the ambient environment and at work. Workers are exposed, e.g. in mines during stripping, crushing, grinding, and milling, during transport of the minerals excavated, in work-places where the minerals are worked-up to the pure elements, compounds or alloys.

The aerosol fractions are measured using the corresponding Inhalable, Thoracic, and Alveoli (or Respirable) Conventions given in the international standards on sampling of airborne particles: EN481 (1993) [1]. No single piece of equipment can measure all types of aerosol, however, some aerosol samplers have proven to be very close to sample in accordance with the convention given in EN481 (1993).

Workers working in underground mines are in addition to exposure to airborne dust exposed to a variety of other pollutants, this includes the gases CO, CO<sub>2</sub>, NO, NO<sub>2</sub>, SO<sub>2</sub>, diesel exhaust aerosols, and a variety of aerosol-associated gas-phase hydrocarbons. More than 90% by mass of the diesel exhaust particles have aerodynamic diameters less than 0.1 µm [2].

The Mine Safety and Health Administration regulates total dust, quartz, radon daughters, asbestos, and welding fumes (MSHA, 1990).

Airborne particles are encountered at the workplace as aggregates or agglomerates. A class of solid aerosols of special interest is airborne particles containing toxic trace elements, which may accumulate in the human body. Solid aerosols are practically never consisting of

particles of the same size. In contrast, they usually consist of particles, the sizes of which are widely varying. The size distribution depends on how the particles originally were created and on the history of the particles since their creation.

If particles are inhaled, the size, form, and density of the particles determine where in the human airways they will be deposited. The objective of sampling airborne particles, therefore, is to collect the fractions, which are deposited in different parts of the human airways.

## 2. OBJECTIVE

The objective is to review the literature on sampling methods for airborne particles, with special emphasis on particles containing toxic trace elements. The report should take into consideration conditions prevailing in the Third World.

## 3. BEHAVIOUR OF AIRBORNE PARTICLES

The size, form, and density determine the transport properties of particles in air. For understanding human exposure to airborne aerosols and the disposition of particles in the human airways, knowledge is needed about the inhaled particles' transport properties, the speed at which the exposed human is breathing, and on how the human airways are built. The same knowledge is needed to measure exposure correctly.

### 3.1. Aerosols

#### 3.1.1. *Dust*

Dust is an aerosol consisting of solid particles created by mechanical means, for instance during cutting, crushing, abrasion, grinding, milling done by man, or animals activities, or the nature in general. Dust exists in many sizes. Small dust particles may penetrate as far as the alveoli. Fibers are a subcategory of dust, which also may penetrate into the alveoli even they may be of a considerable length.

#### 3.1.2. *Liquid aerosols*

A mist is an aerosol of liquid droplets produced by condensation. Droplet sizes are up to a few micrometers [3]. Droplets produced by atomization are generally greater than 5  $\mu\text{m}$  [4].

#### 3.1.3. *Fumes*

Fumes are aerosols consisting of solid particles produced by condensation of vapours or gaseous combustion products. Usually they are found as aggregates less than one  $\mu\text{m}$  consisting of primary particles of a few nanometers. Current interest in atmospheric pollution studies has focused on solid particles in the size range below 2.5  $\mu\text{m}$ , with a finding that they tend to be the fraction formed by gas phase reactions in the atmosphere. Their prevalence can be correlated with specific health effects [4]. At the workplace fumes are created during welding and soldering.

### 3.1.4. Smokes and soot

Smoke is an aerosol of solid particles resulting from incomplete combustion. The sizes of smoke particles are usually less than 0.5  $\mu\text{m}$ .

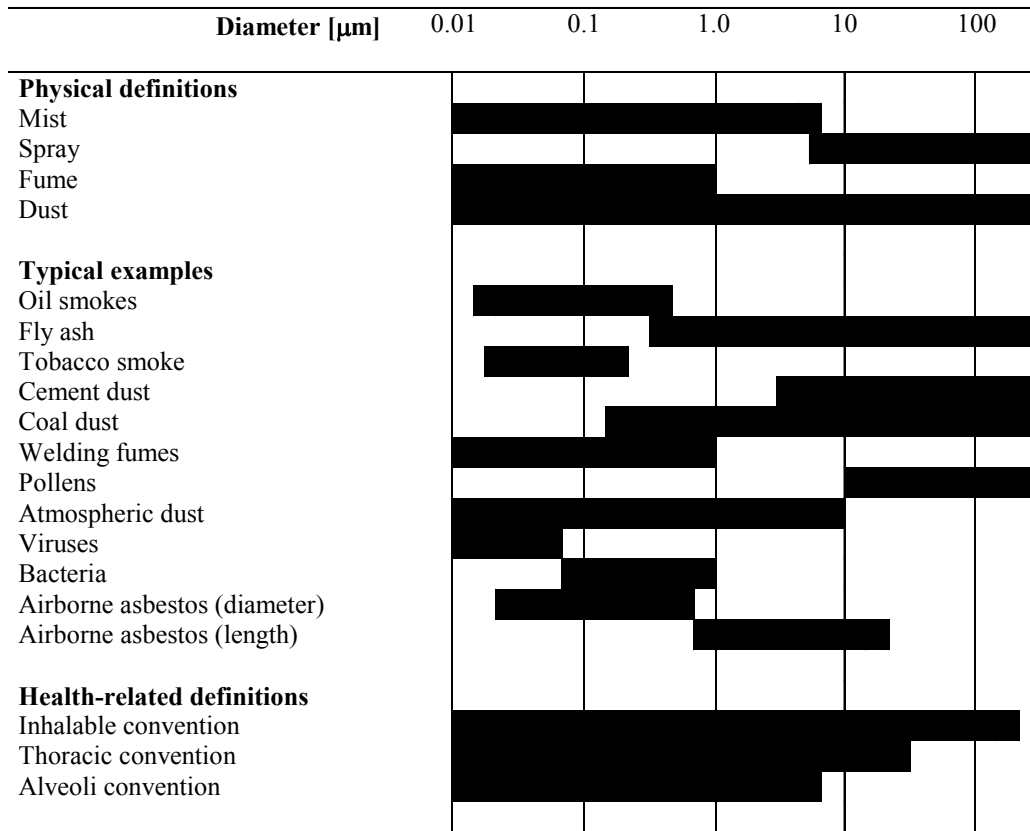

FIG. 1. Particle sizes of some aerosols (after Ref. [5], [3], [6]).

## 3.2. Drag forces

### 3.2.1. Stoke's Law

Stokes law: the drag force acting on a airborne spherical particle is proportional to the particles diameter, proportional to its velocity, and proportional to the viscosity of the fluid, i.e. the air ( $\mu_{Air} = 1.81 \times 10^{-5} \text{ Pa}\cdot\text{s}$ ):

$$F_{Drag} = -3 \pi d_p \mu_{Air} v_p \quad (1)$$

The minus sign indicates that the drag and the velocity are in opposite directions.

To understand flows, the Reynold's number is central. Reynold's number, usually denoted  $Re$  is given by:

$$Re = d v \rho_p / \mu_{Air} \quad (2)$$

where  $d$  is a characteristic length,  $\mu_{Air}$  is the air viscosity, and  $\rho_p$  is the density of the particle [ $\text{kg}\cdot\text{m}^{-3}$ ].

### 3.2.2. Deviations from Stoke's law

Particles, however, fall sometimes slower than calculated using Stoke's law. Stoke's law, therefore, should be modified by three factors correcting for:

- Slip.
- Non-Stokesian flow for  $Re \geq 1$ .
- Non-spherical particle shape.

#### 3.2.2.1. Slip

Air surrounding the particle is not a continuum, but is made up of gas molecules, which are in continuous random motion caused by temperature. For particle with diameters smaller than the mean free path experience the slip phenomenon. The mean free path (mfp) is the mean distance a particle passes before it collides with another particle or an air molecule.

For particles, which are so small that  $d_p$  is of the same order of magnitude as the mean free path of the air molecules will experience a slip, which can be corrected for by the Cunningham slip correction factor  $C_{Slip}(d)$  [7]:

$$F_{Drag} = -3 \pi d_p \mu_{Air} v_p / C_{Slip}(d) \quad (3)$$

$$C_{Slip}(d) = 1 + (mfp/d)(2.34 + 1.05 \exp(-0.39 d/mfp)) \quad (4)$$

Where  $mfp$  is the mean free path and  $d$  the particle diameter.

TABLE I: SLIP CORRECTION AS FUNCTION OF PARTICLE DIAMETER

$d$ [ $\mu\text{m}$ ]	Slip correction $C(d)$
100	1.0015
10	1.0154
1	1.1546
0.1	2.9282
0.01	22.9764

Table I shows that Cunningham's slip correction is of little significance for particles with diameters above 1  $\mu\text{m}$ . Between 0.1 and 1  $\mu\text{m}$  Cunningham's slip correction raises to almost a factor of three, and below 0.1  $\mu\text{m}$ , it raises dramatically.

#### 3.2.2.2. Non-Stokean flow

The second modification necessary is for non-Stokesian flow. It is of use to discuss this by introducing a drag coefficient:  $C_{Drag}$ , which modify the drag equation for spherical particles:

$$F_{Drag} = - C_{Drag} 3 \pi \mu_{Air} d_p v / C_{Slip}(d) \quad (5)$$

TABLE II: VALUES OF DRAG COEFFICIENTS AS FUNCTION OF REYNOLD'S NUMBER [5]

Re	Drag coefficient	Errors
< 1	24/Re	
1 – 1000	$\frac{24}{\text{Re}} \left( 1 + \frac{\text{Re}^{2/3}}{6} \right)$	Re from 3 to 400: 2% Re from 400 to 1000: 10%
1000 – 200000	0.44	

### 3.2.2.3. Non-spherical particles

Further, a modification is needed for non-spherical particles:

$$F_{Drag} = - 3 \pi \mu_{Air} \phi d_V v C_{Drag}/C_{Slip}(d) \quad (6)$$

where  $d_V$  is the equivalent volume particle diameter and  $\phi$  is the shape factor.

TABLE III: SHAPE FACTORS

Types	Shape factor ( $\phi$ )
Spheres <sup>A)</sup>	1.00
Cubes <sup>B)</sup>	1.08
Clusters of spheres <sup>B)</sup>	1.12 (2 chain) 1.27 (3 chain) 1.15 (3 chain compact) 1.32 (4 chain) 1.17 (4 chain compact)
Fibre (L/d=4) <sup>A)</sup>	1.32 (axis perpendicular to motion) 1.07 (axis parallel to motion)
Bituminous coal <sup>B)</sup>	1.05–1.11
Sand <sup>B)</sup>	1.57
Quartz dust <sup>A)</sup>	1.36
Fused aluminium <sup>A)</sup>	1.04–1.49
Platelet shaped talc <sup>A)</sup>	2.04

<sup>A)</sup> Ref. [3].

<sup>B)</sup> Ref. [8].

Shape factors are averaged over all orientations except where noted otherwise.

Besides the drag force, which describes the air resistance to the particles motion, other forces exist: Forces due to gravity, moving air, electrostatic forces, and concentration and thermal gradients. The set of equations needed to describe particle motions in general becomes quite complicated. In this paper, only single examples will be given, which are pertinent to occupational settings, but their relative influence on particles' movement will be calculated.

## 3.3. External forces

### 3.3.1. Force of gravity

Particles in a gravity field are influenced by the force of gravity, the drag force, and a force due to buoyance. The later is according to the law of Archimedes (Archimedes, ca. 287 — ca. 212 BC), which says that a body in a fluid is acted on by a force equal to the weight of the fluid it has displaced. Newton second law:

$$m dv_p/dt = m \times g = F_{Buoyance} + 3 \pi \mu_{Air} d_p v_p / C_{Slip}(d) \quad (7)$$

$F_{Buoyance}$  is the force due to buoyance, which may be neglected, as the density of air is  $1.29 \text{ kg}\cdot\text{m}^{-3}$  at STP, whereas density of, e.g. water is  $1000 \text{ kg}\cdot\text{m}^{-3}$ . Rearranging gives:

$$dv_p/dt + v_p/\tau - g = 0 \quad (8)$$

where  $\tau = C_{Slip}(d) d_p^2 \rho_p / 18 \mu_{Air}$  [s].  $\tau$  is called the particle relaxation time, which is the time it takes for the particle to come into dynamic equilibrium with the forced acting upon it, i.e. in the case of a falling particle, the time it take to reach its terminal or sedimentation speed.  $d_p$  is the particle diameter [m] and  $\rho_p$  is the particle density [ $\text{kg}\cdot\text{m}^{-3}$ ]

TABLE IV: RELAXATION TIME FOR PARTICLES AS FUNCTION OF PARTICLE DIAMETERS

d [ $\mu\text{m}$ ]	Water $\tau$ [s]	Minerals $\tau$ [s]	Uranium $\tau$ [s]
100	3.07E-02	9.22E-02	5.83E-01
10	3.12E-04	9.35E-04	5.91E-03
1	3.54E-06	1.06E-05	6.72E-05
0.1	8.99E-08	2.70E-07	1.70E-06
0.01	7.05E-09	2.12E-08	1.34E-07

It is of note that the relaxation times are very short. The equation may be solved, giving:

$$v_p = g \tau [1 - \exp(-t/\tau)] \quad (9)$$

For  $t \gg \tau$  ( $t > 3\tau$  is suggested by Hinds [5]), the terminal falling speed or sedimentation speed is:

$$v_s = g \tau \quad (10)$$

Substitution for  $\tau$  gives:

$$v_s = \frac{\rho_p g d_p^2}{\left[ \frac{18 \mu_{Air} \phi}{C_{Slip}(d_p)} \right]} \quad (11)$$

Sedimentation rates for spherical particles (for which  $\phi = 1.00$ ) are calculated in Table V:

TABLE V: SEDIMENTATION RATES FOR SPHERICAL PARTICLES

d [ $\mu\text{m}$ ]	Water $v_s$ [ $\text{m s}^{-1}$ ]	Minerals $v_s$ [ $\text{m s}^{-1}$ ]	Uranium $v_s$ [ $\text{m s}^{-1}$ ]
100	3.02E-01	9.05E-01	5.71E+00
10	3.06E-03	9.17E-03	5.79E-02
1	3.48E-05	1.04E-04	6.59E-04
0.1	8.82E-07	2.65E-06	1.67E-05
0.01	6.92E-08	2.08E-07	1.31E-06

The density of uranium is about 19 times the density of water. This difference in density causes a particle of uranium to have a sedimentation velocity 19 times higher than a water droplet of the same form and diameter. The sedimentation velocity is proportional to density:  $v_s = k_1 \rho$ . Particle diameter has a more profound influence:  $v_s = k_2 d^2$ . The sedimentation velocity of a particle having a diameter of 100  $\mu\text{m}$  is more than 4000000 times that of a particle of the same material and shape with a 0.01  $\mu\text{m}$  diameter.

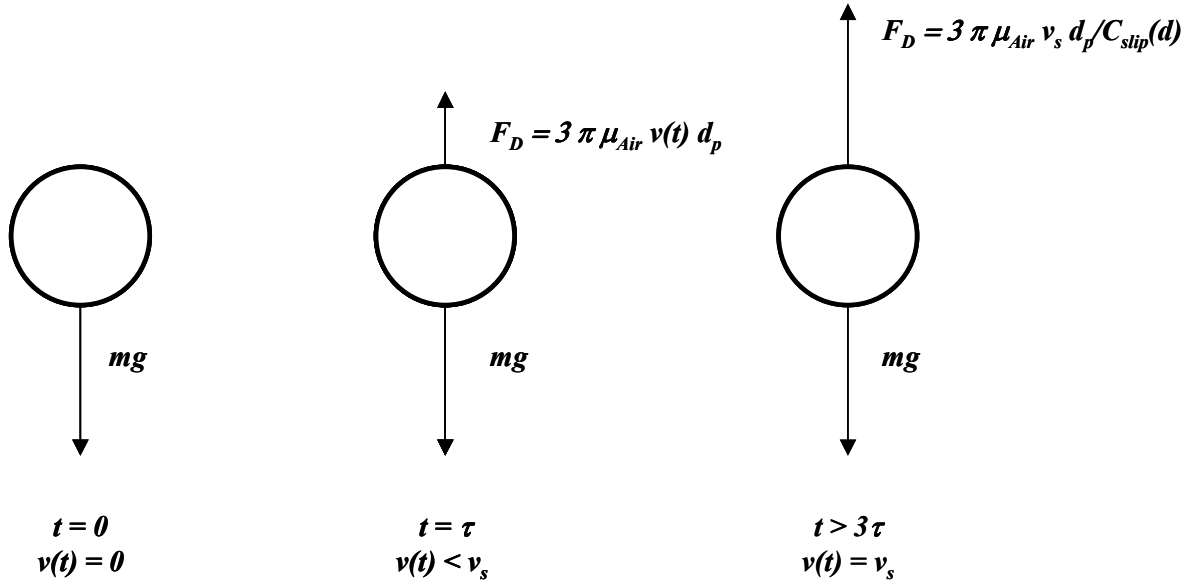

FIG. 2. Sedimentation of particles.  $m$ : mass of particle,  $g$ : the constant of gravity,  $v(t)$ : velocity at time  $t$ ,  $F_D$ : drag force.  $d$ : diameter of particle.  $\mu_{Air}$ : viscosity of air.  $C_{slip}(d)$ : Cunningham's slip factor.  $\tau$ : relaxation time.

### 3.3.2. Particles in moving air (or moving particle in stagnant air)

Movement of particles influenced by no external forces in the direction of their movement can be described in two scenarios: 1. The initial velocity of the particle is zero and the air is moving. 2. The initial velocity is finite, but the air is stagnant. The two scenarios are equivalent; it depends on the definition of the coordinate system.

The stop distance is the distance a particle, which has a finite velocity, travels before it comes to rest relative to the air, i.e. becomes in dynamic equilibrium with the air. If a particle with zero velocity in the air's flow direction is injected into airflow it will at first lag behind the air. The drag force extended by the flowing air will gradually increase the velocity of the particle until it reaches the same speed as the air. The particle has become airborne.

$$m (dv_x / dt) = -3 \pi \mu d_p v_x / C_{slip}(d) \quad (12)$$

which solved gives:

$$v_x = v_{x0} \exp(-t / \tau) \quad (13)$$

where  $v_{x0}$  is the speed relative to the air at  $t = 0$ ; and with further manipulation:



$$s = v_{xo} \tau \quad (14)$$

where  $s$  is the stop distance: the distance travelled by the particle before it comes to rest — or, changing viewpoint, the distance travelled before it achieves the same velocity as the moving air.

TABLE VI: STOP DISTANCE (INERTIAL RANGE) AS FUNCTION OF PARTICLE DIAMETER WITH INITIAL VELOCITY OF  $3.27 \text{ m}\cdot\text{s}^{-1}$

d [ $\mu\text{m}$ ]	Water [m]	Minerals [m]	Uranium [m]
100	1.01E-01	3.02E-01	1.90E+00
10	1.02E-03	3.06E-03	1.93E-02
1	1.16E-05	3.48E-05	2.20E-04
0.1	2.94E-07	8.82E-07	5.57E-06
0.01	2.31E-08	6.92E-08	4.37E-07

Initial velocity of  $3.27 \text{ m}\cdot\text{s}^{-1}$  is the linear velocity of air in the human throat (see Table XIII) Considering spherical particles of uranium injected into stagnant air having an initial velocity of  $110 \text{ km}\cdot\text{h}^{-1}$ : A  $100 \mu\text{m}$  particle will stop after approximately 18 m, whereas a  $0.01 \mu\text{m}$  particle will stop after  $4.0 \times 10^{-6} \text{ m}$  or  $4.0 \mu\text{m}$ .

### 3.3.3. Particles in electric fields

Only recently, electrical properties have been given attention in aerosol science. A growing number of investigations have shown that the electrical properties of aerosols have a substantial practical relevance, e.g. on deposition in the lungs, when sampling airborne aerosols, and when the air is cleaned by filtration.

Johnston et al. [9] found, irrespective of the type of aerosol and how they were generated that each particle was charged either net positive or net negative and that the distribution of charges were almost symmetrically between positive and negative. The aerosols as a whole, therefore, were close to neutral. They also found that the median charge per particle ( $q_m$ ) could be expressed as

$$|q_m/e| = Ad^n \quad (15)$$

The electron charge,  $e = 1.6 \times 10^{-19} \text{ C}$  (Coulombs).  $A$  and  $n$  are constants, the sizes of which depend on the material considered and the process during which the particles are created (see Table VII) below.

The charge per particle of fibres, e.g. asbestos is relative independent of the fibre diameter, but approximately proportional to its length:

$$|q_m e| = \sigma L \quad (16)$$

where  $\sigma$  is the charge per unit length of the fibre.  $\sigma$  is a constant of proportion, which depends on the material considered and the process during which the particles are created (see Table VII) below.  $L$  is the length of the fibre.

TABLE VII: SOME VALUES OF A, n AND  $\sigma$

<i>Industry</i>		<i>A</i>	<i>n</i>	$\sigma$
		<i>Dimensionless</i>	<i>Dimensionless</i>	<i>Charge/<math>\mu\text{m}</math> length</i>
Jute	Batching	22.3	1.03	
	Spreading	27.8	0.80	
	Carding	28.6	1.19	
	Spinning	13.2	1.44	
	Winding	13.0	1.16	
Silica A		11.2	1.01	
Silica B		10.1	1.21	
Silica C		24.1	0.72	
Coalmine	Return roadway	25.0	1.20	
Asbestos 1.	Carding			13.0
	Spinning			10.1
	Weaving			9.6
Asbestos 2.	Carding			8.4
	Spinning (dry)			11.0
	Spinning (wet)			4.9
	Weaving			6.0

Electrostatic force is of relevance for deposition in the alveoli and when sampling particles carrying electrical charges:

$$F_C = q^2 x R / 4 \pi \epsilon_0 (R^2 - x^2)^2 \quad (17)$$

$\epsilon_0$  is the permittivity of vacuum =  $8.85 \times 10^{-12}$  A s V<sup>-1</sup> m<sup>-1</sup>.  $R$  is the alveoli radius and  $x$  is the distance of the particle from the centre of the alveoli sac. It is of note that the electrostatic force rises sharply, when the particle approaches the alveoli wall, because  $(R^2 - x^2)^2$  approaches zero.

### 3.3.4. Thermal gradients

Airborne particles will, if they experience a thermal gradient, receive more momentum from the colliding air molecule from the hot than from the cold region, because the warmer molecules have higher velocities. Therefore, a net force is acting in the direction from the hot to the cool region.

For particles with diameters close to mean free path in air (=  $6.6 \times 10^{-8}$  m at STP) the thermophoric velocity is:

$$v_T = -k_l \Delta T \quad (18)$$

where  $k_l$  is a constant, which does depend on the local temperature ( $T$ ) but not on particles size or composition, when the particle is small.  $\Delta T$  is the temperature gradient and the minus sign indicates the direction of the thermophoretic motions towards the cold region. The thermophoretic drift has been estimated to be of the order of  $2 \times 10^{-6}$  m·s<sup>-1</sup> per K [3]. Compare with Table V. For a thermal gradient of 1 K·cm<sup>-1</sup> the thermophoretic velocity of a 0.01- $\mu\text{m}$  particle is 42 times the terminal sedimentation velocity. For a 0.1- $\mu\text{m}$  particle it is 2.3 times and for a 1- $\mu\text{m}$  it is 0.04 times. Compared with deposition due to Brownian diffusion, deposition due to thermal gradient of a 1 K·cm<sup>-1</sup> is 0.1 times the deposition due to diffusion.

For a 0.1- $\mu\text{m}$  particle it is 0.7 times and for a 1- $\mu\text{m}$  particle it is 2.2 times. For larger particles the size and composition of the particle cannot be ignored, e.g. the temperature gradient within the particle must be taken into consideration. Not mentioned in this going through external forces, which influence particles are magnetic and photophoretic forces.

### 3.3.5. Brownian diffusion

The smooth motion of small airborne particles have a random movement superimposed the motion due to external forces described above. The random motion is due to collisions with other particles and with air molecules, which themselves are in thermal motion. The phenomenon is called Brownian motion after R. Brown (1827). When a concentration gradient exists, the particles will experience more collisions if their random walk is up the concentration gradient than when it is down the concentration gradient, resulting in a net flux of particles down the gradient, the more the steeper the gradient. Fick's first law describes this phenomenon:

$$dN/dt = -D A (dC/dx) \quad (19)$$

where  $N$  is number of molecules (or mass), which travels in the  $x$  direction per second through the area  $A$  caused by the number or mass concentration gradient  $dC$ . The coefficient  $D$  [ $\text{m}^2 \cdot \text{s}^{-1}$ ] is called the diffusion coefficient. It can be calculated from kinetic theory:

$$D = \frac{kT}{\left[ \frac{3\pi\mu_{Air}d_p}{C_{Slip}(d_p)} \right]} \quad (20)$$

$k$  is the Boltzmann's constant ( $= 1.38 \times 10^{-23} \text{ J} \cdot \text{K}^{-1}$ ),  $T$  is the absolute temperature [K],  $\mu_{Air}$  is the viscosity of air ( $= 1.81 \times 10^{-5} \text{ Pa} \cdot \text{s}$ ), and  $d_p$  is the particle diameter [m].  $C_{Slip}(d_p)$  is the Cunningham slip correction factor for the particle. It is of note that the numerator represents the thermal energy of the gas molecules transferred to the particles and the denominator in the squared parenthesis represents the loss of particle kinetic energy due to viscous effects. The diffusion coefficient, therefore, embodies the continual interchange of thermal energy between the gas molecules and particles and vice versa [3].

TABLE VIII: DIFFUSION COEFFICIENT AS FUNCTION OF PARTICLE DIAMETER

d [ $\mu\text{m}$ ]	Diffusion coefficient D [ $\text{m}^2 \text{ s}^{-1}$ ]
100	2.3751E-13
10	2.4081E-12
1	2.7382E-11
0.1	6.9442E-10
0.01	5.4488E-08

For comparison, the diffusion coefficient of air molecules is  $1.99 \times 10^{-5} \text{ m}^2 \cdot \text{s}^{-1}$ . Thus the air molecules in average will diffuse 365 times faster than a particle with a diameter of 0.01  $\mu\text{m}$ , 727000 times faster than a particle with a diameter of 1  $\mu\text{m}$ , and 83786000 times faster than a particle with a diameter of 100  $\mu\text{m}$ .

### 3.3.6. Turbulent Flow

In laminar flow of air, the air layers slide smoothly over one another. But if the forces involved are much larger than the viscous forces, i.e. Reynolds number (Re) is large enough, then the flow will be instable resulting in a random-fluctuating motion superimposed on the mean flow [3], which cause a apparent increase in viscosity.

Turbulence is an extremely complex phenomenon, which cannot be treated in details in a single paper. However, the occupational hygienist should notice that the diffusivity of turbulent air movement is of the order of the order  $10^{-3} \text{ m}^2 \cdot \text{s}^{-1}$  [3], whereas diffusion of carbon dioxide due to Brownian motions has a diffusion coefficient of  $1.39 \times 10^{-5} \text{ m}^2 \cdot \text{s}^{-1}$ , which is 100 times lower. Transport of airborne particles in the working environment, therefore, is not primarily due to Brownian diffusion, but due to turbulent air eddies, caused by draft and air warmed up by machines and humans.

### 3.4. Agglomeration

Small particles agglomerate when colliding with one another, resulting in a decrease in the number concentration and the surface concentration. The mass and volume of the single particle increases, whereas the total mass and volume of the aerosol obviously stay constant.

The deviation of equations in the general case is rather complicated. For the simple case of monodisperse spherical particles the change in number concentration:

$$\frac{dn}{dt} = - 4 \pi d_p D_p n^2 = - K n^2 \quad (21)$$

where  $K$  is called the agglomeration coefficients, which is equal to  $4 \pi d_p D_p [\text{m}^3 \cdot \text{s}^{-1}]$  an expression, which needs correction [5].

TABLE IX: AGGLOMERATION COEFFICIENTS K AT STP

d [ $\mu\text{m}$ ]	Correction Factor $\beta^{1)}$ Dimensionless	Agglomeration coefficient $K^*$ [ $\text{m}^3 \cdot \text{s}^{-1}$ ]	Corrected agglomeration coefficient K [ $\text{m}^3 \cdot \text{s}^{-1}$ ]
100	1	2.98E-16	2.98E-16
10	0.99	3.03E-16	3.00E-16
1	0.97	3.44E-16	3.34E-16
0.1	0.82	8.73E-16	7.16E-16
0.01	0.14	6.85E-15	9.59E-16

\* [5]; <sup>1</sup>according to [5]

$$n(t) = \frac{n_0}{1 + n_0 K t} \quad (22)$$

where  $n_0$  is the number concentration at  $t = 0$ .

$$d(t) = d_0 (1 + n_0 K t)^{1/3} \quad (23)$$

thus, when the diameter of the particles is doubled then the number concentration is decrease with a factor of eight. This simple equation is valid only for monodisperse spherical particle, which agglomerate into monodisperse spherical particle without pores. Porous agglomerates will grow faster than predicted by the equation.

TABLE X: TIME FOR NUMBER CONCENTRATION TO HALVE AND PARTICLE SIZE TO DOUBLE FOR 1  $\mu\text{m}$  MINERAL PARTICLES

$N_0$ [ptc $\text{m}^{-3}$ ]	Mass concentration [ $\text{mg}\cdot\text{m}^{-3}$ ]	Time to reach 0.5 $n_0$		Time to double particle size	
$10^{20}$	1.57E+11	30	$\mu\text{s}$	208	$\mu\text{s}$
$10^{18}$	1.57E+09	3	ms	21	ms
$10^{16}$	1.57E+07	297	ms	2	s
$10^{14}$	1.57E+05	30	s	3	min
$10^{12}$	1.57E+03	49	min	6	h
$10^{10}$	1.57E+01	82	h	24	days
$10^8$	1.57E-01	343	days	7	years

Monodisperse spherical mineral particles, with a diameter of 1  $\mu\text{m}$ , agglomerate into monodisperse, non-porous agglomerates.  $K = 3.37\text{E-}16 \text{ m}^3\cdot\text{s}^{-1}$  see Table IX. ptc: particles.

Table X defines concentration regions where agglomeration can be neglected. Agglomeration will not be substantial if the concentration is less than  $10^{12}$  ptc  $\text{m}^{-3}$ , when sampling for 15 minutes. For occupational hygiene, [5] suggested to neglect agglomeration when the number concentration is below  $10^{12}$  pct  $\text{m}^{-3}$ .

For calculation on polydisperse spherical particle aerosols having a lognormal size distribution see [5].

### 3.5. Adhesion of particles to surfaces

Adhesive forces can be measured as the force required separating a particle from a surface. For hard materials and clean surfaces an expression for the adhesive force is given, based on direct measurements:

$$F_{Adhesive} \approx 0.063 d_p [1 + 0.009 (\%RH)] \quad (24)$$

Where %RH is the relative humidity expressed in per cent [5].

TABLE XI: COMPARISON OF FORCES ACTING ON PARTICLES

$d_p$ [ $\mu\text{m}$ ]	Forces [N]				
	Adhesion <sup>1)</sup>	Gravity	Air current <sup>2)</sup>	Adhesion relative to gravity	Adhesion relative to air current
100	1.1E-05	1.5E-08	6.00E-07	7.1E+02	1.8E+01
10	1.1E-06	1.5E-11	3.00E-08	7.1E+04	3.6E+01
1	1.1E-07	1.5E-14	2.00E-09	7.1E+06	5.4E+01
0.1	1.1E-08	1.5E-17	1.50E-10	7.1E+08	7.3E+01
0.01	1.1E-09	1.5E-20	1.00E-11	7.1E+10	1.1E+02

<sup>1)</sup> predicted by:  $F_{Adhesive} \approx 0.063 d_p [1 + 0.009 (\%RH)]$ ; where %RH=50. <sup>2)</sup>  $v_{Air} = 10 \text{ m}\cdot\text{s}^{-1}$  [5].

Adhesive forces are proportional to  $d_p$ , but removal forces (e.g. vibration) are proportional to  $d_p^3$  whereas removal forces for air current are proportional to  $d_p^2$ . That is, small particles are more difficult to remove than larger particles. Table XI shows the adhesive force for particles with diameters less than 100  $\mu\text{m}$  [5]. The adhesive forces are larger than forces due to gravity and air currents. The more, the smaller the particles.

### 3.6. Deposition of particles on surfaces

Solid particles adhere when they collide with surfaces. The aerosol concentration at the surface, therefore, is zero and consequently a concentration gradient exists, which maintain a flux of particles from the bulk air to the surface. The particle number concentration  $n(x,t)$  in distance  $x$  at time  $t$  must satisfy Fick's second law:

$$\frac{dn}{dt} = D \frac{d^2n}{dx^2} \quad (25)$$

and Fick's first law

$$\frac{d\left(\frac{N}{A}\right)}{dt} = -D \frac{dn}{dx} \quad (26)$$

Combining these equations gives the cumulative deposition per unit area due to Brownian diffusion:

$$\frac{N(t)}{A} = 2n_0 \sqrt{\left(\frac{Dt}{\pi}\right)} \quad (27)$$

The equation applies only to a large aerosol volume, where  $n_0$  is constant, i.e. it gives the upper limit of the deposition rate per square meter.

TABLE XII: CUMULATIVE DEPOSITION OF UNIT-DENSITY PARTICLES FROM AN AEROSOL ONTO A HORIZONTAL SURFACE

Cumulative deposition			
$d_p$ [ $\mu\text{m}$ ]	Diffusion [ptc $\text{m}^{-2}\text{s}^{-1}$ ]	Settling [ptc $\text{m}^{-2}\text{s}^{-1}$ ]	Ratio diffusion/settling
100	5.50E-02	250000	2.20E-07
10	1.75E-01	3100	5.65E-05
1	5.93E-01	35	1.69E-02
0.1	2.95E+00	0.85	3.47E+00
0.01	2.60E+01	6.9E-02	3.77E+02

Number concentration at  $t = 0$ :  $n_0 = 10^6$  ptc  $\text{m}^{-3}$  (Ref. [5]). ptc: particles.

For large particles, settling is the dominating mechanism of deposition of particles. For smaller particles the dominating mechanism is diffusion.

#### 4. THE HUMAN RESPIRATORY TRACT

The primary objective of the human respiratory tract is to supply the body with oxygen and to excrete carbon dioxide and other gases. The air is inhaled through either the nose or the mouth. In the nose, the air is warmed and humidified before it is entering the lungs. The surface of the nose is ciliated, so foreign particles are transported in the mucous layer. In the anterior parts of the nose particles are ciliated forwards (half-life about 24 hours) in the back of the nose particles are ciliated backward towards the throat (half-life about 10 minutes) where they can be swallowed [10].

A simple model of the human airways is shown in Figure 3.

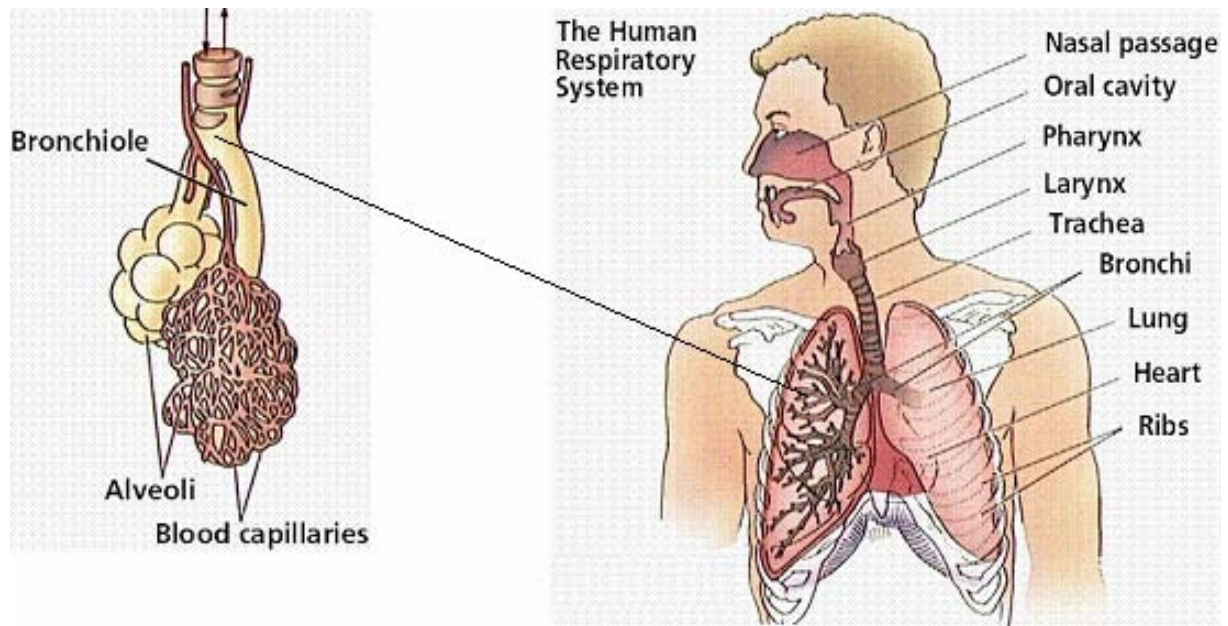

FIG. 3. The human airways.

In Weibel's model [11] the lungs consist of bronchioles, which for each generation branches into two. In total 24 generations. The airway diameter is reduced following an exponential function:

$$d_z = d_0 2^{-z/3} \quad (28)$$

where  $d_z$  and  $d_0$  are the diameters in generation  $z$  and 0 respectively. This relation is known to reflect an optimal design for mass flow of air with minimal energy loss [12]. Table XIII shows the size of the airways and the flow conditions:

TABLE XIII: WEIBEL'S MODEL OF THE HUMAN AIRWAYS

Region	Generation	Number in generation	Diameter [cm]	Length [cm]	Volume [cm <sup>3</sup> ]	Mean air velocity [cm s <sup>-1</sup> ]
Throat	0	1	1.8	12	30.5	327
Extrathoracic bronchial region	1	2	1.22	4.76	11.0	356
Tracheobronchial region	5	32	0.35	1.07	3.0	271
Respiratory bronchial region	10	1024	0.13	0.46	6.2	61.5
Alveolar duct	16	65500	0.06	0.17	30.5	4.75
Alveolar sacs	23	8390000	0.04	0.05	554.0	0.075
	24	300000000	0.03	0.02	3200.0	0.001

Ref.[11]. In the first 16 generation the airflow is turbulent. After the 17–18 generation the airflow is laminar [10]. The air velocity is given for a tidal volume of 1450 cm<sup>3</sup> [10]. In Table XIII, the ciliated compartments are shaded.

Above the respiratory bronchial region the surfaces are covered with cilia and mucous layer, which transport foreign particles upwards towards the larynx for eventually being eliminated through the gastrointestinal tract. The half-life is about 2 hours [10].

The tidal volume is about 0.5 dm<sup>3</sup> at rest and the reserve air volume is 2–3 dm<sup>3</sup>. The maximal volume of air inhaled is about 2 dm<sup>3</sup>. In the alveoli the mixing does not take place by convection but by diffusion. As there are no cilia in the alveolar region, the alveoli are not cleared by this mechanism. Instead clearance is performed by macrophages present on the surface of the alveoli.

Typically the volumetric flow rate is 7 dm<sup>3</sup>·min<sup>-1</sup>, which increased to above 20 dm<sup>3</sup>·min<sup>-1</sup> during moderate to hard work. The frequency of inspiration is about 12 times per minute [10]. As a rough conservative estimate, a worker inhales and exhales 10 m<sup>3</sup> per 8 hour working time.

## 5. DEPOSITION OF PARTICLES IN THE HUMAN AIRWAYS

### 5.1. Aerodynamic Diameter

Particles suspended in air move under gravimetric, electrostatic, and thermophoric forces. The movement depend on the particle's size, form, density, etc. All these variables can be summarized in the concept of the aerodynamic diameter.

A particle's aerodynamic diameter is the diameter of a spherical droplet with a density of 10<sup>3</sup> kg·m<sup>-3</sup> (density of water at 4°C), with the same terminal velocity in calm air as the particle considered [1].

$$d_{Ae} = d_V (\rho C_{Slip}(d) C_D^* Re_p^* / \rho^* C_{Slip}(d)^* C_D Re_p \phi)^{1/2} \quad (29)$$

where  $d_{Ae}$  is the aerodynamic diameter,  $d_V$  is the volumetric based diameter,  $\rho$  is the particle diameter,  $C_{Slip}(d)^*$  is the Cunningham slip factor.  $C_D^*$  is the drag factor,  $Re_p^*$  is the Reynolds



number, and  $\rho^*$  is the density for the particle respectively for the particle.  $C_{Slip}(d)$ ,  $C_D$ , and  $Re_p$  are the corresponding values for the equivalent aerodynamic particle;  $\phi$  is the form factor.

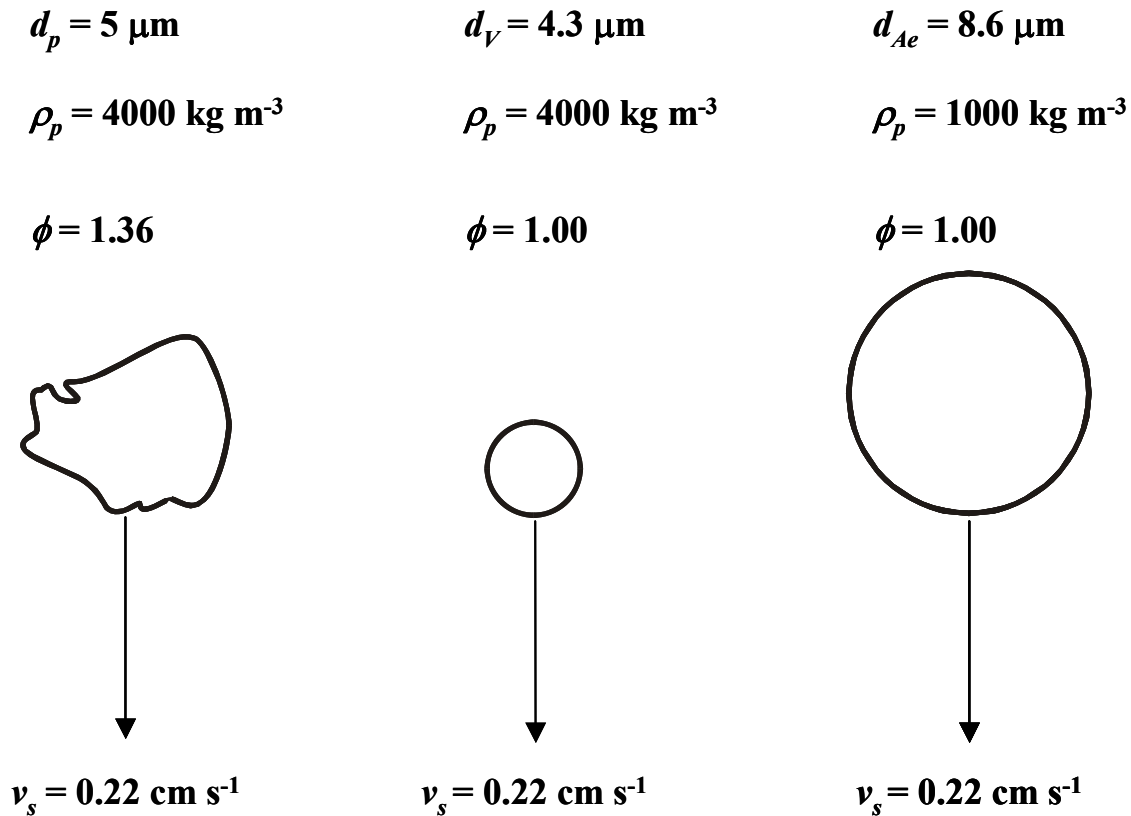

FIG. 4. From irregular shape to aerodynamic particle (Ref. [5]).  $d_p$ : particle diameter.  $d_V$ : particle diameter of a equivalent spherical particle.  $d_{Ae}$ : aerodynamic diameter.  $\rho$ : particle density.  $v_s$ : sediment velocity.  $m$ : particle mass,  $g$ : constant of gravity.

For thin fibres, e.g. asbestos, [13] derived the following aerodynamic diameter when the fibre falls with its axis perpendicular to the direction of motion:

$$(d_{Ae}/d)^2 (\rho^*/\rho) = (9/8) (\ln(2L/d) + 0.193) \quad (30)$$

and for falls with the axis parallel to the direction of movement:

$$(d_{Ae}/d)^2 (\rho^*/\rho) = (9/4) (\ln(2L/d) + 0.807) \quad (31)$$

where  $L$  is the length and  $d$  the diameter of the particle, respectively. Experiments on amosite asbestos suggest that these fibres fall with their axis close to horizontal [14].

## 5.2. Aerosol fractions

Depending of the particles' aerodynamic diameters, an aerosol can be divided into fractions after their behaviour in the human airways: 1. **Inhalable** (or inspirable) **Fraction**: the fraction of total airborne particles, which is inhaled through the nose. It depends on speed and direction of the air movement, breathing rate, and other factors. 2. **Thoracic Fraction**: the fraction of inhaled particles, which can penetrate beyond the larynx. 3. **Alveolar Fraction**: the fraction of inhaled particles, which can penetrate to the unciliated airways. [1] calls this

fraction the respirable fraction meaning particles, which can penetrate to the alveolar, but also can be exhaled again.

## 6. CONVENTIONS FOR SAMPLING INSTRUMENTS

It is of special importance for assessing risk of adverse health effect in humans exposed to aerosols to measure the fractions, which are deposited in the upper airways, the thoracic region, and in the alveoli. Because all measuring instruments are size selective to some extent, it is often impossible to measure the total airborne particle concentration. The Inhalable Convention is the target specification for sampling instruments, when measuring the Inhalable Fraction. The Thoracic Convention is the target specification for sampling instruments, when measuring the Thoracic Fraction, and the Alveolar (Respirable) Convention is the target specification for sampling instruments, when measuring the Alveolar Fraction.

Inhalable Convention is given by

$$E_{Inhalable} = 50 (1 + \exp\{-0.06 d_{Ae}\}) \quad (32)$$

$d_{Ae}$  is in  $\mu\text{m}$ . (EN 431, 1993)

Thoracic Convention ( $E_{Thoracic}$ ) is given by the cumulative lognormal distribution with a median of 11.64 [ $\mu\text{m}$ ] and a geometric standard deviation of 1.5 [1].

Alveolar (Respirable) Convention ( $E_{Alveolar}$ ) is given by the cumulative lognormal distribution with a median of 4.25 [ $\mu\text{m}$ ] and a geometric standard deviation of 1.5 [1].

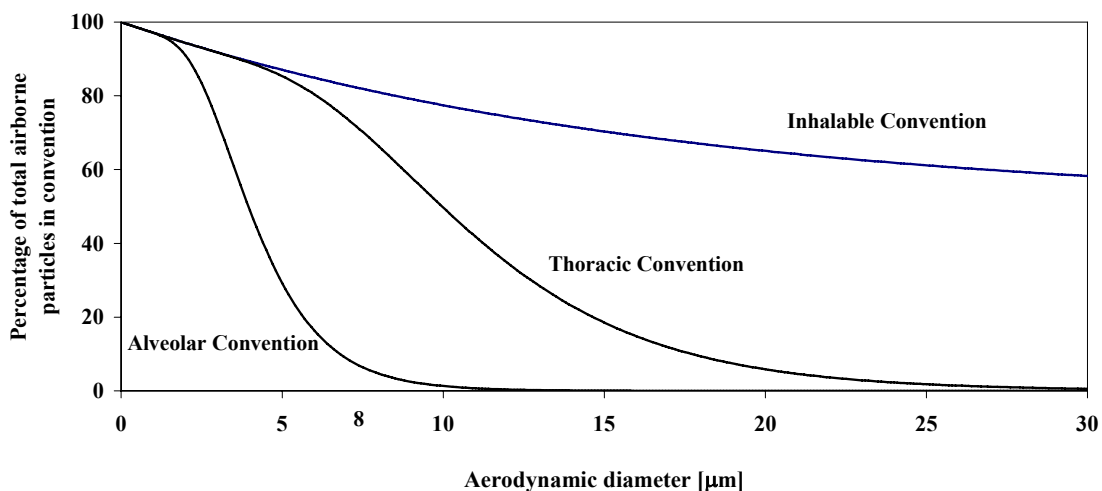

FIG. 5. International Conventions on aerosols [1].

## 6.1. Particles deposited in the human airways

Particles deposit in the human airways by a complex action of the five deposition mechanisms:

- Interception
- Inertial impaction
- Diffusion
- Gravitational settling
- Electrostatic attraction

The extrathoracic deposition refers to particles, which are deposited in the upper airways. The deposition during mouth breathing is quite different from deposition when the person is breathing through the nose, but in both cases mainly due to impaction and to a lesser degree due to gravity. Electrostatic deposition has been shown to be minute [15]. The particles deposited in the upper airways compartment become equal to:

$$E_{Inhalable} - E_{Thoracic}$$

Because of the high air velocity in the thoracic compartment, particles are deposited due to impaction. [16] found that electrostatic deposition is small. The deposition becomes equal to:

$$E_{Thoracic} - E_{Alveolar}$$

The low air velocities in the alveoli make deposition by impaction almost not existing. Gravitational settling, electrostatic forces and diffusion deposit the particles, which enter the alveolar region. Table V shows that the terminal sedimentation rate is very low for small particles, but the distance they must travel in order to reach the lung surface is only a fraction of the diameter of the alveolar sacs, which is of the order of 300  $\mu\text{m}$ . The largest of the particles deposit, therefore, mainly due to gravimetric settling, because, of the particles capable to penetrate to the alveolar region, they have the smallest diffusion coefficients. The smallest particles have the highest diffusion coefficients, but the smallest sedimentation rates. It therefore follows that efficiency of deposition as function of geometric diameter goes through a minimum considering particles of the same density.

Table XIV shows deposition of particles in the different compartments of the airways as function of aerodynamic diameter. Particles above 10  $\mu\text{m}$  do not penetrate into the alveoli, because they are deposited in the upper airways.

In the alveolar region a substantial contribution to deposition comes from electrostatic deposition. Especially thin ( $d \approx 1 \mu\text{m}$ ), long fibre may have a very small aerodynamic diameter. Such fibres can therefore penetrate into the alveoli. Despite their small aerodynamic diameter, they are geometrically large and can therefore carry a large electrical charge, which make electrostatic deposition likely.

TABLE XIV: PERCENT DEPOSITED IN THE DIFFERENT COMPARTMENTS OF THE HUMAN AIRWAYS

$d_{Ac}$ $\mu m$	Not inhaled	Inhaled Convention	Thoracic Convention	Alveoli Convention	Deposited in ext thoracic compartment	Deposited in thoracic compartment	Exhaled	Deposited in the alveoli
100	49.88	50.12	0.00	0.00	50.12	0.00	0.00	0.00
10	22.56	77.44	49.67	1.31	27.77	48.36	0.00	1.31
2.5	6.96	93.04	93.03	83.38	0.01	9.65	65.12	18.25
1	2.91	97.09	97.09	97.06	0.00	0.03	75.73	21.33
0.1	0.30	99.70	99.70	99.70	0.00	0.00	69.79	29.91
0.01	0.03	99.97	99.97	99.97	0.00	0.00	67.98	31.99

Ref. [3].

Some of the particles penetrating into the alveoli region remain airborne and are therefore exhaled. The efficiency of exhalation,  $E_{exh}$ , is given by:

$$E_{Exh} = 1 - E_{Totdep}$$

The amount of particles exhaled has been calculated as the amount of the fraction of particles inhaled, which has not been deposited in the ext thoracic, the thoracic, and the alveoli compartment [3].

The particles deposited in the alveolar compartment becomes equal to:

$$E_{Alveolar} - E_{Exhaled}$$

Particles must deposit to have a biological effect. The measuring conventions, therefore, underestimate the biological effect of a given amount of deposited particles, which penetrate to the alveolar compartment, because what is measured is the amount reaching the compartment ( $E_{Alveolar}$ ), not the amount deposited ( $E_{Alveolar} - E_{Exhaled}$ ). If the mass of particles inhaled is of concern, the mass of the exhaled particle may be disregarded for two reasons: the measured result is conservative and the mass of the minor particles which reach the alveoli is only small, compared with the mass of the total aerosol inhaled.

## 7. DISTRIBUTIONS OF AIRBORNE PARTICLES

The objective is to investigate which measures of exposure are relevant for different types of aerosols:

Particle Number Distribution is of concern when risk is related to number of particles inhaled. This is for instance the case when aggregates of infectious microorganisms are measured. [17] found that respiratory effects were associated with the number of ultrafine particles. When analysis is done by microscope, number distribution is an obvious choice for characterising the exposure.

Volume Distributions or particle diameter distributions is often measured, when samples are analysed by mean of microscopes.

Surface Distribution is of concern, when the toxic or corroding substance is adsorbed on the surface of dust particles. Exposure to surface area per day is the dose, which predicts pulmonary disease [18].

Mass Distribution is of concern, when all particles have the same percentage (by weight) of the element or compounds considered and risk is related to the number of moles of toxic elements or compounds.

Distribution of Trace Element is of concern when the percentage of the toxic elements or compounds considered depends on the size of the particles.

## 8. VISIBILITY

The wavelength of light range from approximately 0.39  $\mu\text{m}$  (blue) to 0.78  $\mu\text{m}$  (red) that is of the same order of magnitudes as some types of aerosols, see Figure 1. The light absorbs into the particles or is reflected (scattered) from the particles' surfaces. The absorption and scattering together is called the extinction. What happens depends on the diameter of the particles, the concentration, the wavelength of the light, etc. The sky looks blue because the blue wavelengths of the white sunlight are reflected more than the red wavelengths in the air molecules and the aerosols of the atmosphere. The red colour of the sunset is caused by the same phenomenon. At sundown, the light travels a longer distance through the atmosphere and almost all blue wavelengths are absorbed or scattered, while the red wavelength are passing through. The extinction is largest for particles, the diameters of which are close to the wavelength of the light. For the same mass concentration, tobacco smoke looks ten times denser than an aerosol of wood dust with a mean particle diameter of about 6  $\mu\text{m}$  [10].

Without aid, it is possible for humans to see particles down to approximately 50  $\mu\text{m}$ . Smaller particles can only be seen if they are reflecting light and particles with diameters below 10  $\mu\text{m}$ , can only be perceived as "fog". In the literature it has been demonstrated that it is not possible to graduate, not to speak of to quantify, air concentration by observation alone [19]. If it is important to know the air concentration of particles in a given workplace, the concentration must be measured with one or more suitable method, some of which are described below.

## 9. METHODS FOR MEASURING EXPOSURE TO AIRBORNE PARTICLES

The first objective is to investigate, which sampling devices are available for collecting different fractions of solid aerosols.

The second objective is to give the reader background knowledge from which to choose between alternative methods for sampling solid aerosols, based on knowledge of the aerosols' distributions, using the theoretical information given above.

## 9.1. Air movers

A series of consideration must be taken, before selecting and/or buying air movers. The quantification limit of the analytical procedure and the sampling time determine, together with the expected air concentrations relative to the concentration levels of concern, the minimum demand to the capacity of the air moving equipment.

The maximum demand depends on the capacity of the collection medium. If filters are overloaded they clog and resistance is building up slowing down the sampling rate. Sampling rate determines what size of particulate matters will be removed most efficiently and therefore, distorting the measurement as far as concern the determination of the exposure and therefore the health risk.

Sometimes recommended sampling rates and total sampling times can be found in the literature. For instance Coal Mine Safety and Health Administration (1992) prescribes a flow rate of  $2 \text{ dm}^3 \cdot \text{min}^{-1}$ . US Environmental Protection Agency (1992) prescribes  $1.13 \text{ m}^3 \text{ min}^{-1}$  for  $\text{PM}_{10}$  sampling of ambient particulate matter. However, such data are much easier and cheaper provided via the Internet. A search on *www.google.com* using the key words: sample time sample rate and minerals gave 9080 hits in 2.79 seconds.

Before selecting and buying equipment also more practical problems must be considered e.g. difficulties involved in calibration and maintenance, the power supply available, i.e. availability of line current, generators, batteries, hand powered generators. Further, when sampling in flammable and/or explosive atmospheres equipment must be secure to use in such places. Measuring corrosive atmospheres or in very cold or very hot places, may require equipment consisting of special materials.

## 9.2. Collection devices

Devices for collecting particulate matter must do that isokinetic, i.e. sampling must be done in such a way that the size distribution of the particulate matter sampled is the same as in the sampled air. Sampling for instance is anisokinetic when it is performed in a flowing stream without aligning the collecting probe with the streamlines. When sampling from still air, a bias result when sampling at low rate and the inlet tube is facing upwards (positive bias) or downwards (negative bias).

For continuous sampling of particulate matter, several physical factors including gravity, interception, impaction, electrophoresis, thermophoresis, and diffusion are employed. Collector of aerosols can be divided into the following categories, which are treated below:

- *Settling chambers*
- *Centrifugal devices (e.g. cyclones)*
- *Impingers and impactors*
- *Bubblers*
- *Filters*
- *Electrostatic precipitators*
- *Thermophoretic precipitators*
- *Diffusion batteries*
- *Passive personal dust sampler*
- *Direct reading instruments*

### *9.2.1. Non-size selective sampling*

#### 9.2.1.1. Settling chambers

Elutriators, i.e. chambers in which the air is calm undistorted settling can take place due to gravitation. Sampling rates depend strongly on particle diameter and particle density (see Table V and VII).

### *9.2.2. Size selective sampling*

#### 9.2.2.1. Centrifugal devices

The range for human variation for lung retention is probably as great as for most physiological characteristics and changes in breathing rate and volume per breath. It profoundly affects the size retention characteristics of the respiratory system [4]. Nevertheless, sampling devices have been invented, which tries to simulate a standardised human lung particle size rejection curve. For the outdoor environment, size selective samplers have been developed with cut points of 2.5 and 10  $\mu\text{m}$  in aerodynamic diameter. The rationale is that the smaller particles originate from gas phase reaction in the atmosphere that produce acid aerosols whereas the largest ones tend to come from stack emissions of solid particles plus windblown mineral particles [4]. Table IV and VI show that particles with a small diameter have very small relaxation times, and short stop distances. If such particles pass a cyclone they will be separated from the larger particles. The alveolar fraction, e.g. can be sampled separately. Further, personal sample equipment exists, which sample all three fractions simultaneously. See e.g. <http://www.tsi.com/hsi/homepage/respicon/respspec.htm>

### *9.2.3. Impingers and impactors*

Impingers and impactors use the particle's momentum for collecting it. Impingers consist of glass nozzle submerged in a suitable liquid for collecting. The linear speed at the nozzle ranges from 60–13  $\text{m}\cdot\text{s}^{-1}$  [4]. Cascade impactors collect on a dry or reased slide. They contain a number of stages which progressive separation of smaller and smaller particles as the aerosol travels through the unit.

### *9.2.4. Bubblers*

The midget impinger is the most widely used of this type of instruments. When used as a bubbler in general, it is filled with 10–20 ml absorbing solution. The flow rate 1.0  $\text{dm}^3\cdot\text{min}^{-1}$ . A source of suction (for instance a personal pump) is connected to the outlet tube. The impinger is either hand-held or attached to the workers clothing [4].

### *9.2.5. Filters*

Filters remove particles from the air by a series of mechanisms. Interception of the particle by the filter material is important when the ratio of the particle size to the pore size is large. Inertial collection occurs when the airflow suddenly changes direction whereby the particles, which have more inertia, and therefore tends to keep the direction hit the surface of the filter. High air velocity and dense filter packing favour this mechanism. Diffusion is important for small particles. Diffusion is favoured by high particle concentration and low air velocity. The

efficiency increases with decreasing particles. For particles with a diameter below 0.01  $\mu\text{m}$ , however, particle rebound from the surface [20].

Electrical force might contribute substantially to collection efficiency. Data needed to predict the effect of electrostatic charges on collection efficiency, however, are seldom available [4].

Gravitational forces can be neglected except when wind air velocity is extremely low, for instance below 0.05  $\text{m}\cdot\text{s}^{-1}$  [4].

It is not always possible to have high collection efficiency for all particle sizes, because that would restrict the number of possible filters unacceptable for other reasons, e.g. cost, fragility, etc. It is of note that if the relevant measure of exposure is mass concentration, then it is important effectively to collect the larger particles as they contribute most to the total mass collected, whereas sub-micrometer particles only contribute very little. When number of particle, which will reach the alveoli compartment, is the relevant measure of exposure, large particles might be ignored.

Filters made by fibres of cellulose, glass, quartz, asbestos, and plastic of different compositions are commercial available. Other filters are made from sintered granular bead of glass, aluminium oxide, silver granules and (gel-type) membrane filters. Nucleopore filters are made by exposing a polycarbonate film for a flux of neutrons followed by etching the neutron tracks chemically.

TABLE XV: COMMON APPLICATION OF VARIOUS TYPES OF FILTERS. ADVANTAGES AND DISADVANTAGES

Filter type	Application	Advantages	Disadvantages
Membrane filters	sub-micron particle collection	High loading efficiency High mechanical strength	High pressure drop Rapid clogging
Cellulose Mixed esters nitrate, acetate, etc. and PVC	Sampling of metal, cotton dust, asbestos, etc. in NIOSH standard methods	Cheap Low chemical resistance	Hygroscopic Electrostatic charge build-up in PVC membranes
Teflon membranes	Gravimetric analysis, neutron activity analysis	Inert to chemicals non-hygroscopic Low blind value	Loss of nitrates observed
Silver membranes	Organic particulate collection and analysis.	Chemical resistant Low blind value	Very expensive

Application of a low-cost, dual-fraction dust sampler has recently been described [21]. The dust sampler measures both inhalable and respirable dust concentrations in a single sample, thus it saves both time and money. The best source of information about the properties and use of filters can be obtained from the suppliers of filters. Suppliers can be found on the Internet.

A study was carried out by Görner, et.al. [22] in which fifteen aerosol samplers were compared systematically. Of six inhalable aerosol samplers tested only one (RespiCon) was able to match the inhalable Convention fairly, using monodisperse solid particles with aerodynamic diameters ranging from 5 to 68  $\mu\text{m}$ . The other five samplers depended on wind speed, when wind speeds are above 0.5  $\text{m}\cdot\text{s}^{-1}$ , wind direction, and particle size [23].



### *9.2.6. Electrostatic precipitators*

The principle of electrostatic precipitators is to charge the particles and subsequently precipitate them in an electric field. In contrast to filter samplers, mass load does not affect sampling rate due to clogging.

Particles with a diameter larger than approximately 0.5  $\mu\text{m}$  have a too large inertia to be precipitated in this type of samplers. When sampling with electrostatic precipitators, adhesion is of primary importance because the electric force does not in general hold the dust onto the surface (Ref. [24]).

Maximum collection efficiency in a precipitator sampler is obtained applying high voltage. Visual examination can provide a useful indication of the collection efficiency. If sampling efficiency approaches 100%, there should be no significant deposit for the last few centimetres of the collector.

### *9.2.7. Thermophoretic precipitators*

The principle of thermophoretic precipitators is, that particles are precipitated when passing through a narrow channel, which has a temperature gradient of 1000–10000  $\text{K cm}^{-1}$  perpendicular to direction of flow. This method is useful for particles with diameters between approximately 0.01 and 0.5  $\mu\text{m}$ , because the thermophoretic velocity does not decrease with particle size. Sampling of particles with diameter larger than approximately 5  $\mu\text{m}$  is connected with upstream difficulties due to gravitational and inertial effects. Flow rate is usually between 10 and 1000  $\text{cm}^3 \cdot \text{minutes}^{-1}$ .

Thermal precipitators are not suitable for collecting volatile aerosol particles. Generally, thermal precipitators are useful aerosol devices, especially for sub-micron particles.

The advantages of thermophoretic samplers are that no alignment take place, which could distorts particle size determination, when analysing using a microscopes and that precipitation is so gentle that agglomerates seldom breaks up.

### *9.2.8. Diffusion batteries*

Particles are separated according to their diffusion coefficients by measuring the concentration of particles entering and leaving a tube or other similar conduit. Diffusion batteries are used for measuring the particle size distribution of sub micrometer particles with diameters of approximately 0.002 to 0.2  $\mu\text{m}$  [5].

Two types of diffusion batteries exist: 1) Single-stage diffusion batteries (based on rectangular channels or parallel circular plates) and 2) several stage diffusion batteries (cylindrical-tube and screen-type). Single-stage diffusion batteries can be used for measuring diffusion coefficients of mono-disperse aerosols at one flow rate.

In diffusion batteries a condensation nucleus counter in a sampling train is often used for detection of aerosol penetration.

### 9.2.9. *Passive personal dust sampler*

In this passive dust monitor are particles deposited by gravitation and Brownian and turbulent diffusion onto three transparent sticky foils facing upwards, forwards and downwards. After sampling, the foils are analysed by light extinction measurements or examined in a microscope [25]. Size and number distribution can be measured and the unbiased volume weighed diameter distribution can be calculated from the forward foil.

Airborne particles of all sizes are collected by this method. The monitor is for personal sampling and it is fixed in the breathing zone by use of a light harness. It is easily handled and the foils can be sent by mail and is thus suitable for self-administered studies.

### 9.2.10. *Direct reading instruments*

Direct-reading field instruments for aerosols measurements combine sampling and analysis.

#### 9.2.10.1. Piezoelectric sensor

Electrostatic precipitation particles are deposited on a piezoelectric sensor and particle mass is measured [26]. Rate of change of the resonant frequency of the sensor is directly proportional with the mass of material deposited on it. Short period slopes (24–120 seconds) can be analysed to measure concentration fluctuations. The instrument is capable of measuring particle mass concentrations as low as a fraction of a few  $\text{mg m}^{-3}$  at a sampling rate of  $1.0 \text{ dm}^3 \cdot \text{min}^{-1}$  over a 2 minute period [4].

#### 9.2.10.2. Beta-ray measurement

In this type of instrument the attenuation is directly related to the mass of collected particles in the beam. In the instrument, a  $^{14}\text{C}$  beta source is used in combination with a solid-state, silicon surface-barrier detector to measure the attenuated beta radiation.

#### 9.2.10.3. Light scattering

Two different types of instruments have been reported in Europe. The Safety in Mines Light Scattering Instrument (SIMSLIN) is a horizontal elutriator system (British), in which the aerosol is passed through the plates of a horizontal elutriator designed to have penetration characteristics matching the British Medical Research Council (BMRC) respirable aerosol curve. In the instrument the particles deposit on a filter. A time-weighted average of the respirable aerosol mass concentration can be obtained by weighing the filter at the end of a sampling shift. The aerodynamically selected aerosols enter an optical zone in which scattered infrared light (a diode laser) is collected and focused into a photodiode detector. The scattered light flux is reasonable proportional to particle mass concentration.

A different approach has been reported in Germany — the TM-Digital (Ref. [27]). This instrument has no pump and flow control system, the aerosols enters the sensing region due to the ‘natural’ convection in the workplace atmosphere. Scattered light from a parallel beam of monochromatic infrared light is detected at an angle of  $70^\circ$  to the forward-facing direction. In the TM-Digital instrument, sensing region is fully exposed to the workplace total aerosol, which is a drawback compared to the SIMSLIN. This can lead to contamination of the optical

surfaces by deposition of particles, resulting in drift if the instrument is used unattended over longer periods.

In the USA a corresponding instrument called Respirable Aerosol Monitor (RAM) exists. When used in combination with a cyclone pre-collector it is possible directly to measure the respirable fraction. By a pump the aerosol is lead through the cyclone, permitting only the respirable fraction to penetrate the optical sensing zone. Pulsed infrared light scattered in the angular range 45–90° from the forward direction is then collected and detected by a photodiode detector. Photodiode signal is approximately proportional to the respirable aerosol mass concentration [3].

A Mini-RAM (an extension of the RAM), has been developed. It is a passive device and like the TM-digital it responds to the respirable fraction. The instrument is small and can be used as a personal aerosol monitor.

Many such aerosol photometers, based on light scattering photometry are available. A more complete list is given in the ACGIH Handbook on air sampling instruments [4]. The above mention RespiCon measures the particle concentration continuously and simultaneously for each of the three fractions, besides it collects the total number of each fraction on filters for later analysis.

#### 9.2.10.4. Optical particle counters (light, lasers)

This technique is used for size distribution measurements. Particles are carried by an air stream through an illuminated viewing volume. The particles scatter the light, which is recorded by a photodetector. A voltage pulse is generated by the photodetector in response to each particle. The amplitude of the pulse is a measure of particle size diameter, which can be converted to the particle size distribution.

Counters using an incandescent light source are used for measuring size distributions in the range of 0.3–10 µm. By using lasers as light source, it is possible to measure size distributions down to as low as approximately 0.05 µm.

### 9.3. Determination of air volume

Accurate measurement of the air volume sampled is as important as an accurate determination of the sample quantity, because aerosol concentration is the ratio of the quantity sampled to the air volume sampled. Various methods exist, which can be classified into primary and secondary standards. Primary standards are those, which involve direct measurement of the physical dimension of an enclosed volume, i.e. SI units. Secondary standards are meters, which can be traced by their calibration to a primary standard.

TABLE XVI: AIR SAMPLING CALIBRATION METHODS

Type of meter	Quantity measured	Range
Spirometer	Integrated volume	6 – 600 dm <sup>3</sup>
Soap film flowmeter	Integrated volume	2 – 10000 cm <sup>3</sup>
Wet test meter	Integrated volume	0.5 – 230 dm <sup>3</sup> min <sup>-1</sup>
Dry test meter	Integrated volume	10 – 150 dm <sup>3</sup> min <sup>-1</sup>
Electronic mass flowmeter	Mass flow rate	0 – 3000 dm <sup>3</sup> min <sup>-1</sup>
Laminar flowmeter	Volumetric flow rate	0.02 cm <sup>3</sup> m <sup>-1</sup> – 1.0 m <sup>3</sup> min <sup>-1</sup>
Venturi meter	Volumetric flow rate	Depends on pipe and orifice diameters
Orifice meter	Volumetric flow rate	Depends on pipe and orifice diameters
Rotameter	Volumetric flow rate	from 1 cm <sup>3</sup> min <sup>-1</sup> up
Thermo anemometer	Velocity	from 0.3 m min <sup>-1</sup> up
Pitot tube	Velocity	from 300 m min <sup>-1</sup> up

Ref.[4]

### 9.3.1. Primary standards

#### 9.3.1.1. Spirometer

A spirometer is a cylindrical bell with its open end under water. The bell is balanced over a wheel with a counterweight. The volume entering the spirometer is determined by calculating the change in height times the bell's cross section.

#### 9.3.1.2. Soap film flowmeter

In this flowmeter a soap film acts as an almost frictionless piston. The time it takes for the soap film to travel between two marks on the cylindrical tube is measured. The pumping rate is determined by dividing the volume between the two marks with the travelling time.

#### 9.3.1.3. Pitot tube

Pitot tube is a primary standard for measuring gas velocity. Bernoulli's theorem applied to a Pitot tube in an air stream is:

$$v = (2gP_V/\rho_{Air})^{1/2} \quad (33)$$

where  $v$  is the linear velocity [m·s<sup>-1</sup>],  $P_V$  the velocity pressure = total pressure minus static pressure [Pa],  $g$  is the gravitational constant [m·s<sup>-2</sup>] and  $\rho_{Air}$  is the density [kg·m<sup>-3</sup>] of air. At STP the equation reduces to:

$$v = 1.2926(P_V)^{1/2} \quad (34)$$

where the velocity pressure is measured in Pa.

When using a U-tube manometer, the accuracy of the pitot tube is satisfactory for velocities above approximately 13 m·s<sup>-1</sup>. At lower velocities an inclined mano-meter is needed. Electronic capacitance pressure gauges permit measurements down to 0.5 m·s<sup>-1</sup> [4].

### 9.3.2. Secondary standards

#### 9.3.2.1. Wet test meter

The wet test meter consists of a cylindrical container in which there is a partitioned drum, half submerged in water. The air enters at the centre of the cylinder, the flow of which makes the drum rotate. The rotation and thereby the volume are measured. When calibrated against a spirometer the accuracy is below 0.5% [4].

#### 9.3.2.2. Dry test meter

The dry test meter is similar to that used for domestic gas metering. It consists of two bags connected by mechanical valves. One bag is filled while the other is emptied. The meter is equipped with a cycle-counting device. Flow rates can be measured from 5 to 5000 dm<sup>3</sup> min<sup>-1</sup> with an accuracy of 1%.

#### 9.3.2.3. Electronic mass flowmeter

A unit consist of a heating element in a duct situated between two points where the temperature is measured. The temperature difference depends on the mass rate of the air and the heat input.

#### 9.3.2.4. Laminar flowmeter

The pressure drop is directly proportional to the flow rate in the laminar flow type of variable-head meters. In commercial flowmeters laminar flow restrictors consist of egg-crate or tube bundle arrays of parallel channels. Alternatively a homemade kind of flowmeter can be constructed in the laboratory (Ref. [4]) using cheap materials.

#### 9.3.2.5. Fixed restricted flowmeters

This includes orifice and venturi meters and flow nozzles. If the flow in a closed channel is passing a fixed constriction it follows from Bernoulli's theorem that

$$W = q_1 \rho_1 = KYA_2 \rho_1 [2 (P_1 - P_2)]^{1/2} \quad (35)$$

which apply for both orifice and venturi meters.  $W$  is the mass rate [kg·s<sup>-1</sup>],  $q_1$  the volumetric flow at upstream pressure [m<sup>3</sup>·s<sup>-1</sup>],  $\rho_1$  is density at upstream pressure,  $K = C/(1-\beta^4)^{1/2}$ , where  $C$  is the coefficient of discharge, dimensionless (Ref. [28]),  $\beta$  is the ratio of throat diameter to pipe diameter, dimensionless,  $Y$  is the expansion factor, dimensionless [28],  $A_2$  is the cross-sectional area of the throat [m<sup>2</sup>],  $P_1$  is the upstream static pressure [Pa], and  $P_2$  is the downstream static pressure [Pa]. This equation should be used with cautions, because it is sometimes difficult to determine the actual coefficient for a given system.

### 9.3.2.6. Orifice meter

An orifice meter should always be calibrated against a primary or secondary reference instrument.

### 9.3.2.7. Venturi meter

The Venturi meter minimizes the energy loss found in the orifice meters by using a converging (21°) and diverging (5 – 15°) cone before and after the orifice.

At STP, the flow  $Q$  [ $\text{dm}^3 \text{min}^{-1}$ ] can be calculated from:

$$Q = 5.897 \beta^2 D^2 (\Delta h)^{1/2} \quad (36)$$

where  $\beta^2$  is the ratio of throat to pipe diameter,  $D$  the pipe diameter [cm], and  $\Delta h$  the difference pressure [Pa].

### 9.3.2.8. Rotameter

Rotameter are the most commonly used apparatus for metering volumetric airflow rates. They consist of a float, which is free to float up and down in a tube, which is wider at the top than in the bottom. The higher the airflow rate, the higher up the float will be. Accuracies down to 1–2% can be obtained, when the rotameters are calibrated in the system. A rotameter used in the workplace must always be calibrated on the spot, because rotameters are very sensitive to differences in temperature and pressure [4]:

$$Q_{Site} = Q_{STP} [(T_{Amb}/T_{STD})(P_{STD}/P_{Amb})(P_{Amp}/P_{Rota})]^{1/2} \quad (37)$$

where  $Q_{Site}$  is the rotameter reading,  $Q_{STP}$  the flow rate at STP (20°C, 101325 Pa),  $T_{Amb}$  is the ambient temperature,  $T_{STD}$  is the standard temperature (293.15 K),  $P_{STD}$  is the standard pressure (101325 Pa),  $P_{Amb}$  is the ambient pressure on-site [Pa], and  $P_{Rota}$  is the pressure at the rotameter inlet.

Correction is needed to correct for pressure drops over the sampler, high altitudes and temperatures deviating from 293.15 K.

At an elevation of 1524 m, the atmospheric pressure is only 83% of the pressure at sea level. If the temperature at site is 35°C, the correction will be:

$$\begin{aligned} C_{Temp} C_{Altitude} C_{PressureDrop} &= \left[ \left( \frac{273.15 + 35}{293.15} \right) \left( \frac{101325}{0.83 \cdot 101325} \right) \left( \frac{0.83 \cdot 101325}{0.83 \cdot 101325 - 25000} \right) \right]^{0.5} \\ &= 1.025 \cdot 1.098 \cdot 1.196 = 35\% \end{aligned} \quad (38)$$

for a pressure drop over the sampler of 25000 Pa. It is of note that at a temperature as high as 35°C only increases the flow rate with 2.5% and an elevation to 1524 m above sea level increases the flow rate with 9.76%. The pressure drop over the sampler of 25000 Pa increases the flow rate with 15.2% at sea level and 19.6% at 1524 m.

### 9.3.2.9. Thermo anemometer

In a hot wire anemometer, the flow cools the sensor (a wire) proportional to the velocity of the air. Because the signals produced by the basic sensor are dependent on ambient temperature as well as air velocity, the probes are usually equipped with a reference element that provides an output, which is used for corrections. Some heated anemometers can measure velocities as low as  $0.05 \text{ m}\cdot\text{s}^{-1}$  and as high as  $40 \text{ m}\cdot\text{s}^{-1}$  [4].

## 10. DISCUSSION

In mines during excavation of minerals, during the building of houses, bridges, and roads, in many lines of manufacturing industry are workers exposed to airborne solid particles in the form of dust, smoke and fumes. Solid particles are created, e.g. by crushing, grinding, milling, and welding.

The dynamic behaviour of solid airborne particles, the size of which roughly ranges from 0.01 to  $100 \mu\text{m}$  in diameters, has been described with a set of equations given in the method section of this paper. The mathematical manipulation of the equations has been kept at a minimum; instead transport properties are illustrated by a series of calculations for aerosols consisting of water, minerals, and uranium.

External forces due to gravimetric and electrostatic fields and gradients in temperature and concentration influence particles. Viscous forces act on particles when they are moving relative to the encompassing air.

When air experiences a laminar flow, the layers of air slide over each other. Turbulent flow is air which flow in eddies. At the workplace, transport is mainly due to turbulent eddies of air caused by movements of machines and vehicles, air moving due to heat radiation from machines, humans, and cold walls and windows. Further, wind may blow from open gateways, doors and windows.

Particles are removed from the workroom air due to sedimentation and adhesion to the workplace's surfaces. For large particles gravimetrical sedimentation is much order of magnitudes faster than deposition due to diffusion. For small particles deposition due to diffusion is dominating. A mineral particle with a diameter of  $100 \mu\text{m}$ , falling from the ceiling of a six-meter high room, will in stagnant air reach the floor within 6.6 seconds. A one- $\mu\text{m}$  particle will reach the floor after 16 hours and for a  $0.01\text{-}\mu\text{m}$  particle it will take 334 days.

Number of particles in the air is reduced by particles agglomerating, leading to larger particles, with increased sedimentation velocity. Time to halve the number concentration is  $30 \mu\text{s}$  for  $1\text{-}\mu\text{m}$  particles, when the start concentration is  $10^{20}$  particles per  $\text{m}^3$ , but when the start concentration is  $10^8$  it will take 343 days. When the start concentration is  $10^{20}$ , will it take  $208 \mu\text{s}$  to double the particle size, when the start concentration is  $10^8$ , it takes 7 years. For the purpose of sampling, agglomeration may be ignored at number concentrations below  $10^{12}$ .

The airflow in the human nose/mouth, the throat, and the bronchial region is turbulent, whereas the airflow in the alveoli is laminar. The small relaxation times for particles the short stopping distances indicate that deposition in the upper airways is mainly by impact for the

particles with aerodynamic diameters above 10  $\mu\text{m}$ . Particles with aerodynamic diameters below 2.5  $\mu\text{m}$  may reach the alveoli. The largest of the particles, which reach the alveoli, deposit due to gravity, the smallest deposit due to diffusion and action of electrical forces. The function of mass percent deposited as function of the aerodynamic diameter, therefore, passes through a minimum.

A single paper deals with the ability of occupational hygienist to assess aerosol concentrations by observation [19]. The conclusion of this paper was that it is not possible to assess exposure to aerosol by observation. If workers' exposure to solid particles, therefore, is to be assessed, the concentration of particles must be measured in the air they inhale.

The weak link in aerosol measurements is the sampling procedure, because no sampling devices can mimic the way human beings are breathing. Further, for the individual worker, the breathing pattern varies from day to day depending, e.g. on the workload and it varies between people. International conventions have established definition of the inhalable, the thoracic, and the alveolar fractions of an aerosol. The aim is that sampling devices should sample in accordance with these conventions.

Many sampling devices have been invented, which more or less comply with the given conventions, but their performance is not independent of the nature of the aerosol sampled. No single sampling equipment and no single procedure will be the best to use in all cases.

The range 0.01–100  $\mu\text{m}$  is four decades. On a macroscopic scale four decades correspond to 1 cm–100 m. Obviously, a scale rule suitable to measure one cm would not be suitable for measuring 100 m. It is no wonder, therefore, that development of sampling devices which can cover four decades has been very difficult. Of six inhalable aerosol samplers tested, only one (RespiCon) was able to match the Inhalable Convention fairly, using monodisperse solid particles with aerodynamic diameters ranging from 5 to 68  $\mu\text{m}$ . The other five samplers depended on wind speed, when wind speeds are above 0.5  $\text{m s}^{-1}$ , wind direction, and particle size

The theoretical background given in this paper, the performance of the sampling devices considered, combined with knowledge about the nature of the aerosol and which compartment in the human airways is of concern, must, in each measurement situation, be judged separately. Help can be found, e.g. on the Internet. Useful World Wide Web addresses are given at the end of the reference list.

Occupational limit limits are based on mass. It is doubtful whether this measure of exposure in all cases is appropriate. Dose measured as number of particle deposited per day or surface area may sometime be more associated with risk. When sampling dust in which the composition of toxic and/or radioactive varies with particle diameter, dose calculated on a mass basis is inappropriate.



## 11. CONCLUSIONS

Following statements about solid aerosols in general can be drawn:

- In the workplace particles are created by different kinds of processes e.g. crushing, grinding, milling, using diesel-powered motors, and welding. Aerosols produced are typically with a diameter from 0.01 to 100  $\mu\text{m}$ .
- In the workplace particles are removed from the air due to sedimentation and adhesion to surfaces. Particles with aerodynamic diameter above 10  $\mu\text{m}$  are mainly deposited due to gravity. Small particles with aerodynamic diameter below approximately 0.2  $\mu\text{m}$  mainly deposit due to diffusion and action of electrical forces. Number of particles in the air is reduced by agglomeration. This phenomenon may be ignored, when number concentrations are below  $10^{12}$  particles per cubic meter.
- The air in the nose/mouth, the throat, and the bronchial region the air flow is turbulent, whereas the airflow in the alveoli is laminar
- Particles are inhaled and deposited in the different part of the human respiratory system due to the airflow patterns prevailing and the aerodynamic properties of the particles.
- Large particles (aerodynamic diameter  $> 10 \mu\text{m}$ ) are deposited in the upper airways mainly due to impaction. The largest of the particles, which penetrate to the alveoli compartment (aerodynamic diameter 1–2.5  $\mu\text{m}$ ) deposit due to sedimentation, whereas the smallest particles (diameter 0.1–0.01  $\mu\text{m}$ ) mainly deposit due to diffusion and action of electrostatic forces.
- Sampling procedure of aerosols is a difficult task to handle. It has to mimic the breathing pattern of human beings as good as possible. Other components will influence and have to be considered for instance changes in breathing tempo and the nature of the aerosol sampled.
- International conventions are established for sampling of airborne particulates. Dose measured as number of particle deposited per day or surface area may sometime be more closely associated with risk than dose based on mass. If the dust sampled consists of particles the composition of which varies with size, dose calculated on a mass basis is inappropriate.

## ACKNOWLEDGEMENT

This report has been conducted under the IAEA Technical Contract No 10979/Regular Budget Fund.

## REFERENCES

- [1] EUROPEAN COMMITTEE FOR STANDARDIZATION (CEN), "Workplace Atmospheres — Size fraction definitions for measurement of airborne particles", CEN Standard EN 481 (1993).

- [2] WILLEKE, K., AND BARON, P.A., Aerosols measurement, Van Nostrand Reinhold: New York (1993).
- [3] VINCENT, J.V., Aerosol Science for Industrial Hygienists, 1th Ed. (1995).
- [4] COHEN, B.S., HERING, S.V., Air sampling instruments for evaluation of atmospheric contaminants, American Conference of Governmental Industrial Hygienists: Cincinnati, (1995).
- [5] HINDS, W.C., Aerosol Technology, 2nd Ed. (1999).
- [6] EVANS, M., PRISTON, R., TODOIR, W., The Health Effects including of PM<sub>2.5</sub> (including ultrafine particles) report no. 99/60 (1999), Concawe, Brussels.
- [7] CUNNINGHAM, E., On the velocity of steady fall of spherical particles through fluid medium, Proceedings of the Royal Society **A83** (1910) 357.
- [8] DAVIES, C.N., Particle Fluid Interaction, J.Aerosol Sci. **10** (1979) 477.
- [9] JOHNSTON, A.M., VINCENT, J.H., JONES, A.D., Measurements of electric charge for workplace aerosols, Ann. Occup. Hyg. **29** (1985) 271.
- [10] SCHNEIDER, T., Teknisk Arbejdshygiejne (Danish: Occupational Hygiene), (1996).
- [11] WEIBEL, E.R., Morphometry of the Human Lung (1963), Heidelberg, Springer Verlag.
- [12] ANNALS OF THE ICRP, Human Respiratory Tract Model for Radiological Protection. ICRP Publication 66, Pergamon, Elsevier Science Ltd. **24** (1993).
- [13] COX, R.G., The motion of long slender bodies in a viscous fluid, J.Fluid Mechanics **44** (1970) 791.
- [14] STÖBER, W., A note on the aerodynamic diameter and mobility of non-spherical aerosol particles, J.Aerosol Sci. **2** (1971) 453.
- [15] FRY, F.A., Charge distribution of polystyrene aerosols and deposition in the human nose, J.Aerosol Sci. **1** (1970) 135.
- [16] YU, P.C., Theories of electrostatic lung deposition of inhaled aerosols, Ann.Occup.Hyg. **29** (1985) 219.
- [17] PETERS, A., WICHMANN, H.E., TUCH, T., Respiratory effects are associated with the number of fine particles, Am.J.Respir.Crit.Care Med. **155** (1997) 1376.
- [18] DONALDSON, K., STONE, V., CLOUTER, A., RENWICK, L., MACNEE, W., Ultrafine particles, Occup. Environ. Med. **58** (2001) 211.
- [19] WOITOWITZ, H.J., SCHÄCKE, G., WOITOWITZ, R., Rangmässige Schätzung der Staubexposition und Arbeitmedizinische Epidemiologie, Staub-Reinheit Luft **10** (1970) 419 (in German).
- [20] WANG, H.C., KASPAR, G., Filtration efficiency of nanometer-sized aerosol particles, Aerosol Sci.J. **9** (1991) 291.
- [21] KENNY, L., CHUNG, K., DILWORTH, M., HAMMOND, C., WYNN JONES, J., SHREEVE, Z., WINSTON, J., Applications of Low-Cost, Dual-Fraction Dust Samplers, Ann.Occup.Hyg. **45** (2001) 35.
- [22] GÖRNER, P., WROBEL, R., MICKA, V., SKODA, V., DENIS, J., FABRIES, J.-F., Study of Fifteen Respirable Aerosol Samplers Used in Occupational Hygiene, Ann.Occup.Hyg. **45** (2001) 43.
- [23] LI, S.N., LUNDGREEN, D.A., ROVELL-RIXX, D., Evaluation of six inhalable aerosol samplers, Am.Ind.Hyg.Assoc.J. **61** (2000) 506.
- [24] PENNEY, G.W., Role of Adhesion in Electrostatic Precipitation, Arch.Environ.Health **4** (1962) 301.
- [25] VINZENTS, P.S., A passive personal dust monitor, Ann.Occup.Hyg. **40** (1996) 261.
- [26] TSI, Inc., Model 3500, Respirable Aerosol Mass Monitor, Piezobalance, TSI, Inc.St.Paul, MN (2001).

- [27] ARMBRUSTER, L., BREUER, H., Dust monitoring and the principle of on-line dust control (1983) 689.
- [28] PERRY, J.H., et.al., Chemical Engineering Handbook, 6th Ed. (1984).

## APPENDIX I RELATED CD-ROM, WEB PAGES, FILTERS

### CD-ROM

Asgharian, B. et al. Multiple Path Particle Deposition model (MPPDep version 1.11). A model for human and rat airway particle deposition, CIIT (1999)

### SOME WEBPAGES

<http://www.ajabrams.com>  
<http://www.acgih.org>  
<http://www.aiha.gov>  
<http://www.aiha.org/abs00/0airsam.html>  
<http://www.aiha.org/abs00/abindx.html>  
<http://www.ami.dk>  
<http://www.astm.gov>  
[http://www.bygd.com/search/Basic\\_Laboratory\\_Equipment/](http://www.bygd.com/search/Basic_Laboratory_Equipment/)  
<http://www.cdc.gov/NIOSH/>  
<http://www.dustmonitor.com>  
<http://www.efunda.com/formulae/fluids/>  
<http://www.environmentalrental.com>  
[http://www.genevue.com/A\\_Diffus/Jav1\\_2.html](http://www.genevue.com/A_Diffus/Jav1_2.html)  
<http://www.google.com>  
<http://www.gnet.org/doe>  
<http://www.hund.de>  
<http://www.isi.com>  
<http://www.lanl.gov>  
<http://www.niwt.se>  
<http://www.osha.sic.gov>  
[http://www.osha-slc.gov/dts/osta/otm/otm\\_ii/otm\\_ii\\_1.html](http://www.osha-slc.gov/dts/osta/otm/otm_ii/otm_ii_1.html)  
[http://www.phys.virginia.edu/classes/109N/more\\_stuff/Applets/brownian/applet.html](http://www.phys.virginia.edu/classes/109N/more_stuff/Applets/brownian/applet.html)  
<http://www.skcinc.com/skc.html>  
<http://www.tsi.com>  
[http://www.tsi.com/hsi/homepage/respicon/resp\\_faq.htm](http://www.tsi.com/hsi/homepage/respicon/resp_faq.htm)  
<http://www.msanet.com>  
<http://www.nist.gov>  
<http://www.mit.edu/>  
<http://www.astm.org>  
<http://www.acgih.org>  
<http://www.msha.gov>  
<http://www.anderseninstruments.com/>  
<http://www.envirosources.com>  
<http://www.petropages.com>  
<http://www.mieinc.com/>

<http://www.mil-ram.com/>  
<http://www.apbuck.com>  
<http://www.metone.com>  
<http://www.grimm-aerosol.de>  
<http://www.sba.gov/sbir/tibbetts/msp.html>  
<http://www.micromagazine.com/company/co/110/11001.html>  
<http://www.rpco.com>  
[http://www.epa.gov/docs/OPPTS\\_Harmonized/830\\_Product\\_Properties\\_Test\\_Guidelines/Series/830-7520.pdf](http://www.epa.gov/docs/OPPTS_Harmonized/830_Product_Properties_Test_Guidelines/Series/830-7520.pdf)  
<http://www.aqd.nps.gov/ard/vis/sop/ti176b.pdf>

## FILTERS

<http://www.old.fishersci.com/aboutus/ftimeline7.jsp>  
<http://www.pall.com/gelman/lifesci/venting.asp>  
<http://www.hollingsworth-voese.com>  
<http://www.millipore.com/>  
<http://guide.labanimal.com/company/247.html>  
 Nuclepore Corporation, 7035 Commerce Circle, Pleasanton, California 94566  
<http://www.sartorius.com/>  
<http://www.s-und-s.de/english-index.html>  
<http://www.whatman.plc.uk>

## APPENDIX II

### LIST OF SYMBOLS

$C_D$	Drag coefficient. $C_D = 24/Re$ for $Re < 1$ . $C_D = \frac{24}{Re} \left( 1 + \frac{Re^{2/3}}{6} \right)$ for $Re \in [1, 1000]$ . $C_D \sim 0.44$ for $Re \in [1000, 2 \cdot 10^5]$
$C_{Slip}(d)$	Slip correction factor. When small particles ( $d < 1 \mu\text{m}$ ) settle, they do it faster than predicted by Stokes law, by a factor of $C_{Slip}(d)$ , because there is a “slip” at the surface of the particles.
$D$	Diffusion coefficient in air: Air = $1.99 \times 10^{-5} \text{ m}^2 \cdot \text{s}^{-1}$ at STP (Hinds, 1999).
$d_{Air}$	Diameter of air molecules at STP = $0.00037 \mu\text{m}$ (Hinds, 1999).
$d_{c-c}$	Collision diameter, distance between the centres of two particles at the instant of collision. Air: $3.7 \times 10^{-10} \text{ m}$
$E_{Inhalable}$	Fraction of an aerosol, which will penetrate to the Exthoracic Compartment.
$E_{Thoracix}$	Fraction of an aerosol, which will penetrate to the Thoracic Compartment.
$E_{Aveoli}$	Fraction of an aerosol, which will reach the Alveoli Compartment.
$F_G$	Force due to gravity = $mg = m \, dv/dt$ [N]
$F_{Drag}$	Force due to drag = $C_D \rho_{Air} \left( \frac{\pi}{4} \right) d^2 v \phi / C_{Slip}(d)$ [N]
$g$	Constant of gravity = $9.81 \text{ m s}^{-2}$
$k$	Boltzmann's constant = $R/N_A = 8.3143 \text{ J} \cdot \text{K}^{-1} \cdot \text{mol}^{-1} / 6.02 \times 10^{23} \text{ molecules mol}^{-1} = 1.3811 \times 10^{-23} \text{ J} \cdot \text{K}^{-1} \cdot \text{molecule}^{-1}$
$M_{Air}$	$0.028964 \text{ Dalton (kg} \cdot \text{mol}^{-1})$

$m$	Mass of air molecules = $M_{Air}/N_A = 0.029 \text{ kg}\cdot\text{mole}^{-1}/6.02\times 10^{23}$ molecules $\cdot\text{mole}^{-1} = 4.8\times 10^{-26} \text{ kg}\cdot\text{molecule}^{-1}$
$mfp$	Mean free path: the average distance travelled between successive collisions = $\frac{\bar{v}}{n_c} = \frac{1}{\sqrt{2} n \pi d_{c-c}^2}$ . For air at STP: $mfp_{Air} = 6.6\times 10^{-8} \text{ m}$ .
$N$	Number of particles
$N_A$	Avogadro's number: number of molecules in a mole = $6.02\times 10^{23}$ molecules $\cdot\text{mole}^{-1}$
$n$	Number of particles or molecules per $\text{m}^3$ . At STP: $n_{Air} = 2.5\times 10^{25}$ molecules $\text{m}^{-3}$
$n_c$	Number of collisions per second = $\sqrt{2} n \pi d_{c-c}^2 \bar{v}$ [Collision $\text{s}^{-1}$ ]
$P$	Pressure [Pa]
$Re$	Reynolds number = $d v \rho / \mu$
$Re_p$	Reynolds number for particle $p = d_p v_p \rho_p / \mu_{Air}$
$STP$	One atmosphere (101325 Pa), 20 °C
$u$	Random velocity [ $\text{m}\cdot\text{s}^{-1}$ ]
$u_{ms}$	Mean squared random velocity [ $\text{m}\cdot\text{s}^{-1}$ ]
$v$	Velocity [ $\text{m}\cdot\text{s}^{-1}$ ]
$\bar{v}$	Mean molecular velocity = $\left(\frac{8kT}{\pi m}\right)^{0.5} = \left(\frac{8RT}{\pi M}\right)^{0.5}$ . The molecular velocity of water vapours, $\text{CO}_2$ , and air are 637, 407, and 503 $\text{m}\cdot\text{s}^{-1}$ at 20°C, respectively (Hinds, 1999).
$V$	Volume [ $\text{m}^3$ ]
$\phi$	Form factor (= 1.00 for a sphere)
$\rho$	Density [ $\text{kg}\cdot\text{m}^{-3}$ ]
$\rho_{Air}$	Density of air = 1.205 $\text{kg}\cdot\text{m}^{-3}$
$\rho_p$	Density of particles: (1000 $\text{kg}\cdot\text{m}^{-3}$ (water), 3000 $\text{kg}\cdot\text{m}^{-3}$ (minerals), 18950 $\text{kg}\cdot\text{m}^{-3}$ (uranium))
$\rho_{Air}$	Density of air at STP = 1.2041 $\text{kg}\cdot\text{m}^{-3}$
$\mu_{Air}$	Viscosity of air at STP = $\frac{2(m k T)^{0.5}}{3 \pi^{1.5} d_{c-c}^2} = 1.81 \cdot 10^{-5} \text{ Pa}\cdot\text{s}$ . It is counter intuitive that viscosity of gases is independent of pressure, but this has been experimentally verified under pressures from 0.001 to 100 atmospheres (Hinds, 1999). Further, the viscosity of a gas increases with temperature, in contrast to the viscosity of a liquid.

# CHARACTERIZATION OF AIRBORNE Ce, Th AND Cd IN WORKPLACE AND THEIR CO-RELATION WITH THEIR CONCENTRATIONS IN BODY FLUIDS AND EXCRETA OF OCCUPATIONAL WORKERS USING NAA, ICP-AES AND XRF

P.M.B. PILLAI<sup>1</sup>, S. RADHAKRISHNAN<sup>1</sup>, C.G. MANIYAN<sup>1</sup>, P.P. HARIDASAN<sup>1</sup>, B.S. NEGI<sup>2</sup>, M.G. NAIR<sup>3</sup>, P. SAWANT<sup>3</sup>, A. KUMAR<sup>4</sup>, N. KRISHNAN<sup>4</sup>

<sup>1</sup> Health Physics Unit, Environmental Radiological Laboratory (BARC), Kerala, India

<sup>2</sup> Environmental Assessment Division, BARC, Mumbai, India

<sup>3</sup> Biokinetics and Bioassay Section, Health Physics Division, BARC, Mumbai, India

<sup>4</sup> Radiation Safety Systems Division, BARC, Mumbai, India

## Abstract

Measurements of the airborne concentrations of thorium (Th) and Cerium (Ce) and their size characterization were carried out in beach mineral separation and monazite processing plants. Size characterization of airborne dust and elemental concentrations of the dust was also carried out at a Zinc Smelter Unit. Further studies were conducted on elemental distribution of different size fractions of the Airborne Particulate Matter (APM) as also the leaching characteristics of the elements. The levels of Th and Ce in urine samples of occupational workers were discussed in relation to their airborne concentrations and chemical speciation. A limited number of blood samples collected from occupational workers in monazite processing plant were also analysed for Th and Ce content. The results of Thoron ( $^{220}\text{Rn}$ ) in breath measurements and urine analysis (Th) with respect to two groups of occupational workers with history of chronic exposure to airborne mineral dust and thorium from the mineral separation and chemical processing of monazite at the Mineral Separation Plants (MSP) and Monazite Chemical Processing Plant (MCP) were studied in relation to their exposures. A group of adults of comparable age group from a Natural High Background Radiation Area (NHBRA) were also subjected to the measurements in order to estimate the environmental contribution specific to NHBRA where the MSPs are located. Monitoring of aerosols released during the processing of zinc ore have shown that 85% of the airborne dust released are above 9  $\mu\text{m}$  Mass Median Aerodynamic Diameter (MMAD) at the initial stages. However the MMAD at the down stream processing was about 3  $\mu\text{m}$ . The elemental concentrations and their ratios in the raw material were reflected in the APM at the initial stages. Detailed size characterization studies showed that up to 50% of APM was below 2  $\mu\text{m}$  in some process areas. Elemental concentrations of Cd and Zn exceeded the Threshold Limit Values (TLVs) at some of the locations in this plant and the situation calls for regular monitoring. In the mineral beneficiation plants the Activity Median Aerodynamic Diameter (AMAD) of the particulates ranged from 2.7 to 15  $\mu\text{m}$  with an average of 7  $\mu\text{m}$ ., Geometric Standard Deviation (GSD) varied from 2.6 to 4.6. Based on the ICRP dose conversion factors and taking into consideration the equilibrium status of  $^{232}\text{Th}$  and  $^{228}\text{Th}$  in monazite, a combined Annual Limit of Intake for Th of 534 Bq and corresponding Derived Air Concentration (DAC) of 0.22 Bq/m<sup>3</sup> are arrived at for the mineral processing plants. In the plant processing monazite the AMAD of airborne particulates were in the range 2.1 to 9.0  $\mu\text{m}$  (mean =  $4.5 \pm 1.9$   $\mu\text{m}$ ). The corresponding combined ALI ( $^{232}\text{Th}$  and  $^{228}\text{Th}$ ) works out to 385 Bq for unspecified compounds of thorium (DAC = 0.16 Bq/m<sup>3</sup>). The airborne concentrations of Th, Ce, Cd and Zn are compared with the TLVs, ALI and DAC values as applicable to assess the health effects of airborne particulate matter in the industries studied.

## 1. INTRODUCTION

Considerable amount of data exist with regard to the exposure, metabolism and health effects of Cd. In human exposure the two main target organs are the kidney and the lung. One of the major source of occupational exposure is smelting and refining of zinc, the major route of absorption being inhalation of aerosols and fumes. The degree of pulmonary absorption depends on the particle size and solubility of the airborne Cadmium compounds [1]. Studies were carried out at a Zinc Smelter plant to assess the occupational inhalation hazards due to Airborne Particulate Matter (APM). The plant is engaged in the production of Zinc ingots and Cadmium metal from Zinc blend. The process involves grinding, roasting, H<sub>2</sub>SO<sub>4</sub> dissolution followed by electrolysis and smelting. The size characteristics of airborne dust and elemental distribution of Zn & Cd at different size fractions of the APM were carried out at the Zinc smelter Plant [2, 3]. The present study deals with the concentrations of airborne dust and its elemental contents and compares them with the threshold limit values (TLV) for Cd and Zn.

Inhalation of airborne particles of monazite and thorium compounds are the major route of occupational internal exposures in the mineral processing plants and monazite processing plants. The important factors which influence the inhalation dose are (a) particle size distribution of the aerosols (b) solubility and particle transport of the inhaled aerosols and (c) the radioactivity concentrations. Particle sizes of aerosols are described by the activity median aerodynamic diameter (AMAD) and mass median aerodynamic diameter (MMAD) with the relevant geometric standard deviation (GSD). The ICRP 66 human respiratory tract model provides regional deposition fractions for aerosols having log normal distribution in five regions of human respiratory tract (ET1, ET2, BB, bb and AI), for particle sizes ranging from 0.0006 µm to 100 µm AMAD [4]. The annual limit of intake (ALI) and derived air concentration (DAC) specific to minerals separation are arrived at using the ICRP methodology. The studies were carried out in two mineral separation plants (MSP) and a monazite chemical processing plant (MCP) in South India. The plants separate ilmenite, monazite, rutile, zircon etc from the beach minerals. The physical separation of the different mineral is achieved by utilizing their differences in electrical properties, magnetic properties and specific gravities. Studies were carried out during the early nineties (1989–90) on size distribution of airborne dust and radioactivity in the above MSPs [5]. The mineral separation process has undergone changes with the introduction of dredge mining and wet concentration processes [6]. These steps have resulted in substantial reduction in the quantity of dust in the feed material and airborne particulates in the process areas, which necessitated re-evaluation of the inhalation hazards in the plants. At the monazite processing plant powdered monazite is subjected to caustic soda digestion and selective extraction with hydrochloric acid to separate Th and the rare earths. Different chemical forms of Th and rare earth elements (mainly Ce) are handled in this plant.

Assessment of Th and Ce in the work atmosphere and its concentration in body and excreta of occupational workers help to estimate the internal exposures. Considerable uncertainty exist in the urinary concentrations reported and interpreted by various workers [7, 8, 9]. The present work analyse the results of Thoron (<sup>222</sup>Rn) in breath measurements and urine analysis (Th) with respect to two groups of occupational workers with history of chronic exposure to airborne thorium and mineral dust from the mineral separation and chemical processing of monazite at the MSP and MCP. A group of adults of comparable age from the natural high background radiation area (NHBRA) were also subjected to the measurements in order to estimate the environmental contribution specific to NHBRA where the MSPs are located.

## 2. MATERIALS AND METHODS

### 2.1. Sampling of Airborne Particulate Matter (APM)

Sampling for gross APM was carried out using 2.5 cm open faced air sampling heads and a suction pump of capacity 60 Lpm. Personal air samples were collected using Casella Vortex Personnel Air Sampling Pump. Pre-conditioned weighed Whatman 41/GFA filters were used for the sampling. From the weights of APM collected the airborne concentrations of dust were determined. Sampling durations were typically in the range of 1 to 8 hours in order to collect sufficient quantity of dust particles. Samples were collected from different locations in the plants at a height of 1 m above the ground. Environmental air samples are collected on GFA filter using high volume samples of 1.2 m<sup>3</sup>/min for duration ranging from 6– 10 hrs. An eight-stage Anderson Cascade Impactor Sampler, was used for the size characterization of aerosols [2]. The filters are counted in low background alpha counters (overnight counting). One sixth of the gross alpha activity is taken as due to <sup>232</sup>Th assuming secular equilibrium between <sup>232</sup>Th and its decay products. Self absorption correction is applied for the dust loading on the filter.

### 2.2. Elemental characterization of Zn, and Cd in APM

Filters for estimation of Cd and Zn were treated with analar 12M HNO<sub>3</sub> to destroy the organic matter and the residual mass was leached with 9M H<sub>2</sub>SO<sub>4</sub> [3]. Filters, used only as blank accompanied every set of sample and the standard. The leach solutions were filtered and analysed in an Inductively Coupled Plasma — Atomic Emission Spectrometer (ICP-AES) Model Labtam — 8440M.

### 2.3. Determination of Th and Ce content in APM

The air samples collected were stored for a period of three weeks for the short lived radioactivity due to Radon and Thoron daughter products to decay. Long lived alpha activity on the samples were counted in a low background alpha counter using a ZnS (Ag) scintillation detector (ECIL Model RCS, 4027A) having an efficiency of 30% and background count rate of 6 counts per hour. Cerium has a fixed ratio to Th (Ce/Th=2.9) in the monazite mineral and hence the thorium value arrived at by alpha counting can be advantageously used to estimate Ce indirectly. Composite air samples were analysed by gamma spectrometry also to estimate the Th content.

### 2.4. Solubilisation studies using lung-serum simulant

The air filters loaded with the airborne particulate matter were subjected to leaching studies using lung-serum simulant [10]. The APM collected in air filters from process areas were placed inside the perforated perspex holder [2]. This was kept immersed in the lung-serum simulant (1 litre) solution kept in a 2 L glass beaker. The leaching temperature was kept constant at 37°C throughout the experiment in an incubator. Aliquots of 100 mL of the samples were drawn from the beaker at different time intervals. Each time the lung serum simulant was replenished with 100 mL lots of fresh solution. A blank (with unexposed filter papers) was run at identical conditions. The solutions drawn from the beakers were filtered through Whatman 41 filters using a suction device. The filtered samples were analysed by low background alpha counting/NAA/ICP-AES.



## 2.5. Thoron-In-Breath Measurements

Thoron-In-Breath Measurements (TIBM) were carried out using a large Double filter unit (DF) with a delay volume [11]. The subjects breathe thoron ( $^{220}\text{Rn}$ ) free air and their exhaled breath is drawn through a 150 L chamber (Double Filter Unit). The decay products in the exhaled thoron are collected at the exit filter of the system. Thoron emanation is determined by alpha counting of the exit filter over long durations in a low background counter.

## 2.6. Collection and analysis of urine samples

Overnight urine samples collected from the subjects are wet ashed with  $\text{HNO}_3$ . Calcium phosphate is precipitated in the samples using Ca carrier (50 mg Ca as  $\text{CaCl}_2$ ) and adjusting pH to 11 by slow addition of  $\text{NH}_3$  solution. The samples are kept overnight for settling. The supernatant solution is decanted out and the precipitate is dissolved in minimum quantity of 5 M HCl. To this solution 10 mL of 1 M oxalic acid is added to precipitate calcium oxalate. The precipitate is analysed for Th and Ce by Neutron Activation Analysis (NAA) [12, 2].

## 2.7. Collection and analysis of blood samples

10 mL of blood samples were drawn from occupational workers (exposed) and non-occupational (unexposed) volunteers. The samples were wet ashed using conc.  $\text{HNO}_3$  and  $\text{HClO}_4$  to destroy organic matter completely and the residue was dissolved in distilled water. The samples were analysed by ICP - MS using suitable blank and standards [13].

## 2.8. Participation in the IAEA quality control exercises

- a) NAT-3 Air filters intercomparison samples consisting of loaded filter, blank filter and urban dust were analysed for Fe, Ca, Pb, Ti, Zn, Si, Rb and Sr using ED-XRF technique [14].
- b) DEQAS-IAEA intercomparison of Welding fumes loaded filter for Fe, Mn, Ti and Cr(VI) by ED-XRF.
- c) DEQAS-IAEA intercomparison of lyophilised urine samples for Cd and Cr by ICP-MS.

## 3. RESULTS AND DISCUSSION

### 3.1. Monitoring of zinc and cadmium aerosols in a zinc ore processing plant in relation to occupational exposures

#### 3.1.1. Airborne dust concentrations

Table I gives the APM concentration at different operations, it is observed that the dust concentrations in the zinc ore processing plant varied from  $0.13 \text{ mg/m}^3$  to  $49.08 \text{ mg/m}^3$ . The average concentrations at the initial handling stages (grinding and roasting;  $8 \text{ mg/m}^3$ ) is 20 times more than the average dust concentration at the electrolysis stage ( $0.4 \text{ mg/m}^3$ ). Table II provide particle size distribution of airborne dust [15]. At the initial ore processing such as powdering and roasting, nearly 85% of the dust is in the stage corresponding to an effective cut off diameter of  $9 \mu\text{m}$ . Estimation of MMAD taking this fraction also in to account results in very high values for MMAD. However, when this fraction is eliminated the remaining fraction of the airborne dust also indicated a multimodal distribution. The situation changes at

the downstream end (electrolysis) where the airborne dust is distributed in substantially lower sizes and the MMAD works out to about 3  $\mu\text{m}$ . A significant fraction (approx. 10%) of the total dust collected from this process ends up at the backup filter of the Anderson sampler which collects particles of less than 0.4  $\mu\text{m}$ .

Table III provides the data on the analyses of airborne particulate matter in the gross APM collected at the zinc smelter unit. The concentrations showed process specific influence. The concentrations were found to vary from 48.8% to 55.5% (mean = 52%) of the total APM with respect to Zn. The levels were 2 orders of magnitude lower for Cd (0.147–0.155, mean = 0.151).

### 3.1.2. Health Effects of Cd and Zn

OSHA classifies Cd as a human carcinogen. Cadmium has been observed to be mutagenic in mammalian cell culture assay systems. Cd is very bioaccumulative. The primary routes of entry to human body are inhalation and ingestion. Acute exposure to Cd and its compounds are known to cause irritation of the throat and nose, delayed reaction of cough, sweating chills and shortness of breath. In severe cases pulmonary oedema results. Ingestion had been reported to cause nausea, vomiting and abdominal cramps. Chronic over exposure results in lung injury (emphysema) and kidney dysfunction (Proteinurea) and bone lesions [16].

TABLE I: AIRBORNE DUST CONCENTRATIONS IN ZINC SMELTING PLANT

Process	Dust concentrations range ( $\text{mg}/\text{m}^3$ )	Mean ( $\text{mg}/\text{m}^3$ )	No. of samples
Grinding (Ball mill)	1.10 - 1.40	3.98	14
Roasting	0.55 - 49.08	13.94	9
Electrolysis (Cd sponge)	0.13 - 0.55	0.37	12

TABLE II: PARTICLE SIZE ANALYSIS OF AIRBORNE DUST FOR ZINC SMELTING

Process	Percent respirable	Fine fraction <2 $\mu\text{m}$ (%)	MMAD	GSD	Remarks
Ball milling and roasting	8–22	1.0–6.4	—		MMAD very large Distribution multimodal
Electrolysis	67–90 (79)	39.7–59.4 (49.6)	2.2–3.6	3.6–5.0	—

TABLE III: CONCENTRATIONS OF CD AND ZN (PERCENTAGE) IN THE APM IN ZINC SMELTING PROCESS

Process	Zn (%)		Cd (%)		Mean Zn/Cd
	Range	Mean	Range	Mean	
Grinding & roasting	48.4–55.5	52.0	0.147–0.155	0.151	344

For Zn also the primary route of entry is inhalation. Acute over exposure results in metal fume fever symptoms. Excessive skin contact may lead to dermatitis. No symptoms or effects of chronic ever exposure to Zn had been reported [16]. It is not a carcinogen. No data are available on mutagenicity of Zn. Table IV gives the Threshold Limit Values (TLV) for Cd and Zn

### 3.1.3. Elemental Concentrations of Cd and Zn in APM

The airborne concentrations of Cd and Zn exceeded TLV in some of the samples. The Zn/Cd ratio works out to 344. The fraction of the element species below the Mass Median Aerodynamic Diameter (MMAD) of 2  $\mu\text{m}$  accounted for about 4% of the respirable dust at the initial process stages. Respirable APM levels were significantly lower, by a factor of 10, at the down stream process stages (electrolysis), however it was observed that nearly 50% of the airborne particulate species was below 2  $\mu\text{m}$  at the electrolysis process area (Ref table II). However the mean levels of airborne Cd and Zn were below their respective TLVs.

### 3.1.4. Solubilisation (leaching) studies using lung serum simulant [3]

In vitro leaching studies with lung serum simulant and airborne dust in Zn processing has indicated a two components dissolution, the first one being fast which solubilises in about 2h, followed by a slow component which solubilises out at a steady state. Table V summarises the results. Less than 0.1% of Zn leached out in 2 hrs; however nearly 2% of Cd got released during this period. While 0.5% Zn leaches out in 30 days, the leach out Cd is nearly 10 times high. It is evident that a higher percentage of Cd solubilises as compared to Zn. The Zn/Cd ratio in the leachate range from 17.6 to 54.2 (mean = 29.6, SD =  $\pm$  14.9) as against their ratio of 344 in original APM. The enhanced solubilisation of Cd in lung-serum cannot be fully explained on the basis of its chemical nature though CdSO<sub>4</sub> is reported to be more soluble than ZnSO<sub>4</sub> at room temperature. Solubilisation of APM in body fluids is an important parameter determining its uptake and toxicity and therefore this aspect needs more detailed study.

TABLE IV: THRESHOLD LIMIT VALUES (TLV), mg/m<sup>3</sup>, FOR Cd AND Zn [16]

Element	OSHA	ACGIH
Cadmium	0.005 as Cd	0.002 respirable (Cd and its compounds)
Zinc	5 as ZnO fume 10.0 as ZnO dust	5.0 fume 10.0 dust

TABLE V: SOLUBILISATION OF AIRBORNE Zn AND Cd IN LUNG SERUM SIMULANT [3]

Sample	Duration	Quantity leached ( $\mu\text{g}$ )		Zn/Cd
		Zn	Cd	
L1	5 m	18.5	1.5	12.3
L2	30 m	51.1	2.3	22.2
L3	2 h	91.5	2.9	31.6
L4	5 h	102.7	3.2	32.1
L5	24 h	88.0	5.0	17.6
L6	3 d	92.0	2.9	31.7
L7	10 d	103.0	5.3	19.4
L8	30 d	227.5	4.2	54.2

Elemental content in air sample  
Zn - 149.8 mg, Cd - 0.4 mg

Mean = 27.6  
SD =  $\pm$  13.0

### 3.2. Assessment of hazards due to APM in beach mineral separation plants

#### 3.2.1. Size distribution of aerosols at mineral separation plants

Table VI gives the values of MMAD and AMAD with corresponding geometric standard deviations for samples collected from the MSPs and monazite processing plant [17]. MMAD at the Plant I ranged from 2.5 to 8.6  $\mu\text{m}$  with GSD ranging from 2.9 to 5.6. AMAD of the samples varied from 5.5 to 11  $\mu\text{m}$  with GSD varying from 2.6 to 4.4. At Plant II Mass Median Aerodynamic Diameters varied from 2.6 to 12.5  $\mu\text{m}$  with GSD varying from 2.3 to 4.5 whereas AMAD ranged between 2.7 to 15  $\mu\text{m}$  with GSD in the range 3.1 to 4.6. At the initial stages of mineral separation viz. high tension separators the MMAD ranged from 9 to 11  $\mu\text{m}$  and AMAD varied from 5 to 6.6  $\mu\text{m}$ . At the monazite air tables the MMAD and AMAD were higher; above 11  $\mu\text{m}$ . Here the GSD were also higher indicating larger spread in the size distribution. The lowest values were obtained at the general areas away from specific operations. The dust released at the initial stages has a higher MMAD. At the monazite air tables physical resuspension results in higher sizes.

TABLE VI: PARTICLE SIZE DISTRIBUTION OF AIRBORNE DUST IN MINERAL SEPARATION PLANTS [17]

Location	MMAD ( $\mu\text{m}$ )	GSD	AMAD ( $\mu\text{m}$ )	GSD
MINERALS PLANT I				
Ilmenite section	8.6, 5.8	2.9, 3.1	8.5, 11.0	3.0, 2.6
General Areas	5.6	3.5	8.6	2.8
High Tension Separators	2.5, 7.6	5.6, 4.0	7.6, 5.5	4.2, 4.4
MINERALS PLANT II				
Screens and Primary Separators	11, 9.8, 9.1	2.8, 2.6, 2.3	6.6, 5.0, 5.1	3.2, 3.4, 3.1
High Tension Separators	4.9	3.5	2.7	4.2
Magnetic Separators	5.2, 2.6	4.0, 3.2	4.8, 3.2	3.7, 3.1
Monazite Air Tables	12.5	4.5	11.0, 15.0	4.6, 4.2
Average for Minerals Plants	7.1	—	7.3	—
Monazite Plant range	2.9–14.9	3.4–6.5	2.1–9.0	2.9–6.2
(16 samples) mean	$5.3 \pm 2.9$	$4.7 \pm 1.3$	$4.5 \pm 1.9$	$3.5 \pm 0.4$

The general areas show lower sizes for MMAD and AMAD. Since the sizes were not significantly different in the plants an average size of 7  $\mu\text{m}$  AMAD has been assigned for both plants. Earlier studies carried out in the plants indicated substantially higher sizes (only 25% of the dust and air activity were found in the respirable range of  $<11 \mu\text{m}$ ) [5]. The present studies do not show such large sizes. Process related changes, as described earlier, are responsible for significant reduction in the coarse dust.

In the chemical plant processing monazite the MMAD of airborne dust were in the range 2.9 to 14.9  $\mu\text{m}$ , the GSD varying from 3.4 to 6.5. The mean MMAD works out to  $5.3 \pm 2.9 \mu\text{m}$ . The AMAD for the different operations ranged from 2.1 - 9.0  $\mu\text{m}$ , the GSD varying from 2.9 to 6.2. The mean AMAD works out to  $4.5 \pm 1.9 \mu\text{m}$ .

### 3.2.2. Health effects of Th and Ce

Monazite is the principal ore of thorium and the rare earth elements. Monazite contains the naturally occurring thorium chain nuclides in radioactive equilibrium. Inhalation is the most important route of occupational exposure to Th and Ce. The health effects due to Th are dependent on the committed effective dose received from the intake of Th and its radioactive daughter products. Experimental and epidemiologic data suggest that inhalation exposure to high concentration of stable rare earths can produce lesions compatible with pneumoconiosis and progressive pulmonary fibrosis. Due to the paucity of information available no exposure limits have been set for inhalation of stable rare earth elements including Ce [18]. However for cerium dioxide a short-term exposure limit of 5.0 mg /m<sup>3</sup> is reported [19]. Inhalation dose due to Th is mainly contributed by <sup>228</sup>Th and <sup>232</sup>Th. Oxides and hydroxides of Th and Ce are assigned to inhalation class Y (type S as per the new lung model). Since Th in monazite is a constituent of the mineral itself and is highly resistant to leaching it is considered as S type.

Using the ICRP dose conversion factors the ALI applicable for the mineral separation plants is estimated as follows [20].

$$\text{ALI } (^{228}\text{Th}) = \frac{0.02 \text{ Sv}}{3.9 \times 10^{-5} \text{ Sv/ Bq}} \quad (\text{for } 1\mu\text{m AMAD, S type})$$

$$\text{ALI } (^{232}\text{Th}) = \frac{0.02 \text{ Sv}}{2.3 \times 10^{-5} \text{ Sv /Bq}} \quad (\text{for } 1\mu\text{m AMAD, S type})$$

The individual ALIs work out to 513 Bq and 870 Bq for  $^{228}\text{Th}$  and  $^{232}\text{Th}$ , respectively. Since monazite contain  $^{228}\text{Th}$  and  $^{232}\text{Th}$  in equilibrium and the presence of one nuclide implies the presence of the other also, a combined ALI is worked out as follows.

$$\text{ALI (total)} = \frac{\text{ALI } (^{228}\text{Th}) \times \text{ALI } (^{232}\text{Th})}{\text{ALI } (^{228}\text{Th}) + \text{ALI } (^{232}\text{Th})}$$

The combined ALI works out to 322 Bq for 1  $\mu\text{m}$  AMAD and Type S particulates. For 7  $\mu\text{m}$  AMAD the individual ALI works out to 783 Bq and 1675 Bq, for  $^{228}\text{Th}$  and  $^{232}\text{Th}$  respectively with a combined ALI of 534 Bq. The resultant DAC is,

$$\text{DAC} = \frac{\text{ALI (Bq)}}{2400 \text{ m}^3} = \frac{534 \text{ Bq}}{2400\text{m}^3} = 0.22 \text{ Bq/m}^3$$

applicable to the mineral separation plants.

The combined ALI for the monazite processing plant works out to 385 Bq. The corresponding DAC is 0.16 Bq/m<sup>3</sup> [21].

### 3.2.3. Concentrations of Th and Ce in Mineral Separation Plants

Tables VII and VIII gives the airborne concentrations of Th and Ce in the two MSPs. The air activity due to Th in these plants varied from 0.001 to 0.066 Bq/m<sup>3</sup> and was well below the DAC of 0.22 Bq/m<sup>3</sup> applicable to the MSPs under study. The average air activity levels encountered in these plants indicate individual radiation exposures in the range of 1.0 to 2.0 mSv per annum due to airborne Th. The International Commission for Radiation Protection (ICRP) stipulates 20 mSv as the annual limit of occupational radiation exposure [22]. The Ce concentrations were in the range 0.78 to 52.71  $\mu\text{g} /\text{m}^3$ . These levels are much lower than the short-term exposure limits stipulated for cerium oxide.

TABLE VII: AIRBORNE CONCENTRATIONS OF  $^{232}\text{Th}$  AND Ce IN MINERAL SEPARATION PLANT I

Location /Process	$^{232}\text{Th}$ air activity ( $\text{Bq}/\text{m}^3 \times 10^{-2}$ )		Airborne Ce ( $\mu\text{g}/\text{m}^3$ )	
	Range	Mean	Range	Mean
Sand screening/storage	0.1–2.9	1.2	0.78–22.73	9.39
Ilmenite section	0.1–5.9	2.3	0.78–46.25	18.04
High tension separators	0.2–3.4	1.6	1.56–26.65	12.53
Zircon section	0.6–4.0	2.4	4.70–31.35	18.81
Rutile section	1.0–2.2	1.6	7.83–17.25	12.53
Leucoxene section	0.9–4.0	2.0	7.05–31.35	15.69
Zircon grinding	0.1–0.5	0.4	0.78–3.91	3.13
General areas	0.2–4.0	1.3	1.56–31.35	10.18

Derived Air Concentration (DAC)  $^{232}\text{Th} = 0.22 \text{ Bq}/\text{m}^3$   
 Number of samples collected and analysed = 120

#### 3.2.4. Airborne Dust Concentrations in Mineral Separation Plants

Table IX gives a summary of the dust concentrations encountered in the work atmosphere of the MSPs. An average MMAD of  $7.1 \mu\text{m}$  estimated for these plants will result in a pulmonary deposition of 9% for the airborne dust. Total deposition depends on the concentrations, pulmonary deposition fraction and the breathing rate. From the particle size characterization data it was observed that respirable part of the dust constituted 41% to 88% (mean = 57%) of the total airborne dust [2]. Accordingly the average respirable dust concentrations measured for MSP I and MSP II are  $0.69 \text{ mg}/\text{m}^3$  and  $0.82 \text{ mg}/\text{m}^3$  respectively. The content of free silica in the airborne dust encountered in the MSPs amount to 15%. The corresponding TLV for respirable dust works out to  $1 \text{ mg}/\text{m}^3$ . The average levels of respirable dust in these plants were below TLV. However there were occasions when transient levels of dust concentrations above TLV were observed.

TABLE VIII: AIRBORNE CONCENTRATIONS OF  $^{232}\text{Th}$  AND Ce IN MINERAL SEPARATION PLANT II

Location /Process	$^{232}\text{Th}$ Air activity ( $\text{Bq}/\text{m}^3 \times 10^{-2}$ )		Airborne Ce ( $\mu\text{g}/\text{m}^3$ )	
	Range	Mean	Range	Mean
Sand screening/	0.6–2.4	1.3	4.70–18.82	10.18
High tension separators	0.8–3.9	2.1	6.26–30.56	16.47
Magnetic separators	0.8–6.6	3.9	6.26–51.71	30.56
Monazite air tables	0.8–5.8	3.5	6.26–45.47	27.43
Monazite bagging/container filling	1.3–1.8	1.5	10.18–14.10	11.74
Ilmenite section	1.1–1.8	1.6	8.61–14.10	12.53
Zircon section	0.4–1.9	0.9	3.13–14.91	7.05
Garnet section	0.4–1.8	0.8	3.13–14.10	6.26
Rutile section	0.6–2.0	1.5	4.70–15.69	11.74

Derived Air Concentration (DAC),  $^{232}\text{Th} = 0.22 \text{ Bq}/\text{m}^3$   
 Number of samples collected and analysed = 180

TABLE IX: AIRBORNE DUST CONCENTRATIONS IN MINERAL SEPARATION PLANTS

Location /Process	MSP-I Dust concentration ( $\text{mg}/\text{m}^3$ )		MSP-II Dust concentration ( $\text{mg}/\text{m}^3$ )	
	Range	Mean	Range	Mean
Sand screening/storage	0.10–2.10	0.76	0.13–3.86	1.85
High tension separators	0.12–3.33	0.96	0.80–3.03	1.60
Magnetic Separators	—	—	0.33–2.80	1.21
Monazite air tables	0.60–1.10	0.86	0.20–2.53	0.71
Ilmenite section	0.27–7.51	1.45	0.40–2.67	1.71
Zircon section	1.13–2.53	1.01	0.20–1.87	1.40
Garnet section	—	—	0.50–2.06	1.28
Rutile section	0.50–4.67	1.90	0.86–3.86	1.80
Leucoxene section	0.31–4.60	1.85	—	—
General areas	0.30–2.60	1.00	—	—
Average		1.22		1.45

Total number of samples collected and analysed = 300  
 Respirable fraction = 0.57  
 TLV for respirable dust =  $1.0 \text{ mg}/\text{m}^3$

### 3.3. Thorium in urine and thoron ( $^{220}\text{Rn}$ ) in exhaled breath as indicators of internal exposures in monazite and thorium processing

Table X gives the results of Urine analysis for Th and TIBM carried out for the three groups studied. The occupational workers selected were in the age group 35-55 years with exposure history ranging from 5 to 25 years (chronic). The concentration of thoron in the exhaled breath averaged  $7 \text{ mBq}/\text{L}$  for subjects from the mineral separation process. The mean



concentration of Th in the urine samples for this group is 295 ng/L. The corresponding data for monazite processing is 8 mBq/L for thoron in breath and 397 ng/L for Th in urine. The mean duration of exposure was 18 years for the first category and 10 years for the second. Obviously, there is no one to one correlation between thoron in breath and urine data. The mean urinary concentrations of the two groups show a larger difference than the thoron breath concentrations. This is expected as the nature of APM differs in both the operations. In the first instance (MSP), the inhaled mineral dust tends to remain in the lung for a longer period of time as it is insoluble. This will contribute to a higher lung burden. In the second instance (MCP) the inhaled particulates have a higher solubility in the lung fluids and tend to get translocated from the initial site of deposition (lung) at a faster rate. This will give rise to a reduced lung burden, however enhanced levels in the urine will result. It is observed that the background contribution to thorium in urine (65 ng /L) and thoron in breath (1.8 mBq/L) are significant in NHBRA. This aspect needs consideration whenever occupational exposures in mineral separation plants are discussed, most of these plants being located at the NHBRA.

The mean values of the airborne Th encountered at the plants under study for the past 15 years were considered for estimating the occupational inhalation exposures. The urinary excretion was estimated for AMAD of aerosols normally encountered in these plants. For estimating the inhalation exposures at NHBRA, the intakes were calculated for the air activity (Th) for 1  $\mu\text{m}$  AMAD as the default value for the aerosols [23]. In the case of occupational workers the average period of exposure and in the case of NHBRA the average age was used for estimating the urinary excretions. The urinary excretion rates were estimated from the ICRP model for inhaled Th [24, 25].

Table XI compares the observed and estimated urinary excretion rates for the three groups studied. It is seen that the estimated and measured values are in fairly good agreement with the metabolic model with respect to MCP workers. Discrepancies were observed for the other two groups. The lower urinary excretion rates for mineral dust inhalation as observed here is due to the extreme chemical resistance of the inhaled dust and has already been reported [2]. In the NHBRA the discrepancy is still larger and is due to the different modes of intake to which the population is subjected to. People residing at the NHBRA are known to have higher uptake of Th through air, water and food [23, 26].

TABLE X: THORIUM IN URINE AND THORON-IN-BREATH

Subject Group	Age Group (Y)	Period of exposure (Y)	Th in Urine (ng/L)	Thoron in breath (mBq/L)
MSP (15 subjects)	35–55	10–25 (18.7 ± 2.8)	150502 (295 ± 104)	3.0–13.0 (7.0 ± 2.3)
MCP (12 subjects)	35–55	5–17 (10.0 ± 3.0)	143–587 (397 ± 157)	4.0–14.6 (8.0 ± 2.8)
NHBRA (15 subjects)	30–54	—	43–81 (65 ± 12)	0.4–2.7 (1.8 ± 0.6)

MSP – Mineral Separation Plant, MCP - Monazite Chemical Plant

NHBRA – Natural High Background Radiation Area

Figures in parentheses give mean ± SD.

TABLE XI: ESTIMATED AND OBSERVED URINARY EXCRETION OF THORIUM

Subject group	Th excretion rate, ng/d		Observed/Estimated
	Observed	Estimated	
NHBRA	91 ± 16.8	20.6	4.42
MSP	413 ± 145.6	3723.8	0.11
MCP	555.8 ± 219.8	754.8	0.73

### 3.4. Thorium and cerium in blood

The results of a limited number of blood samples collected from monazite plant workers and analysed for Th and Ce by ICP-MS are presented in table XII. The results are preliminary in nature and wide variations are observed in the individual Th and Ce concentrations. Further work is needed to arrive at any meaningful conclusions from the blood analysis results. The background contributions of these elements can be significant and need to be investigated.

TABLE XII: CONCENTRATIONS OF Th AND Ce IN BLOOD - MONAZITE PLANT WORKERS

	Ce (ng/ml)	Th (ng/ml)	Ce/Th
Range	2.5–502.5	7.5–90.0	0.43–17.75
Mean	77.3	19.2	4.3 ± 4.7

Note : Number of samples = 15

#### 4. CONCLUSIONS

Monitoring of aerosols released during the processing of zinc ore have shown that 85% of the airborne dust released are above 9  $\mu\text{m}$  MMAD at the initial stages. However the MMAD at the down stream processing was about 3  $\mu\text{m}$ . The elemental concentrations and their ratios in the raw material were reflected in the APM at the initial stages. Detailed size characterization studies showed that up to 50% of APM was below 2  $\mu\text{m}$  in some process areas. Elemental concentrations of Cd and Zn exceeded the ACGIH recommended TLVs at some of the locations. Studies on the solubilisation of APM in lung serum simulant demonstrated fast and slow components for both Cd and Zn. Cadmium showed preferential solubilisation, nearly ten times higher than that for zinc for 30 days leaching. This implies that from the respirable dust deposited in the pulmonary region of the lungs Cd will get preferentially transported to other sites.

The introduction of dredge mining and wet concentration process have resulted in substantial reduction in the sizes of airborne particulates in the MSPs. The average respirable dust concentrations in the plant were lower than the TLV. The particle size distribution of aerosols in the mineral separation plants shows average AMAD of 7  $\mu\text{m}$  (range 2.7–15.0  $\mu\text{m}$ ; GSD 2.6–4.6). ALI and DAC derived for  $^{232}\text{Th} + ^{228}\text{Th}$  are 534 Bq and 0.22 Bq/m<sup>3</sup> respectively, on the basis of ICRP dose conversion factors and considering secular equilibrium in monazite. The prevailing air activity levels (Th) in the plants indicate per capita yearly internal exposures in the range of 1.0 to 2.0 mSv. For the plants processing monazite the ALI and DAC derived for  $^{232}\text{Th} + ^{228}\text{Th}$  are 385 Bq and 0.16 Bq/m<sup>3</sup> respectively.

The studies show that in the case of inhalation exposure to airborne radioactive mineral dust and thorium the differences in the physico-chemical form of the intake, the subsequent translocation from the lungs and the natural environmental contribution (particularly at NHBRA) are important parameters to be considered while applying metabolic models and interpreting the urine analysis or breath thoron results for internal dose evaluation. Inhaled mineral dust tend to remain in the lungs for longer periods of time as it is insoluble, contributing to higher lung burden and lower urinary thorium concentrations in the case of beach Mineral sand Separation Plant workers. In the case of workers engaged in chemical processing of monazite the inhaled particulates have a higher solubility and results in faster elimination from the lungs (reduced lung burden) and enhanced urinary Th concentrations.

#### REFERENCES

- [1] SCHALLER, K.H., Selected Metals: Cadmium: in Biological Monitoring of Chemical Exposure in the Work Place, Guidelines, World Health Organisation, Geneva (1996) 52–73.
- [2] INTERNATIONAL ATOMIC ENERGY AGENCY, CRP-IND-9476, First Progress Report, First RCM, IAEA, Vienna (1997).
- [3] INTERNATIONAL ATOMIC ENERGY AGENCY, CRP-IND-9476, Second Progress Report, Second RCM, Belo Horizonte, Brazil (1999).
- [4] INTERNATIONAL COMMISSION ON RADIOLOGICAL PROTECTION, Human Respiratory Tract Model for Radiological Protection, Publication 66, Ann. ICRP **24**(1/4) (1994).

- [5] PILLAI, P.M.B., et al., Particle size distribution of airborne dust and derived air concentration for Thorium in the beach mineral processing in India, *Bull. Rad. Protection* **18**(1&2) 188–191 (1995).
- [6] PAUL, A.C., Occupational Exposure in the Beach Mineral and Monazite processing in Kerala and Tamil Nadu, Tech. Meeting, Nov.1997, Health Physics Division, BARC, Mumbai (1997).
- [7] HEWSON, G.S., FARDY, J.J., Thorium metabolism and Bioassay of Mineral sand workers, *Health Physics* **64** (1993) 147–156.
- [8] SUJATA, R., et al., Urinalysis as an indicator for exposure due to inhalation of Th bearing dust, *Bull. Radiat. Prot.* **18**(1&2) (1995) 185–187.
- [9] LIPZTEIN, J.L., Bioassay Monitoring studies for Thorium, *Radiat. Prot. Dosim.* **26** (1989) 57–60.
- [10] KANAPILLI, G.N., et al., Measurement of In vitro Dissolution of Aerosol Particles for comparison to In-vivo Dissolution in the Lower Respiratory Tract after Inhalation, *Health Physics* **24** (1973) 495–507.
- [11] MAYYA, Y.S., et al., Measurement of Thoron in the Exhaled Breath of Thorium plant workers, *Health Physics* **51**(6) (1986) 737–744.
- [12] JAISWAL, D.D., et al., Bioassay Monitoring for Thorium — a sensitive method, *Bull. Radiat. Prot.* **14**(3 &4) (1991).
- [13] MAHALINGAM, T.R., et al., Studies on some Trace and Minor elements in Blood, *Biological Trace Element Research* **57** (1997) 191–206.
- [14] BLEISE, A., SMODIŠ, B., Report on the Inter comparison Run Nat-3 for the Determination of Trace and Minor Elements in Urban Dust Artificially Loaded on Air Filters, International Atomic Energy Agency, NAHRES-43, Vienna (1999).
- [15] PILLAI, P.M.B., et al., Monitoring of Zn and Cd aerosols in a Zinc Ore Processing Plant in Relation to Occupational Exposures, Proc. of the Conference on aerosol behaviour in confined environments, February 2000, Mumbai, IASTA Bulletin, Special Issue **13**(1) (2000).
- [16] MSDS, Canadian Centre for Occupational Health and safety, Issue: 99-3 (1999).
- [17] HARIDASAN, P.P., et al., Assessment of AMAD and MMAD for Airborne Particulate matter in the Beach Mineral separation Plants — Modification of ALI and DAC, Proc., 24<sup>th</sup> IARP Conf. Kakrapar (1999).
- [18] HALEY, P.J., Pulmonary toxicity of Stable and Radioactive Lanthanides, *Health Physics* **61**(6) (1991).
- [19] INTERNATIONAL LABOUR ORGANIZATION, Occupational Exposure Limits for Airborne Toxic Substances, Third Edition (1991).
- [20] INTERNATIONAL ATOMIC ENERGY AGENCY, Safety Standards, IAEA Safety Series 115 (1996).
- [21] HARIDASAN, P.P., et al., Derived Surface Contamination Limits for the Chemical Processing of Monazite, *Radiation Protection and Environment* **24**(1&2) (2001) 219–221.
- [22] INTERNATIONAL COMMISSION ON RADIOLOGICAL PROTECTION, 1990 Recommendations of the International Commission on Radiological Protection, ICRP Publication 60, *Annals of the ICRP* **21**(1-3) (1991).
- [23] PAUL, A.C., et al., Population exposure to airborne thorium at the high natural radiation areas in India, *J. Environ. Radioactivity* **40**(3) (1998) 251–259.
- [24] PILLAI, P.M.B., et al., Thorium in Urine and Thoron in Exhaled Breath as indicators of Internal Exposures in Monazite and Thorium Processing, *Radiation Protection and Environment* **24**(1&2) (2001) 105–108.

- [25] UNNIKRISHNAN, et al., Organ Burdens and Elimination Rates for inhaled Th and Pu, BARC Report No.1312 (1986).
- [26] PAUL, A.C., et al., Pathways of internal exposure at the High Background Area, Proc. International Conference on High Levels of Natural Radiation, Ramsur, Iran (1990).

# THE USE OF NUCLEAR AND RELATED TECHNIQUES FOR THE STUDIES OF POSSIBLE HEALTH IMPACT OF AIRBORNE PARTICULATE MATTER IN A METAL INDUSTRY

B. WIDJAJAKUSUMA<sup>1</sup>, H. DJOJOSUBROTO<sup>2</sup>, A. HIDAAYAT<sup>2</sup>, D. SUPRIATNA<sup>2</sup>, E. KUMOLOWATI<sup>2</sup>

<sup>1</sup> Department of Internal Medicine, Medical Faculty, University of Padjadjaran, Indonesia

<sup>2</sup> Center for Research and Development of Nuclear Techniques, National Nuclear Energy Agency, Bandung, Indonesia

## Abstract

Possible health effects of airborne particulate matter in the workplace were investigated by searching the correlation between the enriched elements in the airborne particulate matter and elemental levels of blood, nail and hair of workers in a metal industry. Blood, hair and nail samples were collected from 58 workers of a metal industry, and airborne particulate matter (APM) samples were collected from halls or buildings where the workers were carrying out their work. The workers were subjected to medical examination comprising medical history recording, physical examination and routine blood check. The collected biological and APM samples were analysed for trace elements by neutron activation analysis. A general tendency of higher zinc levels in serum and erythrocytes in workers than in healthy individuals (controls) was observed. However, more examinations on a larger population need to be carried out in order to confirm this finding on a statistically sound basis.

## 1. INTRODUCTION

During the last twenty five years industrialization in Indonesia has strongly supported national economic development, and hence improves the quality of life of the Indonesian people. The industrial and economic developments, however, are also accompanied by side effects. Various processes in an industry may lead to the formation of gases and fine airborne particulate matter (APM). Emission of these matters to open atmosphere may cause degradation of environmental quality. Elements in the fine particulate matter may enter human body through inhalation and direct contact with skin. Those elements will be accumulated in the organs, namely liver, kidneys and brain, manifest in clinical syndromes such as hypertension, renal failure and neurological symptoms and signs. The elements are excreted through urinary tract in urine. They can also be excreted through hair and nails. Elevated blood and urinary aluminium levels have been observed after occupational exposure to different aluminum compounds. This phenomenon indicates the absorption through inhalation, as there are no data indicating significant dermal absorption for aluminum [1]. The aluminum compounds vary greatly in their toxic and carcinogenic effects. Absorption of chromium compounds in the workplace occurs mainly through inhalation. It seems that metallic chromium does not have harmful effect to human health [2]. The absorption is dependent on the valence and solubility of the particular chromium species. Some elements such as trivalent chromium ions are readily cleared from the blood, but hexavalent chromium is retained much longer in the blood. Although the trivalent chromium is readily excreted, continuous chromium intake may cause the blood chromium level higher than normal.

Several elements can either have deleterious effects on or considered essential for human health. Selenium for example, is considered essential, as depletion results in a deficiency syndrome and repletion reverses the abnormality. It was observed for example serum

selenium level of female acute myocardial infarction is significantly lower than that of normal person. From these observations it was shown that the probability of getting myocardial infarction for selenium deficient female was five times higher than that of normal person [3]. Although some elements are considered essential, if present at levels exceeding the limit of safe exposure, they are potentially toxic and therefore hazardous to human health. Microgram amount of selenium in food (40–100 µg/kg of food) is essential, but at higher levels (greater than 1 mg/kg of food) selenium is toxic [4]. Consequently higher level of certain elements in human tissues (such as blood, hair and nail) than the normal level may indicate intoxication that has deleterious effects on human health.

The present study deals with the possible health effects of airborne particulate matter in the workplace by searching the correlation between the enriched elements in the APM and elemental levels of blood, nail and hair of workers in a metal industry. Subsequently these parameters will be correlated with the health conditions of the workers.

The airborne particulate samples are collected at the workplace during the working hours. The elemental levels in blood, nail and hair of the workers are compared to those of control which consist of healthy individuals from different places. Their health conditions are examined by medical examination and biochemical analysis of their blood. The correlation among various parameters is determined by statistical analysis.

## 2. METHODS

Blood, hair and nail samples are collected from 58 workers of a metal industry in Bandung (about 180 km south east Jakarta). The age of the workers is between 25–52 years, and most of them have worked for more than 5 years. They work in several sections, namely smelter, electroplating, heat treatment and painting. In this study they are subject to medical examination, which consist of

- Medical history: including family history; symptoms of skin diseases; cardiovascular disorder: palpitation, chest pain, fainting sensation; lung disorder: shortness of breath, chronic cough; neurological symptom such as paresthesia, muscle pain, muscle cramp, seizures, twitching or convulsion; gastrointestinal disturbances: nausea, vomiting; hypertension and infertility. Smoking habits (common or clove cigarettes, total of cigarettes consumed daily), constituents of daily meals and the use copper or aluminum equipment for cooking or boiling water; any diseases or abnormalities observed by the individuals during his working period in the section.
- Physical examination: routine complete check, -resting electrocardiograph: 12 lead ECG.
- Routine blood check: hematology: hemoglobin; white blood cells; erythrocyte sedimentation rate; packed cell volume; kidney function test: blood urea-N; liver function tests: serum glutamic oxalo-acetate transaminase (SGOT), serum glutamic pyruvate transaminase (SGPT); lipid profile: total cholesterol, high density lipoprotein (HDL) cholesterol, low density lipoprotein (LDL) cholesterol and triglyceride; uric acid.

The preparation of blood sample was performed as follows. The blood was drawn following an overnight fast before breakfast, by means of I. V. catheter Becton-Dickenson USA from cubiti vein with a slight pressure to prevent from hemolysis. Three fractions consist of respectively 10 cm<sup>3</sup> blood will freely flow into 3 pre cleaned polyethylene tubes (Sarstedt Germany). The cleaning of the polyethylene tube involving soaking the tube for 3 days in a 15:10:75 (v:v:v) mixture of 65% Suprapur nitric acid, 96% Suprapur sulphuric acid and quartz-bidistilled water, followed by rinsing with quartz-bidistilled water and drying the tubes in clean room (room 100). These tubes are stored in a polyethylene bag until being used [5].

The blood samples in the first tubes were sent to clinical laboratory for biochemical examination. Those in the second and third tubes, which are considered free from metal contamination by the needle of the catheter, are used for trace element study. To minimize contamination by dust particulates during sample preparation, the following steps were performed in a clean room (class 100). Sera in the polyethylene tubes were separated from erythrocyte by centrifugation twice at 3000 rpm for 20 minutes. In this respect the metal part of the centrifuge is coated with polystyrene. To avoid fractionation during cooling, sera and erythrocyte fraction were then frozen by dipping in liquid nitrogen, and be kept in frozen condition in a freezer at -40°C. The sera and erythrocyte in the polyethylene tubes were dried using freeze drying equipment (Christ Loc-1).

Approximately 1 g of toe nail and hair samples were taken respectively from every worker. The nail was cut using commercially available stainless steel nail cutter. The hair samples were taken from hair on the back of the head close to the nape. About 2 cm of hair were cut as close to the scalp as possible. To eliminate grease and surface contamination the hair samples were rinse with acetone [6]. The nail samples are washed in 1% solution of TRITON X-100 in de-ionized water in an ultrasonic bath [7]. Toe nails and hair were stored in small plastic tubes.

APM samples are collected from halls or buildings where the workers carry out their work. The sample collection was carried out during working hours (from 9 a.m. to 4 p.m.). The APM was deposited on pre-weighed Nuclepore filters using Gent sampler. The sampling head of the Gent sampler, which was placed 1.6 m above ground level [8], separated the particulate matter into two fractions, i.e. coarse (aerodynamic diameter 2.5–10 µm) and fine (< 2.5 µm) fractions. Prior to weighing until constant weight, the filter was equilibrated in a preconditioned chamber at 25°C, 50% relative humidity. The amount of deposited APM on the filter was determined by weight difference of the filter before and after sample collection.

Elemental concentrations in the APM samples were determined by instrumental neutron activation analysis (INAA). Short lived induced radioactivity measurement was performed by irradiation the samples in a neutron flux of 10<sup>14</sup> n cm<sup>-2</sup> s<sup>-1</sup> for 20–30 seconds, and promptly counting the irradiated samples on a gamma-ray spectrometer. The quantification of elements that produced long lived induced radioactivity were accomplished by irradiation the samples in a neutron flux of 10<sup>14</sup> n cm<sup>-2</sup> s<sup>-1</sup> for 30 minutes, and following 2–3 week cooling. These samples were counted using a high resolution gamma-ray spectrometer. The neutron irradiation was performed in a multipurpose reactor (in Serpong). Spectral resolution of the spectrometer systems used in this experiment were 1.9 keV (FWHM) for 1332.4 keV line emitted by <sup>60</sup>Co and the peak to Compton ratio was better than 35. Elemental (e.g. zinc and selenium) levels in sera and erythrocyt samples were determined by exposing 0.2 g of the lyophilized samples in a neutron flux of ~10<sup>14</sup> n cm<sup>-2</sup> s<sup>-1</sup> for two hours. The gamma-ray spectra are counted following 2–3 weeks cooling time.



### 3. RESULTS

Fifty eight workers had completed their medical check up blood test and ECG tracing. On physical examinations it was observed that: 34 workers had no abnormality; 2 hypertension (high blood pressure): 1 without abnormality in ECG, 1 had left ventricular hypertrophy & myocardial ischemia; 7 hypotension (low blood pressure) with normal ECG; 2 hypotension with suspected myocardial ischemia; 1 emphyzema; 1 glaucoma (high eyeball pressure). ECG tracing showed that: 4 suspected of myocardial ischemia or cardiomyopathia; 5 nonspecific S-T elevations with unknown cause (may be due to previous pericarditis or myocarditis - this matter need further investigation to confirm our assumption); 1 bradycardia, 1 atrial fibrillation with normal ventricular response.

Biological data that were obtained from biochemical analysis is presented in Table I. This Table shows that: 1 had hemoglobin content more than 18 gr % and 1 with packed cell volume more than normal (1.7%); red blood cells, kidney function tests and uric acid levels were normal. Ten had SCOT elevation and 11 with SGPT elevation contribute to 17.3% and 19.1% respectively. Lipid profile: 7 had high total cholesterol level with 3 elevated HDL cholesterol less than normal and 8 LDL cholesterol higher than normal, represent respectively 12.1%, 5.1% and 14.1%. Six had triglyceride level higher than 200 mg % (10.4%).

TABLE I: BIOCHEMICAL DATA OF WORKERS OF A METAL INDUSTRY

	Normal Value	Abnormal	Percentage (%)
Hematology:			
Hemoglobin	13.5–18.9 g %	1	1.7
Erythrocytes	(4–5.5) x 10 <sup>6</sup> /c mL	0	0
Packed Cell Volume	40–54%	1	1.7
Kidney Function:			
Urea-N	< 30 mg %	0	0
Uric Acid	< 7 mg %	0	0
Liver Function:			
SGOT	< 25 IU/L	10	17.3
SGPT	< 25 IU/L	11	19.1
Lipid Profile:			
Total Cholesterol	< 220 mg %	7	12.1
HDL Cholesterol	> 35 mg %	3	5.1
LDL Cholesterol	< 150 mg %	8	14.1
Triglyceride	< 200 mg %	6	10.4

The levels of APM in the workplace are summarized in Table II. The concentration of the fine fraction APM was from ~25 µg/m<sup>3</sup> (painting department) to 130 µg/m<sup>3</sup> (sandblasting department). The average levels of fine fraction in these places, except in sandblasting department are about the same as the APM in an urban area (Bandung area). The coarse levels, however, are significantly higher than those in urban areas.

TABLE II: LEVELS OF APM IN THE WORKPLACE,  $\mu\text{g}/\text{m}^3$ 

	Average Coarse Level	Range	Average Fine Level	Range
Smelter I	340	110–600	40	10–120
Smelter II	170	130–220	30	10–50
Survey Heat Transfer	40	20–90	30	10–40
Painting	70	30–220	25	10–50
Sandblasting	2000	300–2900	50	10–130

Neutron activation analysis results for APM were validated by analyzing reference materials: pond sediment for Al (found:  $104 \pm 7$  mg/g, certified value:  $106 \pm 5$  mg/g), and Zn (found  $331$  mg/g certified value  $343 \pm 17$  mg/g); and coal CR No 40 for Zn (found  $37 \pm 6$  mg/kg, certified value  $30.2 \pm 1.9$  mg/kg).

Content of 12 elements were determined by instrumental neutron activation analysis, namely Al, Na, V, Mn, Br, Cl, Cr, Fe, Zn, Sb, Sc, and Ce. These elements are common elements in the APM. However, several elements that are released by the metal industry will be enriched in the aerosols. Neutron activation analysis of the APM collected in late 1997 (October, November, December) showed that the samples from metal industry was enriched by zinc and chromium. The range of the enrichment factor (reference element was scandium) for zinc in the fine fraction was 5 (from smelter department) to 30 (painting department), but mostly about 10. No significant enrichment for chromium was observed in the fine fraction. In coarse fraction, the lowest enrichment factors for chromium and zinc respectively were 3 and 16 (all from smelter department), and the highest were 159 for chromium and 95 for zinc (all from heat treatment department). The enrichment factor for chromium and zinc in APM collected in late 1998 were lower, i.e. up to 10 for both Cr and Zn in fine fractions. In coarse fractions no enrichment was observed for Cr and Zn, except in sandblasting department (about 100). Although the enrichment factors were only 5–7 in fine fractions and 7–8 in coarse fractions, it is considered that Al is significantly enriched in the APM samples. This is due to Al abundance in the nature (comprising approximately 8% in earth crust) [1].

Based on the fact that the airborne particulate matter is enriched by Cr, Zn and Al, we focused ourselves on the analysis of these elements in the tissue samples. However, due to technical difficulty up to the present we were not able to analyze all samples. Therefore, what is presented in this report is only part of the data we expect. Selenium and zinc levels in human sera and erythrocyte are presented in Table III.

TABLE III: ZINC AND SELENIUM LEVELS IN HUMAN SERA AND ERYTHROCYTES

		Normal Value	Worker	Control	Note
Zn	Serum	$0.958 \pm 0.088 \mu\text{g/mL}$	$2.4 \pm 3.3 \mu\text{g/mL}$	$0.46 \pm 0.16 \mu\text{g/mL}$	S
	Erythrocyte	$42 \pm 6 \mu\text{g/g}$	$80 \pm 115 \mu\text{g/g}$	$17.1 \pm 4.5 \mu\text{g/g}$	S
Se	Serum	$0.0543 \pm 0.0113 \mu\text{g/mL}$	$0.07 \pm 0.02 \mu\text{g/mL}$	$0.07 \pm 0.03 \mu\text{g/mL}$	NS
	Erythrocyte	$0.120 \pm 0.400 \mu\text{g/g}$	$0.6 \pm 0.3 \mu\text{g/g}$	$0.5 \pm 0.1 \mu\text{g/g}$	NS

Note: S = significantly different; NS = not significant

#### 4. DISCUSSION

Serum zinc concentration is 16% higher than in the plasma [9]. Higher zinc in serum has been attributed to the liberation of zinc from the platelets during the process of clotting and to invisible hemolysis of red cells, which occurred regularly. Plasma zinc concentration in normal subjects is  $112 \pm 12 \mu\text{g/g}$  [10], and serum zinc level:  $1.299 \pm 0.139 \mu\text{g/mL}$ , whereas using RNAA method  $0.958 \pm 0.088 \mu\text{g/mL}$ . Zinc values in the red cells have been reported in the literature from 10–14  $\mu\text{g/mL}$  of red cells [11]. Value obtained from [10] is  $42 \pm 6 \mu\text{g/g}$  hemoglobin.

There are 3 types of toxic reactions to zinc that have been reported. The first, the metal fume fever, characterized by pulmonary manifestations, fever, chills and gastroenteritis, has been observed to occur in industrial workers who are exposed to the fumes [12]. In the second type, toxicity is characterized by drowsiness, lethargy and increased serum lipase and amylase levels which means impaired pancreatic functions. These symptoms appear if 12 g of zinc sulphate is ingested [13]. The third type is really acute poisoning which might happen in patients following hemodialysis. The contaminated water from galvanized tank was accidentally used for hemodialysis. Death was reported to the person who ingested 45 gm of zinc sulfate [14]. Health effect to the workers exposed to zinc oxide fumes on the job, called metal fume fever, a general term applied to disorders associated with breathing fumes of metal heated above their melting points. The symptoms include rapid breathing, shivering, fever, sweating, chest and leg pain, and weakness. Zinc chloride is the primary cause of lung damage and death.

The recommended daily allowance (RDA) for zinc element is 15–30 mg daily. But 2 g zinc sulfate had been used to induce vomiting, as emetics in old days [15]. The toxic dose for zinc is very high compared to RDA and in food content. Acute poisoning can only happen accidentally or in suicide cases. In humans zinc is transported through intestinal lumen or bronchiolus which has barrier to balance the absorption of minerals. Vomiting is one of the protective mechanisms of the body to eliminate zinc excess.

Occupational safety and health act (OSHA) recommended the safety of air zinc content at working places for zinc chloride fume:  $1 \text{ mg/m}^3$  and zinc oxide  $5 \text{ mg/m}^3$ . In our study airborne zinc concentration at the work place was  $0.5 \mu\text{g/m}^3$ , which was below EPA (Environmental Protection Agency) and OSHA safety recommendations. Serum zinc concentrations of workers and controls were  $2.372 \pm 3.343 \mu\text{g/mL}$  and  $0.464 \pm 0.164 \mu\text{g/mL}$  respectively, which is statistically significant. Zinc concentration in erythrocytes among workers was  $80 \pm 15 \mu\text{g/g}$  and among controls  $17.7 \pm 4.5 \mu\text{g/g}$ , which was statistically significant.

On physical examination, none of the workers had symptoms which might be related to the zinc excess/toxicity. Although some of the workers had higher zinc content in serum and in erythrocytes, they didn't have gastrointestinal complaint or other symptoms for zinc intoxication. Due to low air zinc content in the work place, these high levels of zinc in serum and erythrocytes seem not to be caused by work place contamination. Hereditary hyperzincemia must be considered, but this hereditary abnormality is a very rare case [16], and it is almost impossible to have the 3 cases of hyperzincemia found in the same work place.

Selenium is an essential trace element. It is an antioxidant that plays an important role not only in cancer prevention but also promotes immune system of the human body. Selenium is also as cofactor of glutathion peroxidase, as one of the strongest anti-oxidant in free radical reaction. Selenium in plasma or serum is very well documented. The reported data appear to be quite consistent, apart from disparities attributable to geographical and age dependent factors. In Finland, which is considered as a country with low environmental levels,  $0.0543 \pm .0113 \mu\text{g/mL}$  of Se in serum for a normal subject is reported [17]. In red blood cells, the selenium level is  $0.120 \mu\text{g/g}$  in infants. The Food and Nutrition Board (1980) has recommended dietary intake of 50–200 mg of selenium per day [18]. Toxicity begins at 1 mg per day of inorganic selenium and 2–3 mg per day of organic selenium. Chronic ingestion over periods of weeks or months in selenium rich soil area can produce two effects: the blind staggers, i.e. impaired vision and respiratory failure and alkali disease, a syndrome of liver cirrhosis, loss of hair and emaciation [19]. Acceptable average concentrations exposure (OSHA) for selenium is  $20 \mu\text{g/m}^3$ .

In our study, the airborne selenium in the work place was not detected (below the detection limit). The serum Se level was  $0.069 \pm 0.017 \mu\text{g/mL}$  for workers and  $0.065 \pm 0.028 \mu\text{g/mL}$  for controls. These values were not significantly different, and these data were all within normal limits. As for erythrocytes, the Se level was  $0.56 \pm 0.28 \mu\text{g/g}$  in workers and  $0.45 \pm 0.10 \mu\text{g/g}$  in controls. The cause of this difference is not known. The general conditions for the workers and controls were normal, no sign of any selenosis was observed.

## 5. CONCLUSION

There are a tendency of higher zinc levels in serum and erythrocytes in workers than in healthy individuals (controls). The cause of this is not known yet. No conclusions can be drawn due to lack of data. Further examination of the workers should be performed to eliminate the possibility of intoxication.

## REFERENCES

- [1] WORLD HEALTH ORGANIZATION, Biological Monitoring of Chemical Exposure in the Workplace, Geneva 2 (1996).
- [2] WORLD HEALTH ORGANIZATION, Biological Monitoring of Chemical Exposure in the Workplace, Geneva 1 (1996) 93–96.
- [3] DJOJOSUBROTO, H., WIDJAJAKUSUMA, B., SANTOSO, D., SUPRIATNA, D., Neutron Activation Analysis of Selenium and Zinc in Human Sera of Normal and Cardiovascular Patients, Proceedings of Seminar on Nuclear Science and Technology, Bandung, (1994) 203.

- [4] KATZ, S.A., CHATT, A., The Use of Hair as a Biopsy Tissue for Trace Elements in the Human Body, Application of Hair as an Indicator for Trace element Exposure in Man, A REVIEW, NAHRES-22, International Atomic Energy Agency, Vienna (1994) 11.
- [5] VERSIEK, J. CORNELIS, R., Trace elements in Human Plasma or Serum, CRC Press, Inc. (1989) 50.
- [6] IYENGAR, G.V., Preservation and Preparation of Biological Materials for Trace Element Analysis: Quality Assurance Considerations, Quality Assurance in Biomedical Neutron Activation Analysis, IAEA Tecdoc-323, International Atomic Energy Agency, Vienna (1984) 89.
- [7] KUČERA, J., LENER, J., SOUKAL, L., HORAKOVA, J., Air Pollution and Biological Monitoring of Environmental Exposure to Vanadium Using Short Time Neutron Activation Analysis, J. Trace and Microprobe Techniques **141**(1) (1996) 193.
- [8] HOPKE, P.K., et al., Aerosol Science and Technology **27** (1997)728.
- [9] FOLEY, B.; JOHNSON, S.A., HACKLEY, B., SMITH, J.C., HALSTED, J.A., Zinc content of human platelets, Proc Soc.Exp. Biol. Med. **128** (1968) 2652–269.
- [10] PRASAD, A.S., SCHOOMAKER, E.B., ORTEGA, J., BREWER, G.J., OBERLEAS, D., OELSHLEGEL, F.J., The brole of zinc in man and its deficiency in sickle cell disease, Progress in Clinical and Biological Research, Alan R.Liss, New York (I) (1975) 603–619.
- [11] ROSS, J.F., EBAUGH, F.G., TALBOT, T.R.G., Radioisotopic studies of zinc metabolism in human subjects, Trans. Ass. Amer. Physicians **71** (1958) 81–83.
- [12] PAPP, J.P., Metal fume fever, Post grad.med **43** (1968) 160–163.
- [13] MURPHY, J.V., Intoxication following ingestion of elemental zinc, J. Amer. Med. Ass. **212** (1970) 2119–2120.
- [14] OSLO, A., FARRAR, G.E., PRATT, R., Dispensatory of the U.S, 25<sup>th</sup> ed., Lippin cott, Philadelphia, Pennsylvania, 1520–1521.
- [15] MERCK, The Merck Index, 7<sup>th</sup> ed. 1118, Merck and company Inc.New Jersey (1960).
- [16] VERSIECK, J., VAN BALLEMBERGHE, L., Determination of arsenic and cadmium in human blood serum and packed cells, In Trace elements in man and animals, Commonwealth agricultural bureaux, **5** (1985) 650.
- [17] SALONEN, J.T., ALFTHAN, G., HUTTUNEN, J.K., PUSKA, P., Association between serum selenium and the risk of cancer, Am. J.Epidemiol. **120** (1984) 342.
- [18] NATIONAL RESEARCH COUNCIL, Recommended daily allowances, Washington D.C., National Academy of Sciences (1980) 162–163.
- [19] KINGBURY, J.M., Phytotoxicology in Casarett and Doull's Toxicology, The basic science of poisons, 2<sup>nd</sup> ed. Macmillan Publ. Co. New York (1980) 578–590.

# MONITORING OF AIRBORNE PARTICULATE MATTER (APM), BACKGROUND RADIATION, ANALYSIS OF TRACE METALS AND OTHER PARAMETERS IN SOME PARTS OF KENYA

A.M. KINYUA<sup>1</sup>, C.K. GATEBE<sup>1</sup>, M.J. MANGALA<sup>1</sup>, D.M. MAINA<sup>1</sup>, K. KORIR<sup>1</sup>, G.O. ODHIAMBO<sup>1</sup>, S.K. NDERITU<sup>1</sup>, P. MUSYIMI<sup>1</sup>, J. NJOGU<sup>1</sup>, S. BARTILOL<sup>1</sup>, W.G. MUGERA<sup>2</sup>, G.N. KAMAU<sup>2</sup>, N.O. HASHIM<sup>3</sup>, I.V.S. RATHORE<sup>3</sup>, R.L. STANGL<sup>3</sup>, W. NJUE<sup>4</sup>, M.P. OYUGI<sup>4</sup>, S.C. CHHABRA<sup>4</sup>, J.M. CHAKAYA<sup>5</sup>, M. KARAMA<sup>6</sup>, D.M. MIUNGU<sup>6</sup>, R. KWACH<sup>7</sup>, L.N. NJAU<sup>7</sup>, E.A. MUKOLWE<sup>7</sup>

<sup>1</sup> Institute of Nuclear Science, University of Nairobi, Nairobi, Kenya

<sup>2</sup> Department of Chemistry, University of Nairobi, Nairobi, Kenya

<sup>3</sup> Department of Physics, Kenyatta University, Nairobi, Kenya

<sup>4</sup> Department of Chemistry, Kenyatta University, Nairobi, Kenya

<sup>5</sup> Centre for Respiratory Disease Research, Kenya Medical Research Institute, Nairobi, Kenya

<sup>6</sup> Centre for Public Health Disease, Kenya Medical Research Institute, Nairobi, Kenya

<sup>7</sup> Kenya Meteorological Department, Nairobi, Kenya

## Abstract

This project undertook various studies monitoring workplace environments and assessing some occupational health status. The studies included monitoring levels of airborne particulate matter (APM), natural background radiation, emissions inventory, analysis of trace elements and other parameters in samples collected from various parts of Kenya. The research team published various articles in both local and international refereed journals and participated in various scientific conferences.

Monitoring of outdoor APM levels in Kibera, a residential urban area in Nairobi with a population density of 40,881 people per km<sup>2</sup>, had levels varying from 77.6–159.1 µg/m<sup>3</sup> for samples collected at a height of two (2) metres and 60.9–138 µg/m<sup>3</sup> for samples collected at four (4) metres above the ground. For the samples collected at the two (2) metres height, 66% exceeded the WHO 24 hour guideline of 70 µg/m<sup>3</sup> while at four (4) metres height, only 50% of the samples exceeded this limit. These values are higher than our previous data (30–80 µg/m<sup>3</sup>) reported for a sub-urban site in Nairobi. In addition, the regression analysis of the mean monthly incidences of acute respiratory infections (ARI) of children in Kibera and the coarse APM (PM<sub>10</sub>) and fine (PM<sub>2</sub>) levels showed no significant correlation. This is despite the high rate of ARI incidences observed in this area.

Simulation of the emissions inventory for 1992 found that cement production constituted 96% of the total non-energy source of industrial CO<sub>2</sub> and that lime was mainly used for cement production in Kenya. The pulp and paper industry contributed 89% of total SO<sub>2</sub> emissions while sugar production contributed 55% of all the total no-metallic volatile organic compounds (NMVOC).

Assessment of ozone, nitrogen oxides and trace elements levels present in ambient Nairobi air was also done. The findings of our study showed that levels for Pb, Mn, Fe, Br, Zn, Cu and Ca are within the WHO guidelines. Pb ranged from 0.051 to 1.106 µg/m<sup>3</sup>; Fe, 0.149 to 3.154 µg/m<sup>3</sup>; Mn, 0.002 to 0.526 µg/m<sup>3</sup>; Cu, lower limit of detection (LLD) to 0.15 µg/m<sup>3</sup>; Br, LLD to 0.43 µg/m<sup>3</sup>; Zn, LLD to 0.14 µg/m<sup>3</sup> and Ca, 2.18 to 5.389 µg/m<sup>3</sup>. Concentrations of NO<sub>2</sub>, NO and O<sub>3</sub> were also within the 8-hour WHO limits with levels ranging from 0.011–0.976 ppm for NO, 0.001–0.2628 ppm for NO<sub>2</sub> and LLD-0.1258 ppm for ozone. The O<sub>3</sub> levels were slightly higher in the afternoons when solar intensity was high especially during the days when cloud cover was less than 3 Oktas. PM<sub>10</sub> levels were, however, above the WHO guidelines for most of the days. The mean PM<sub>10</sub> level was (239±126) µg/m<sup>3</sup> while the range was 66.7–444.5 µg/m<sup>3</sup>.

Characterization and transport of aerosols over equatorial eastern Africa revealed that mid-tropospheric elemental aerosol concentrations observed on Mt Kenya are lower than similar findings observed for remote areas in industrialized countries and elsewhere in Africa. However, our results were two orders of magnitude higher than the levels reported from South Pole. Locally derived aerosols were found to be frequently transported by the valley winds up the slopes of Mt Kenya during the day, but rarely at night when stable conditions characterized by down-slope katabatic flow occurred. Night conditions did favor the measurement of long-range, mid-tropospheric transport of products to Kenya. Our study has also revealed that anthropogenically derived S and Fe aerosols from both southernmost and central southern Africa were observed on Mt Kenya after transport over distances exceeding 6000 km. The pristine marine air from the central Indian Ocean was also shown to contain aged and re-circulated Si that could only have been derived from land areas after transport over long distances. The nature of these aerosols measured at Mt Kenya were found to depend critically on regional patterns of aerosol transport and that inter-hemispheric transport across the equator in eastern Africa is a common occurrence. Based on this project, Dr. Gatebe, the principal investigator for Mt Kenya project received the 2000 WMO Award for Young Scientists.

## 1. SCIENTIFIC BACKGROUND AND SCOPE OF PROJECTS

The activities of this CRP have been aimed at seeking ways and means of first, identifying areas of contamination in residential, workplace and manufacturing sectors especially in the urban centres. Secondly, the monitoring of APM and its heavy metal analysis by nuclear and related analytical techniques. Thirdly, characterization and modelling the aerosols transport over eastern Africa. Fourthly, epidemiological case studies especially those associated with acute respiratory infections (ARI) and APM. Fifth, training of postgraduate students and on a consultancy basis, material analysis for clients. These activities have led to the accruing of necessary data and information which some of our relevant government authorities have utilized in the enactment of new legislative act. A case in point is the recent clean air implementation plan, also known as Environmental Management and Coordination Act, 1999 [1]. The government was able to draft this bill after some of our initial studies showed that there was unabated increase in air and water pollution due to industrial, agricultural and transport activities.

The analytical techniques utilized in this project were energy dispersive X ray fluorescence (EDXRF), total reflection X ray fluorescence (TXRF), atomic absorption spectrophotometry (AAS) and proton induced X ray emission (PIXE) among many other analytical procedures. The techniques mentioned are readily available at the University of Nairobi except for PIXE that was done at the University of Witwatersrand, South Africa.

APM was monitored in various workplaces and residential estates by way of the “Gent” stacked filter unit (SFU). The collected APM was analysed for trace elements by use of the nuclear and related analytical techniques (NRAT’s) as indicated above. In addition, APM was also collected by use of the PIXE International two-stage circular streaker sampler. This was situated at Mt Kenya (4420 m above mean sea level on the southwestern slope, 1°S, 37.2°E). The particulate matter collected by use of the streaker was analysed by PIXE at the University of Witwatersrand, South Africa.

The interest in the APM monitoring is to check its effect on health especially the acute respiratory infections, which in Kenya contribute 23% of all the morbidity cases with those in Nairobi accounting for 3%. There is also an interest to find out how much is Kenya’s global contribution to the environmental degradation and the inter-hemispheric transport of aerosols to and from Kenya.

Other studies utilizing NRAT's are aimed at filling the various information and data gaps pertaining to environmental degradation so as to acquire some baseline data on various scientific interests. Some of the current studies by the team include: the levels of radionuclides and trace elements in selected Kenyan coastal ecosystems; environmental studies of industrial emission of airborne particulate matter and its effect on rainwater quality in Athi River town; determination of indoor radon levels using the E-Perm System at Kerio Valley (Soi Division) and Olkaria geothermal site; measurement of respirable particulate matter (PM<sub>10</sub>) levels, trace elements, ozone and nitrogen oxides in the ambient air of Nairobi city plus the physics of radon daughters in relation to smoke aerosols and their role in human dosimetry among other studies.

## 2. EXPERIMENTAL

### 2.1. Sampling of APM

Sampling of APM was done using a 'Gent' Stacked Filter Unit (SFU) [2]. Nuclepore filter membranes (0.4  $\mu\text{m}$  and 8  $\mu\text{m}$ ) were weighed in air-conditioned laboratory controlled at 50% relative humidity and 20°C. <sup>241</sup>Am  $\alpha$ -emitting source (5 $\mu\text{Ci}$ ) was used to remove the static buildup within the filter. Prior to weighing, all filters were left to equilibrate for at least 24 hours. Before the start of each sampling exercise, the SFU was cleaned with ethanol to remove any particles, which may have previously embedded inside. Filters were handled with care using plastic tweezers to avoid grease from fingers and heavy metal contamination. Information recorded was the volume of air sucked by the pump and average weather parameters such as temperature, humidity and wind direction. During sampling, the sampler was run at flow rate of 1 m<sup>3</sup>/hour for 24 hours. The fine and coarse mass concentrations were obtained through gravimetric measurements of Nuclepore filter membranes with 1  $\mu\text{g}$  sensitivity (Ainsworth, type 24N) weighing balance. Before weighing, the filters were always equilibrated for 24 hours at 50% relative humidity and at 20°C before and after air filtration.

### 2.2. Sampling of dust fallout in office environment

Sampling of dust fallout was done at the Institute of Nuclear Science. This was done by placing coarse filters (i.e. 8.0-micron filter) in a petri dish, which was thoroughly cleaned with ethanol. The set-ups were then left at the top of cabinets in various offices for 34 days for the month of January to April 1998 but from May 1998, the days of exposure were reduced to 20 days.

### 2.3. Sampling of APM at Mt Kenya

A two-stage streaker sampler [3] was used to collect samples at a rate of approximately 1L min<sup>-1</sup>. Consequently, particles were partitioned separately into fine fraction, particle-size equivalent aerodynamic diameter  $d_p \leq 2.5 \mu\text{m}$  and coarse fraction  $2.5 < d_p \leq 10 \mu\text{m}$  at mean sea level. However, at our sampling altitude, 4420 m above mean sea level, a pressure of 558 hPa (0.58 atm) and assuming a Brailsford pump maximum capability of 0.4 m (17 inches of vacuum), the flow rate is expected to average 0.5 L min<sup>-1</sup>, and a particle-size equivalent aerodynamic diameter,  $d_p \leq 2.1 \mu\text{m}$  for fine fraction and  $2.1 \mu\text{m} < d_p \leq 8 \mu\text{m}$  for coarse fraction. The samples were taken continuously over a period of 28 days with a time resolution  $\sim$  4hours then analysed with PIXE technique.



## **2.4. X ray fluorescence analysis**

A Canberra S-100 PC based multi-channel analyser (MCA) was used for spectral data acquisition and storage. Both the coarse and fine loaded filters from the 'Ghent' SFU were irradiated at between 50,000 to 60,000 seconds using  $^{109}\text{Cd}$  source to give reasonable statistical accuracy. The loaded filters were placed on the sample holder such that the loaded side faced the source of radiation as per the recommended method [4]. Spectrum data analysis was done using the IAEA software, analysis of X rays by iterative least square fitting (AXIL) which is based on a non-linear least square fitting procedure for optimization of the fitting model (energy and resolution calibration, peak intensities and background parameters) for each spectrum.

Quantitative analysis was done using quantitative analysis of environmental samples (QAES) software, which relates the spectral intensities with the elemental concentrations, based on the fundamental parameter technique [5, 6].

## **2.5. XRF quality control**

A sample pellet of the standard reference material (SRM-1648) from International Atomic Energy Agency (IAEA) was prepared and irradiated for 3000 seconds using  $^{109}\text{Cd}$  source and the spectra analysed using the same procedure.

## **2.6. Sample preparation for atomic absorption spectrometry (AAS) analysis**

The filters were digested by gently boiling in 20 mL of high purity 70% nitric acid for 2 hours [7]. The filters dissolved leaving small particles floating in the solution. This solution was then cooled to room temperature and 10 millilitres of 70% perchloric acid was added and again boiled gently until the particles dissolved. The solution was then cooled to room temperature and 5 ml of distilled water added. The solution was then boiled gently for five minutes, cooled and then made up to 50 ml in 1% nitric acid solution.

## **2.7. Quantitative analysis by AAS**

Quantitative analysis was done by atomic absorption spectrometer Model AA-680 that uses a hollow cathode lamp and had wavelength range of (190-900) nm as previously discussed [8]. The Model AA-680 is composed of the spectrophotometer, the graphic printer, the gas control unit and the color graphic cathode ray tube (CRT) display. It is capable of performing quantitative analysis based on atomic absorption and flame emission spectrometry.

## **2.8. AAS quality control**

A standard reference material (Urban Particulate Matter-1648) from International Atomic Energy Agency (IAEA) was analysed using the same procedure and the results had a variation of less than 10 % from the certified value for the elements analysed.

Standard solutions for calibration of the spectrophotometer were prepared before analysis from 1000 ppm stock solutions (analar reagents) prepared in 1M Nitric acid solutions. Standard solutions were prepared for lead (Pb), manganese (Mn), copper (Cu), nickel (Ni), iron (Fe) and zinc (Zn). The concentration range of the standards was as per the specifications

of the spectrometer, i.e. 1-6  $\mu\text{g}/\text{mL}$ . The standards were then utilized by the spectrometer for plotting the calibration curves for the various elements analysed.

## **2.9. PIXE set-up**

For PIXE analysis, a proton beam (collimated with a rectangular collimator) with a proton beam of 3.2 MeV, and a current of 10 nA provided by tandem accelerator at Schonland Research Centre for Nuclear Science, University of Witwatersrand, South Africa. Irradiation times were 600 seconds.

Samples were also analysed at PIXE Analytical Laboratories, Tallahassee, FL, USA using a 2.4 MeV proton beam from a tandem accelerator [2]. The circular stalker sample frame was inserted into a sample manipulator that automatically steps the filter in 168, 1 mm wide increments, equivalent to a time resolution of 4 sampling hours for each step. Each sample was irradiated, with a 1x7 mm collimated beam, for 6 minutes (120 seconds with the X ray absorber out and 240 seconds with the absorber inserted). Because the stalker orifice moves and samples continuously along the filter, whereas the PIXE analysis is performed on consecutive 1 mm segments of the sample streak, every measurement is serially correlated by 25% with the immediate and subsequent measurements [2]. Therefore, each concentration is only 50% representative of the ambient concentration during the 4 h time step.

## **2.10. PIXE quality control and analysis**

The PIXE systems were calibrated by a large number of Micromatter Standards (mono and bi-elemental) of known area density (5% uncertainties certified). The fitting of its X ray spectra and quantitative analysis was performed using the AXIL-PC software and WITS-HEX [2]. The elemental concentrations in the irradiated samples were determined by deconvolution of the resulting peaks [2]. The calculations of amounts were made using a calibration based on thin-film standards of the elements and analytical detection limit for each element was based on two standard deviations of the background noise in the corresponding region of the spectrum [3, 9].

# **3. RESULTS AND DISCUSSION**

## **3.1. Quality control measurements**

Analysis of SRMs and detection level measurements for AAS and EDXRF techniques is shown in Tables I–III.

## **3.2. APM level changes**

The  $\text{PM}_{10}$  levels for the various sites (Figs. 1 and 2) reflect the location, surrounding ground activities and the nature of the ground cover. Site D which was nearest to the an unpaved road (i.e. 3 m) recorded the highest levels ( $233.85 \mu\text{g}/\text{m}^3$ ) for the coarse particles while site E which was away from any road or footpath recorded the lowest levels, because the ground cover was mainly rock hence less soil dust. Except site E, all the sites in the slum area recorded values greater than  $150 \mu\text{g}/\text{m}^3$  (Figs. 1 and 2). The levels for the fine particles show a similar trend for all the sites. Site D again recorded high values (highest  $35.70 \mu\text{g}/\text{m}^3$ ),

A-26.30  $\mu\text{g}/\text{m}^3$ , while B recorded the highest in May (42.36  $\mu\text{g}/\text{m}^3$ ). Site E recorded the lowest values (6.44  $\mu\text{g}/\text{m}^3$ ) in June.

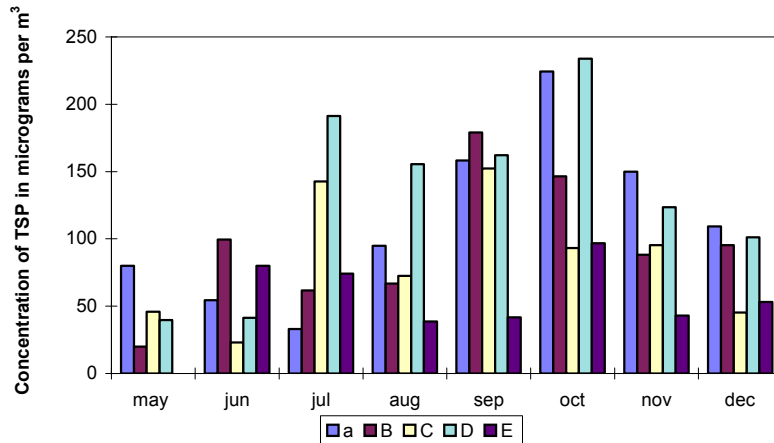

FIG. 1. Variation of coarse APM for the various sampling sites.

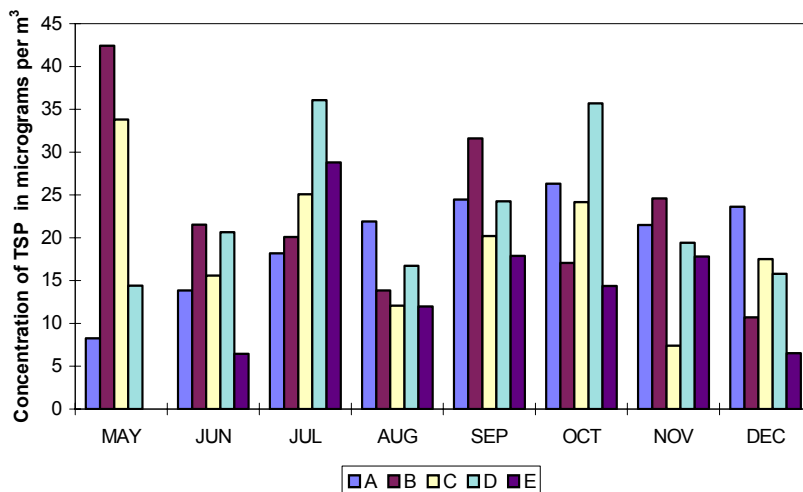

FIG. 2. Variation of fine APM for the various sampling sites.

The  $\text{PM}_{10}$  levels were found to follow a seasonal trend for all the sites. Rainfall pattern during the year 1998 is shown in Fig 3. Variation from the general trend occurred for some sites due to the changes in the weather parameters mainly humidity, temperature and rainfall. For the coarse particles, levels were low in May and June. These were the months characterized by heavy rainfall (long rains) and high humidity (Fig 4). The zone levels then increased from July to August 1998. These months are characterized by cold conditions and high humidity. The high levels of APM were attributed to the increased emissions from residential burning of fuels. This was followed by rapid increase in September and October. These months are usually characterized by a dry spell. Hence the increase is attributed to the high level of soil dust. The APM levels decreased in November and December 1998. These months are also characterised by a dry spell but it should be noted that for the month of December, the SFU was at a higher height (4 m) unlike the sampling of May to November 1998, which was done at 2 m from the ground.

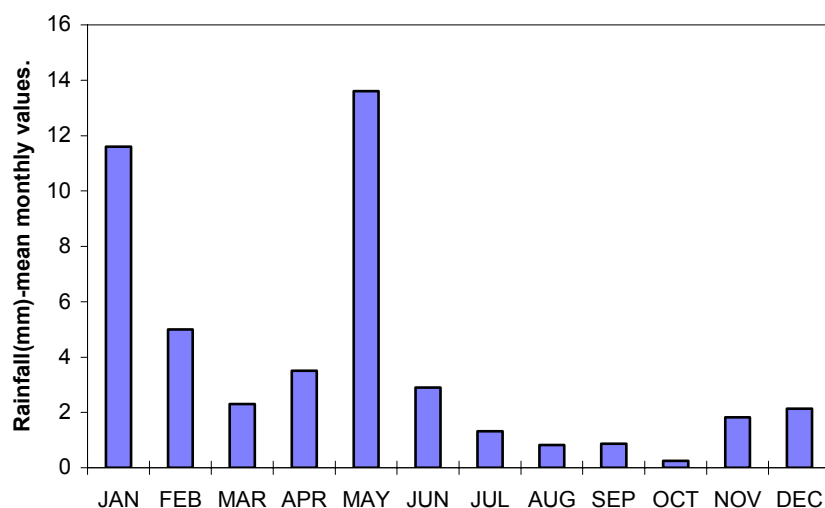

FIG. 3. Rainfall pattern in Dagoretti [10].

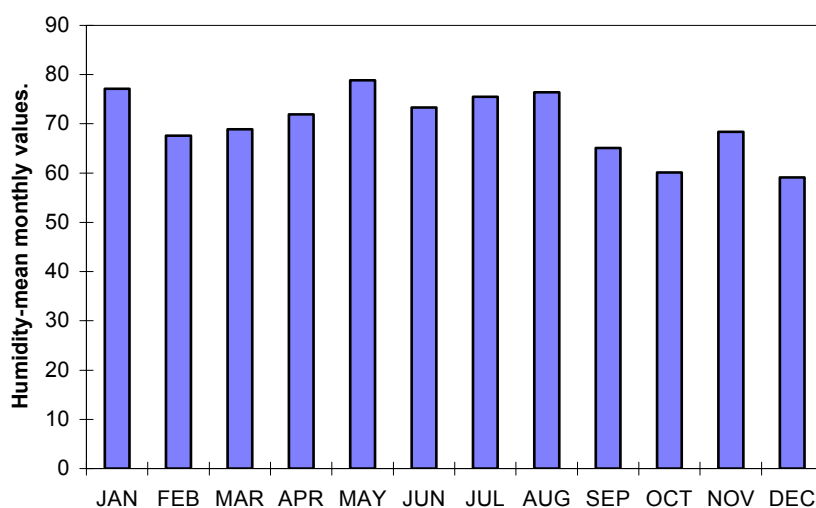

FIG. 4. Variation of humidity in Nairobi [10].

### 3.3. Elemental levels

Results for elemental concentration analysed by Atomic Absorption Spectrophotometry (AAS) and Energy Dispersive X ray Fluorescence (EDXRF) are as listed below. The results presented are for the months of June to November 1998. The data on APM collected over the eight-month period (May-December) had the coarse particles ( $8.0 \mu\text{m}$ ) ranging from  $62.4\text{--}107.5 \mu\text{m}/\text{m}^3$  whereas the fine particles ranged from  $16.2\text{--}24.4 \mu\text{m}/\text{m}^3$ . The elemental levels ( $\mu\text{m}/\text{m}^3$ ) for coarse particles were as follows: K (0.83–4.53), Ca (5.19–7.80), Ti (0.39–0.81), Mn (0.38–0.79), Fe (3.49–6.03), Cu (0.12–0.17), Zn (0.14–0.25), Pb (0.17–0.34), Br (0.03–0.06) and Zr (0.05–0.15). For the fine particles, the elemental concentrations were: K (0.56–1.79), Ca (3.12–6.30), Ti (0.06–0.28), Mn (0.08–0.11), Fe (0.86–1.23), Cu (0.08–0.14), Zn (0.11–0.15), Pb (0.17–0.25), Br (0.03–0.06) and Zr (0.01–0.03). Cu, Zn, Pb and Br were also found to have high enrichment factors both for the coarse and fine fractions. For the coarse particles, the enrichment factors were: Cu (16–34), Zn (12–18), Pb (102–302) and Br (153–496).

whereas for the fine particles the factors were: Cu (22–41), Zn (36–66), Pb (513–804) and Br (965–1489).

TABLE I: AAS ANALYSIS OF SRM (IAEA –1648)

Element	Concentration (%), n = 3	Certified Value (%)	Error (%)
Cd	0.00763	0.0075	+1.76
Fe	3.78	3.91	-3.23
Pb	0.627	0.655	-4.74
Zn	0.463	0.476	-2.64
Cu	0.0600	0.0609	-1.52
Ni	0.0076	0.0082	-6.91

TABLE II: EDXRF ANALYSIS OF SRM (IAEA-1648)

Element	Concentration (%), n = 3	Certified Value (%)	Error (%)
K	1.11	1.05	+5.7
Cr	0.0371	0.0403	-7.9
Fe	3.74	3.91	-4.4
Cu	0.0605	0.0609	-0.7
Pb	0.605	0.655	-7.6
Zn	0.449	0.476	-5.6

The lower detection limits (LDL) for the various elements (Table III) have been calculated [11] for the EDXRF using the following equation:

$$Det\ Limit = \frac{3.C}{N_p} \sqrt{N_B}$$

where

C is the concentration of the element in  $\mu\text{g}/\text{m}^3$ .

$N_p$  is the net peak area for the element.

$N_B$  is the net background area under the element peak.

TABLE III: TYPICAL LOWER DETECTION LIMITS FOR EDXRF FOR COARSE APM

Element	Lower detection limits ( $\mu\text{g}/\text{m}^3$ )
K	1.237
Ca	0.862
Ti	0.301
Mn	0.0621
Fe	0.0489
Cu	0.0493
Zn	0.0284
Br	0.01992
Zr	0.00682
Pb	0.0364

### 3.4. Acute respiratory infections

Results of ARI Monitoring are shown in Table IV. The point prevalence of ARI in 1998 ranged between 29.9% in January to the highest level of 59.6% in June. The total number of children, who presented themselves continuously under surveillance throughout the study period, January–December 1998, was 146. The average ARI incidence was found to be  $8.49 \pm 4.01$  episodes per child per year. Throughout the year, the ARI point prevalence showed a seasonal variation with the cold months of May–August having the highest percentages (57.9, 59.6, 54.0 and 44.1 respectively). For the relatively hot months of September to December these percentages (55.3, 49.0, 48.6 and 31.9 respectively) dropped.

For both sites, only small and insignificant associations were detected for both PM<sub>10</sub> and PM<sub>2.0</sub>. This can be seen from the small F values obtained. Site B had high values for PM<sub>2.0</sub> although still non-significant at P = 0.01 and P = 0.05 level. For both sites B and E, only 10–15% of the variation of the ARI incidences could be explained by the variation of the PM<sub>10</sub> and PM<sub>2.0</sub>. However for site B, PM<sub>2.0</sub> accounted for 51.0% of the total variation of the ARI incidences.

TABLE IV: CHILDREN CONTACTED AND % OF THE ARI EPISODES PER MONTH FOR 1998\*

Month	Jan	Feb	Mar	Apr	May	Jun	Jul	Aug	Sep	Oct	Nov	Dec
Children #	724	754	781	808	836	857	661	624	651	621	661	646
Visit (%) 1	23.2	36.6	30.7	36.1	41.5	37.1	36.9	37.5	35.9	28.7	28.6	21.7
2	5.7	9.0	9.4	13.7	16.4	22.5	17.1	6.6	13.4	13.5	15.6	8.2
3									4.0	5.0	4.1	2.0
4									2.0	1.8	0.3	–
Total (%)	29.9	45.6	40.1	49.8	57.9	59.6	54.0	44.1	55.3	49.0	48.6	31.9

\* ARI progress reports [KEMRI/JICA, 1998]

Nb: % refers to the number of children with ARI on examination.

Actual and predicted cases of ARI for Site B and E with respect to PM<sub>10</sub> and PM<sub>2.0</sub> from May through December 1998 are shown in Table V.

TABLE V: ACTUAL AND PREDICTED ARI CASES

	Site B (n=8)				Site E (n=7)			
	PM <sub>10</sub>		PM <sub>2.0</sub>		PM <sub>10</sub>		PM <sub>2.0</sub>	
	Actual	Predicted	Actual	Predicted	Actual	Predicted	Actual	Predicted
May	57.9	49.0	57.9	62.4	ND	ND	ND	ND
Jun	59.6	50.2	59.6	49.3	59.6	48.6	59.6	45.3
Jul	54.0	49.4	54.0	48.5	54.0	51.9	54.0	54.9
Aug	44.1	49.4	44.1	44.5	44.1	44.7	44.1	47.7
Sept	55.3	52.0	55.3	55.7	55.3	46.5	55.3	50.2
Oct	49.0	51.0	49.0	46.6	49.0	53.8	49.0	48.7
Nov	48.6	50.1	48.6	51.3	48.6	45.9	48.6	50.2
Dec	31.9	49.9	42.6	40.2	31.9	45.7	31.9	45.4

ND – not determined

### 3.5. Emissions inventory for Kenya

In summary, it was found that for the emissions inventory, cement production constitutes 96% of the total non-energy source of industrial CO<sub>2</sub> in 1992 and that lime was mainly used for cement production in Kenya [12, 13]. The pulp and paper industry constitutes 89% of total SO<sub>2</sub> emissions while sugar production constituted 55% of the entire total NMVOC. The next steps include estimates of emissions from chemical and metal industries, emissions from mineral products and the production and use of halocarbons.

Although extensive studies on exposure and health due to air pollution have not been undertaken in Kenya, cases of occupational asthma, byssinosis, silicosis and asbestosis have been reported from industrial workers in battery manufacturing, cement production and mineral processing in Nairobi, Athi River, Thika and Mombasa [14]. Other studies [15, 16] have previously revealed that some of the occupational diseases are becoming a growing problem in Kenya as a result of the rapid rate of industrialisation.

A study on domestic air pollution from biomass burning in a rural area did not detect any relationship between the number of acute respiratory episodes of the children and indoor air quality. But recent studies [7] showed the acute respiratory infections (ARI) incidences ranging from 29.9–59.6% while the average ARI incidences was  $8.49 \pm 4.01$  episodes per child per year. The ARI incidences point prevalence also showed a seasonal trend with both the cold and dry seasons having high point prevalence. However, the regression analysis of monthly mean ARI incidences of children under five (5) years of age on total APM and the fine particulate levels showed no significant correlation. This could have been due to the short duration (one-year) of this study. Previously, a study was carried out considering the total monthly and seasonal variation of pneumonia in Nairobi and establishing that the months corresponding to the onset of the long rain seasons had the highest number of patients [17]. It was noted that there was higher number of cases of pneumonia during the cold seasons. This high number of pneumonia cases during the onset of rainy season was attributed to the characteristic dry and dusty conditions prior to the onset of rains hence probability of viruses and bacteria being transported in the dust and when inhaled resulting in the diseases.

The studies carried out [7] have also shown that the mean APM values were varying from 77.6–159.1  $\mu\text{g}/\text{m}^3$ . These were for samples collected at a height of two (2) metres and 60.9–138  $\mu\text{g}/\text{m}^3$  at four (4) metres above the ground. For the samples collected at the two (2) metres height, 66% exceeded the WHO 24 hour guideline of 70  $\mu\text{g}/\text{m}^3$  while at four (4) metres height, only 50% of the samples exceeded this limit. This was mainly due to the high levels of resuspended soil dust at two (2) metres height. These values are higher than previous data (30–80  $\mu\text{g}/\text{m}^3$ ) reported for a sub-urban site in Nairobi [5, 18, 2]. Although direct comparison of results is difficult due to different sampling protocols, the APM data obtained in this work is lower than that reported in urban sites in Asia (15–219  $\mu\text{g}/\text{m}^3$ ) and higher than that reported in urban and sub-urban sites in United States of America (1–97  $\mu\text{g}/\text{m}^3$ ) and Europe (2.1–74.2  $\mu\text{g}/\text{m}^3$ ). The APM levels also varied with the weather conditions. Mean monthly values showed a strong seasonal trend with the highest values observed during the cold (51.3–227.4  $\mu\text{g}/\text{m}^3$ ) and dry (60.8–269.6  $\mu\text{g}/\text{m}^3$ ) seasons. This was probably due to the high levels of soil dust during the dry season and increased residential emissions from the domestic heating (mainly wood/charcoal and kerosene fuels) during the cold season.

This study does point out a deteriorating air quality in Nairobi and that major sources of air pollution are the vehicular and industrial emissions. It was also shown that there is transboundary movement of air pollutants into Kenya, which need to be taken seriously [3, 9, 19]. As a result of the above-related air pollution studies and other national requirements, there is now effort being made to enact laws aimed at regulating emissions into the atmosphere. This will be through the enactment by the Parliament of Kenya, a Bill on the Environmental Management and Coordination Act, 1999 [1]. It is also hoped that the establishment of National Environment Council and a National Environment Management Authority will initiate systematic air quality monitoring in Nairobi.

### **3.6. Assessment of levels of respirable particulate matter (PM<sub>10</sub>), trace elements, ozone and nitrogen oxides in the ambient air of Nairobi city**

Motor vehicle emissions are a major source of air pollution in most urban centers. In Kenya, Nairobi City has the highest traffic density and is therefore a particular cause for concern due to the poor maintenance standards of most vehicles plus the use of leaded gasoline. This study [20] was carried out to determine the levels of nitrogen oxides (NO<sub>x</sub>), APM (PM<sub>10</sub>), ozone (O<sub>3</sub>) and heavy metals in the APM collected from the ambient air of Nairobi City. Sampling was done once every week for a period of three months (February to April 2000). Hourly average concentrations of NO<sub>2</sub>, NO and O<sub>3</sub> were measured simultaneously from 9.00 am to 5.00 pm, at a roundabout connecting two main highways (University and Uhuru) in the city. PM<sub>10</sub> was collected using "Gent" Stacked Filter Unit (SFU) air sampler on nucleopore filters (0.4 and 8.0 µm pore size for fine and coarse filters respectively) which were weighed and analysed for trace elements by energy dispersive X ray Fluorescent (EDXRF) technique. Nitrogen oxides were analysed with ThermoElectron's Chemiluminescent NO<sub>x</sub> Model 14B analyser while ozone was by using DASIBI ozone monitor, Model 1003 AH. An automatic vehicle counter was used for determining the vehicle density at the sampling point. The findings of the study show that the values obtained for Pb, Mn, Fe, Br, Zn, Cu and Ca are within the WHO guidelines. Lead concentrations ranged from 0.051 to 1.106 µg/m<sup>3</sup>; Fe, 0.149 to 3.154 µg/m<sup>3</sup>; Mn, 0.002 to 0.526 µg/m<sup>3</sup>; Cu, lower limit of detection to 0.15 µg/m<sup>3</sup>; Br, LLD to 0.43 µg/m<sup>3</sup>; Zn, LLD to 0.14 µg/m<sup>3</sup> and Ca 2.18 to 5.389 µg/m<sup>3</sup>. Concentrations of NO<sub>2</sub>, NO and O<sub>3</sub> were also within the 8-hour WHO limits with levels ranging from 0.011–0.976 ppm for NO, 0.001–0.2628 ppm for NO<sub>2</sub> and LLD-0.1258 ppm for ozone. The O<sub>3</sub> levels were slightly higher in the afternoons when solar intensity was high especially the days with cloud cover of less than 3 Oktas. PM<sub>10</sub> levels were, however, above the WHO guidelines for most of the days. The mean (PM<sub>10</sub>) was 239 µg/m<sup>3</sup> while the range was 66.657–444.45 µg/m<sup>3</sup>. In the dry months of February and March, coarse particulate accounts for more than 70% of PM<sub>10</sub>. Analysis of the data shows strong correlation ( $r^2 = 0.966$ ) between fine (0.4 µm) particles and NO, indicating the importance of traffic as a common source for both fine particles and NO. Coarse particles, NO<sub>2</sub> and O<sub>3</sub>, however show poor correlation with motor vehicle density. There is also positive correlation between Pb and Br ( $r^2 = 0.930$ ), while Fe, Ca and Mn are positively correlated with coarse particulate matter. The high correlation between Pb and Br and motor vehicles suggests their main source as motor vehicle emission. Ca, Fe and Mn are most probably from resuspended dust particles since they correlate well with coarse particles. The health implications of these results are also discussed.



### 3.7. Characterization and Transport of Aerosols over Equatorial Eastern Africa

Measurements of the composition of aerosol partitioned into two size fractions, fine (particle aerodynamic equivalent diameter,  $d_p \leq 2.5 \mu\text{m}$ ) and coarse ( $2.5 < d_p \leq 10 \mu\text{m}$ ) were made at a high altitude site over equatorial eastern Africa on Mt Kenya to study long-range transport of aerosol and determine the extent of inter-hemispheric transport at the equator [21, 3, 9, 19]. The results obtained are shown in Tables 6 and 7. The two size fractions allow long-range transport aerosol to be distinguished from those more locally derived. Background mid-tropospheric elemental aerosol concentrations observed on Mt. Kenya are lower than commensurate findings for remote areas in industrialized countries and elsewhere in Africa, but two orders of magnitude higher than concentrations reported from South Pole. Locally derived aerosols are frequently transported up the slopes of Mt. Kenya by day in valley winds, but rarely at night in the stable conditions characterized by down-slope katabatic flow. Nocturnal conditions favor the measurement of long-range, mid-tropospheric transport products to Kenya from afar. Case studies reveal that anthropogenically derived S and Fe aerosols from both southernmost and central southern Africa may be observed on Mt. Kenya after transport over distances exceeding 6000 km. So-called pristine marine air from the central Indian Ocean is shown to contain aged and recirculated Si that could only have been derived from land areas after transport over long distances. The nature of the aerosols measured on Mt. Kenya depends critically on regional patterns of aerosol transport. Inter-regional transfers are a feature of the transport climatology. Likewise inter-hemispheric transport across the equator in east Africa is of common occurrence.

TABLE VI: FINE FRACTION ELEMENTAL DETECTION LIMIT ( $\mu\text{g}/\text{m}^3$ ), PERCENTAGE OF WEIGHT FRACTION, MEDIAN AND MAXIMUM CONCENTRATION ( $\mu\text{g}/\text{m}^3$ ) OF THE ELEMENTS PRESENT IN THE SAMPLE ON MT. KENYA AT 4420 M ABOVE MEAN SEA LEVEL DURING AUGUST TO SEPTEMBER 1997 PERIOD.

Elements	Detection limit	Percentage of detected mass	Cumulative percentage	Median concentration	Maximum concentration
Si	0.021	48.9	48.9	0.481	1.100
S	0.017	17.6	66.5	0.157	1.056
Na	0.065	12.7	79.2	<0.067	0.191
Cl	0.016	4.8	84.0	0.046	0.165
K	0.012	4.1	88.1	0.030	0.25
Ca	0.010	2.6	90.7	0.014	0.121
Fe	0.003	2.2	92.9	0.019	0.110
P	0.022	2.1	95.0	<0.022	0.037
V	0.005	0.9	95.9	<0.005	0.013
Ti	0.006	0.8	96.7	<0.007	0.019
Pb	0.008	0.8	97.5	<0.008	0.023
Cr	0.004	0.7	98.2	<0.004	0.011
Br	0.005	0.5	98.7	<0.005	0.015
Se	0.003	0.4	99.1	<0.003	0.008
Mn	0.003	0.2	99.3	<0.003	0.008
Cu	0.002	0.2	99.5	<0.002	0.006
Zn	0.002	0.2	99.7	<0.002	0.006
As	0.003	0.2	99.9	<0.002	0.008
Ni	0.002	0.1	100	<0.002	0.005

TABLE VII: COARSE FRACTION ELEMENTAL DETECTION LIMIT ( $\mu\text{g}/\text{m}^3$ ), PERCENTAGE OF WEIGHT FRACTION MEDIAN AND MAXIMUM CONCENTRATION ( $\mu\text{g}/\text{m}^3$ ) OF THE ELEMENTS PRESENT IN THE SAMPLE ON MT KENYA AT 4420 M ABOVE MEAN SEA LEVEL DURING AUGUST TO SEPTEMBER 1997 PERIOD

Elements	Detection limit	Percentage of detected mass	Cumulative Percentage	Median Concentration	Maximum concentration
Si	0.018	23.2	23.2	0.342	1.368
Na	0.053	16.4	39.6	<0.065	0.712
Pb	0.005	12.0	51.6	<0.005	0.041
Fe	0.002	8.5	60.1	0.118	0.509
Ca	0.008	8.0	68.1	0.082	0.759
Al	0.023	6.7	74.1	0.074	0.403
As	0.002	6.6	81.4	<0.002	0.026
P	0.018	6.3	87.7	0.036	0.122
Cl	0.012	4.2	91.9	0.048	0.322
K	0.008	2.4	94.3	0.082	0.759
Sr	0.005	1.7	96.0	<0.005	0.022
Ti	0.005	1.1	97.1	0.015	0.061
Zn	0.001	1.0	98.1	0.010	0.065
Cu	0.001	0.6	98.7	<0.001	0.097
Mn	0.002	0.4	99.1	0.004	0.050
V	0.0048	0.3	99.4	<0.005	0.010
Cr	0.003	0.2	99.6	<0.003	0.008
Ni	0.002	0.2	99.8	<0.002	0.007
Br	0.003	0.2	100.0	<0.003	0.013

## REFERENCES

- [1] KENYA GAZETTE Supplement Bills, The Environmental Management and Coordination Bill, 1999, Republic of Kenya, Government Printer, Nairobi (1999) 215–346.
- [2] GATEBE, C.K., KINYUA, A.M., MANGALA, M.J., KWACH, R., NJAU, L.N., MUKWOLWE, E.A., MAINA, D.M., The determination of suspended particulate matter of major significance to human health using Nuclear Techniques in Kenya, *J. Radioanal. Nucl. Chem.* **203**(1) (1996b) 125–134.
- [3] GATEBE, C.K., TYSON, P.D., ANNEGARN, H.J., KINYUA, A.M., HELAS, G., PIKETH, S.J., Aerosol Transport over Equatorial Africa, American Geophysical Union, Spring Meeting **80** (1999a) (17). Poster A22C-03 (1999) (Supplement, p. 37).
- [4] INTERNATIONAL ATOMIC ENERGY AGENCY (IAEA), IAEA TECDOC Operation Guide on Sampling, Storage and Sample Preparation Procedures for XRF analysis of Environmental Samples (1996) 45–46.
- [5] KINYUA, A.M., et al., Workplace Monitoring and Occupational Health Studies in Kenya using Nuclear and Related Analytical Techniques, IAEA CRP KEN/9478 (1998a).

- [6] KINYUA, A.M., Multi-elemental analysis of solids and liquid samples by X ray fluorescence, M.Sc. Thesis, University of Nairobi (1982).
- [7] GITARI, W.M., KINYUA, A.M., KAMAU, G.N., GATEBE, C.K., Elemental composition of fine and coarse suspended particulate matter (SPM) and Acute Respiratory Infection (ARI) Monitoring in Kibera, Nairobi, Kenya, Proceedings of 5<sup>th</sup> Kenya Meteorological Society Workshop, Mombasa, Kenya, 4–8<sup>th</sup> September, 2000 (2000).
- [8] JUMBA, I.O., M.Sc. Thesis, University of Nairobi (1980).
- [9] GATEBE, C.K., Characterization and transport of atmospheric aerosols sampled at a high altitude on Mt. Kenya, unpublished Ph.D. thesis, University of Witwatersrand, Johannesburg, South Africa. (1999b).
- [10] Kenya Meteorological Department (KMD), Ministry of Transport and Communications, Republic of Kenya, Nairobi Meteorological Data (1998).
- [11] WOBRAUSCHEK, P., Total reflection X ray fluorescence analysis with polarized radiation, *J. Trace and Microprobe Techniques* **13**(2) (1995) 83–96.
- [12] KINYUA, A.M., Emissions inventory for Kenya, Report submitted to WHO (2000).
- [13] GATEBE, C.K., ITULI, J., KINYUA, A.M., A National GHG's Inventory Workshop, Inventorization of GHG's emissions from Industries in Kenya; paper presented under UNDP/GEF PROJECT: Building Capacity in Sub-Saharan Africa to respond to the UNFCCC on Climate Change, 18–20 December (1996a).
- [14] KAHENYA, P.N.P., A review of studies on occupational diseases in Kenya, *African Newslett on Occupational Health and Safety Supplement* **2** (1996) 46–49.
- [15] KENNY, T., Northern Corridor Transport Project: Adverse social and environmental impacts caused by the rehabilitation of the Westlands-St. Austins and Kabete-Limuru roads, Kenya, Oxfam UK/Ireland Policy Department (1996).
- [16] MURIUKI, A.W., Report of Air Emissions in and around Kamiti Tanners Ltd., Directorate of Occupational Health and Safety Services, Ministry of Labour, Government of Kenya (1995).
- [17] GIKUNGU, D.I., Seasonal variation of pneumonia in Nairobi. Kenya Meteorological Department and Directorate of Meteorology (United Republic of Tanzania), Proceedings of the Third Technical Conference on the Meteorological Research in Eastern and Southern Africa, Arusha, Tanzania (1993) 185.
- [18] KINYUA, A.M., MANGALA, M.J., GATEBE, C.K., KAMAU, G.N., KWACH, R., MUGERA, W.G., KORIR, I., MUKOLWE, E.A., Suspended particulate matter in Nairobi and the impact on health, Proceedings of 4<sup>th</sup> Kenya Meteorological Society (KMS) Workshop on Meteorological Research, Applications and Services, Nairobi, 416–420 (1998b).
- [19] GATEBE, C.K., TYSON, P.D., ANNEGARN, H.J., PIKETH, S., HELAS, G., A seasonal air transport climatology for Kenya, *J. Geophys. Res.* **104**(D12) (1998) 14237–14244.
- [20] ODHIAMBO, G.O., Assessment of Levels of Respirable particulate Matter (PM<sub>10</sub>), Trace Elements, Ozone and Nitrogen oxides in the Ambient Air of Nairobi City, M.Sc. Thesis, University of Nairobi (2001).
- [21] GATEBE, C.K., TYSON, P.D., ANNEGARN, H.J., HELAS, G., KINYUA, A.M., PIKETH, S.J., Characterization and Transport of Aerosols over Equatorial Eastern Africa, *Journal of Global Biogeochemical Cycle* **15**(3) (2001) 663–672.

# PARTICULATE MATTER AND HEALTH - FROM AIR TO HUMAN LUNGS<sup>1</sup>

T. PINHEIRO<sup>1</sup>, A. BUGALHO DE ALMEIDA<sup>2</sup>, P. MONTEIRO<sup>2</sup>, E. ALVAREZ<sup>2</sup>,  
D. MONIZ<sup>2</sup>, L.C. ALVES<sup>1</sup>, M.C. FREITAS<sup>3</sup>

<sup>1</sup> Nuclear and Technological Institute, Physics Department, Sacavém, Portugal

<sup>2</sup> Faculty of Medicine, Lisbon University, Lisbon, Portugal

<sup>3</sup> Nuclear and Technological Institute, Sacavém, Portugal

## Abstract

This work reports on the environmental influence in the respiratory health of workers exposed to metal pollutants in their labour activities (metal processing industry). The clinical, respiratory functional and morphological changes were related with blood elemental concentrations in order to evaluate the influence of exposure to inhaled metal airborne particles. In addition, the deposition of particulate matter in the respiratory system was assessed in humans and in an animal model to infer possible mechanisms of interaction of metals with the respiratory tissue. The respiratory affections encountered for the exposure group through clinical, functional and morphological data are related with the number of years of exposure and with high levels of Zn in blood. Methodologies applied have into account the quality of results produced. Interlaboratory checks were carried out using certified reference materials and standard procedures were initiated to assure traceability in chemical analysis of biological matrices using analytical techniques based on X ray spectrometry.

## 1. INTRODUCTION

Growing awareness of environment degradation in a way that may influence health reflects on increasing epidemiological and toxicological studies permitted to estimate the total burden of disease (mortality and morbidity) attributable to anthropogenic sources [1–3]. Exposure to airborne particulate matter (PM) of different aerodynamic dimensions, PM<sub>10</sub> and PM<sub>2.5</sub>, has been associated with several pathological and inflammatory conditions as occurs in asthma and chronic obstructive pulmonary disease, which reflects on remarkable deterioration of quality of life and significant increase in health care burden [4, 5]. Pro-inflammatory effects of transition metals, hydrocarbons, ultrafine particles and endotoxin, all present in varying degrees in inhaled air could be significant, although lifestyle factors play an important role, such as, smoking [6]. An understanding of the different components of particulate matter contribution in exacerbating pulmonary affections is essential before proper risk assessment can be undertaken leading to advice on risk management for those that are largely exposed to air pollution particles. Thus, a clear understanding of the effective dose that can trigger or exacerbate disease condition should include toxicological studies and subsequently, biomonitoring of exposed individuals.

The work carried out allowed gathering clinical, morphological and physiological data for a population exposed to metal airborne particles (steel processing industry) and permitted to characterise aerosols at the workplace. The experience gained and results obtained will contribute to better design future programmes on the evaluation of health condition of

---

<sup>1</sup>Work performed under the IAEA coordinated research programme - Assessment of Levels and Health Effects of Airborne Particulate Matter in Mining, Metal Refining and Metal Working Industries Using Nuclear and Related Analytical Techniques.

workers exposed to specific indoor pollutants. In addition, data gathered will open perspectives for future research in the mechanisms of diseases, where environment is a recognised risk factor.

## 2. DESCRIPTION OF WORK

The work carried out will be summarised in the subsequent sections. A short description of methodologies will be presented and the results from Quality Assurance tests performed for the experimental protocols followed will be shown. The exposure influence on a group of workers from a steel processing plant will be discussed taking into account their blood elemental concentrations and the characterization of the particulate matter (PM) that can be inhaled by workers on their labour activity. A synopsis of the results obtained for deposition and diffusion of metal components of PM in the respiratory tissue will be introduced and discussed. Data obtained for the human respiratory system will be compared with data gathered from an animal model, exposed to the same environment of the surveyed workers.

### 2.1. Methods applied

#### 2.1.1. Group characterization and blood sampling

The population group studied consisted of seventy workers (all men) with ages ranging between 39 to 55 years, working at the steel factory (Siderurgia Nacional EP, Portugal) for more than 15 years. Each individual was subjected to a medical examination, lung function tests, thoracic radiography, and was questioned for his medical history, most recent complains and living habits, alcohol and tobacco consumption. Symptoms and signs, pulmonary function tests, vital capacity (VC), forced expiratory volume in one second (FEV<sub>1</sub>), forced vital capacity (FVC), forced expiratory flow at 75%, 50%, 25% of FVC, and chest radiography diagnosed airway limitation in exposed workers. For lung function alterations and degree of opacities observed in chest radiographs the codes assigned were in conformity with the International Labour Office proposed classification of radiographs of the pneumoconioses, ILO-80 [7].

Blood was collected for elemental content determination both in serum (S) and packed blood cells (PBC) or total blood (TB). Blood samples were collected by venopuncture in polyethylene tubes that were previously thoroughly cleaned in nitric acid, washed with distilled water and dried in a clean bench, as described elsewhere [8, 9]. Serum was separated from PBC fraction by centrifugation. All samples were freeze-dried and stored at -30°C. Wet and dry weights were determined for both blood fractions. Blood elemental concentrations of the exposed group were referred to values obtained from a non-exposed Portuguese group of 58 men and 70 women with ages comprised between 20 and 65 years [9, 10]. The reference limits were calculated according to IUPAC recommendations for the 0.90 coverage interval of the non-parametric distribution and for a coverage uncertainty of 95%. [11].

#### 2.1.2. Aerosol sampling and exposure estimation

For exposure estimation, the elemental characterization of airborne particulate matter was assessed at the work place and blood elemental concentrations of exposed subjects were determined. Stationary sampling was carried out with a Gent PM10 sampler equipped with NILU (Norwegian Institute for Air Research) stacked filter units that use

47 mm Costar-Nuclepore filters with 8  $\mu\text{m}$  and 0.4  $\mu\text{m}$  pore size [12]. Operated at an air sampling rate of 16 L/min the collecting device enables the separation of two size fractions of particulate matter dependent on their equivalent aerodynamic diameter, i.e. the coarse PM ( $2\ \mu\text{m} < \text{PM} < 10\ \mu\text{m}$ ) and the fine PM ( $< 2\ \mu\text{m}$ ). The sampler was positioned at the breathing height in the workplace and daily collections were accomplished for a period of 4 months. The aerosol collection was repeatedly done for 2min at 2h intervals for a 24h period (after total collection time of 30 min, clogging of the filters would occur), thus allowing a daily average exposure estimation.

### *2.1.3. Sample preparation and analytical methods*

PM and blood elemental concentrations were carried out by PIXE (Particle Induced X ray Emission) and INAA (Instrumental Neutron Activation Analysis) techniques [13, 14]. Experimental conditions and concentration calculation are described elsewhere [14, 15]. Filters were weighed for total collected aerosol mass determination and divided in two portions for elemental analysis purposes by INAA and PIXE analytical techniques. Concentrations were normalised for an 8h period of work.

For PIXE analysis, the blood samples (S, PBC, TB) were subjected to acid digestion with nitric acid and hydrogen peroxide, 15:1 v/v, together with Y as an internal standard in closed Teflon™ vessels (Parr® bombs for microwave digestion) as a pre-concentration procedure. For INAA the freeze-dried material is irradiated without pre-treatment.

### *2.1.4. PM characterization in the respiratory system*

The morphology and the elemental distribution and mapping of the airway epithelium, that allows the characterization of inhaled PM, was assessed from biopsy material using nuclear microscopy techniques installed at the ITN Van de Graaff accelerator. After excision, the samples were immediately frozen at  $-174^\circ\text{C}$  and sections with approximately  $10\ \mu\text{m}$  thick were produced in a cryostat. The sections are mounted on polycarbonate film and freeze-dried. Intermediate sections were stained to check for artefacts during sample handling.

The NMP set-up allows deriving different kinds of sample images whether using PIXE (Particle Induced X ray Emission) and RBS (Rutherford Backscattering Spectrometry) for elemental mapping, STIM (Scanning Transmission Ion Microscopy) for mass density variations or secondary electron image (SEM) for sample surface topography [16]. To obtain elemental distribution maps the sample area was scanned by means of a beam deflecting system and simultaneous PIXE, RBS and SEM analyses were performed. Analyses of points that correspond to an analysed area similar to the size of the beam [17] were carried out for regions of interest. For data acquisition, the OM-DAQ programme was used and quantitative micro-PIXE analysis was performed using the DAN32 programme [18].

### *2.1.5. Statistical analysis*

Blood and aerosol chemical element concentrations were first checked for normal distribution by Shapiro-Wilk W statistic (appropriated for samples with 50 or fewer observations) using initially the raw data and the natural logarithm transformed data. Mean, median and variance analyses were applied to blood elemental concentration and clinical data. Significant differences for the elemental and clinical data between and among the exposed and non-exposed groups of subjects were determined using non-parametric approaches (NP), such as,

Wald- Wolfowitz runs test (WW), Kolmogorov-Smirnov test (KS), Mann-Whitney U test (MW) and Kruskal Wallis one-way ANOVA (KW), besides the parametric Student t-test. All the comparisons assume that independent samples were originated from two different populations and differences were considered significant when the two-tailed confidence interval of 95% was exceeded at a probability error (p level) inferior to 0.05. The equality of variance assumption was verified using the F test or Levene test. Pearson correlation procedure and the equivalent Spearman non-parametric approximation were also applied. Whenever adequate ANOVA/MANOVA procedures were used to extract variability components between trace elements and clinical data to express exposure or living habits influence [19–21].

To characterize sources for PM at the workplace by establishing relationships between elemental concentrations for different PM size, frequency classes, correlation, regression analysis and discriminant procedures were applied to aerosol data. The classes or groups of samples for specific variables obtained can also be used in analysis of variance procedures, such as ANOVA/MANOVA to assess major components for PM variability at the work place [20, 21].

## **2.2. Quality Assurance**

Three different techniques, Energy Dispersive X ray Fluorescence (EDXRF), Total Reflection X ray Fluorescence (TXRF) and PIXE were used to initiate an evaluation programme on Quality Assurance (QA) procedures applied to X ray spectrometry for chemical analysis. The use of standard methodologies to assure the statistical control of measurement data was the main objective of this work. Certified Reference Materials were used and up to fifteen certified elements were analysed to carry out the QA procedures. For the internal quality control, z-scores were calculated and control charts and R (range) charts as recommended by ISO 8258 were produced [22–25] to summarise the repeatability of the analytical processes (Fig. 1).

a)

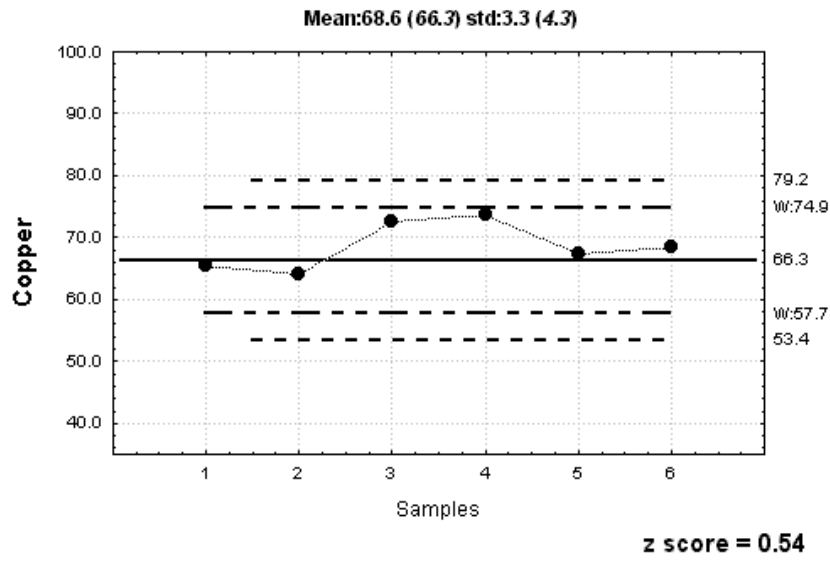

b)

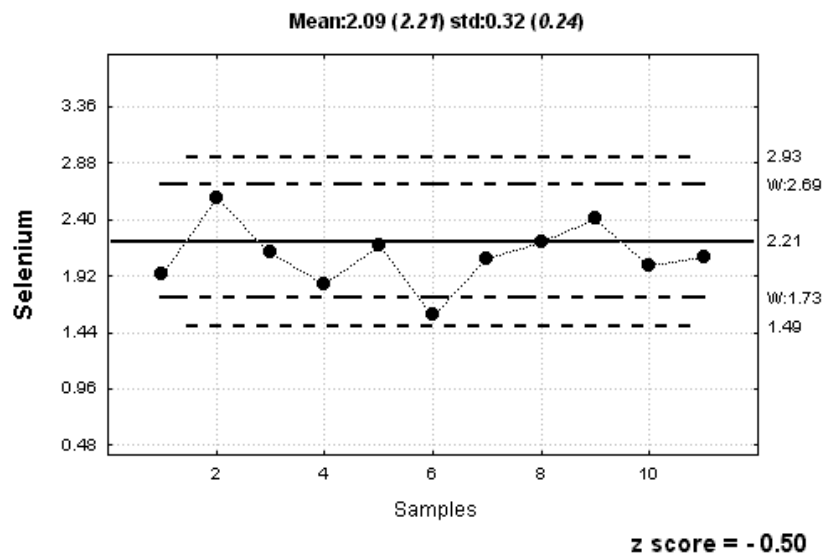

c)

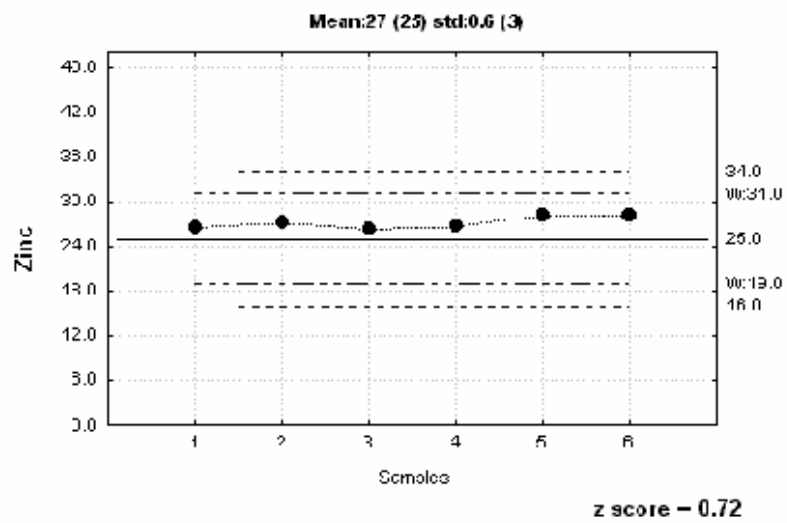



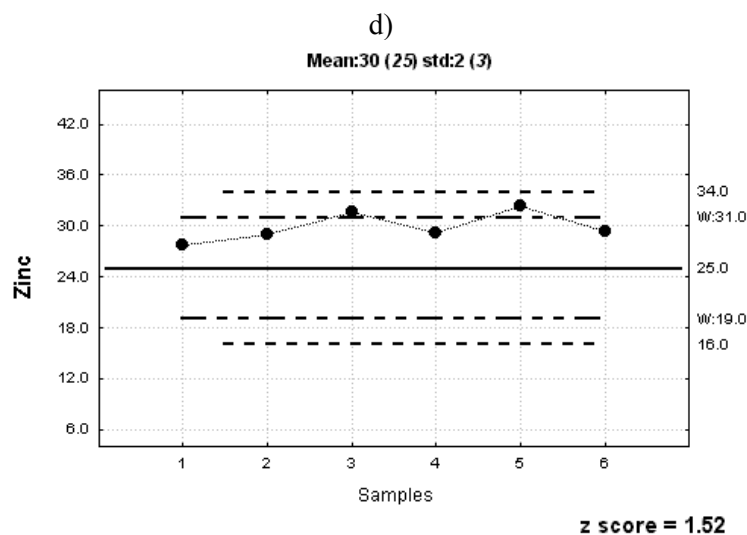

FIG. 1. Control charts for TXRF and PIXE content determinations of Cu (a) and PIXE content determinations of Se (b) in CRM NIST 1566a and of Zn by both techniques, c) TXRF and d) PIXE, in CRM NIST 1571, expressed in mg/kg. The full line represents the true value and the dashed lines indicate 2 sigma (warning limit, W) and 3 sigma limits. The mean and standard deviations (std) for the CRM material (in brackets) and for the various trials are indicated at the top of the figure. The z-score is also displayed.

The plotted elemental data illustrate statistically controlled methodologies for the majority of the determinations. Even the cases where the control charts exhibit values out of control limits, the z-scores are below three in absolute value, indicating satisfactory results. Elemental data plotted in control charts of Fig. 1a) and b) illustrate the statistically controlled methodologies and evidence the patterns of variation while in Fig 1c) positive bias of the Zn content is observed for PIXE Zn determination in CRM NIST1571. These variations give an insight for lack of statistical control permitting the search of uncertainty sources.

Concerning external quality control the statistical methods applied showed that the results obtained for the three techniques are comparable, although some significant differences occur, mainly due to sample preparation. For the external QC, student t-test, one-way ANOVA for unequal sample size and non-parametric Kruskal-Wallis (KW) procedures [20, 21], were used to check the normality of data distribution and variance homogeneity. The normality of data distribution and variance homogeneity was checked using Levene test. Post-hoc range tests and pairwise multiple comparisons (Scheffe and Tukey-B tests) were used to identify homogeneous subsets and significant differences of means. The inter-comparison of techniques evidenced significant differences for a few elements suggesting incomplete sample digestion in what concerns TXRF and PIXE analysis (Table I).

The preliminary evaluation programme on QA of EDXRF, TXRF and PIXE shows that methods are traceable to CRM's for a wide range of elements and enable the mathematical modelling of measurements and statistical control of methodologies. In addition, this programme initiated a database for the QA procedures and methodologies. The continuation of these studies is in progress aiming at the improvement of database in what concerns the number of trials for the CRM's used so far, as well as the widening to a broader range of certified reference materials.

TABLE I: PROBABILITY VALUES OBTAINED IN THE STATISTICAL TESTS APPLIED FOR THE THREE TECHNIQUE'S INTERCOMPARISON. THE PROBABILITY RESULTS ( $P < 0.05$ ) OBTAINED IN t-TEST FOR THE COMPARISON BETWEEN PAIRS OF TECHNIQUES, IN THE F TEST FOR THE ONE-WAY ANOVA AND IN THE CHI-SQUARE FOR KW, ARE DISPLAYED.

	NIST-1646				NIST-1571				NIST-1566a	
	Mn	Fe	Ni	Cu	Mn	Fe	Cu	Zn	Pb	Ni
t-test										
EDXRF-TXRF	0.023		0.000	0.001	0.000	0.001				
EDXRF – PIXE		0.020	0.004		0.000				0.002	
TXRF – PIXE							0.000	0.005		0.038
ANOVA										
One-way ANOVA	0.024	0.005	0.000	0.001	0.000		0.001	0.026	0.000	
Kruskal-Wallis	0.041	0.045	0.006	0.006	0.011		0.014	0.035	0.005	

### 2.3. Environment characterization

Up to 22 chemical elements were determined by PIXE and INAA techniques, i.e. Al, Si, P, S, Cl, K, Ca, Ti, Cr, Mn, Fe, Ni, Cu, Zn, As, Se, Br, Rb, Sr, Cd, Sb, Hg and Pb. The variability for the elemental concentrations is large (e.g. Cr, Mn, Fe, Cu, Zn, As, Cd, Sb, Hg and Pb). Some elements are characteristic of the coarse PM fraction ( $2 \mu\text{m} < \text{PM} < 10 \mu\text{m}$ ), such as, Si, Ca, and Fe, and others of the fine fraction ( $\text{PM} < 2 \mu\text{m}$ ), such as Hg. The concentrations measured are well below the limit values (LV) indicated in the Portuguese Normative Regulation [26]. However, the indicated LVs for exposure are relative to total particulate with a few exceptions, such as Si. Therefore, the comparison of results with the Portuguese normative reference is not applicable for most cases. In Table II some of the elemental concentrations obtained and the respective LVs are indicated.

The components of variance obtained from ANOVA/MANOVA procedures applied to the database suggest two major sources for the PM in the workplace. One of the components associates most of the major elements, such as, Al, Si, Ca, Mn, Fe, that are characteristic of the basic material, obtained from mineral reduction - coal, dolomite, limestone. The second component associates characteristic elements of scrap material that are added during steel processing, such as, Cu, Zn, Sb. For these elements significant correlation with Cd, Hg and Pb are then observed. Most probably, these elements exist in the scrap materials as impurities. The Hg variability only associates with Cu and Zn for the fine PM mode. Scrap material seem to constitute an important source of PM with high potential of toxicity due to the particle size ( $\text{PM} < 2 \mu\text{m}$ ) and to the chemical elements that associates, e.g. As, Cd, Hg, Pb.

TABLE II: MEDIAN CONCENTRATION VALUES IN  $\text{mg}/\text{m}^3$  (BASED ON N EVENTS FOR 72 CONSECUTIVE DAYS OF COLLECTION) FOR THE TWO PM FRACTIONS AND RESPECTIVE LVs.

	Median PM $<2\mu\text{m}$	Range (minimum – maximum)	Median 2 $\mu\text{m}$ <PM<10 $\mu\text{m}$	Range (minimum – maximum)	LV Total PM NP1796 [26]
Cu	$2.2 \times 10^{-4}$ (N=70)	$11 \times 10^{-6} - 1.4 \times 10^{-3}$	$2.6 \times 10^{-4}$ (N=72)	$54 \times 10^{-6} - 9 \times 10^{-3}$	1
Zn	$2.2 \times 10^{-3}$ (N=72)	$80 \times 10^{-6} - 0.28$	$4 \times 10^{-3}$ (N=74)	$133 \times 10^{-6} - 0.29$	5 (fumes) 10 (dust)
As	$13 \times 10^{-6}$ (N=28)	$1.6 \times 10^{-6} - 93 \times 10^{-6}$	$8.8 \times 10^{-6}$ (N=34)	$1.3 \times 10^{-6} - 200 \times 10^{-6}$	0.15 (arsenate)
Se	$6.8 \times 10^{-6}$ (N=7)	$0.5 \times 10^{-6} - 38 \times 10^{-6}$	$6.3 \times 10^{-6}$ (N=3)	$2 \times 10^{-6} - 10 \times 10^{-6}$	0.2
Sb	$6.1 \times 10^{-6}$ (N=42)	$0.8 \times 10^{-6} - 0.6 \times 10^{-3}$	$8.3 \times 10^{-6}$ (N=33)	$0.2 \times 10^{-6} - 0.4 \times 10^{-3}$	0.05
Cd	$43 \times 10^{-6}$ (N=11)	$1.4 \times 10^{-6} - 13 \times 10^{-3}$	$197 \times 10^{-6}$ (N=17)	$13 \times 10^{-6} - 6 \times 10^{-3}$	0.05
Hg	$8.5 \times 10^{-6}$ (N=19)	$0.7 \times 10^{-6} - 640 \times 10^{-6}$	$1.8 \times 10^{-6}$ (N=10)	$0.03 \times 10^{-6} - 23 \times 10^{-6}$	0.05
Pb	$1.7 \times 10^{-3}$ (N=51)	$0.14 \times 10^{-3} - 38 \times 10^{-3}$	$1.1 \times 10^{-3}$ (N=61)	$0.10 \times 10^{-3} - 38 \times 10^{-3}$	0.15

#### 2.4. Worker's health status

Seventy individuals working for more than 15 years at a steel processing sector were subjected to medical inspection. Respiratory affections (lung function alterations and radiographic opacities) were detected for 24% of the individuals surveyed and other 25% had significant opacities in the X ray examination observation.

The respiratory function decline seems to be dependent on both the number of years of work and smoking habits. An airway limitation was verified in the population studied according to the number of years of work (exposure to dust) (Fig. 2).

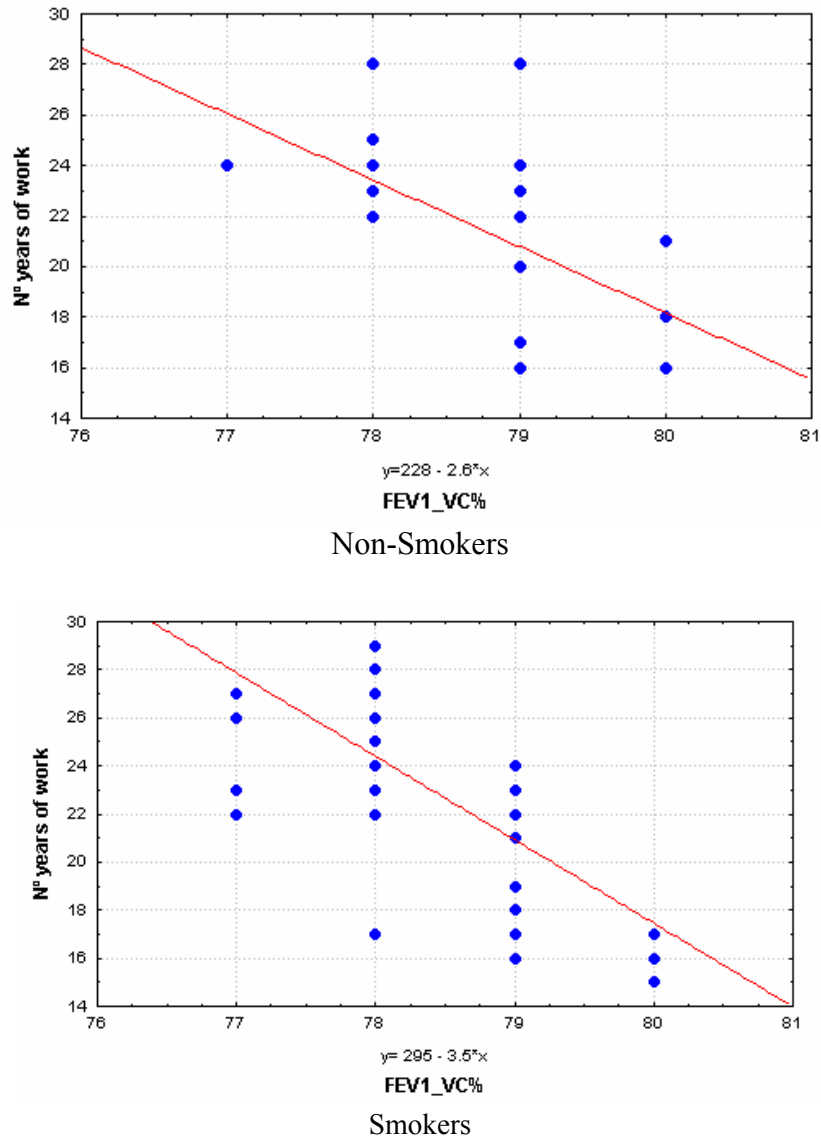

FIG. 2. Respiratory function and period of work for non-smoking and smoking groups. The regression line and equation are indicated.

Remarkably, smokers show a faster decline than non-smokers that can not be justified by average age or years of work (Table III).

TABLE III: AVERAGE AGE, YEARS OF WORK AND FEV<sub>1</sub> (%PRED) BASED ON N INDIVIDUALS, FOR THE ESTABLISHED GROUPS.

	Age average (min-max)		Years of work average (min-max)		FEV <sub>1</sub> (%pred)
non-smokers (N=24)	50	(40–55)	25	(17–29)	$90.8 \pm 12.7$
<30 pack-year (N=16)	47	(40–52)	21	(16–28)	$85.3 \pm 17.3$
>30 pack-year (N=7)	48	(41–54)	23	(16–28)	$78.8 \pm 14.8$
ex-smokers (N=24)	48	(39–54)	22	(15–29)	$91.1 \pm 11.7$

Nevertheless, an airflow capacity limitation expressed by the FEV<sub>1</sub> (in % of predicted value) can be observed for groups of smokers adjusted by packet-year for in (Fig. 3). In addition, obstructive patterns for lung function (obstructive and restrictive) associate with smoking groups (29% of smoking versus 9% of non-smoking individuals). As expected, for the group of ex-smokers the respiratory function returns to approximately the same level as non-smoking individuals [6].

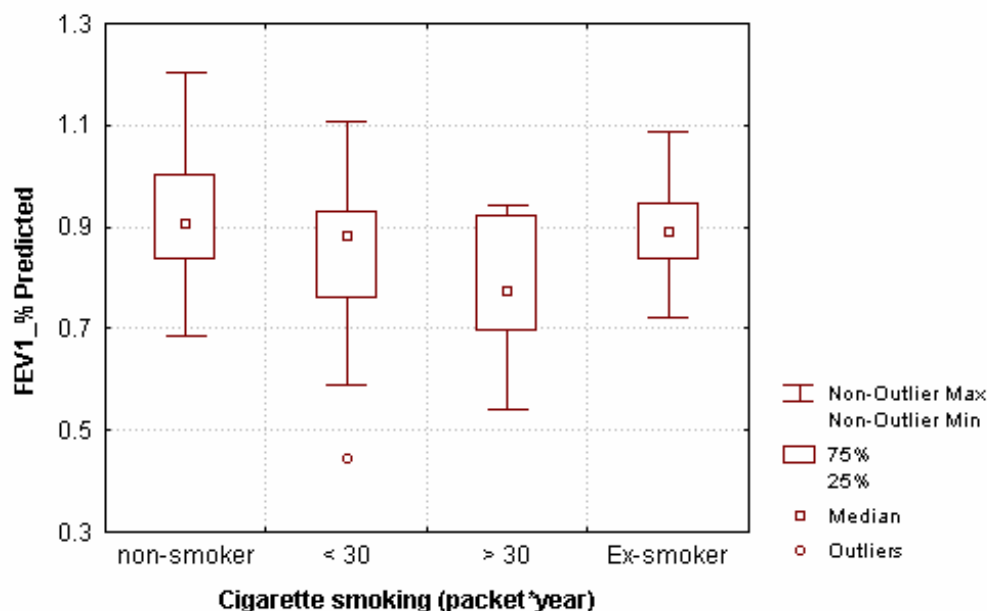

FIG. 3. Respiratory function, FEV<sub>1</sub>(%pred) variation according to smoking habits adjusted by packet-year.

However, some of the more preoccupying cases are not individuals suffering from larger exposures. Other risk factors in the population such as, pneumonia, allergy, etc, which are difficult to model due to the restricted population size may also play a role in the decline pattern of lung function.

## 2.5. Biomonitoring

For the population assessment with respect to long-term exposure effects, blood elemental concentrations were referred to the 90% coverage interval [11] calculated for a Portuguese reference group [9, 10].

Most of the exposed individuals exhibit serum Zn concentrations above the reference coverage intervals (exposed:  $1.24 \pm 0.44$  mg/L; reference interval: 0.71–1.00 mg/L) while most of the Se concentrations were below the lower reference limit (exposed:  $0.07 \pm 0.02$  mg/L; reference interval: 0.09–0.13 mg/L). For the PBC most of the Zn and Se values fell inside the coverage interval (reference intervals: Zn, 7.4–12.1 mg/kg and Se, 0.13–0.23 mg/kg, wet weight basis). The PBC Cu concentrations were in average higher than coverage intervals (exposed:  $1.14 \pm 0.23$  mg/kg; reference interval: 0.49–0.79), as can be observed in Fig. 4.

a)

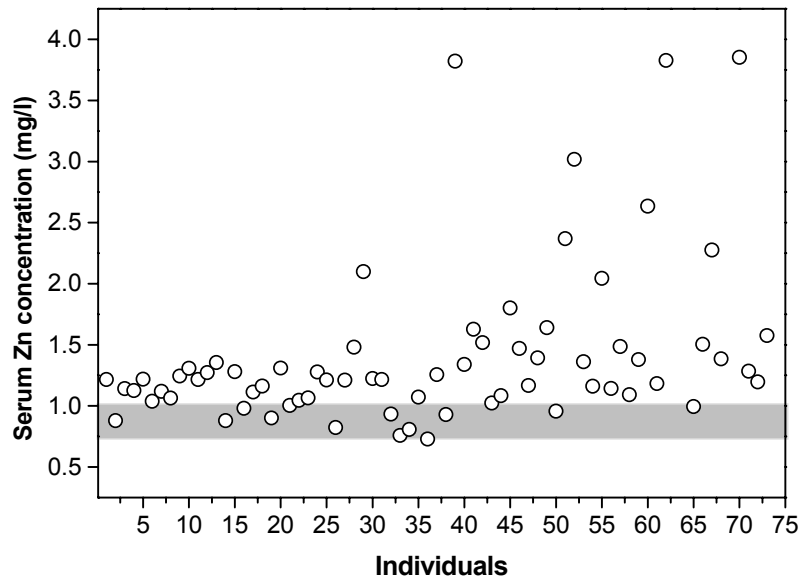

b)

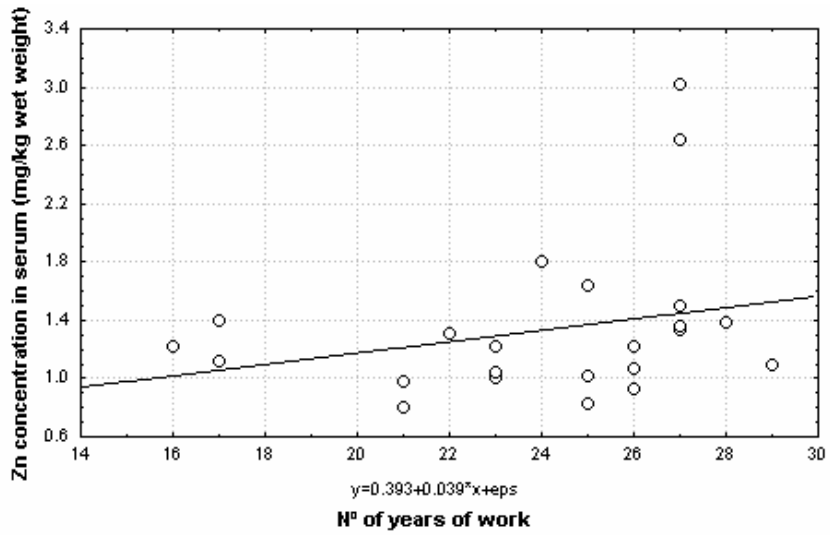

c)

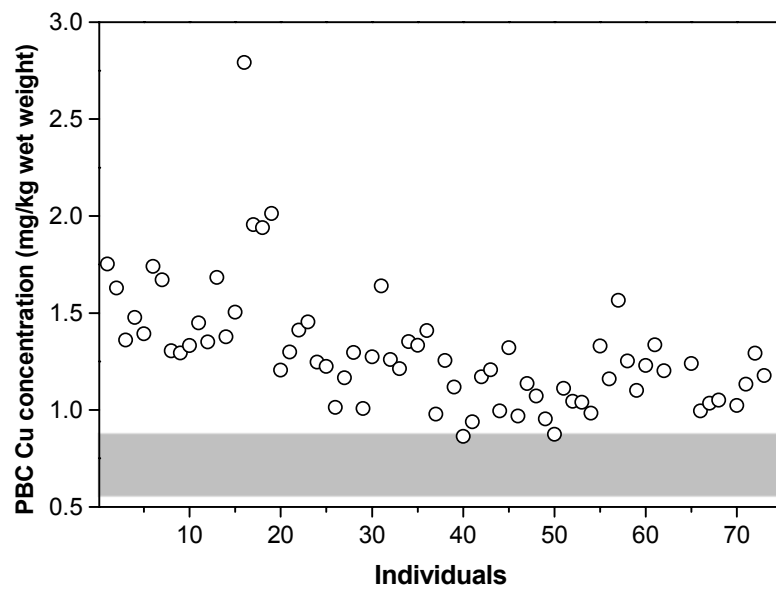

d)

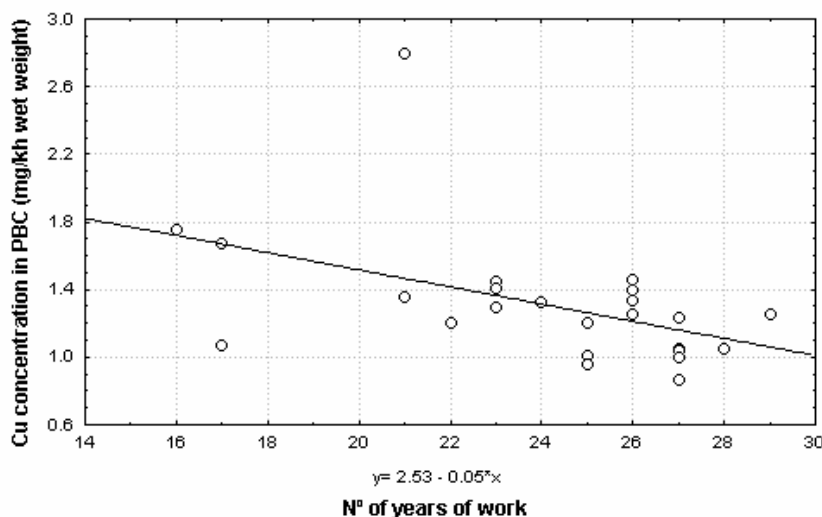

FIG. 4. Zn and Cu concentrations in blood a) and c) and their association with years of exposure b) and d). The grey areas in a) and c) graphics indicate the 90% coverage interval at a 95% confidence level (confidence uncertainty of  $0.90 \pm 0.09$ ) for a reference population of 80 non-exposed healthy individuals.

The increase of Zn serum levels associates with exposure duration. However, for Cu a negative relationship with exposure is verified despite the high PBC Cu levels (Fig. 4). Also, seric Fe is increased for the exposed population and the PBC fraction is depleted for this element. It is possible that the Fe decrease in the cellular blood fraction reflect the aging of the exposed group relative to controls and the increase of Fe and Zn in serum express exposure. It should be stressed that these elements exist permanently in the working environment and the quantities present in the inhalable and respirable fractions can not be overlooked.

The total blood Pb concentration is also high ( $0.45 \pm 0.32$  mg/L) with respect to reference limits (0.12–0.37 mg/L) and for one worker it exceeded the biological limit value (BLV) of 0.7 mg/l indicated in the Portuguese normative regulation.

To assess the influence of exposure and living habits in the health condition and in the elemental concentrations in blood a linear ANOVA model was used. The alterations detected for respiratory function and radiological examination (opacity degree) are associated with the exposure time and smoking habits, respectively. Blood Zn levels are also dependent on exposure ( $p < 0.05$ ). For the relationship of blood Se levels and exposure only a less significant probability ( $p < 0.06$ ) was found (Table IV).

TABLE IV: ANOVA RESULTS FOR TWO GROUPING VARIABLES (\*), EXPOSURE (NUMBER OF YEARS OF WORK) AND SMOKING ADJUSTED BY PACKET-YEAR. F VALUES AND PROBABILITIES ARE INDICATED FOR THE INDEPENDENT VARIABLES TAKEN INTO ACCOUNT IN THE MODEL (S — SERUM, TB — TOTAL BLOOD, PCB — PACKED BLOOD CELLS).

	F	p	F	p
Exposure (work-years) *	*		3.88	0.013
Smoking (packet-year) *	0.88	0.421	*	
FEV <sub>1</sub>	15.31	0.000	1.40	0.251
FEV <sub>1</sub> /VC%	64.69	0.000	3.13	0.031
FEV <sub>1</sub> (%Pred)	4.16	0.019	0.88	0.458
pulmonary obstruction (X-ray)	0.10	0.902	3.31	0.025
Hg (TB)	0.89	0.417	0.78	0.508
Zn (S)	5.13	0.009	0.24	0.864
Cu (PBC)	0.67	0.515	0.27	0.849
Pb (TB)	0.49	0.618	0.59	0.627
Se (S)	2.92	0.061	1.39	0.253

## 2.6. Particulate matter in the respiratory tissue

One of the major current issues is whether the toxicity of particles resides in some specific size or chemical form. The chemical characterization of major size fractions as currently being carried out (the PM<sub>10</sub> and PM<sub>2.5</sub>) show important geographical variations that do not reflect in exposure-response coefficient variation [4]. A linear relation between size of inhaled particles and acute respiratory symptoms is already verified at concentrations below 100 µg/m<sup>3</sup> [5].

The problem of particle size is difficult to assess due to scarcity of data. The adsorption of sub-micrometer size particles and cell stimulation seems to take place principally at distal regions of the respiratory system where gaseous exchange takes place [27] but there is little evidence that a specific chemical element of the particulate matter is responsible for the adverse effects. The intensification of cell reactivity (cytokine production, transcription factors, and various cell factors) is presumably a function of particle size decrease as suggested by *in vitro* studies [28]. Soluble metal concentrations in atmospheric dust may be a crucial factor in determining pulmonary reactivity. *In vitro* studies link the content of metal salts in particulate matter mixtures to inflammation, epithelial cell proliferation, fibrosis, and cell necrosis. One of the aspects that may contribute to the perception of particle-epithelial cell interaction in the respiratory tract is the eventual diffusion or fate of their chemical constituents. The elemental distributions and accumulation patterns for toxic and essential elements at different levels of the respiratory system may be due to different mechanisms for removal, providing some information about the toxicity of particulate matter and evidence for mobilisation processes of toxic elements.

The work carried out tries to give a contribution to the characterization of agglomeration sites for inhaled particulate matter from the standpoint of particle removal mechanisms and diffusion of their elemental constituents into adjacent cellular environments, using nuclear microprobe techniques. Single particles were identified at tracheal mucosa with average typical diameters of 10 µm. At bronchial mucosa and epithelial layers, single particle deposits were significantly smaller in diameter (2–3 µm) than in trachea [29] (Fig. 5).



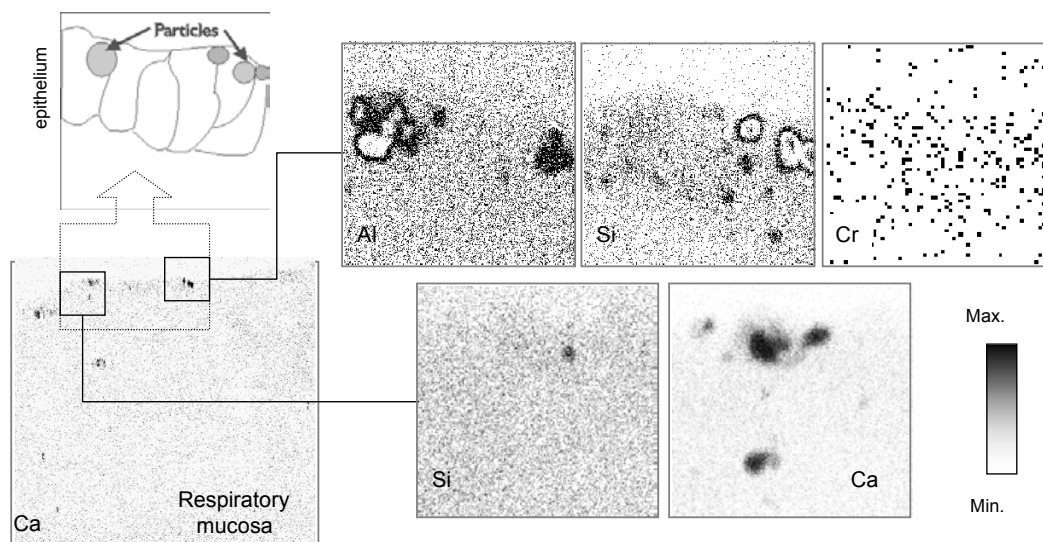

FIG. 5. Elemental maps of the trachea respiratory mucosa. A simplified schematic of the scanned areas ( $50 \times 50 \mu\text{m}$ ) identified in the Ca distribution map of a larger scan ( $500 \times 500 \mu\text{m}$ ) show the cellular environment where particles can be visualised.

Large numbers of granulocytes were identified at these regions (sub-epithelial layers) as well as in distal parts of the respiratory tree. Significant particle deposits were found at distal respiratory tract. Al, Si, Ti, V, Cr, Fe, Ni, Cu and Zn are elements detected at these accumulation areas (Fig 6).

The elemental distributions in the different cellular environments of lymph nodes vary. The major compartments for Al, Si, Ti, Fe and Cr are the phagocytic cells and capsule of lymph nodes, while V and Ni are in the cortex and paracortex medullar areas which retain more than 70% of these two elements, suggesting high solubility of the latter in the cellular milieu.

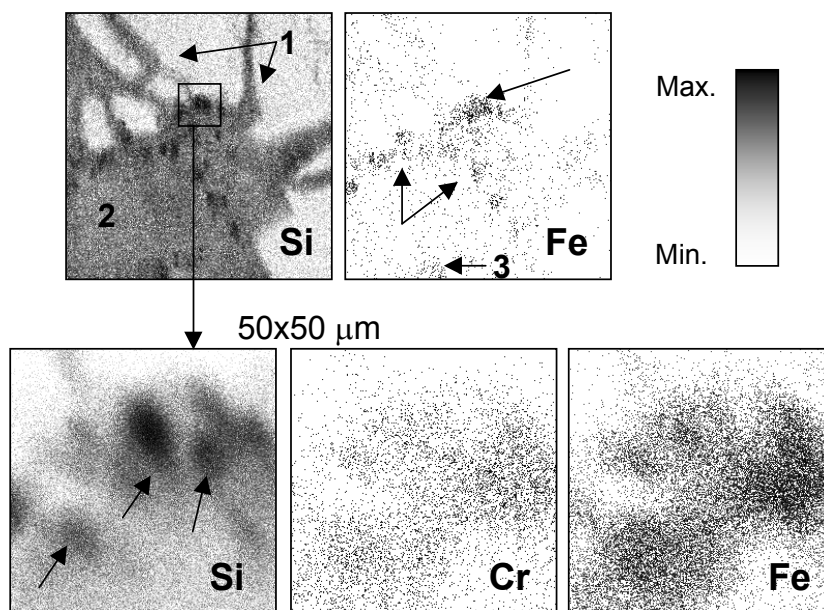

FIG. 6. Elemental maps for alveolar region of the respiratory tract (500x500  $\mu\text{m}$ ). At the Si distribution map alveolar cavities (1) and alveolar walls (2) are indicated and at the Fe distribution maps a granulocyte cell is visible (3). The arrows at the Fe map indicate particle deposits. A detailed view of the alveolar walls deposits (arrows at the Si map) can be observed by the Si, Cr and Fe maps below.

The elemental mobilisation from particles or deposits to surrounding tissues at the respiratory ducts evidence patterns of diffusion and removal that are different than those for elements in the respiratory tract. Mobilisation of elements such as V, Cr, and Ni is more relevant at alveoli areas where gaseous exchange takes place [30]. The apparent high solubility of V and Ni in the respiratory tract tissue point towards a deviation of the lymphatic system filtering efficiency for these elements when compared to others (Fig.7).

The differences encountered in the composition of inhaled particles may be related with their origin and size (natural or anthropogenic). In fine particulate matter, V, Ni and Zn are frequently associated to sulphates [27] resulting in highly soluble compounds which may be a crucial factor in determining cell reactivity and responsiveness to inhaled particulate. The high frequency of particles or agglomerates of particles containing V, Cr, Ni and Zn at deeper regions of the respiratory tract is compatible with data obtained for direct characterization of fine particulate and for studies carried out with animal models [28].

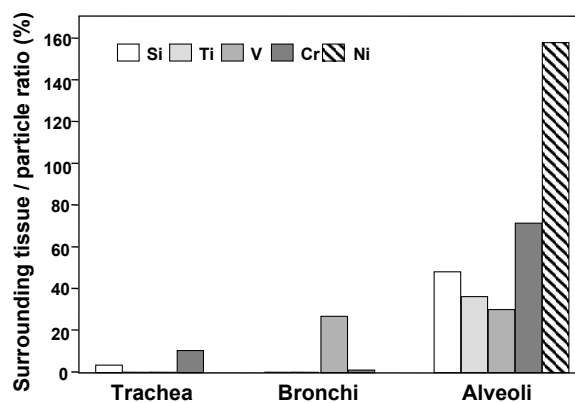

FIG. 7. Particle Si, Ti, V, Cr and Ni constituents mobilisation in surrounding tissue.

In an animal model study carried out with rats (Sprague-Dawley) exposed to the work atmosphere during the period of PM collection higher contents of Cr, Mn, Fe, Ni, Cu, Zn and Pb were observed in the trachea and bronchi relative to controls. Cr was only detected for exposed animals ( $1.25 \pm 0.54$  and  $0.93 \pm 0.02$  mg/kg dry weight, in trachea and lung, respectively). The higher Cr levels found in trachea, relative to lung, is in agreement with the preferential Cr distribution within the PM<sub>10</sub> size-fraction. However, the larger concentrations of Mn and Fe encountered in lungs of exposed rats (exposed: Mn,  $14.7 \pm 5.6$  and Fe,  $1640 \pm 590$ , control: Mn,  $0.87 \pm 0.21$  and Fe,  $760 \pm 110$ , in mg/kg dry weight) relative to trachea (exposed: Mn,  $1.72 \pm 0.61$  and Fe,  $350 \pm 157$ , control: Mn,  $0.88 \pm 0.19$  and Fe,  $340 \pm 145$ , in mg/kg dry weight) can not be justified by the aerosol predominant size fraction.

As for the elemental distribution found in the rat respiratory system the elemental diffusion patterns inferred for the human respiratory system, suggest that other mechanisms than PM aerodynamic size, may rule the penetration and/or removal of PM in the respiratory mucosa.

### 3. CONCLUDING REMARKS

Marked respiratory affections inferred from lung function alterations and radiographic opacities, were detected for 24% of the subjects surveyed working for more than 15 years at a steel processing sector. Apart from the airways limitation derived from smoking, the respiratory function decline is dependent on the number of years of work. A significant relationship between serum altered concentrations of Zn (enhanced) and Se (decreased) relative to a reference population and PM exposure at the workplace was found. Also, enhanced Cu concentration in PBC blood fraction and elevated Pb and Hg levels in total blood of workers relative to reference group can be associated to exposure. Thus, alterations found in blood elemental contents, can be associated to the dust Cu, Zn, Pb and Hg contents in both PM<sub>10</sub> and PM<sub>2.5</sub>.

The elemental distribution of characterization of the respiratory mucosas and associated lymphoid tissues suggest an important mobilisation of the elemental constituents of inhaled PM into the adjacent tissues. The diffusion of elements from particles at distal regions of the respiratory system with a special emphasis to V, Cr and Ni seems to be more important than at upper regions of the respiratory tree, where other elements, such as Al, Si, Ti, are predominant and associate with larger particles. The results obtained suggest high permanence of specific elements in the respiratory system due to their chemical affinities for

biological components or impaired phagocytosis due to their association with smaller particles, as proposed by Renwick et al. [31]. Thus, further studies on the elemental distributions in respiratory mucosae and gaseous exchange areas of the lung are mandatory to evaluate diffusion rates of chemical elements and the relation with the molecular mechanisms triggered by them.

As far as biological monitoring to assess exposure influence is concerned, extended studies would be required to evaluate the physiological status of exposed subjects. Both elemental concentrations and biochemical indicators in various body fluids (blood, urine, sputum) would be beneficial and should be included in future studies to better assess the response of biological systems exposed to airborne particulate matter.

## REFERENCES

- [1] SCHWARTZ, J., Is There Harvesting in the Association of Airborne Particles with Daily Deaths and Hospital Admissions? *Epidemiology* **12** (2001) 55.
- [2] OSTRO, B., et al., Air Pollution and Exacerbation of Asthma in African-American Children in Los Angeles, *Epidemiology* **12** (2001) 200.
- [3] HAGEN, J.A., et al., Associations between outdoor air pollutants and hospitalization for respiratory diseases, *Epidemiology* **11** (2000) 136.
- [4] HARRISON, R.M., YIN, J., Particulate matter in the atmosphere: which particle properties are important for its effects on health, *Sci. Total Environ.* **249** (2000) 85.
- [5] SCHWELA D., Air pollution and health in urban areas, *Rev. Environ. Health* **15** (2000) 13.
- [6] HOSHINO, Y., et al., Airflow limitation in Japanese smokers: significance of serum neutrophil elastase/alpha (1)-proteinase inhibitor ratio and FEV(1) (%pred) adjusted by pack-years, *Respiration* **67** (2000) 372.
- [7] International Classification of Radiographs of the Pneumoconioses, ILO-80, International Labour Office, Geneva (1980).
- [8] PINHEIRO, T., et al., Applicability of microwave acid digestion to sample preparation of biological materials for analysis of Particle Induced X ray Emission (PIXE), *Biol. Trace Elem. Res.* **26/27** (1990) 589.
- [9] PINHEIRO, T., et al., Trace elements in human blood: alterations associated with myocardial infarction, *Int. J. PIXE* **2** (1992) 469.
- [10] VIEGAS-CRESPO, A.M., et al., Trace Element Status (Se,Cu,Zn) and Serum Lipid Profile in Portuguese Subjects of S. Miguel Island from Azores' Archipelago, *J Trace Elem Med Biol* **14** (2000) 1–5.
- [11] POULSEN, O.M., et al., Calculation and application of coverage intervals for biological reference values (Technical Report), Commission on Toxicology, Pure & Appl. Chem. **69** (1997) 1601.
- [12] MAENHAUT, W., et al., Applied research on air pollution using nuclear-related analytical techniques, IAEA-NAHRES-19, Vienna (1994).
- [13] INTERNATIONAL ATOMIC ENERGY AGENCY, Instrumentation for PIXE and RBS, IAEA-TECDOC-1190, Vienna (2000).
- [14] FREITAS, M.C., MARTINHO, E., Accuracy and precision in instrumental neutron activation analysis of reference materials and lake sediments, *Anal. Chim. Acta* **223** (1989) 287.
- [15] ALVES L.C., et al., Air particulate matter characterization of a rural area in Portugal, *Nucl. Instr. and Meth.* **B136-138** (1998) 941.

- [16] ALVES L.C., et al., Micron-scale analysis of SiC/SiCf composites using the new Lisbon Nuclear Microprobe, Nucl. Instr. and Meth. **B161-163** (2000) 334.
- [17] GRIME, G.W., DAWSON, M., Nucl. Instr. and Meth. **B104** (1995) 107.
- [18] GRIME G.W., Nucl. Instr. and Meth. **B109/110** (1996) 170.
- [19] WOOLSON, R.F., Statistical Methods for the Analysis of Biomedical Data. John Wiley & Sons, New York (1987).
- [20] NORUSIS, M.J., SPSS for Windows Release 8.0, User's Guide. Inc. Chicago (1999).
- [21] STATISTICA<sup>®</sup>, User Manual, Release 5, 3<sup>rd</sup> Ed., StatSoft Inc., Tulsa (1997).
- [22] International Organisation for Standardisation, Guide to the Expression of Uncertainty in Measurement (GUM). ISO, Geneva (1995).
- [23] International Organisation for Standardisation, ISO Standard 5725, Accuracy (trueness and precision) of Measurement Methods and Results. ISO, Geneva (1994).
- [24] International Organisation for Standardisation, ISO Standard 8258, Shewhart Control Charts. ISO, Geneva (1991).
- [25] MASSART, D.L., et al., Chemometrics: a textbook. Elsevier, Amsterdam (1988).
- [26] Norma Portuguesa NP1796 o nivel admissivel de concentracao para o gas, Instituto Português da Qualidade (1988).
- [27] JIMENEZ, L.A., et al., Activation of NF-kappaB by PM(10) occurs via an iron-mediated mechanism in the absence of IkappaB degradation, Toxicol. Appl. Pharmacol. **166** (2000) 101.
- [28] ADAMSON, I.Y., et al., Zinc is the toxic factor in the lung response to an atmospheric particulate sample, Toxicol. Appl. Pharmacol. **166** (2000) 111.
- [29] PINHEIRO, T., et al., Airborne Particulate Matter Localisation in the Human Respiratory System, Nucl. Instr. and Meth. **B158** (1999) 499.
- [30] PINHEIRO, T., et al., Mobilisation of Toxic Elements in the Human Respiratory System Nucl. Instr. Meth. **181**(1-4) (2001) 499–505.
- [31] RENWICK, L.C., et al., Impairment of Alveolar Macrophage Phagocytosis by Ultrafine Particles, Toxicol. Appl. Pharmacol. **172** (2001) 119.

# WORKPLACE MONITORING AND OCCUPATIONAL HEALTH STUDIES AT THE CENTRE FOR PRODUCTION OF PHOSPHORUS MINERAL FERTILIZERS, VOSKRESENSK (MOSCOW REGION, RUSSIAN FEDERATION), USING NUCLEAR AND RELATED ANALYTICAL TECHNIQUES

S.M. LYAPUNOV<sup>1</sup>, M.V. FRONTASYEVA<sup>2</sup>

<sup>1</sup> Institute of Geology of RAS, Moscow, Russian Federation

<sup>2</sup> Institute for Nuclear Research, Moscow Region, Russian Federation

## Abstract

The phosphate fertilizer production has a pathological impact on its occupational staff causing *fluorosis*, respiratory and other diseases. Nuclear and related analytical techniques such as NAA, AAS, and XRF were used to establish correlation between the concentrations of elemental pollutants in raw materials, byproducts, humans, and the workplace. This, in turn, allowed us to determine how man's biosubstrates can be used to follow the rate of pathological changes in the organism as it is being exposed to intense technogenic environments. For the first time an attempt was made to elucidate the problem Phosphate Fertilizer — Occupational Health. The most typical associations of element-pollutants in the shops and premises of the «Mineral Fertilizer» plant in Voskresensk, Russian Federation, were revealed while monitoring the workplace. The monitoring strategy developed in our study for this kind of industry in Russia is offered for dissemination at similar fertilizer plants in any part of the world.

## 1. INTRODUCTION

### 1.1. Objectives

During the past decade, the global fertilizer industry has made substantial progress in the identification and mitigation of potential environmental impacts that may occur at the point of production and throughout the physical distribution system. However, very few have been done to enlighten the problem of the occupational health affected by the hazardous impact of this industry which causes *fluorosis*, respiratory and other diseases.

The present report reviews the experience obtained while monitoring one of the biggest world's phosphate fertilizer plants in the Russian Federation to reach the main goal of the project: how man's biosubstrates can be used to follow the rate of the pathological changes in the organism as it is exposed to intense technogenic impact. The objectives of the project were as follows:

- to evaluate current knowledge on elemental pollutants (F, Cr, Cu, Zn, As, Se, Sr, Sb, rare-earth elements (REE), Th, U, and others) in raw materials, byproducts, and human biosubstrates at phosphate fertilizer plant;
- to determine the content and level of air pollution of the working areas and the drinking water at selected shops of the examined phosphate fertilizer plant;
- to determine the contamination level of soil and vegetation growing at the premises of the relevant plant;
- to determine the normal and abnormal concentrations of elements in biosubstrates (hair, urine, nails, teeth) of the occupational staff;

- to determine the correlation between the pathological changes in the organism and elemental concentrations in biosubstrates;
- to develop a strategy for scientifically based monitoring system for phosphate fertilizer plants.

Two accredited analytical laboratories (in Moscow and in Dubna) were involved in the project. Both of them have long experience in using the analytical techniques in question. To provide statistically reliable data on toxic elemental content in the examined media, 525 (environmental and biosubstrates) samples in total were collected for the analysis. Quality assurance of the results obtained was provided by participating in IAEA intercomparisons (NAT-3 through 7). Thus, the new knowledge on phosphate fertilizer production impact on occupational health can be incorporated in the world-accepted monitoring system developed for hazardous industries.

## 1.2. Innovation

Phosphate fertilizers impact is usually determined by studying the amount of sulphur and nitrogen compounds and fluorine in the air. Individual elements have been studied in many countries. In the early 1980s, specialists of the Institute of Mineralogy, Geochemistry and Crystallochemistry of RAS used emission spectrometry to provisionally study of the geochemistry of soil and snow around fertilizer plant in Voskresensk (Moscow Region) and Apatity (Kola Peninsula). This study revealed another, previously unknown, type of depositional pollution: increased REE, zinc, and strontium [1]. In the early 1990s, the Institute of Environmental and Biological Sciences, Lancaster University, UK, used AAS to study how phosphate fertilizer affects long-term concentration of cadmium in crops and soils [2]. The University of Illinois has published a set of papers on natural radioactivity and heavy metals in phosphate fertilizer [3]. Chinese scientists noted the role of the REE in increasing crop capacity due to the disposal of phosphogypsum – one of the main industrial wastes of phosphorus mineral fertilizer production — in its agricultural use as an ameliorant.

Investigation [1] (*A Comparative Analysis of the Industrial Impact on the Environment*) stimulated further studies [4–6] in 1985-1989 by GIN RAS and JINR (the authors of the project) at the same «Mineral Fertilizer» plant in the town of Voskresensk, using more precise methods of X ray fluorescence (XRF) and neutron activation analyses (NAA). The main anthropogenic streams blown into the air, which then fall back to the earth's surface (soil, snow), as well as their uptake into agricultural plants nearby and into humans, were investigated. The impact of technogenic flows on man's organism was examined by comparing the concentrations and associations of various elements in hair from relatively normal and impacted subjects [7].

The presence of rare earth elements (REE) in significant amounts in biosubstrates shows that they play a special role and participate in biological cycles of growth. In this project, the epithermal NAA (with radiochemical separation when necessary) was used to study the character of the REE distribution in human biosubstrates. This technique is made possible by the pulsed fast reactor used in Russia and its high fluxes of epithermal and fast neutrons, which allows one to determine the REE, with their large resonance integrals, more sensitively and precisely than with conventional thermal NAA.

From the previous experience of the authors of the project, it follows that fluorine, strontium and rare earth elements produce the most intense impact on the occupational staff. Therefore, one of the priority tasks of the project was to investigate fluorine distribution in biosubstrates of man.

By monitoring the workplace at the above mentioned plant and connecting the results with occupational health studies, the relationship between elemental pollutants (Cr, Cu, Zn, As, Se, Sr, Sb, REE, Th, U, and others) from the raw phosphate material and manufacturing byproducts in air, drinking water, industrial dust and in human biosubstrates (hair, nails, bone-tissue — teeth) was established. To the best of knowledge of the authors of this project no other scientific group has studied such large associations of elemental pollutants from fertilizer plants and their effects on human health. The authors also are not aware of any analogous programmes in the Western countries.

For the first time, the sanitary-hygienic situation at the phosphate fertilizer plants was evaluated from objective knowledge of workplace pollution and its effect on biosubstrates of occupational staff, on one hand, and on the results of medical diagnostic tests, on the other hand. The principle scheme of the interrelationship between eco-geochemical studies and medical-biological studies is given in Fig. 1.

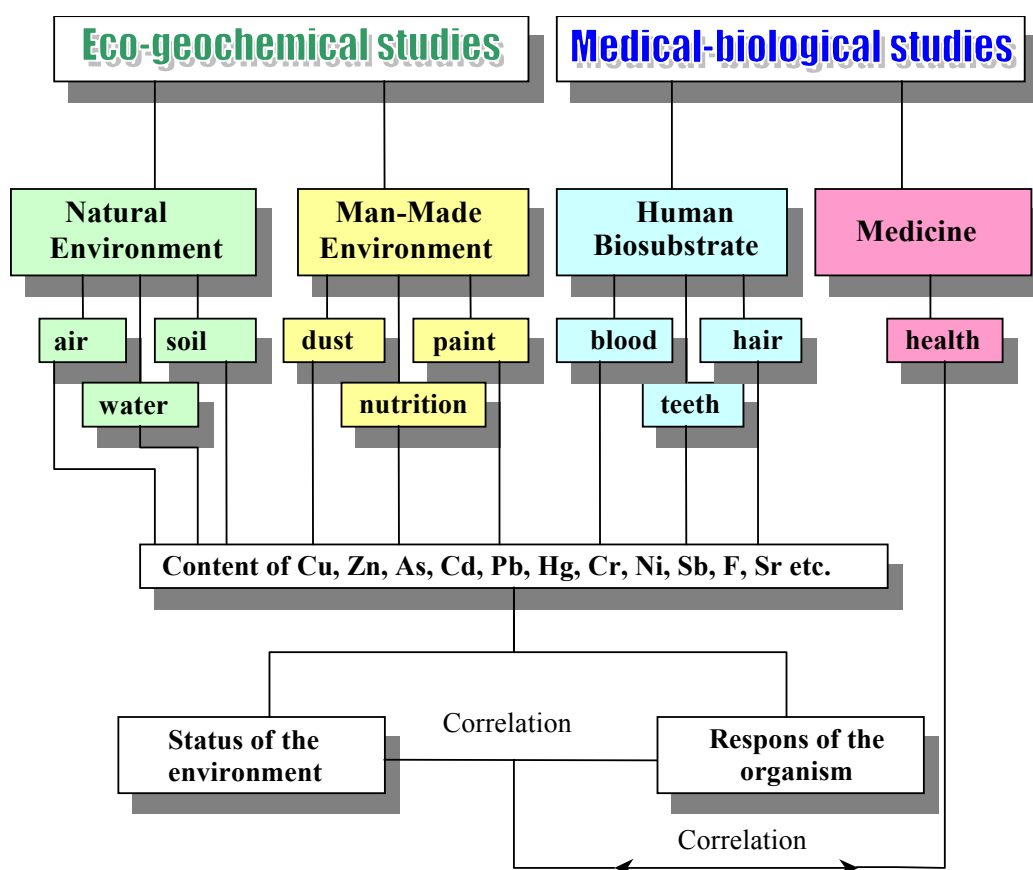

FIG. 1. The interrelationship between eco-geochemical and medical-biological studies.



### 1.3. Community added value and contribution to EU policies

The phosphate fertilizer plants in Europe, Asia and America use different types of phosphate ores which are characterized by specific elemental content. Apathite ores are rich in strontium (up to 1–2%) and in rare earth elements (REE), up to 1%. Phosphorites contain elevated concentrations of uranium and thorium (up to 0.1–0.5%), fluorine, arsenic and heavy metals. While ores reprocessing, these and other toxic elements through air and other media may affect environment and health of the occupational staff and local residents causing *fluorosis*, respiratory and other diseases. High concentrations of thorium and uranium induce unfavourable radiological situation at the plants and adjacent territories. Russia possesses tremendous deposits of ores for phosphate fertilizer industry and exports it to many countries, whereas Eastern Europe and the European Community are mostly based on imported raw material for this kind of industry. Foreseen economical integration in the XXI century requires inter-exchange of advanced reprocessing technologies and reduction of negative impact of hazardous industries on human health and occupational health, in particular.

## 2. EXPERIMENTAL

### 2.1. Sampling and sample preparation

#### 2.1.1. Atmospheric deposition study

To assess the distribution of pollutants in airflows in the vicinity of the acting emission source, snow as a depositing medium has been used. The snow sampling is significantly cheaper and less labor consuming than the collecting of atmospheric aerosols by means of impactors. The snow sampling, besides, gives an integral picture of atmospheric pollution levels for the period of permanent snow cover in winter months, and it is considered one of the most contrast and complete sources of information characterizing both the aerosol and gaseous components of atmospheric pollution. The snow sampling was carried out in accordance with the wind-rose from the seven experimental sites along the 15 km profile as described in [8] (Fig.2).

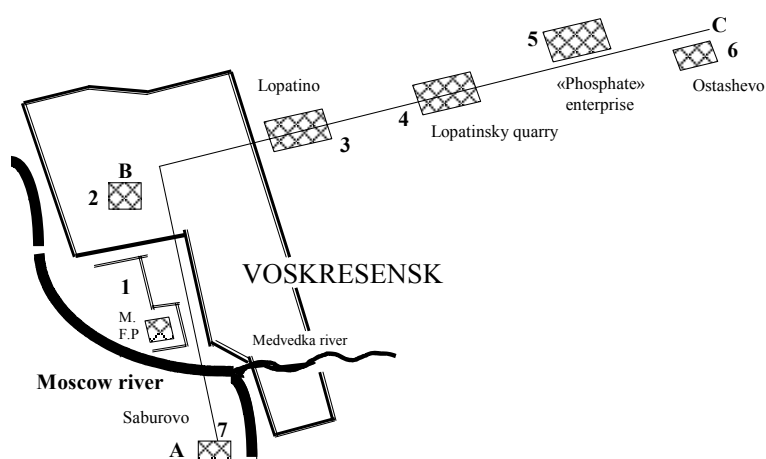

FIG. 2. The position of the experimental sites along the profile A-B-C, relatively to the source of the emissions, «Mineral Fertilizer» plant (1).

The volume of the snow core was fixed. The samples were packed in double polyethylene bags and brought to the laboratory for the further processing: melting at room temperature, filtration of all amount of snow through a dense filter, drying and weighing the non-dissolved residual on the filter. Filters with the non-dissolved residual and liquid filtrate were subjected to cation-anion analysis.

### 2.1.2. Air of the working area

Air of the working area and pollution streams (dust) blown into the air were collected in the shops of oleum phosphate extraction (OPE-1, 3, 4), ammonium phosphate fertilizers production (AMM-1, 2), oleum sulphate extraction (OSE-3) and in the Central laboratory of the plant (CL). Allocation of the main shops under consideration on the premises of the plant is shown in Fig. 3.

Samples were collected in the places of permanent or long-term work of the occupational staff. To determine fluorine in air samples, a technique based on babbling process was used. To collect aerosols on filters (AFA-XA-20, Russia), the electric aspirators (model 822 and AC-1, Russia) were used continuously during the working time (6–8 hours) to pump around 0.6–5 m<sup>3</sup>.

### 2.1.3. Industrial raw material and byproducts

From 1989 to 1993, the plant was rebuilt to more efficiently utilize phosphogypsum ( $\text{CaSO}_4 \cdot 2\text{H}_2\text{O} + 0.6\text{--}1.0\% \text{P}_2\text{O}_5$ ). As a result of the oleum sulphate extraction process (the most common one in the production of phosphorus fertilizer), approximately 5 t of phosphogypsum are precipitated per 1 t of final product (ammophos, or ammonium phosphate: 47–60%  $\text{P}_2\text{O}_5$ , 11–13% N, 1–2% Ca). There are several ways of disposing of phosphogypsum: to use it as an agricultural meliorant, as a building material (tile, filling and binding components), etc. Practically all of the methods of phosphogypsum disposal were developed without taking into account the increase in pollution levels caused by element-impurities in the phosphate raw material.

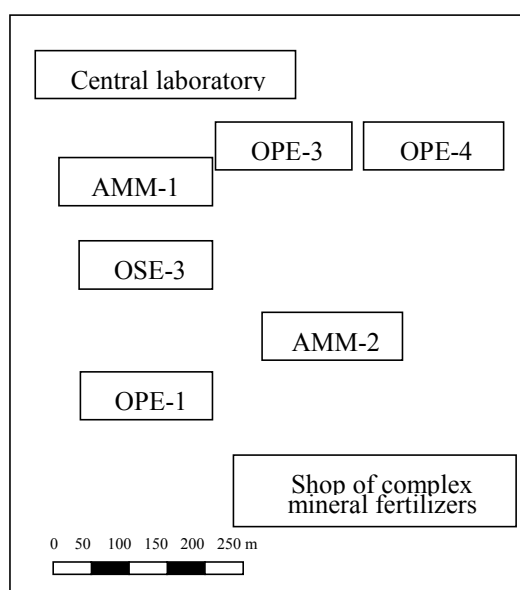

FIG. 3. «Mineral Fertilizer» plant premises.

For this and other objective reasons, the by-product goods did not find a market, and the shop for reprocessing the main disposal waste (phosphogypsum) was shut down.

The production of complex mineral fertilizers were shut down also, as well as the production of oleum phosphate in one of the shops, specifically, OPS-2. In addition, the technology of oleum sulfate extraction was changed. These activities must have altered the environmental situation in and around the plant, and, in turn, its effects on humans. To estimate the most probable sources of the air pollution in the working area, samples of the main type of industrial raw material (apatite concentrate), the final product (ammophos), and its byproducts (phosphogypsum and compost) were collected. The present-day products of the «Mineral Fertilizer» plant in Voskresensk are summarized in Table I. Their elemental composition is given in Table II.

TABLE I: PRESENT-DAY PRODUCTION AND ELEMENT ASSOCIATIONS MOST TYPICAL FOR THE RELEVANT SHOPS OF THE «MINERAL FERTILIZER» PLANT IN VOSKRESENSK

No.	Type of production	Shop	Association of chemical elements
1	Oleum phosphate extraction	OPS-1, OPS-3, OPS-4	F, Sr, Zn, REE
2	Ammonium phosphate fertilizers	AMM-1, AMM-2	F, Sr, REE
3	Oleum sulphate extraction	OSE-3	Sr

TABLE II: ELEMENTAL COMPOSITION OF RAW MATERIAL, FINAL PRODUCT AND BYPRODUCT

Type	%				mg/kg										
	F	P <sub>2</sub> O <sub>5</sub>	Ca	Sr	La	Ce	Th	U	Cr	Sb	Cu	Zn	As	Pb	
Raw material (apatite concentrate)	2.3	40.7	30	2.0	1900	3000	23	9.4	<5	8.7	100	70	1.0	1.2	
Final product (ammophos)		65	1.5	0.04	110	210	12	<5	<5	<1	50	50	<0.1	<1	
Byproducts Phosphogypsum	0.14	1.4	19	1.4	1000	1400	6,0	10	28	<1	<20	<10	<0.1	1.0	
Compost	<0.01	-	18	0.14	40	65	3.1	3.0	320	8.6	650	510	21	50	

#### 2.1.4. Soil

The technogenic anomalies in soil, as usual are sufficiently less intensive than in the atmospheric air or in the snow cover. Nevertheless the soil contamination is an important characteristics of the plant emissions assuming its many-year technogenic impact. Soil samples of the upper (0–3)–(0–10) cm humus horizon were collected in the central and eastern parts of the territory in accordance with norms and standards accepted in the Russian Federation and US EPA [9–10].

### 2.1.5. Industrial sewage, water, bottom sediments

The industrial sewage is a hazardous source of pollution of natural water resources. The sewage emission of the plant could be subdivided into conditionally clean, economic-everyday (domestic) and chemically polluted. The conditionally clean waters, i.e. 80% of all sewage emissions, are thrown directly into the Moscow River through the western and central collectors. The economic-everyday (domestic) and chemically polluted sewage are passing to the sewage tanks. They are neutralized as well. Water samples were taken directly from the collector and from the Moscow River, upstream and downstream of it. The whole procedure: sample collecting, conservation of water and its storage — were in accordance with norms and standards approved in the Russian Federation [11–12]. Bottom sediments were collected along the banks of the river at the depth of 1–1.5 m with a step of 500 m (See Fig. 4).

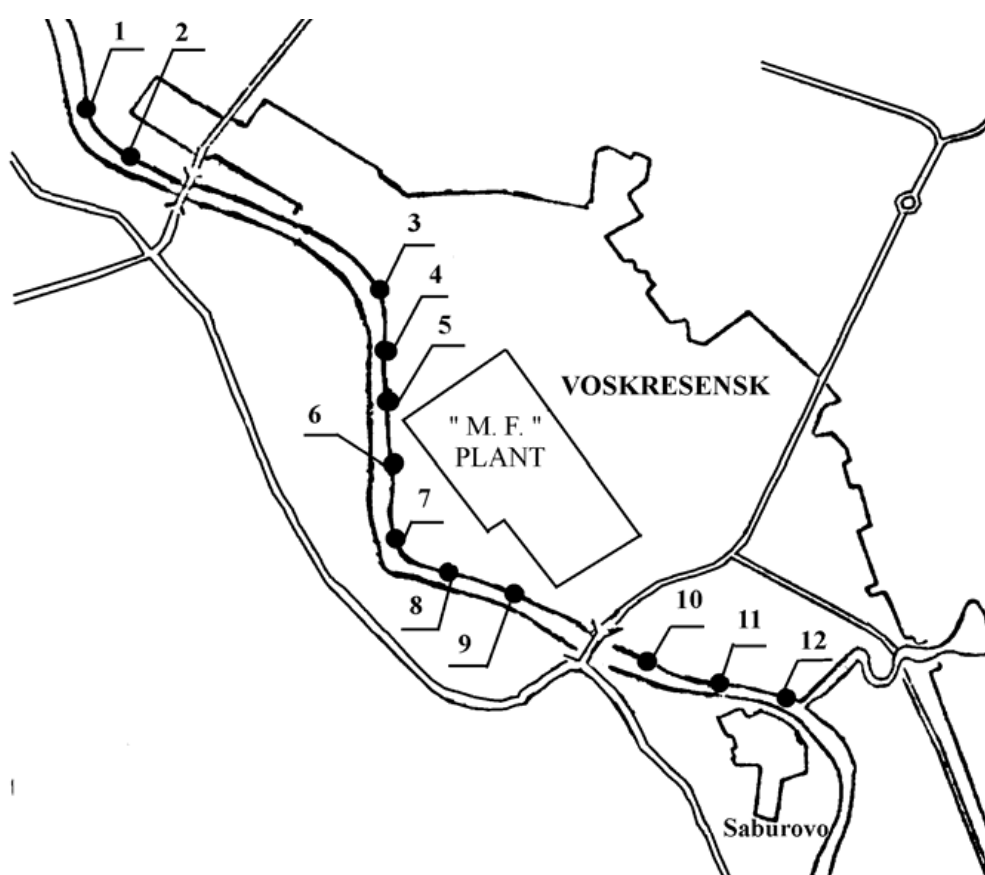

FIG. 4. The sampling sites along the Moscow River in the vicinity of the «Mineral Fertilizer» plant in Voskresensk.

Tap water was collected from the drinking fountains at the shops in clean plastic bottles of 1.5 L in volume. As the central water supply system provides the shops with fresh water, water samples were collected in only two shops (OSE-3 and OPE-3) and were conserved as required elsewhere [10].

### 2.1.6. Biosubstrates

To assess the effect of a chemical element on organism one should need to know its concentration in the diagnostic media (biosubstrates) of a man. Blood, urine and hair are usually used for such purposes of studying the anthropogenic impact on the environment.

Sometimes when studying the many-years effects, bone tissue (teeth) was used. In our case we omitted the labor-consuming and costly blood analyses.

The biosubstrates were collected from the occupational staff of the main shops of the «Mineral Fertilizer» plant, from the local residents (adults) of the adjacent districts and from the kinder-garden children of the town of Voskresensk. The list of occupations and relevant shops are given in Table III.

Collection of hair samples was carried out in accordance with the scheme shown in Fig. 5 [11] as adopted by the World Health Organization. Not less than 500 mg of hair for each sample was collected. Simultaneously with the collection of the hair samples, nail samples were collected from some of the examined employees. Samples of bone-tissue (teeth) were obtained from the stomatological medical ambulance of the plant. These samples were not differentiated by shop or occupation.

Age, sex, the total length of service in the shop and at the plant were fixed in a protocol (see APPENDIX I). To avoid surface contamination prior to analysis of the biosubstrate samples the hair, nails, and teeth were subjected to a special cleaning procedure. All of the collected samples were stored in hermetic zip-lock type plastic bags.

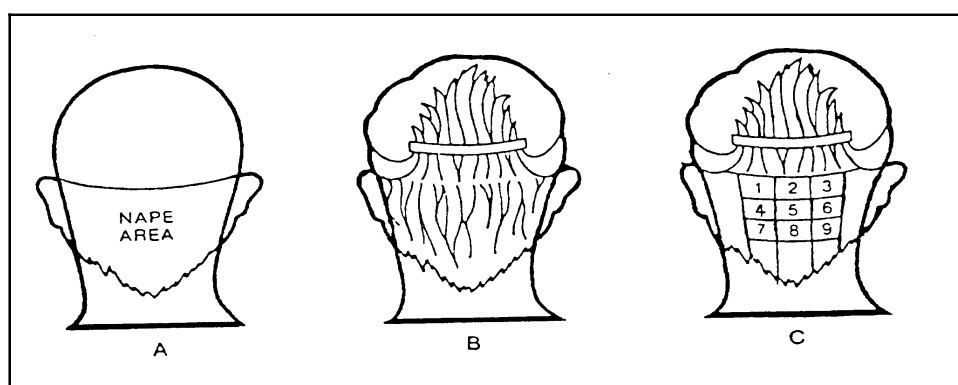

FIG. 5. Collecting hair samples [11].

- Locate a region on the scalp between the top of the ears and the nape of the neck (see figure A)
- Fasten the hair not to be cut out of the way with plastic clips (see figure B)
- Cut 10–20 strands of hair from 5–10 different sites in the occipital region of the scalp with stainless steel surgical scissors (see figure C). Save only the 5 cm of hair growing next to the scalp (if the hair is longer than 5 cm)

TABLE III: OCCUPATIONS OF THE EMPLOYEES EXAMINED AT THE «MINERAL FERTILIZERS» PLANT

Shop	Occupation	Shop	Occupation
OPE-1	Shop chief	AMM-2	Foreman
OPE-3	Chief deputy		Shipment foreman
OPE-4	Foreman		Hopper – operator
	Central Control Desk operator		Installation operator
	Power supply operator		Quality control dept. Supervisor
	Mechanic		Conveyor mechanic
	Electrician		Furnace fireman
	Measuring devices mechanic		Electrical engineer
	Installation operator		Mechanic
	Mechanic-repairman	OSE-3	Quality control dept. Supervisor
	Apparatus mechanic		Installation operator
	Conveyor mechanic		Mechanic-repairman
	Electrical welding mechanic		Electrical engineer
	Driver	CL	Engineer technologist
	Cleaner		Installation operator
AMM-1	Chief deputy		Technician
			Head engineer technologist
			Quality control technician

## 2.2. Analysis

The elemental concentrations of the collected samples were determined by means of instrumental neutron activation analysis (INAA), atomic absorption spectroscopy (AAS) and energy disperse X ray fluorescence spectroscopy (XRFA), as well as by ion-selective method, in the laboratories of the Geological Institute of RAS, Moscow, and JINR, Dubna. The analyses were carried out according to standard methods described elsewhere [4, 12–14].

Neutron activation analysis of the biosubstrates, aerosol filters, dust and technological samples was used to determine Na, Ca, Sc, Cr, Fe, Co, Zn, As, Br, Sb, REE, Au, Hg, Th, and U. The analysis was performed at IBR-2 reactor in Dubna and at IRT research reactor at Moscow Technical University (MPhI) as described in [4]. The integral flux of epithermal neutrons was  $10^{16}$ – $10^{17}$  n/cm<sup>2</sup>. The temperature of the container with the samples during irradiation did not exceed 70°C. The induced activity was measured with the using ORTEC  $\gamma$ -spectrometer of energy resolution 1.9 keV at the 1333 keV line of <sup>60</sup>Co.

For the determination of Sr, Ba, U, and Th in the samples ambient air collected on aerosol filters X ray fluorescence (XRF) analysis was used. The analysis was made by means of an X ray fluorescence analyser ARF-6 (Russian Federation) with the wave length dispersion (XRF-WD). The determined lead level was 0.1–3000 mg/kg. The achieved detection limit for lead in an aerosol filter makes up 0.1  $\mu$ g with an exposure time of 400 s. Detection limit for lead in paint equals 0.01 mg/cm<sup>2</sup> with an exposure time of 400 s.

For the Zn, Fe, Cu, Co, Cd, and Pb determination in the samples of drinking water, dust and human tissues (hair, urine, teeth) and also in plant samples method of flame atomic absorption spectrophotometry (FAAS) was used. Samples of drinking water and dust were analysed by means of a direct introduction of the prepared specimen into the acetylene-air flame of “Quant-2A” spectrophotometer (Russian Federation).

### 2.3. Analytical quality assurance

The analytical quality assurance was provided by using national and international standard reference materials (SRMs). As an example, the comparison of recommended and obtained by the authors results are given in Tables IV and V.

TABLE IV: INTERNATIONAL SRM OF HUMAN HAIR GBW 7601 (CHINA). CONCENTRATION IN mg/kg

Element	Na	Ca	Cr	Zn	Sb	Co	Cu	As
Recommend.	152 ± 10	2900 ± 200	0.37 ± 0.05	190 ± 5	0.095 ± 0.012	0.071 ± 0.008	10.6 ± 0.7	0.28 ± 0.04
Determined n = 27	160 ± 23	2600 ± 410	0.42 ± 0.08	185 ± 8	0.11 ± 0.01	0.08 ± 0.01	9.0 ± 0.9	0.29 ± 0.09
Element	Fe	Se	Hg	Pb	Cd	La	Ce	Br
Recommend.	54 ± 6	0.60 ± 0.03	0.36 ± 0.05	8.8 ± 0.9	0.11 ± 0.02	0.049	0.12	(0.36)
Determined n = 27	59 ± 5	0.47 ± 0.05	0.38 ± 0.03	8.0 ± 0.6	0.13 ± 0.03	0.07 ± 0.02	0.17 ± 0.05	0.37 ± 0.09

TABLE V: RESULTS OF THE ANALYSIS OF IAEA SRM LICHEN-336. CONCENTRATION IN mg/kg

Element	Na	Fe	Cr	Co	Pb	Cu	Zn	Fe	Cd
Recommend.	320	426	1.03	0.287	5.0	3.55	31.6	426	0.117
Determined n=17	300± 30	400±20	1.10±0.09	0.33±0.04	4.5±0.3	3.1±0.2	26±2	420±10	0.12±0.02

## 3. RESULTS AND DISCUSSION

### 3.1. Assessment of plant impact on occupational health and health of local residents

The main factor affecting the working area is air pollution.

Table VI contains data on concentrations of trace elements in air aerosols collected at the premises of the plant, at six shops and in the Central laboratory.

The analysis showed that:

- the fluorine content in air of the shops of oleum phosphate extraction is close to the maximum permissible levels;
- the concentration of other elements in air of workplaces do not exceed the maximum permissible levels in any shop;
- the maximum air pollution with airborne particulate matter as well as the maximum concentrations of Na, Ca, Cr, Fe, As, Sb, Sr, rare earth elements (REE) and Th occur at the loading-unloading sites;

- one should note relatively high, but not exceeding the maximum permissible levels of As in the air of the Central laboratory premises;
- no one element exceeds maximum permissible level for air of the working areas.

The trace element content of the occupational staff hair is given in Table VII. In general, the biochemical association of trace elements fully corresponds to its atmospheric one.

Correlation matrix for the elements from Table VII was calculated and is shown in Table VIII. No meaningful correlations were observed for the reported elements, including fluorine, for the whole amount of data. Similar situation takes place for the individual shops of the plant. The amount of samples for the other shops (n = 13) does not seem to be statistically reliable.

TABLE VI: TRACE ELEMENT CONTENT IN APM AT THE PREMISES OF THE «MINERAL FERTILIZER» PLANT (ng/m<sup>3</sup>)

Premises of the plant	PH*	F <sup>-</sup>	Na	Ca	Fe	Sr	La	Ce	Co	As	Cr	Sb	Th	U	Pb
Shop for oleum phosphate extraction (OPE-1)															
Turn around tanks	0.7		1	100	4.7	15	0.68	1.1	<0.1	15	140	1.5	6.9	<15	<0.05
Extractors	0.4	62	0.5	75	3.1	1.5	0.21	0.37	0.4	<0.1	570	0.8	3.3	<15	<0.05
Dozers	1.1		<0.1	260	9.6	11	1.8	3.6	2.7	10	550	0.6	15	<15	<0.05
Shop for oleum phosphate extraction (OPE-3)															
Operational. unloading	37		54.9	9600	380	620	64	112	96	23	1500	<0.5	690	<15	0.6
Platform, unloading	20		21	5900	160	150	37	64	180	33	1500	<0.5	420	<15	<0.2
Bunker, unloading	71	60	105	12000	430	880	113	194	140	30	1200	120	870	<15	<0.2
Evaporating dept.	1		0.3	70	6.6	4	0.16	0.22	<0.3	<0.1	160	1.2	2.2	<15	0.05
Extracting department	0.4		0.1	20	0.2	1	0.14	0.25	<0.1	<0.1	7	<0.5	1.4	<15	<0.02
Shop for oleum phosphate extraction (OPE-4)															
Loading of transporters	1		1.1	230	14	9.9	1.6	2.5	2.2	6	100	90	17	<15	<0.05
Separators	0.8	51	0.3	100	7	11	0.67	1.2	0.7	4.8	100	56	9	<15	<0.05
Unloading platform	65		32	8200	210	1100	53	93	120	50	1100	<0.5	460	<15	0.2
Shop for production of ammophos (AMM-1)															
Wet dust collectors	17		6.7	190	79	4.3	1.4	2.1	25	17	220	<0.5	190	<15	<0.05
Crushers	14	30	5.6	100	78	2.3	1	1.3	7.1	10	48	<0.5	130	13	<0.05
Loading	7.8		2.1	210	100	16	3.4	5	15	35	250	-	80	<15	<0.05
Shop for production of ammophos (AMM-2)															
Fine crusher	2		1.2	52	37	2.6	0.31	0.57	2.7	15	220	1.9	28	23	<0.05
Drum-dryer	0.5	32	0.1	<10	<1	0.6	0.028	0.07	<0.1	12	40	<0.5	1.4	<15	<0.05
Coarse crusher	0.8		1.4	<10	5.2	1.1	0.054	0.13	<0.1	11	50	<0.5	1.6	<15	<0.05
Shop for production of oleum sulfate extraction (OSE)															
Oleum absorption	<0.2		<0.1	<10	2.9	0.4	0.027	0.046	1.1	2.2	7.4	<0.5	0.2	<15	<0.05
Site of oleum mixture	0.6	-	0.7	<10	4	0.3	0.02	0.051	<0.1	5.5	240	0.7	<0.1	<15	<0.05
Water vapour purification	0.6		0.2	<10	4.3	0.04	0.023	0.065	2.8	36	7.2	1.1	<0.1	<15	<0.05
Central Laboratory CL															
Room No. 132 (09.06.97)	1.6		0.6	<10	66	1.3	0.1	0.24	3.7	85	270	24	<0.1	<15	0.15
Room No.132 (10.06.97)	0.7		1.1	<10	73	2.5	0.07	0.16	2.9	53	240	17	<0.1	<15	0.16
Room No 128 (10.06.97)	0.7		0.5	<10	46	1.4	0.06	0.13	<0.1	85	230	18	<0.1	<15	1.3
Max. permis. level [15.16]	-	50	-	-	4*10 <sup>3</sup>	-	-	-	5*10 <sup>5</sup>	1*10 <sup>4</sup>	1*10 <sup>6</sup>	5*10 <sup>5</sup>	7500	8800	10



TABLE VII: TRACE ELEMENT DISTRIBUTION IN HAIR (mg/kg) FOR THE WHOLE SET OF DATA (N = 94)

	F	Cr	Fe	Co	Zn	As	Se	Br	Sb	La	Ce	Hg	Th	U
C min	70	<0.2	20	<0.1	30	<0.1	<0.1	<0.1	<0.01	<0.1	<0.2	<0.1	<0.1	<0.1
C max.	4100	5.2	360	4.0	550	0.5	1.2	6.6	1.1	12	6.8	1.8	0.3	3.6
C mean.	790	1.4	77	0.3	170	0.2	0.4	1.2	0.07	1.3	2.0	0.3	0.2	0.6
C median	210	1.2	70	0.2	160	0.1	0.3	0.7	0.04	0.8	1.5	0.3	0.2	0.4
Distribution of trace elements in hair in the shops OPE (n = 44)														
C min	78	0.2	25	<0.1	100	<0.1	<0.1	<0.1	<0.01	0.4	0.8	<0.1	<0.1	<0.1
C max.	4100	5.2	180	4.0	290	0.5	1.2	6.6	1.1	12	6.8	0.7	0.3	1.8
C mean.	1200	1.7	78	0.3	160	0.2	0.4	1.2	0.08	1.6	2.3	0.3	0.2	0.53
C median	900	1.4	78	0.2	150	0.2	0.3	0.7	0.05	0.8	1.6	0.3	0.2	0.4
Distribution of trace elements in hair in the shops AMM (n = 26)														
C min	70	0.3	20	0.1	100	<0.1	<0.1	0.2	0.01	<0.1	<0.2	0.1	<0.1	<0.1
C max.	710	2.3	110	0.4	240	0.2	1.1	6.2	0.22	1.6	2.8	1.8	0.3	0.7
C mean.	270	1.1	62	0.2	170	0.2	0.4	1.3	0.06	0.6	1.2	0.34	0.2	0.5
C median	150	0.8	60	0.2	160	0.1	0.3	1.0	0.04	0.5	0.8	0.3	0.2	0.4
Distribution of trace elements in hair in the shop OSE (n = 11)														
C min	95	0.3	44	<0.1	30	<0.1	0.3	<0.1	<0.01	0.4	0.7	0.2	<0.1	<0.1
C max.	1200	1.4	350	0.2	200	0.1	0.4	1.4	0.11	2.8	4.5	1.7	0.1	0.6
C mean.	350	0.8	120	0.1	150	—	0.4	0.6	0.04	1.2	2.1	0.6	—	0.3
C median	120	0.8	70	0.1	170	—	0.4	0.4	0.03	0.8	1.4	0.3	—	0.3
Distribution of trace elements in hair in CL (n = 13)														
C min	95	0.3	30	0.1	50	<0.1	<0.1	<0.1	0.01	<0.1	<0.2	0.1	<0.1	0.2
C max.	210	2.0	84	0.3	550	<0.1	<0.1	1.9	0.11	3.5	6.2	0.6	0.1	3.6
C mean.	130	1.0	48	0.2	210	—	—	0.9	0.04	1.1	2.0	0.3	—	1.1
C median	120	0.9	40	0.2	190	—	—	0.9	0.04	0.8	1.4	0.2	0.1	0.3

TABLE VIII: CORRELATION MATRIX FOR THE WHOLE SET OF DATA (N = 94)

All shops	F	Cr	Fe	Co	Zn	Se	Br	Sb	La	Ce	Hg
F	1.00	0.13	0.03	-0.11	-0.15	-0.19	0.21	-0.13	0.28	-0.10	-0.01
Cr	0.13	1.00	0.46	0.29	0.07	0.36	-0.03	0.06	0.09	0.07	-0.05
Fe	0.03	0.46	1.00	0.12	0.08	0.51	0.07	0.16	0.18	0.25	0.08
Co	-0.11	0.29	0.12	1.00	0.09	0.28	-0.07	0.01	0.23	0.35	0.05
Zn	-0.15	0.07	0.08	0.09	1.00	0.15	-0.26	0.02	0.13	0.10	0.00
Se	-0.19	0.36	0.51	0.28	0.15	1.00	0.18	0.13	0.31	0.28	0.07
Br	0.21	-0.03	0.07	-0.07	-0.26	0.18	1.00	-0.05	-0.11	-0.10	-0.04
Sb	-0.13	0.06	0.16	0.01	0.02	0.13	-0.05	1.00	0.09	0.21	0.18
La	0.28	0.09	0.18	0.23	0.13	0.31	-0.11	0.09	1.00	0.60	0.11
Ce	-0.10	0.07	0.25	0.35	0.10	0.28	-0.10	0.21	0.60	1.00	0.26
Hg	-0.01	-0.05	0.08	0.05	0.00	0.07	-0.04	0.18	0.11	0.26	1.00

## Shop OPE (n=44)

OPE	F	Cr	Fe	Co	Zn	Se	Br	Sb	La	Ce	Hg
F	1.00	-0.03	-0.12	-0.19	-0.14	-0.27	0.22	-0.23	0.19	-0.32	0.01
Cr	-0.03	1.00	0.59	0.25	-0.11	0.31	-0.04	0.00	0.13	0.18	0.14
Fe	-0.12	0.59	1.00	0.24	0.14	0.64	0.20	0.11	0.30	0.42	0.37
Co	-0.19	0.25	0.24	1.00	0.15	0.28	-0.08	-0.02	0.23	0.43	0.14
Zn	-0.14	-0.11	0.14	0.15	1.00	0.47	-0.15	0.08	0.40	0.31	0.14
Se	-0.27	0.31	0.64	0.28	0.47	1.00	0.42	0.15	0.43	0.36	0.36
Br	0.22	-0.04	0.20	-0.08	-0.15	0.42	1.00	-0.14	-0.16	-0.17	-0.02
Sb	-0.23	0.00	0.11	-0.02	0.08	0.15	-0.14	1.00	0.07	0.29	0.53
La	0.19	0.13	0.30	0.23	0.40	0.43	-0.16	0.07	1.00	0.49	0.09
Ce	-0.32	0.18	0.42	0.43	0.31	0.36	-0.17	0.29	0.49	1.00	0.39
Hg	0.01	0.14	0.37	0.14	0.14	0.36	-0.02	0.53	0.09	0.39	1.00

## Shop AMM (n=26)

AMM	F	Cr	Fe	Co	Zn	Br	Sb	La	Ce	Hg
F	1.00	0.00	0.43	-0.41	0.34	-0.35	-0.25	0.03	0.10	-0.29
Cr	0.00	1.00	0.50	0.61	0.22	-0.32	-0.09	0.01	0.08	-0.14
Fe	0.43	0.50	1.00	0.19	0.30	-0.11	0.11	0.35	0.28	-0.06
Co	-0.41	0.61	0.19	1.00	0.46	-0.20	0.22	-0.04	0.20	-0.01
Zn	0.34	0.22	0.30	0.46	1.00	-0.61	0.31	-0.16	0.00	-0.06
Br	-0.35	-0.32	-0.11	-0.20	-0.61	1.00	0.06	0.41	0.32	0.11
Sb	-0.25	-0.09	0.11	0.22	0.31	0.06	1.00	0.25	0.17	0.09
La	0.03	0.01	0.35	-0.04	-0.16	0.41	0.25	1.00	0.94	-0.29
Ce	0.10	0.08	0.28	0.20	0.00	0.32	0.17	0.94	1.00	-0.26
Hg	-0.29	-0.14	-0.06	-0.01	-0.06	-0.11	0.09	-0.29	-0.26	1.00

The results obtained show that:

- hair of the occupational staff contain high concentrations of F, REE, Sb;
- the highest level for these elements is observed for the oleum phosphate extraction shop (OSE);
- this impact has a distinct gradation for the staff professions. The highest concentrations of fluorine in hair correspond to the lowest REE concentrations, and vice versa. The correlation coefficient for fluorine and REE is (-0.7). The greatest impact of fluorine on the occupational staff takes place in the sites of the vacuum evaporation. The REE maximal impact on the occupational staff takes place in the unloading sites;
- the level of element-pollutants impact is significantly lower in the shops on ammonium production. The most hazardous is the site for ammophos drying;
- the Central laboratory site is characterized by insignificant increase in REE content in hair of the occupational staff.

It is evident, that the most hazardous of all above mentioned elements is fluorine which is the most active natural oxidizer, belonging to the First group of toxicants [17]. As for REE, their presence is shown in practically all biological objects [6, 18, 19], but their biological role is not quite clear until now.

The fluorine content in hair allows one to estimate its impact on man. At present there is no physiologically motivated maximum permissible level for fluorine content in hair. However these levels exist for other biosubstrates, for urine, in particular [17].

The results on fluorine content in teeth and urine of the occupational staff of the plant and on local residents, living in the vicinity of the plant, are given in Table IX.

TABLE IX: FLUORINE CONTENT IN THE TEETH (mg/kg) AND URINE (mg/L) OF THE OCCUPATIONAL STAFF AND LOCAL RESIDENTS FROM THE VICINITY OF THE «MINERAL FERTILIZER» PLANT

Object of investigation	Teeth (n=16)	Urine (n=30)
Occupational staff having contact with fluorine	730	4.1
Occupational staff having no contact with fluorine	72	2.3
Adults	not determined	2.1
Children	not determined	1.8
Physiologically admissible level	not determined	1.0
Background	50	0.5

The data show that:

- the fluorine content in teeth practically reproduce the analogous data for hair;
- the maximum content of fluorine in urine of the occupational staff exceeds background values by a factor of 8;
- even for children, living in the vicinity of the plant, the fluorine content in urine exceeds the background values by a factor of 3.

It is known that the fluorine content in urine at the level of 3.3 mg/L and higher may cause *fluorosis* of different hardness [6, 17, 18].

The fluorine content in urine at the level of 2–3.3 mg/L leads to disfunction of cardiovascular system, liver, and serves the reason of osteoporosis. The level lower than 2 mg/L corresponds to practically healthy population. It is evident that the occupational staff of the plant and even a certain part of the local residents of the town of Voskresensk belong to the group of increased health risk with regard to the above mentioned disfunctions.

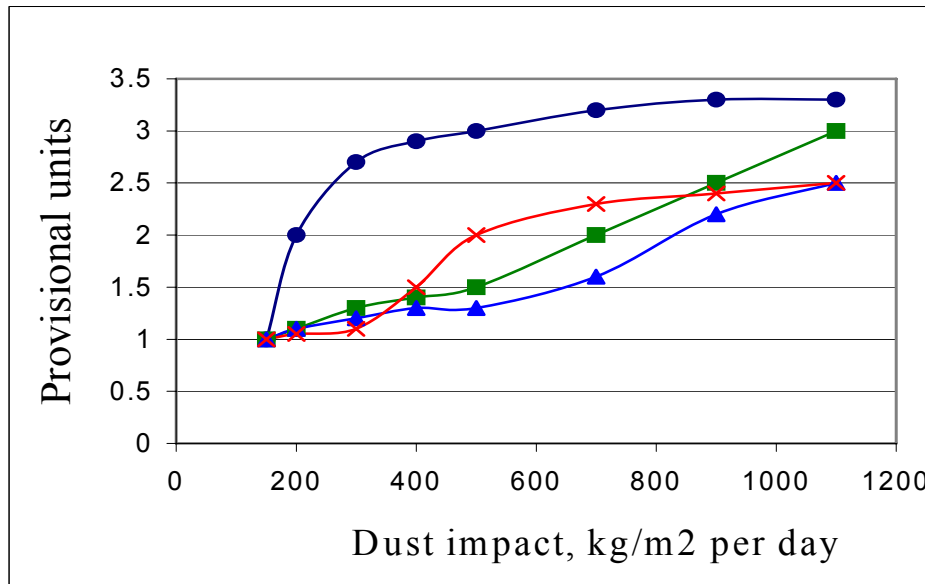

FIG. 6. Dynamic of children's morbidity in the area affected by the plant.

● – bronchial asthma; ■ – ititus; ▲ – sharp bronchitis; – shart pharengitis and tonsilites.

According to the existing estimations, general tendency in the increase of children's morbidity (most sensitive to the environmental impact) is observed [7] as demonstrated in Fig. 6.

#### 4. CONCLUSIONS

1. The nitrophosphate mineral fertilizers production is the source of emissions of F, Ca, Sr, and REE into the environment.
2. These chemical elements are mainly blown into the atmosphere.
3. No impact of the “Mineral Fertilizers” plant on the quality of water in the Moscow River was observed.
4. The elevated concentrations of F and REE are observed in biosubstrates of the occupational staff.

#### 5. SUMMARY

The intensive growth in the production of phosphorus fertilizers requires a thorough investigation of the deterioration of the environment at the sites where the fertilizers are manufactured. In our study we made an attempt to assess the environmental situation in the

workplaces of the “Mineral Fertilizers” plant in Voskresensk and adjacent to territories as well as to examine its impact on occupational staff and local residents. The results obtained could be generalized for the analogous plants elsewhere if to refer to the chemical composition of the raw material and final products of 5 enterprises for fertilizer production at the territory of the former Soviet Union. Practically all nitrophosphate fertilizers contain associations of element-pollutants. The applying of these fertilizers to the agricultural fields inevitable leads to the deterioration of soils by these elements and to their migration through the chain: agricultural vegetation – animal – man. To understand the global impact of this kind of industry on the environment, it is necessary to continue complex biogeochemical studies at a larger scale.

## REFERENCES

- [1] SOROKIN, E.P., KULACHKOVA, O.G., ONISCHENKO, T.L., A Comparative Analysis of the Industrial Impact on the Environment, in *Methods of Analysis of Industrial Anomalies*, IMGREE, Moscow (1984) 9–20 (in Russian).
- [2] NICHOLSON, F.A., JONES, K.C., JOHNSTON, A.E., The effect of phosphate fertilizers on long term changes in the cadmium content of crops and soil in the UK., *Proc. Int. Conf. Heavy Metals in the Environment*, Toronto, Canada **2** (1993) 215–218.
- [3] HAMAMO, H., LANDSBERGER, S., HARBOTTLE, G., PANNO, S., Studies of Natural Radioactivity and Heavy Metals in Phosphate Fertilizer. *J.Radioanal.Nucl. Chem.* **194**(2) (1995) 331–336.
- [4] GORBUNOV, A.V., GUNDORINA, S.F., ONISCHENKO, T.L., FRONTASYEVA, M.V., Development of a Combined Method to Carry out a Multielement Analysis for Environment Preservation, *J.Radioanal.Nucl.Chem.* **129**(2) (1989) 443–451.
- [5] VOLOKH, A.A., GORBUNOV, A.V., GUNDORINA, S.F., REVICH, B.A., FRONTASYEVA, M.V., CHEN SEN, P., Phosphorus Fertilizer Production as a Source of Rare-Earth Elements Pollution of the Environment. *The Science of Total Environment* **95** (1990) 141–148.
- [6] GORBUNOV, A.V., FRONTASYEVA, M.V., A.V., GUNDORINA, S.F., ONISCHENKO, T.L., MAK SJUTA, B.B., CHEN SEN, P., Effect of Agricultural Use of Phosphogypsum on Trace Elements in Soils and Vegetation. *The Science of Total Environment* **122** (1992) 337–346.
- [7] REVICH, B.A., SOTSKOV, Y.P., KOLESNIK, V.V., Trace element composition of children’s hair as an indicator of air pollution, in *Influence of Industrial Production on the Environment*, Nauka Publishers, Moscow (1987) 93–101 (in Russian).
- [8] FRONTASYEVA, M.V., GORBUNOV, A.V., GINDORINA, S.F., LYAPUNOV, S.M., OPREA, C.D., Workplace Monitoring and Occupational Health Studies at the Centre for Production of Phosphorus Moneral Fertilizers, Voskresensk (Moscow Region, Russian Federation), Using Nuclear and Related Techniques, Part II, Preprint of JINR, E14-99-68 1999, Dubna. (Submitted to the second research coordination meeting, May 17–20, 1999 Belo Horizonte, Brazil) (1999).
- [9] Normative Documents of Russian Federation for Control the Atmospheric Pollution, *Gidrometeoizdat*, Moscow (1991) 683 (in Russian).
- [10] State Norms GOST 18963-73 (1973) 13 and GOST 24481-80 (1980) 9 (in Russian).
- [11] DIPIETRO, E.S., PHILIPS, D.L, PASCHAL, D.C., NEESE, J.W., Determination of Trace Elements in Human Hair, *Biological Trace Element Research* **22** (1989) 83–100.

- [12] Children's Health at the Territories Polluted with Lead, Problems of Biological Monitoring, Risk Assessment, Preventive Treatment, Centers for Disease Control and Prevention, Reports, Moscow (1997).
- [13] SERIOGINA, I.V., DETATA-filters for Metal Preconcentration and Multielement Determination in Natural Waters, International J. Environ Anal.Chem. **57** (1994).
- [14] Screening Methods to reveal Groups of Elevated Risk among Workers Contacting Toxic Chemical Elements, Methodical Recommendations, Ministry of Health, Moscow, USSR, GULPP (1989) 22.
- [15] RYBALSKY, N.G., ZHAKETOV, O.L., ULYANOVA, A.E., SHEPELEV, N.P., Ecological Aspects of the Inventions' Expertise, Handbook, Moscow (1989) 447 (in Russian).
- [16] Norms of Radiation Safety, NRB-76/87, Moscow (1988) 151 (in Russian).
- [17] User Guide on Occupational Pathology, Moscow, Medicine (1981).
- [18] KIST, A.A., Phenomenology of Biochemistry and Bio-inorganic Chemistry, PhAC, Tashkent (1987) 236.
- [19] Trace Elements in Man, Proceedings of All-Union Symposium, Moscow (1989).

APPENDIX I

PROTOCOL No.	<i>Russian Academy of Sciences</i>	
<i>Family name</i>	<i>First name</i>	<i>Patronymic name</i>
<i>Date of birth</i>	<i>Home address</i>	
<i>Shop</i>	<i>Length of service in a given shop</i>	
<i>Occupation</i>	<i>Length of service at "Mineral Fertilizer" plant</i>	
<i>Type of sample</i>	HAIR	NAILS

# WORKPLACE MONITORING AND OCCUPATIONAL HEALTH STUDIES IN THE ŠOŠTANJ THERMAL POWER PLANT, SLOVENIA

R. JAČIMOVIĆ<sup>1</sup>, A.B. KOBAL<sup>2</sup>, B. STROPNIK<sup>3</sup>, A. SEŠEK-BRIŠKI<sup>4</sup>,  
I. FALNOGA<sup>1</sup>, Z. JERAN<sup>1</sup>, M. NEČEMER<sup>1</sup>

<sup>1</sup> Jožef Stefan Institute, Ljubljana, Slovenia

<sup>2</sup> Idrija Mercury Mine, Idrija, Slovenia

<sup>3</sup> ERICo, Velenje, Slovenia

<sup>4</sup> University Medical Centre Ljubljana, Clinical Institute of Clinical Chemistry and Biochemistry, Ljubljana, Slovenia

## Abstract

Workers at the Šoštanj Thermal Power Plant (TPP) in some sectors are exposed to high levels of coal dust, in others to dusty operations with ash and electrostatically precipitated fly ash, and in addition a force of welders is employed for maintenance and construction tasks. Welders work 5 to 6 hours per day and they are protected only from UV light. They are exposed to high concentrations of metals in inhaled welding fume. In previous work we determined the levels of trace and minor elements in the atmosphere at the working places. Aerosols were collected on Nuclepore polycarbonate membrane filters by a Casella personal sampler at different working places in the Šoštanj TPP. In this report, the emphasis is on the methodology and analytical development (instrumental neutron activation analysis, atomic absorption spectrometry and X ray spectrometry), and to a lesser extent on the results obtained up to now. Results obtained by the  $k_0$ -method, ET AAS and XRF techniques for urine samples collected from welders (TPP) and a control group from the Idria region (workers from workplaces unpolluted by metal dust) are presented and discussed.

## 1. SCIENTIFIC BACKGROUND AND SCOPE OF THE PROJECT

The general scope of the project is to obtain better knowledge of the state of air pollution in the Šoštanj Thermal Power Plant by performing workplace monitoring and occupational health studies involving determination of trace element air pollution arising from industrial emissions by analysing airborne particulate matter (APM) and biological samples taken from exposed workers.

Workers at the TPP in some sectors are exposed to high levels of coal dust, in others to dusty operations with ash and electrostatically precipitated fly ash, and in addition a force of welders is employed for maintenance and construction tasks. Contact between equipment and coal and fly ash leads to wear of the milling and transporting devices. To keep these devices in operation they must sometimes be repaired by welding with a special metal alloy which has a high content of heavy metals. Welders work 5 to 6 hours per day and are exposed to high concentrations of metals in the inhaled welding fume. Other workers are exposed to very high concentrations of fly ash. The major pollutants of concern in ash and coal are quartz particles, natural radioactive radionuclides from the <sup>238</sup>U chain, polycyclic aromatic hydrocarbons, heavy metals and other toxic microelements.

It is the goal of the project on its successful completion to achieve an improvement in the development and applications of nuclear and nuclear-related analytical techniques, and to obtain a database concerning trace element air pollution in the TPP. At the end of the project we focused on the influence of air pollution on welders' health.



## 2. METHODS

### 2.1. Sample collection

To perform the planned programme in the Šoštanj TPP, 5 sampling workplace sites were chosen. At two of them workers were exposed to a high concentration of coal dust and at three to ash. The sampling sites were chosen at the following workplaces:

- The boiler bunkers, Block 5, exposure — coal dust
- Control of the coal transportation system PE-05, exposure — coal dust
- The internal transport of ash, Block 4, exposure — ash
- The internal transport of ash, Block 5, exposure — ash
- Welders workroom, Block 5, exposure — ash, welding fume.

Aerosols were collected on a Nuclepore (Costar) polycarbonate membrane filter (37 mm diameter, pore size 0.45  $\mu\text{m}$ ) by a Casella personal sampler with a centrifugal separator facility. Sampling times were different for each chosen sampling site, but not higher than 5 hours.

For occupational health studies we collected urine samples from the chosen welder group. The observed group was exposed as usual in the welding shop for 4 working days. On the last day in the morning urine was sampled. Collected samples were divided for future analysis into two parts: one for AAS techniques and one for neutron activation analysis. For comparison of results between the exposed welder group and workers from the unpolluted area of metal we collected urine samples from workers from Idria region, in the same way.

For a better understanding of the influence of welding fume on welders' health, we took 5 samples of the electrodes used for welding.

### 2.2. Sample preparation

The electrodes collected were analysed by energy dispersive X ray fluorescence spectrometry in two ways. First: the electrode core and then the outer material of the electrodes. Measurements were performed directly on the surface.

The procedure for analysis of urine samples by  $k_0$ -instrumental neutron activation analysis was as follows:

Two mL aliquots of analysed materials were packed in supra pure plastic ampoules (SRP-SYSTEMS, Lexmond, Netherlands), together with an Al-0.1% Au alloy disc (Central Bureau for Nuclear Measurements, Geel, Belgium) of 5 mm diameter and 0.25 mm thick, and a 0.125 mm Zr foil (Goodfellow, Cambridge, UK), which served as comparator and fluence rate monitors, respectively. After irradiation samples were transferred to clean polypropylene mini scintillation vials (Atom Medical Ltd., Hove, UK) for measurement on an HPGe detector for counting the induced activities.

### **2.3. $k_0$ -based instrumental neutron activation analysis (INAA)**

All irradiations were performed in the channels of the TRIGA Mark II reactor of the Jožef Stefan Institute (IJS) in the carousel facility at a thermal neutron flux of  $1.1 \cdot 10^{12} \text{ n} \cdot \text{cm}^{-2} \cdot \text{s}^{-1}$  (irradiation time for each sample was 18–20 h). The radionuclides used in the determination of up to 50 elements in each sample, their half-lives and gamma-energies measured were given elsewhere [1]. Elemental concentrations and effective solid angle calculations were calculated by the software packet called KAYZERO/SOLCOI<sup>®</sup> [2].

### **2.4. Energy dispersive X ray fluorescence spectrometry (EDXRF)**

The X ray fluorescence (XRF) analysis system consisted of the X ray spectrometer, a set of annular radioisotopic excitation sources, and spectrum analysis and quantification software. An X ray spectrometer with a Si(Li) detector (Canberra Industries, Meriden, USA) with an active area of  $30 \text{ mm}^2$ , thickness of 3 mm and FWHM of 175 eV at 5.9 keV coupled to a Canberra S 100 multichannel analyser (MCA) was utilised. The circuitry also included an efficient pile-up rejection and live-time correction (PUR/LTC) system. The count rate linearity of the system was shown to be better than 2% for measurements with dead time in the range of 10 to 40%. For excitation, annular radioisotopic sources of  $^{109}\text{Cd}$  (0.3 GBq) and  $^{55}\text{Fe}$  (0.4 GBq), both supplied from Isotope Products Laboratories, Burbank, USA, were utilised. Spectra were processed and quantitative analysis performed using AXIL-PC and QAES (Quantitative Analysis of Environmental Samples) software (Canberra Industries). The system was calibrated using pure elements and their compounds (sensitivity calibration) [3].

### **2.5. Electrothermal Atomic Absorption Spectrometry (ET AAS)**

A SpectrAA 800 Zeeman (Varian Australia Pty Ltd Mulgrave, Victoria, Australia) Electrothermal Atomic Absorption Spectrophotometer was used. Gas type was argon. For Cd determination a light source of hollow cathode lamp was used. Urine samples were transferred to the pyrolytically coated graphite tubes by an automatic injector. The furnace was purged with argon of purity 99.9%. For standardisation Tritisol standards, manufactured by Merck was used. Water for dilution had resistivity greater than  $\text{M}\Omega \text{ cm}^{-1}$  at  $25^\circ\text{C}$ . For validation of the procedure for determination trace elements BioRad Lypochek urine (lot.no. 69041) was used. The bench area with AA spectrophotometer is located in a class-100 clean room (dust free conditions). We checked all labware and handling devices by leaching in a solution of 4% ultrapure grade  $\text{HNO}_3$ . Zeeman background correction was applied.

## **3. RESULTS AND DISCUSSION**

In this work we used two different techniques for determination of airborne particulates collected at different working places in the Šoštanj Thermal Power Plant: the  $k_0$ -standardization method of instrumental neutron activation analysis and X ray fluorescence analysis. Results for air filters loaded with welding fume and coal dust were measured twice: first by the XRF technique and after that by the  $k_0$ -method (INAA).

Results for aerosols in the welding shop sampled on the worker's monitor and the fixed monitor in the same place are significantly different from those at other workplaces, as expected, and are presented and compared in Table 5. Aerosols were collected on a Nuclepore filter by a Casella personal sampler. The results obtained by the two techniques are expressed

in ( $\mu\text{g}/\text{m}^3$ ). A comparison of results obtained by the two methods showed relatively good agreement. The difference in the results for elements like Cl, K and Fe can be explained by the fact that the whole filter sample was used for neutron irradiation ( $k_0$ -method) and only a part of the same filter was used for the XRF technique. Another reason for the rather higher results obtained by the XRF technique lies in the fact that during counting of air filters we used an absorber (thick Mylar foil) between the irradiation source and the filter, and after counting we removed the foil and we found later that some particulates were attached to the foil. This relatively small systematic error (the mass of loaded airborne particulate matter was not correct for the subsequent  $k_0$ -INAA analyses) was not taken into consideration.

Also, as shown in Table I, the concentrations found for most elements were twice high for the fixed monitor than for the worker's monitor. One possibility for explaining this is that the welder monitored had a pause for lunch during the observed period and for this time his pump did not operate (approximately 50 minutes). Another factor could be the different shifts of the monitors (the fixed one at 1.9 m, the workers at chest level). Also, ventilation conditions clearly vary within the working area.

In Table II, the concentrations for major elements in electrodes are shown. Results show that electrode cores have about 100% of Fe except for the Super Ni electrode. In the outer material of the electrode we found other elements, for example Ca, Cr, Mn, Cu, Ba, V, Ti and Mo at quite high levels.

In Table III and IV we show results obtained by the  $k_0$ -method for urine samples for the two groups, respectively. In Table V and VI we show same basic data for the exposed group of welders at the TPP and the control group. These results in general display no significant differences between the two groups. In accordance with other studies, however, differences exist between the smokers and non-smokers e.g. Cd. Also, the results found are within the normal range for non-exposed populations [4].

On the basis of annual medical examinations, long term occupational exposure of welders to dust did not appear to cause any important damage or important effects on respiratory functions although in some cases workers smoked. We also did not find any effects on tubular functions, in regard to measured urinary N-acetyl-beta-D-glucosaminidase (NAG) constituents, which were within the reference values. For a more reliable estimate, more welders should be studied.

TABLE I: COMPARISON OF  $K_0$ -INAA AND XRF RESULTS FOR CONCENTRATIONS OBTAINED IN AEROSOLS COLLECTED AT WORKING PLACES IN THE WELDING SHOP IN THE ŠOŠTANJ TPP; RESULTS ARE IN ( $\mu\text{g}/\text{m}^3$ )

Welding shop, 13.11.1998.								
El.	Worker-borne monitor				Fixed monitor			
	$k_0$ -INAA		XRF technique		$k_0$ -INAA		XRF technique	
	Result	<sup>1</sup> Unc.	Result	<sup>1</sup> Unc.	Result	<sup>1</sup> Unc.	Result	<sup>1</sup> Unc.
Ag	0,0155	0,0009			0,0251	0,0015		
Al	10,5	0,4			20,7	0,8		
As	0,76	0,03			1,73	0,07		
Au	0,00029	0,00002			0,00069	0,00003		
Ba	0,43	0,06			0,56	0,07		
Br	0,051	0,018			0,0397	0,0159		
Ca	96,4	4,0	89,5	9,3	87,1	6,7	105	11
Ce	0,0137	0,0010			0,0262	0,0015		
Cl	1,51	0,27			1,63	0,31		
Co	0,0569	0,0023			0,164	0,007		
Cr	1,16	0,06	<13		1,39	0,06	<13	
Cu	6,93	0,28	19,8	2,5	19,1	0,8	26	2,8
Fe	332	13	429	19	459	18	758	31
Ga	0,110	0,005			0,118	0,006		
Hf					0,0035	0,0003		
Hg	0,0545	0,0024			0,0056	0,0013		
K	147	6	132	14	115	5	118	12
La	0,0049	0,0003			0,0104	0,0005		
Mg					10,4	2,3		
Mn	33,5	1,3	51,1	5,5	28,4	1,2	40,8	5,4
Mo	2,81	0,11			2,98	0,12		
Na	6,71	0,29			11,0	0,5		
Ni							6,9	2,5
Pb			7,3	1,9			6,3	1,9
Pt	0,0447	0,0050			0,070	0,007		
Rb					0,067	0,021		
S			31,3	3,4			41,3	4,3
Sb	0,308	0,012			0,59	0,02		
Sc	0,0026	0,0001			0,0059	0,0002		
Se					0,0068	0,0019		
Si			<40				76,1	8,4
Sm	0,00077	0,00005			0,00170	0,00009		
Sn	1,37	0,15			1,98	0,15		
Sr							<2	
Ta					0,00185	0,00037		
Th	0,00244	0,00027			0,00679	0,00035		
Ti	4,70	0,89	5	0,5	6,75	1,08	9,1	0,9
U	0,0035	0,0005			0,00328	0,00066		
V	0,0748	0,0035			0,0754	0,0053		
W	0,0113	0,0011			0,0183	0,0013		
Yb					0,00148	0,00018		
Zn	0,79	0,03	<4		0,68	0,03	<5	

<sup>1</sup>Unc. = estimated uncertainty

TABLE II: RESULTS OBTAINED BY XRF TECHNIQUES FOR WELDING ELECTRODES USED IN WELDING SHOP AT TEŞ. RESULTS ARE IN %.

El.:	E DUR 400		E DUR 600		EVB 50		Super Ni		Boehler	
	core	outer material	core	outer material	core	outer material	core	outer material	core	outer material
Ba								59.2±5.4		
Ca	3.48±0.08	39.8±2.9		32.5±2.4		40.9±3.1		15.1±2.8		
Cr		8.66±0.83		25.0±1.7						
Cu										7.58±0.70
Fe	95.9±5.7	41.9±2.6	98.4±5.8	34.7±2.2	100±6	45.8±3.1		9.6±1.1		89.8±5.3
Mn	0.65±0.14	9.61±1.01				6.99±0.65				1.24±0.22
Mo		0.06±0.01		1.65±0.10				0.22±0.02		0.51±0.04
Nb								0.11±0.02		
Ni							98.4±5.8			
Sr								14.5±1.1		
Ti								1.10±0.08		
V				3.36±0.68		6.02±1.18				0.92±0.33
Zr				1.62±0.04		0.24±0.02		0.17±0.02		

TABLE III: RESULTS OBTAINED BY  $k_0$ -METHOD FOR URINE SAMPLES TAKEN FROM WELDERS FROM THE ŠOŠTANJ THERMAL POWER PLANT, SLOVENIA IN JANUARY 2001 AT THE END OF THE WEEKLY WORKING PERIOD. RESULTS ARE IN  $\mu\text{g/L}$  IF NOT OTHERWISE DESCRIBED.

Sample: Element:	Welder 1		Welder 2		Welder 3		Welder 4		Welder 5	
	Result	<sup>1</sup> Unc.	Result	<sup>1</sup> Unc.	Result	<sup>1</sup> Unc.	Result	<sup>1</sup> Unc.	Result	<sup>1</sup> Unc.
As	< 10		< 10		< 6		< 10		< 10	
Ba	< 200		< 200		< 100		< 200		< 200	
Br (mg/L)	1.71	0.07	2.02	0.08	1.91	0.08	1.62	0.07	1.96	0.08
Ca (mg/L)	51.6	4.6	110	8	109	6	89.0	5.3	234	10
Cd	< 100		< 100		< 50		< 100		< 100	
Cd*	0.84	0.05	0.48	0.03	1.44	0.05	0.51	0.03	0.78	0.05
Co	0.3	0.1	0.2	0.1	0.4	0.1	0.2	0.1	0.3	0.1
Cr	< 20		< 20		< 15		< 15		< 15	
Cs	10.8	0.5	6.0	0.3	9.4	0.4	5.4	0.3	10.0	0.4
Eu	< 1		< 1		< 1		< 1		< 1	
Fe	< 100		< 100		< 100		< 100		210	40
Hf	< 1		< 1		< 1		< 1		< 1	
Hg	< 1		< 1		< 1		< 1		< 1	
K (mg/L)	1730	170	1390	150	2250	120	1050	130	1230	150
La	< 3		< 3		< 2		< 3		< 3	
Mo	< 100		< 100		32.0	6.0	< 100		< 100	
Na (mg/L)	4950	200	4970	200	3730	150	3440	140	5220	210
Nd	< 30		< 30		< 30		< 30		< 30	
Rb (mg/L)	1.73	0.07	1.08	0.05	2.17	0.09	0.84	0.04	1.08	0.05
Sb	< 1		< 1		< 0.5		< 1		< 1	
Sc	< 0.5		< 0.5		< 0.5		< 0.5		< 0.5	
Se	20.0	3.0	18.0	3.0	18.0	2.0	16.0	2.0	14.0	3.0
Sm	< 1		< 1		< 1		< 1		< 1	
Sr	169	50	210	60	230	80	60	30	370	70
Ta	< 0.4		< 0.4		< 0.3		< 0.4		< 0.4	
Tb	< 0.4		< 0.4		< 0.3		< 0.4		< 0.4	
Th	< 1		< 1		< 1		< 1		< 1	
U	< 10		< 10		< 5		< 10		< 10	
Yb	< 1		< 1		< 1		< 1		< 1	
Zn	329	14	600	25	458	18	365	15	377	15

\* by AAS; <sup>1</sup>Unc. = estimated uncertainty

TABLE III: (CONTINUED)

Sample Element	Welder 6		Welder 7		Welder 8		Welder 9		Welder 10	
	Result	<sup>1</sup> Unc.	Result	<sup>1</sup> Unc.	Result	<sup>1</sup> Unc.	Result	<sup>1</sup> Unc.	Result	<sup>1</sup> Unc.
As	22.0	4.0	8.0	2.0	6	3	< 7		< 10	
Ba	< 200		< 200		< 200		< 200		< 200	
Br (mg/L)	2.23	0.10	1.43	0.06	1.92	0.08	2.19	0.09	1.38	0.08
Ca (mg/L)	127	12	205	9	158	8	137	6	94.4	3.9
Cd	< 50		< 50		< 40		< 50		< 100	
Cd*	0.79	0.05	0.31	0.02	0.45	0.03	0.31	0.02	1.23	0.04
Co	0.4	0.1	0.5	0.1	0.2	0.1	0.4	0.1	0.4	0.1
Cr	< 20		< 15		< 15		< 10		< 10	
Cs	26.1	1.1	5.6	0.3	7.3	0.3	16.8	0.7	7.0	0.3
Eu	< 1		< 1		< 1		< 1		< 1	
Fe	< 200		< 200		< 200		< 200		< 200	
Hf	< 1		< 1		< 1		< 1		< 1	
Hg	< 1		4.8	1.0	< 1		1.8	0.4	2.6	0.6
K (mg/L)	1880	170	912	140	1410	130	1700	120	1250	150
La	< 3		< 2		< 2		< 2		< 2	
Mo	52.0	10.0	88.0	8.0	< 60		< 60		78	23
Na (mg/L)	5220	210	3800	150	5610	220	3430	140	4000	160
Nd	< 30		< 30		< 30		< 30		< 30	
Rb (mg/L)	1.65	0.07	0.89	0.04	1.23	0.05	2.56	0.11	1.10	0.05
Sb	0.9	0.2	< 0.5		< 0.5		< 0.5		< 0.5	
Sc	< 0.5		< 0.4		< 0.4		< 0.4		< 0.2	
Se	19.0	3.0	16.0	2.0	18.0	3.0	17.0	2.0	15.0	3.0
Sm	< 1		< 1		< 1		< 1		< 1	
Sr	300	90	220	50	150	40	130	40	280	60
Ta	< 0.4		< 0.4		< 0.4		< 0.4		< 0.4	
Tb	< 0.4		< 0.4		< 0.4		< 0.4		< 0.4	
Th	< 1		< 1		< 1		< 1		< 1	
U	< 5		< 5		< 5		< 5		< 10	
Yb	< 1		< 1		< 1		< 1		< 1	
Zn	329	14	742	30	745	30	453	20	495	20

\* by AAS; <sup>1</sup>Unc. = estimated uncertainty

TABLE IV: RESULTS OBTAINED BY  $k_0$ -METHOD FOR URINE SAMPLES TAKEN FROM CONTROL GROUP OF WORKERS FROM THE IDRIA REGION IN APRIL-MAY 2000 AT END OF WEEKLY WORKING PERIOD (URINE COLLECTED 8 HOURS). RESULTS ARE IN  $\mu\text{g/L}$  IF NOT SIGNED OTHER.

Sample: El.:	Control 1		Control 2		Control 3		Control 4		Control 5		Control 6		Control 7		Control 8	
	Result	<sup>1</sup> Unc.	Result	<sup>1</sup> Unc.	Result	<sup>1</sup> Unc.	Result	<sup>1</sup> Unc.	Result	<sup>1</sup> Unc.	Result	<sup>1</sup> Unc.	Result	<sup>1</sup> Unc.	Result	<sup>1</sup> Unc.
As	< 20		< 20		32.0	9.0	< 20		50.0	7.0	2.7	1.0	< 20		22.0	7.0
Ba	< 200		< 200		< 200		< 200		< 200		< 200		< 200		< 200	
Br (mg/L)	2.45	0.10	1.43	0.06	1.26	0.05	1.68	0.07	1.57	0.060	0.58	0.03	2.10	0.09	0.67	0.03
Ca (mg/L)	87.2	3.9	101	5	177	7	79.0	3.8	137	7	24.5	2.7	93.7	4.3	32.2	3.5
Cd	< 50		< 50		< 60		< 40		< 50		< 20		< 30		< 20	
Cd*	1.12	0.04	1.37	0.05	0.93	0.03	1.22	0.04	0.67	0.04	0.65	0.04	1.11	0.04	2.70	0.09
Co	0.12	0.02	< 0.1		0.15	0.02	< 0.1		0.30	0.03	0.12	0.03	< 0.1		< 0.1	
Cr	< 15		< 15		< 15		< 10		< 20		< 15		< 15		< 15	
Cs	8.44	0.34	9.18	0.37	4.70	0.20	6.10	0.30	7.80	0.40	2.30	0.20	5.70	0.40	3.40	0.20
Eu	< 1		< 1		< 1		< 2		< 2		< 2		< 1		< 1	
Fe	< 400		< 400		< 300		< 400		< 600		< 500		< 1000		< 800	
Hf	< 0.8		< 1		< 0.8		< 0.8		< 1		< 0.8		< 1		< 1	
Hg	0.4	0.2	1.7	0.5	< 2		< 2		0.6	0.2	< 2		1.5	0.4	< 1	
K (mg/L)	444	80	2590	130	1600	130	1360	110	1080	95	571	57	2280	115	315	53
La	< 1		< 1		< 1		< 1		< 1		< 1		< 1		< 1	
Mo	< 50		< 50		< 50		33.0	7.0	< 50		< 20		17.0	5.0	< 20	
Na (mg/L)	4150	166	2750	110	2320	95	2650	105	2650	105	1160	45	2740	110	1180	50
Nd	< 30		< 30		< 30		< 30		< 40		< 20		< 30		< 30	
Rb (mg/L)	1.09	0.04	2.04	0.08	1.22	0.05	1.39	0.060	1.97	0.080	0.62	0.02	1.82	0.08	0.35	0.02
Sb	< 0.5		< 0.5		< 0.5		< 0.5		< 0.5		< 0.4		< 0.5		< 0.5	
Sc	< 0.1		< 0.1		< 0.1		< 0.1		< 0.1		< 0.1		< 0.1		< 0.1	
Se	13.8	2.2	19.2	3.1	13.7	2.1	12.5	2.3	< 20		6.3	1.0	8.7	1.4	< 10	
Sm	< 1		< 1		< 1		< 1		< 1		< 0.4		< 0.4		< 0.5	
Sr	190	55	230	120	480	80	220	40	310	100	206	50	< 300		< 300	
Ta	< 0.4		< 0.5		< 0.3		< 0.3		< 0.5		< 0.5		< 1		< 1	
Tb	< 0.3		< 0.4		< 0.3		< 0.3		< 0.3		< 0.5		< 1		< 0.6	
Th	< 0.5		< 1		< 0.5		< 0.5		< 1		< 0.5		< 1		< 0.5	
U	< 5		< 5		< 5		< 3		< 5		< 2		< 2		< 2	
Yb	< 1		< 1		< 1		< 1		< 1		< 1		< 1		< 1	
Zn	391	16	568	23	476	20	529	21	340	15	230	12	676	27	227	18

\* by AAS; <sup>1</sup>Unc. = estimated uncertainty



TABLE V: SOME BASIC DATA FOR EXPOSED GROUP OF WELDERS FROM ŠOŠTANJ THERMAL POWER PLANT

Code	Year of birth	Working period (years)	Smoking habits Cigarettes/years	Cough	Dyspnea	Spirometry	Cd in urine ( $\mu\text{g/L}$ )	Urine NAG** (nkat/mmol creatinine)	Urine creatinine (mmol/L)
Welder 1	1950	32	20/20 y	Morning	Non present	Airways obstruction suggested	$0.84 \pm 0.05$	0.84	14.63
Welder 2	1948	30	Non-smoker	Non	Non present	Normal*	$0.48 \pm 0.03$	0.89	10.18
Welder 3	1959	14	40/15 y	Morning	Non present	Airways obstruction suggested	$1.44 \pm 0.05$	3.32	15.5
Welder 4	1960	21	20/19 y	Non	Non present	Normal*	$0.51 \pm 0.03$	2.44	7.45
Welder 5	1959	20	30/20 y	Morning	Non present	Airways obstruction suggested	$0.78 \pm 0.05$	4.46	13.29
Welder 6	1954	24	15/20 y	Non	Non present	Normal*	$0.79 \pm 0.05$	4.03	12.77
Welder 7	1961	21	Non-smoker	Non	Non present	Normal*	$0.31 \pm 0.02$	2.16	11.2
Welder 8	1965	16	Non-smoker	Non	Non present	Normal*	$0.45 \pm 0.03$	1.15	15.81
Welder 9	1967	14	20/10 y	Non	Non present	Normal*	$0.31 \pm 0.02$	5.42	13.41
Welder 10	1968	15	20/13 y	Morning	Non present	Airways obstruction suggested	$1.23 \pm 0.04$	2.29	17.21

\* Normal: Normal FEVL/FVC ratio, no evidence of airway obstruction

\*\* NAG: Reference values determined in our laboratories are in range from 1.45 to 9.19 nkat/mmol creatinine. (0.77 to 4.87 U/g creatinine) [5], [6]

TABLE VI: SOME BASES DATA FOR NON-EXPOSED GROUP OF WORKERS FROM IDRIA REGION (TAKEN AS CONTROL GROUP).

Code	Year of birth	Working period (years)	Smoking habits Cigarettes/years	Cough	Dyspnea	Spirometry	Cd in urine ( $\mu\text{g/L}$ )	Urine NAG** (nkat/mmol creatinine)	Urine creatinine (mmol/L)
Control 1	1963	19	Non-smoker	Morning	Non present	Normal*	$1.12 \pm 0.04$	2.18	17.1
Control 2	1952	30	Non-smoker	Morning	Non present	Normal*	$1.37 \pm 0.05$	4.2	18.0
Control 3	1963	22	Non-smoker	Non	Non present	Normal*	$0.93 \pm 0.03$	1.4	10.0
Control 4	1946	35	20/20 y	Morning	Non present	Airways obstruction suggested	$1.22 \pm 0.04$	5.1	14.0
Control 5	1972	10	Non-smoker	Non	Non present	Normal*	$0.67 \pm 0.04$	3.1	1.6
Control 6	1948	33	Non-smoker	Non	Non present	Normal*	$0.65 \pm 0.04$	8.6	5.7
Control 7	1951	32	25/10 y	Non	Non present	Normal*	$1.11 \pm 0.04$	5.7	12.6
Control 8	1965	17	25/17 y	Morning	Non present	Normal*	$2.70 \pm 0.09$	3.0	16.1

\* Normal: Normal FEV1/FVC ratio, no evidence of airway obstruction

\*\* NAG: Reference values determined in our laboratories are in range from 1.45 to 9.19 nkat/mmol creatinine. (0.77 to 4.87 U/g creatinine)

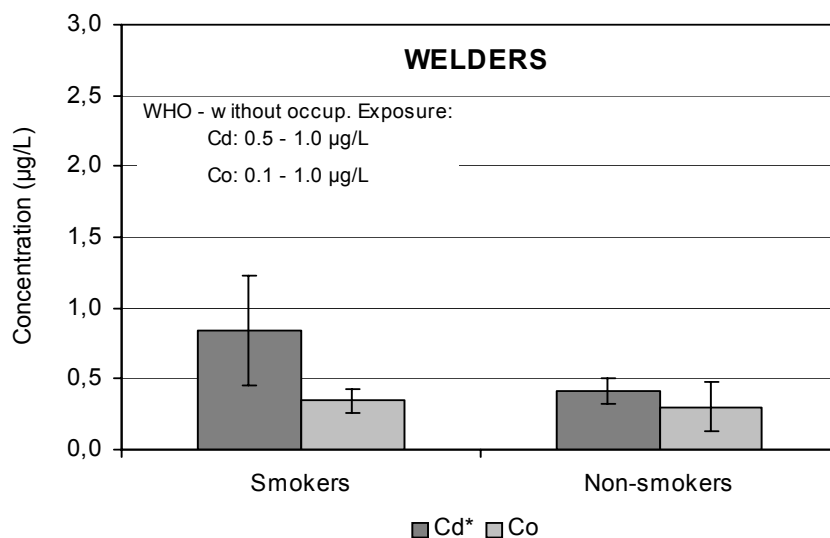

FIG. 1. Comparison of results for Cd and Co in urine of exposed welders between smokers and non-smokers.

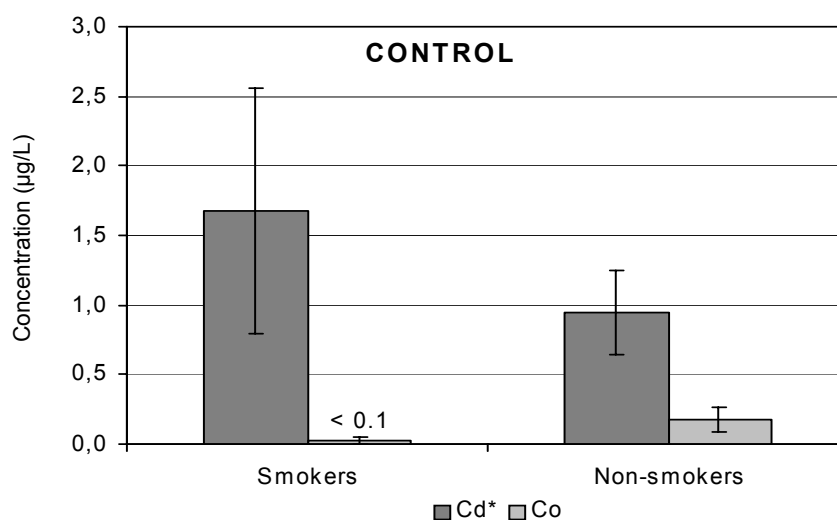

FIG. 2: Comparison of results for Cd and Co in urine of control workers between smokers and non-smokers.

### ACKNOWLEDGEMENT

We thank Mr. Jaroslav Vrtačnik, Director of Šoštanj TPP, for cooperation and access to the workplaces.

## REFERENCES

- [1] SMODIŠ, B., JAĆIMOVIĆ, R., STEGNAR, P., JOVANOVIĆ, S., Multielement analysis of NIST proposed SRM 1547 Peach Leaves, *J. Radioanal. Nucl. Chem., Articles* **160**(1) (1992) 101–108.
- [2] KAYZERO/SOLCOI for reactor-neutron activation analysis (NAA) using the  $k_0$ -standardization method, DSM Research, Geleen, Netherlands, Dec. (1996).
- [3] KUMP, P., NEČEMER, M., SMODIŠ, B., JAĆIMOVIĆ, R., Multielement analysis of rubber samples by X ray fluorescence, *Applied Spectroscopy* **50** (1996) 1373–1377.
- [4] WORLD HEALTH ORGANIZATION, Biological Monitoring of Chemical Exposure in the Workplaces, Guidelines, Geneva **1** (1996).
- [5] GIBEY, R., DUPOND, J.L., HENRY, J.C., Urinary N-acetyl-beta-D-glucosaminidase (NAG) isoenzyme profiles: a tool for evaluating nephrotoxicity of aminoglycosides and cephalosporins, *Clin. Chim. Acta* **137** (1984) 1–11.
- [6] MORITA, A., NUMATA, Y., KOSUGI, Y., et al., Stabilities of N-acetyl-beta-D-glucosaminidase (NAG) isoenzymes in urine: advantage of NAG isoenzyme B measurement in clinical applications, *Clin. Chim. Acta* **278** (1998) 35–43.



# EVALUATION OF THE RADIOLOGICAL IMPACT OF MINERAL PRODUCTS AS A FUNCTION OF PARTICLE SIZE DISTRIBUTION

A. FAANHOF, M. VAN STADEN, I. KUNGOANE

NECSA, Pretoria, South Africa

## Abstract

Naturally occurring radioactive material, often referred to as NORM, is found throughout the earth's crust and forms part of the natural radiation background to which all humans are exposed. Normally the radionuclides found in NORM are members of the radioactive decay chains of  $^{238}\text{U}$ ,  $^{235}\text{U}$  and  $^{232}\text{Th}$ . The main routes of radionuclide intake are through inhalation of airborne dust and ingestion of food and water. Furthermore, internal irradiation of the bronchial epithelium by alpha particles from the short lived progeny of radon constitutes substantially to the exposure from natural sources.

Human activities like mining and mineral processing and extractions of petroleum products may concentrate the radionuclides in the work environment. Such alteration of the natural environment can increase the radiation exposure of workers and the public.

An important factor affecting the radiation dose received through inhalation of airborne dust is the size of the particles. The size, to a large extent, determines where the radioactivity deposits in the lung and accordingly the tissue that will be affected.

South Africa is a major exporter of mineral products. These minerals may contain natural radionuclides at varying levels depending on the particle size. Most of these mineral products are processed further in local or overseas beneficiation processing plants.

The South African Nuclear Energy Corporation (NECSA) developed a protocol to certify the radiological impact on workers from respirable airborne dust potentially generated by handling and/or processing of materials contaminated with NORM. An overview will be provided of the incentive and outcome of the research based on a number of materials known to contain varying amounts of natural radionuclides.

## 1. INTRODUCTION

Mineral products like zircon, rutile, ilmenite, monazite, baddeleyite, coal and titanium slag obtained from various mineral deposits in South Africa contain noticeable quantities of TENORM. Dust generated during transport, handling and reprocessing of the material could pose a radiological risk on inhalation of the respirable fraction. An analytical procedure has been developed to quantify this potential risk to workers, which may alleviate intensive workplace and personnel monitoring.

## 2. OUTLINE OF THE RADIOANALYTICAL PROCEDURE

The following sequence is recommended:

- Representatively sample about 1–2 kg of the mineral product for analyses at a Radioanalytical laboratory.
- Determine the gross  $\alpha/\beta$ -activity of a representative sub-sample. If the gross  $\alpha$ -activity and the gross  $\beta$ -activity are both  $< 200$  mBq/g no potential radiological risk is to be expected from transport, handling and/or reprocessing the bulk material (200 mBq/g is the exemption level in South Africa for licensing requirements on handling materials).
- If one of the limits is exceeded then determine the particle size distribution using a laser diffraction technique (e.g. Malvern, see note 1 chapter 7).

- Determine the potential amount respirable airborne dust that can be generated from the mineral. For practical reasons the respirable fraction may be defined as the fraction containing particles < 10 µm.
- Separate the dust with a Flosep tube (see note 2, chapter 7). Flosep tubes can be made according to the required cut-off fraction of the particle size.
- Determine the concentration of key nuclides from the  $^{238}\text{U}$ ,  $^{235}\text{U}$  and  $^{232}\text{Th}$  decay series. Radioanalytical techniques like INAA,  $\alpha$ -spectrometry and chemical separation procedures can be applied.
- Assume a default concentration of respirable dust in the workplace of  $150 \mu\text{g}/\text{m}^3$  and determine the potential yearly dose.
- Issue a certificate indicating the potential dose incurred from the material on transport, handling or reprocessing.

### 3. ANALYSIS OF THE BULK MATERIAL VERSUS THE RESPIRABLE FRACTION

Practical experience gained at NECSA's Radioanalytical laboratories on numerous samples analysed, showed that the distribution of TENORM radionuclides may vary as a function of particle size, even so much that the gross activity between a sample representative of the sample delivered to the laboratory and a sub-sample representing the fine particles only, could differ up to a factor 200 to both sides. Furthermore, as a consequence of physical and chemical processes in the extraction of the minerals or concentrates from the ore, the equilibrium between the nuclides within the individual decay series may be extremely disturbed. Accordingly, it is important to analyse the individual radionuclides of these series and not only the parent nuclides. Radionuclides to be quantified for proper dose evaluations are  $^{238}\text{U}$ ,  $^{234}\text{U}$ ,  $^{230}\text{Th}$ ,  $^{226}\text{Ra}$ ,  $^{210}\text{Pb}$ ,  $^{210}\text{Po}$ ,  $^{235}\text{U}$ ,  $^{231}\text{Pa}$ ,  $^{227}\text{Ac}$ ,  $^{232}\text{Th}$ ,  $^{228}\text{Ra}$  and  $^{228}\text{Th}$ , while  $^{227}\text{Th}$ ,  $^{223}\text{Ra}$  and  $^{224}\text{Ra}$  may be added to evaluate the dose to workers in the mineral extraction plants.

### 4. PRACTICAL EXAMPLES

Zircon, Coal, Coal Ash, Titanium slag, Monazite and Slime have been selected in this investigation. All products are from local producers and are known to have NORM over a wide concentration range between the chosen matrices.

#### 4.1. Zircon

The actual material is a zircon concentrate with 97% zircon ( $\text{ZrSO}_4$ ). Two suites of this mineral were obtained from different South African producers. Zircon is able to scatter and reflect light. It is used in ceramics industry as an opacifier, in tableware, tiles and sanitary ware. Most of the tiles, baths and basins, cups, saucers and plates in our homes obtain their finish from the zircon melted into their surfaces. Zircon sand is also used in the foundry industry as moulding sand because it is resistant to high temperatures and does not expand significantly when it is heated. The high melting point of zircon also allows the mineral to be used as refractory lining in glass and steel production where it prevents the molten glass or metal from damaging the side of the ladles or kilns. Accordingly, the radiological risk of handling and processing this material is important not only for workplace monitoring but also for the end-user, the public.

## 4.2. Titanium slag

The main mineral phase is armalcolite ( $\text{FeMgTi}_4\text{O}_{10}$ ), with minor amounts (5–20 percent) of anatase and pseudo-brookite. Rutile and kennyite are present in trace amounts. Because of its strength and light weight, titanium is used in metallic alloys and as a substitute for aluminium. Alloyed with aluminium and vanadium, titanium is used in aircraft for firewalls, outer skin, landing-gear components, hydraulic tubing, and engine supports. The compressor blades, discs, and housings of jet engines are also made of titanium. Titanium is widely used in missiles and space capsules, the Mercury, Gemini, and Apollo capsules were made largely of titanium. The relative inertness of titanium makes it available as a replacement for bone and cartilage in surgery and as a pipe and tank lining in the processing of foods. It is used in heat exchangers in desalination plants because of its ability to withstand saltwater corrosion. In metallurgy, titanium alloys are employed as deoxidizers and denitrogenizers to remove oxygen and nitrogen from molten metals. Also here, the radiological risk of handling and processing this material is important not only for workplace monitoring but also for the end-user, the public.

## 4.3. Coal ash

Coal ash results from the combustion of coal. The fraction by weight of inorganic solid material remaining after high-temperature combustion of coal is generally termed the ash fraction or ash content. Most of the heavier ash and incompletely combusted organic matter drop to the bottom as slag or bottom ash. The combustion of coal is the main source for electricity, generation in South Africa and will increase in the near future. As the combustion of coal increases, so will the magnitude of environmental and human health hazards associated with trace elements and radionuclides mobilized by the coal fuel cycle.

## 4.4. Coal

Various types of coal (e.g. lignite, bituminous coal, anthracite) are used on large scales in South Africa for industrial and household purposes. Large quantities are mined transported and processed. South African coal does contain NORM in varying concentrations dependent on the origin. Coal was taken into consideration specifically for evaluating the possible radiological risk due to respirable airborne dust in the workplace (i.e. mining and processing). Furthermore, South Africa is a major exporter of coal and the radioactivity content may influence market values.

## 4.5. Slime

In South Africa, the major tailings are generated by the gold and copper mining and mineral processing industries. From the geo-technical perspective, “sand” and “slime” tailings have often been intentionally segregated to enable reprocessing of slimes at a later date with improved recovery methods. Both operating practices at disposal areas and natural forces tend to segregate tailings by particle size. Accordingly, it is important to understand how the radiological characteristics (e.g. nuclide concentration, radon emanation) of tailing material may vary as a function of particle size, specifically when reprocessing is envisaged. A general trend has been observed that slimes (considered as the -200 mesh fraction) has elevated contents of NORM compared to the sands (+200 mesh).



## 4.6. Monazite

Monazites, anhydrous phosphates of the rare earth elements group -the general formula being (Ce, La, Y, Th) PO<sub>4</sub>, usually contain elevated levels of NORM. The mineral provides the valuable lanthanides widely used in industry (e.g. europium in TV-screens and colour monitors). Reprocessing of the mineral may pose a radiological risk.

## 5. PROCEDURE

Sub-samples of the six mineral products were prepared and taken for particle size analysis. The same sub-sample was separated using an AS 18 Flosep Tube to obtain the fraction < 5 µm. Thereafter, samples were analysed for NORM using high- and low-energy gamma-spectrometry and INAA. In this paper we only report on uranium and thorium concentrations obtained to illustrate the concentration distribution according to particle size. Other data will be reported elsewhere on evaluation of the radiological risk of the respirable dust fraction of minerals.

## 6. RESULTS AND DISCUSSION

It should be emphasized that the materials chosen may not be representative for similar materials obtained from the various manufacturers in South Africa and may differ from batch to batch depending on the manufacturing and storage conditions. It is not the intention of this study to determine the full radiological impact assessment of the materials. The examples provided merely serve the purpose to illustrate the proposed analysis and evaluation protocol.

### 6.1. Zircon

Two zircon samples as received at the laboratories from different manufacturers showed a coarse particle structure on visual observation. The samples were mechanically sieved to obtain information on the distribution of NORM according to particle size. Uranium and thorium analysis showed the following results:

Particle size (x)	Sample Activity in Bq/g			
	Material A		Material B	
	<sup>238</sup> U	<sup>232</sup> Th	<sup>238</sup> U	<sup>232</sup> Th
x<75 µm	3.63 ± 0.37	0.49 ± 0.05	4.15 ± 0.42	0.59 ± 0.06
75 µm<x<125 µm	3.29 ± 0.33	0.47 ± 0.05	4.15 ± 0.42	0.51 ± 0.05
125 µm<x<150 µm	3.55 ± 0.36	0.58 ± 0.05	3.73 ± 0.38	0.51 ± 0.05
150 µm<x<180 µm	3.19 ± 0.32	0.61 ± 0.04	3.37 ± 0.34	0.46 ± 0.04
x>180 µm	2.91 ± 0.30	0.50 ± 0.04	3.42 ± 0.34	0.59 ± 0.04

Uranium tends to increase the smaller the size, while thorium seems to be more or less constant. It is expected that these materials do not pose a direct radiological risk through inhalation of respirable dust, unless the material is ground for reprocessing purposes.

## 6.2. Titanium slag

The titanium slag sample also showed a coarse grain structure on visual inspection. The sample has been mechanically sieved to obtain information on the distribution of NORM according to particle size. The following results were obtained:

Particle size (x)	Sample Activity in Bq/g	
	<sup>238</sup> U	<sup>232</sup> Th
x < 53 μm	< 0.13	0.08 ± 0.01
53 μm < x < 75 μm	< 0.13	0.07 ± 0.01
75 μm < x < 125 μm	< 0.12	0.05 ± 0.01
125 μm < x < 150 μm	< 0.13	0.05 ± 0.01
150 μm < x < 180 μm	< 0.11	< 0.04
x > 180 μm	< 0.12	< 0.04

Thorium seems to increase the smaller the size, while uranium was below the limit of determination applied. It is expected that this material will not pose a direct radiological risk through inhalation of respirable dust, unless the material is ground for reprocessing purposes. Future work should include the respirable fraction as the size distribution did show a fair fraction in the region below 10 μm.

## 6.3. Coal ash

The coal ash sample showed a fine grain structure on visual inspection. The sample has been mechanically sieved, while the smallest particle fraction was separated using the Flosep separator. The following information on the distribution of NORM according to particle size has been obtained:

Particle size (x)	Sample Activity in Bq/g	
	<sup>238</sup> U	<sup>232</sup> Th
x < 10 μm	0.17 ± 0.02	0.16 ± 0.01
10 μm < x < 53 μm	0.14 ± 0.02	0.16 ± 0.01
53 μm < x < 75 μm	0.20 ± 0.03	0.17 ± 0.01
x > 75 μm	0.15 ± 0.02	ND

Both thorium and uranium seem to be homogeneously distributed independent of the particle size. Analysis of the Flosep separated respirable fraction is probably not required and data can be obtained from the bulk sample.

## 6.4. Coal

The coal dust sample received at the laboratory showed a fine grain structure on visual inspection. The sample has been mechanically sieved, while the smallest particle fraction was separated using the Flosep separator. The following information on the distribution of NORM according to particle size has been obtained:

Particle size (x)	Sample Activity in Bq/g	
	<sup>238</sup> U	<sup>232</sup> Th
x<10 μm	0.04 ± 0.01	< 0,04
10 μm<x<53 μm	0.04 ± 0.01	< 0,04
53 μm<x<75 μm	0.04 ± 0.01	< 0,04
x>75 μm	0.05 ± 0.01	< 0,05

Uranium seems to be homogeneously distributed independent of the particle size, while thorium requires more sensitive analysis. Analysis of the Flosep separated respirable fraction is probably not required and data can be obtained from the bulk sample.

### 6.5. Slime

The slime sample showed a fine grain structure on visual inspection. The sample has been mechanically sieved, while the smallest particle fraction was separated using the Flosep separator. The following information on the distribution of NORM according to particle size has been obtained:

Particle size (x)	Sample Activity in Bq/g	
	<sup>238</sup> U	<sup>232</sup> Th
x<10 μm	2.27 ± 0.24	0.08 ± 0.01
10 μm<x<53 μm	1.18 ± 0.12	< 0,05
53 μm<x<75 μm	0.66 ± 0.07	< 0,03
x>75 μm	0.64 ± 0.07	0.04 ± 0.01

Uranium and thorium seem to be inhomogeneously distributed dependent on the particle size. Analyses of the Flosep separated respirable fraction will be required for proper risk evaluation.

### 6.6. Monazite

The monazite sample showed a fine grain structure on visual inspection. The sample has been mechanically sieved and the respirable fraction has been obtained by the Flosep separator. The following information on the distribution of NORM according to particle size has been obtained:

Particle size (x)	Sample Activity in Bq/g	
	<sup>238</sup> U	<sup>232</sup> Th
<10 μm	ND	ND
10 μm<x<53 μm	41.8 ± 5.78	106 ± 10
x>53 μm	28.0 ± 0.4	105 ± 10

Uranium seems to be inhomogeneously and thorium homogeneously distributed dependent on the particle size. Analyses of the Flosep separated respirable fraction will be required for proper risk evaluation.

## 7. NOTES

**7.1.** Laser diffraction, more correctly known as Low Angle Laser Light Scattering (LALLS), is now the method of choice for particle size analysis in many industries. Laser diffraction is an optical instrument in which a laser beam passes through a transparent cell containing the sample suspended in a liquid medium. The incident rays, which strike the particles, are scattered. The angles of scattering are inversely proportional to the size of the particles. The collector lens transforms the angular distribution of the scattered light to a spatial distribution in the focal plane of the lens,

**7.2.** Flosep Tube Systems are South African design patented world-wide. A Flosep tube is a centrifugal separation mechanism without any moving parts. The Flosep tube comprises of three elements, namely the vortex generator, the tube, and the mouthpiece. The functions of the parts are as follows:

- a The tube aligns the mouthpiece and vortex generator and forms the flow path for the airstream. There is a scavenge or waste opening in the tube through which the separated dust is ejected.
- b The vortex generator comprises of a number of blades. When gas enters the tube, the vortex generator induces swirls in the gas. Due to the resulting centrifugal force the particles migrate towards the wall of the tube.  
The Flosep tube operates with an inlet flow, a through flow and in some instances a bleed air or scavenge flow. When dust-laden air is extracted from the tube, it is called the bleed air or scavenge flow. The bleed airflow enhances the separation efficiency and is sometimes necessary to remove separated particles from the system. It should be emphasized that in this study the clean air fraction is sampled in order to separate the respirable dust from the bulk materials.

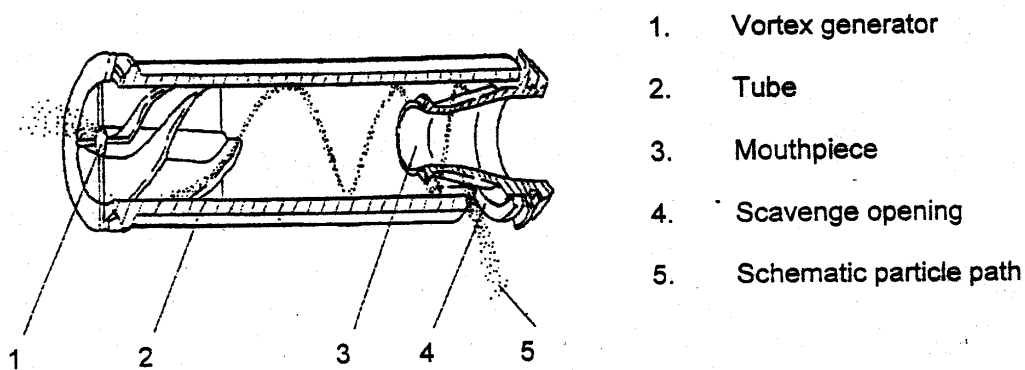

*FIG. 1. Flosep Tube System.*

## REFERENCES

- [1] BARTH, H.G., FLIPPEN, R.B., Particle size analysis, *Analytical Chemistry* **67**(12) (1995).
- [2] BARTON, T.P., ZIEMER, P.L., The effects of particle size and moisture content on the emanation of Rn from coal ash 50(5), *Health Physics* (1986) 581–588.
- [3] CHUNG, Y.S., CHUNG, Y.J., CHO, K.H., LEE, J.H., Determination of trace and toxic elements in Korean rice CRM by INAA, ICP and AAS, *Journal of Radioanalytical and Nuclear Chemistry* **215**(1) (1997) 129–134.
- [4] COHEN, H.J., POWERS, B.J., A study of respirable versus nonrespirable copper and zinc oxide exposures at a nonferrous foundry, *American Industrial Hygiene Association Journal*, **55**(11) (1994) 1047–1050.
- [5] DERBERTIN, K., HELMER, R.G., Gamma- and X ray spectrometry with semiconductor detectors, *Amerstardam-Lausanne-N.Y-Oxford-Shannon-Tokyo* (1988).
- [6] DISHMAN, K.L., DOOLIN, P.K., HOFFMAN, J.F., Comparison of particle size of cracking catalyst determined by laser light scattering and dry sieve methods, *Industrial Engineering Chemical Res* **32** (1993) 1457–1468.
- [7] DUGGAN, J.L., *Laboratory Investigations in Nuclear Science*, Tennelec, Oak Ridge, TN, USA (1998).
- [8] FRINDIK, O., VOLLMER, S., Particle-size dependent distribution of thorium and uranium isotopes in soil, *Journal of Radioanalytical and Nuclear Chemistry*, **241**(2), (1999) 291–296.
- [9] GILMORE, G., HEMINGWAY, J., *Practical Gamma Ray Spectrometry*, John Wiley and Sons-Chichester-New York-Brisbane-Toronto, Singapore (1996).
- [10] GROVES, W.A., HAHNE, R.M.A., LEVINE, S.P., SCHORK, M.A., A field comparison of respirable dust samplers, *American Industrial Hygiene Association Journal* **55**(8) (1994) 748–755.
- [11] HINDS, W.C., *Aerosol technology: properties, behaviour, and measurement of airborne particles*, John Wiley and sons, New York, Chichester, Toronto, Singapore (1982).
- [12] JOHNSTON, P.N., WILLIAMS, G.A., BURNS, P.A., COOPER, M.B., Plutonium resuspension and airborne dust loadings in the desert environment of Moralunga, South Australia, *Journal of Environmental Radioactivity* **20** (1993) 117–131.
- [13] KADWAD, V.B., JYOTSNA, N., SIVAPRASAD, N., SINHA, P.K., A method for preparation of magnetizable cellulose and its application in radioimmunoassays for T3 and T4, *Journal of Radioanalytical and Nuclear Chemistry Articles* **210**(1) (1996) 27–33.
- [14] KUMAR, A., IKEDA, Y., ABDOH, M.A., Experimental validation of radioactivity calculation for candidate fusion materials, *Journal of Nuclear Materials* **240** (1997) 144–153.
- [15] LANDA, E.R., Influence of ore type and milling process on Rn-222 emanation coefficients of U mill tailings, *Health Physics* **53**(6) (1987) 679–683.
- [16] LANDA, E.R., Radium-226 contents and Rn emanation coefficients of particle-size fractions of alkaline, acid and mixed U mill tailings, *Health Physics* **52**(3) (1987) 303–310.
- [17] LEESE, K.E., COLE, E.C., HALL, R.M., BERRY, M.A., Measurement of airborne and floor dusts in a nonproblem building, *American Industrial Hygiene Association Journal* **58** (1997) 432–438.
- [18] LIPPMANN, M., HARRIS, W.B., Size-selective samplers for estimating respirable dust concentrations, *Health Physics Pergamon Press* **8** (1962) 155–163.

- [19] LIPPMANN, M., ALBERT, R.E., The effect of particle size on the regional deposition of inhaled aerosols in the human respiratory tract, *American Industrial Hygiene Association Journal*, **28** (1969) 257–275.
- [20] LIPPMANN, M., KYDONIEUS, A., A multi-stage aerosol sampler for extended sampling intervals, *American Industrial Hygiene Association Journal*, **31** (1970) 730–738.
- [21] LIPPMANN, M., KYDONIEUS, A., Guide for respirable mass sampling, *American Industrial Hygiene Association Journal*, **31** (1970) 133–137.
- [22] Monazite, Microsoft (R) Encarta (R) 99 Encyclopedia ©, Microsoft corporation (1993–1998).
- [23] National Academy Press, Committee on evaluation of EPA guidelines for exposure to naturally occurring radioactive materials board on radiation effects, Research Commission on Life Sciences, National Research Council, Washington, DC (1999).
- [24] O'BRIEN, R.S., COOPER, M.B., Technologically enhanced naturally occurring radioactive material (NORM); pathway analysis and radiological impact, *Applied Radiation Isotope* **49**(3) (1998) 227–239.
- [25] ORR, C., DALLAVALLE, J. M., Fine particle measurement, Macmillan, New York (1960).
- [26] REIST, P., CREED, D., Use of sedimentation method for determining respirable mass fraction in a bulk dust sample, *American Industrial Hygiene Association Journal* **55**(7) (1994) 619–625.
- [27] SHAND, C.A., CHESHIRE, M.V., SMITH, S., Distribution of radiocaesium in organic soils, *Journal of Environmental Radioactivity* **23** (1994) 285–302.
- [28] SMIT, B., NECSA QA documentation: Measurement of radioactivity-radiometrics techniques- Document Reference: RA-TM-111 (1999).
- [29] SMIT, B., NECSA QA documentation: Measurement of radioactivity-radiometric techniques- Document Reference: RA-TM-112 (1999).
- [30] TERRENCE, A., Particle size measurement, Macmillan, New York (1968).

## APPENDIX

<http://as.wm.edu/Nondestructive.html>  
<http://www.physics.isu.edu/radinf/natural.html>  
<http://www.malvern.co.uk/Laboratory/psintro.html>  
<http://www.malvern.co.uk/news 2000.html>  
<http://www.malvern.co.uk/Laboratory/master.html>  
[http://www.micrometrics.com/ps\\_elzone\\_al.html](http://www.micrometrics.com/ps_elzone_al.html)  
[http://www.micrometrics.com/ps\\_elzone\\_at.html](http://www.micrometrics.com/ps_elzone_at.html)  
<http://www.malvern.co.uk/Laboratory/2000prod.htm>  
[http://www.micrometrics.com/ps\\_elzone.html](http://www.micrometrics.com/ps_elzone.html)  
<http://www.micrometrics.com/particlesize.html>  
[http://search.knowledgestor.com/info/com\\_aphet\\_jcrs\\_jcrs\\_1994\\_1058.html](http://search.knowledgestor.com/info/com_aphet_jcrs_jcrs_1994_1058.html)  
<http://www.lavallab.com/eng/particle-size.htm>



## PARTICIPANTS IN THE COORDINATED RESEARCH PROJECT

### **Brazil**

Maria A. de B.C. Menezes  
Centro de Desenvolvimento da Tecnologia Nucl.  
Comissão Nacional de Energia Nuclear  
Rua Prof. Mario Werneck, s/n  
Caixa Postal 941, CEP 30123-970  
Belo Horizonte, Minas Gerais  
Brazil  
Tel: +55-31-349 93 253  
Fax: +55-31-349 93 380  
E-mail: menezes@urano.cdtm.br

### **China**

Zhifang Chai  
Department of Nuclear Analysis  
Institute of High Energy Physics  
Academia Sinica  
P.O. Box 2732  
Beijing 100080  
China  
Tel: +86-10-625 63 339 ext. 4205 or  
+86-10-648 78 438 (direct)  
Fax: +86-10-625 73 660  
E-mail: chaizf@lnat.ihepa.ac.cn

### **Czech Republic**

J. Kučera  
Nuclear Spectroscopy Department  
Nuclear Physics Institute  
Academy of Sciences of the Czech Republic  
CZ-25068 Rez near Prague  
Czech Republic  
Tel: +420-2-661 72 268  
Fax: +420-2-209 41 130  
E-mail: kucera@ujf.cas.cz

### **Denmark**

J.M. Christensen  
Department of Environmental Chemistry  
National Environmental Research Institute  
Frederiksborgvej 399  
DK-4000 Roskilde  
Denmark  
Tel. +45-46-30 12 00 or  
+45-46-30 13 50 (direct)  
Fax: +45-46-30 11 14  
E-mail: jmc@dmu.dk



- India**  
P.M.B. Pillai  
Health Physics Unit  
Indian Rare Earths Ltd.  
Udyogamandal  
Kerala, 683 501  
India  
Tel: +91-484 54 5062 (4 lines), 484 54 5767 (direct)  
Fax: +91-484 54 5269  
E-mail: irered@vsnl.com
- Indonesia**  
Harjoto Djojosebroto  
National Nuclear Energy Agency (BATAN)  
Instrumentation and Radiometric Analysis Division  
Nuclear Technique Research Center  
Jalan Tamansari No. 71  
Bandung 40132  
Indonesia  
Tel: +62-22-250 3997 ext. 711  
Fax: +62-22-250 40 81  
E-mail: helia@attglobal.net
- Kenya**  
A.M. Kinyua  
Institute for Nuclear Science, College of Engineering  
University of Nairobi  
P.O. Box 30197, Nairobi  
Kenya  
Tel: +254-2-334 244 Exts. 28483/28536 or  
+254-2-57 37 15/24  
Fax: +254-2-336 885 or 214 912  
E-mail: antonykinyua@hotmail.com
- Portugal**  
T. Pinheiro  
Physics Department  
Nuclear and Technological Institute  
Estrada Nacional 10  
P-2685 Sacavem  
Portugal  
Tel: +351-21-994 6000 (21-994 6250 direct)  
Fax: +351-21-994 15 25  
E-mail: murmur@int1.itn.pt
- Russian Federation**  
M.V. Frontasyeva  
Dept. of Activation Analysis and Radiation Research,  
Frank Laboratory of Neutron Physics  
Joint Institute for Nuclear Research  
141980 Dubna, Moscow Region  
Russian Federation  
Tel: +7-095-924 39 14 or +7-09621-65609 (direct)  
Fax: +7-09621-65085  
E-mail: marina@nf.jinr.ru

**Slovenia**

R. Jačimovič  
Laboratory for Radiochemistry  
Department of Environmental Sciences  
Institut Jožef Stefan  
Jamova 39 - SI-1111 Ljubljana  
Slovenia  
Tel: +386-1-5885-353  
Fax: +386-1-5885-346  
E-mail: radojko.jacimovic@ijs.si

**South Africa**

A. Faanhof  
South African Nuclear Energy Corporation (NECSA)  
P.O. Box 582  
Pretoria 0001  
South Africa  
Tel: +27-12-305 52 35  
Fax: +27-12-305 59 44 or +27-12-668 19 47  
E-mail: afaanhof@aec.co.za

**IAEA**

B. Smodiš  
International Atomic Energy Agency  
Department of Nuclear Sciences and Applications  
Division of Human Health  
Nutritional and Health-Related Environmental Studies Section  
P.O. Box 100  
A-1400 Vienna