



UNIVERSITY OF NAIROBI
HOUSING RESEARCH AND DEVELOPMENT UNIT

UNIVERSITY OF NAIROBI
ADD LIBRARY

BUILDING EXPERIMENTS WITH PRECAST
CONCRETE ELEMENTS IN NAIROBI

a case study of two experimental housing
schemes executed by Nairobi City Council
in 1969-72

Author: Finn/Olesen
Research Fellow

Date: July 1979

Housing Research and Development Unit - HRDU
Director - T.S. Chana
P.O. Box 30197 Nairobi, Tel. 27441, ext. 212.

| <u>TABLE OF CONTENTS</u> | <u>PAGE</u> |
|--|-------------|
| 1. INTRODUCTION | 5 |
| 2. UHURU PHASE IV | 8 |
| 3. PRE-CASTING YARD UHURU PHASE IV | 11 |
| 4. PRE-CASTING YARD JUJA ROAD | 19 |
| 5. MOULD CONSTRUCTION AND MAINTAINING | 25 |
| 6. PREPARING AND PLACING OF REINFORCEMENT | 27 |
| 7. CONCRETE MIXING AND CASTING OF ELEMENTS | 29 |
| 8. HARDENING AND STAKING OF ELEMENTS | 31 |
| 9. TRANSPORT OF ELEMENTS ON SITE | 33 |
| 10. ERECTION OF THE ELEMENTS | 35 |
| 11. CONCLUSIONS | 46 |
| 12. USER REACTION AND BUILDING PERFORMANCE SURVEY, UHURU | 48 |
| 13. SUMMARY OF CONCLUSIONS | 49 |

Add
Afr.
HD
7374
K40
c.2

INTRODUCTION

This report is a case study of two experimental housing schemes, Uhuru Phase IV and Juja Road Development Scheme Phase I, which was executed by the Nairobi City Council during the years of 1969-72. The aim of this report is to describe the building system used and to accumulate the knowledge and experience obtained to make it accessible as background material for future building experiments of this kind.

During the years up to 1972-73, the Nairobi City Council has planned and built, by direct labour and by contractors, a large number of houses throughout the city mainly for the medium income groups.

From the beginning of the sixties, the Nairobi City Council started planning and building low-income houses in a big scale by contractors and by direct labours.

In 1969, Uhuru Phase IV, a one and two storey housing scheme, was planned as an experimental scheme using precast reinforced concrete elements cast on site for construction.

The aim of this project was to gain experience with the process of building houses with on-site precast concrete elements by an ordinary labour-force for establishing of a high quality of construction and a speedy building process for future housing schemes.

Uhuru Phase IV was completed in September 1971, and it was decided to set up a new pre-casting yard at Mathare Valley.

The Mathare Core Housing Scheme Phase I, a conventionally built housing scheme using concrete blocks, was already in progress and the

idea was to build the same core-house type in precast concrete elements, and to compare the core-houses in terms of cost, quality and time spent on construction.

In December 1971, the new precasting yard and building site (now known as Juja Road Development Scheme Phase I, consisting of 400 units) was in full operation, and the first eight houses were erected as demonstration houses and used as offices. During the next two months, 28 houses were erected, and a large number of foundations were under progress. Then the whole scheme, both the conventionally built houses and the precast houses, were stopped for unstated reasons.

The closing of the two building sites stopped the precast building experiment.

Later, the eight houses used as offices were pulled down to give space for a high-rise housing scheme. The precast yard was demolished, and moulds and elements were moved to a dumping place where they are still lying.

This report contains drawings of the house types built and the various elements used at the two housing schemes mentioned as well as a description of the procedure of casting and erection of the elements.

The conclusions and information in this report are based on the author's personal experience, having been in charge of the experiment for nine months, readily accessible information from City Council of Nairobi and a user reaction and building performance survey carried out at Uhuru Phase IV during February 1979.

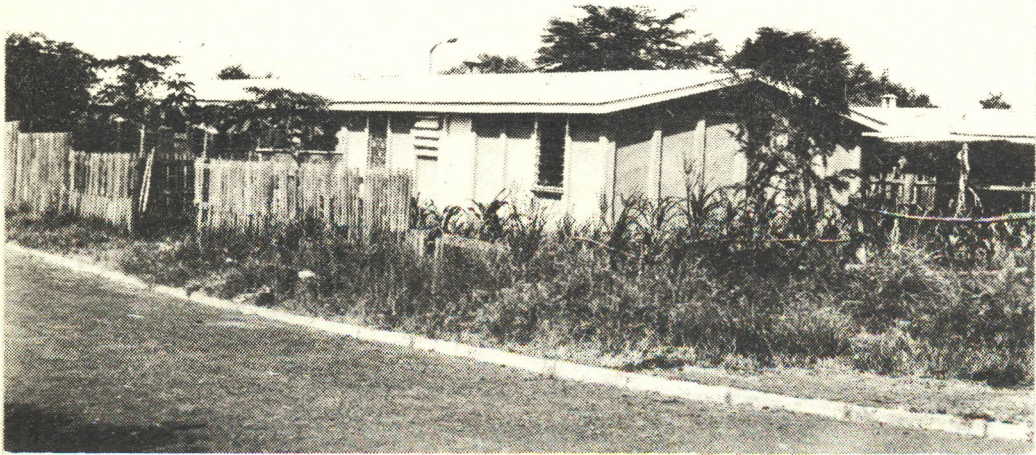

ONE STOREY HOUSE, UHURU PHASE IV
SOURCE: THE AUTHOR

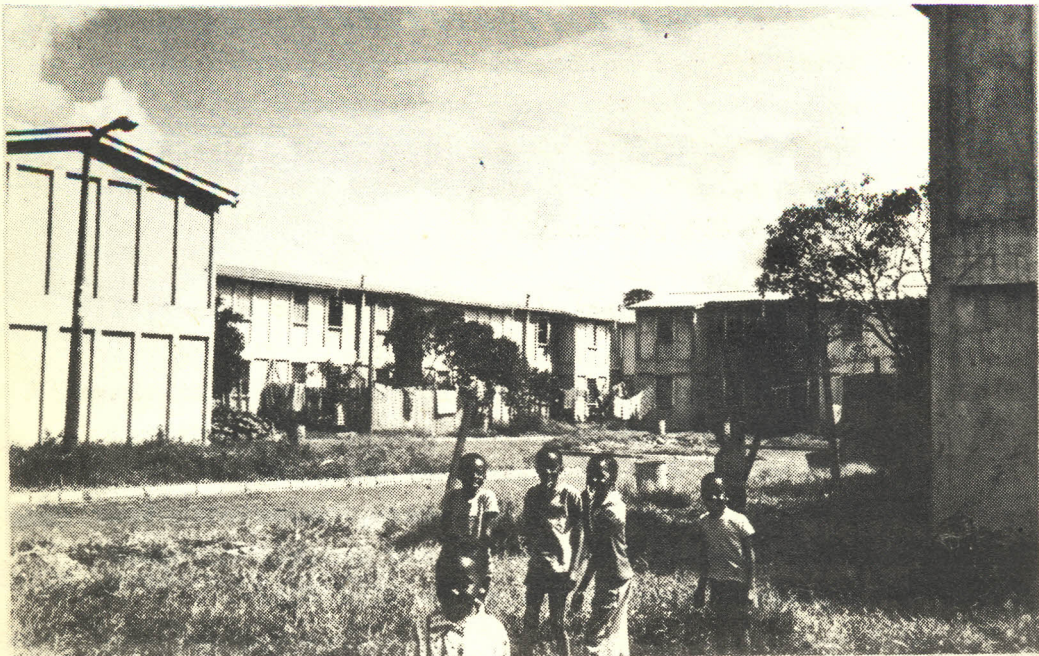

TWO STOREY HOUSES, UHURU PHASE IV
SOURCE: THE AUTHOR

UHURU PHASE IV

Uhuru Phase IV housing scheme was completed in September 1971.

The scheme consists of 228 single storey and 66 double storey houses.

The planning of the scheme and the design of the houses was done by the Nairobi City Council and built by direct labour.

The scheme was implemented as building experiment with precast reinforced concrete elements, cast on site and erected by a mixed gang of unskilled and skilled labour under supervision of a resident engineer.

The whole scheme was calculated to cost K£268,000, but no Bill of Quantities was prepared, and the estimates were rough approximations.

When the scheme was completed in September 1971 the total cost came to K£348,000.

This figure resulted from underestimating and K£73,000 of extra work.

The final cost of a single storey house came to KShs.22 - per sq.ft. of floor area which added up to KShs.10,450 for a three roomed house.

The cost of a two storey house came to KShs.25 - per sq. ft. floor area which added up to KShs. KShs.16,250 per unit.

To cover the cost of the scheme, the houses were sold on a tenant purchase basis.



The sale price for a one storey house with three rooms came to KShs.22,000 and monthly mortgage repayments over 20 years are KShs.163/-.

The sale price for a two storey house with four rooms came to KShs.28,000 and monthly mortgage repayment over 20 years are KShs.208/-.

LAYOUT PLAN

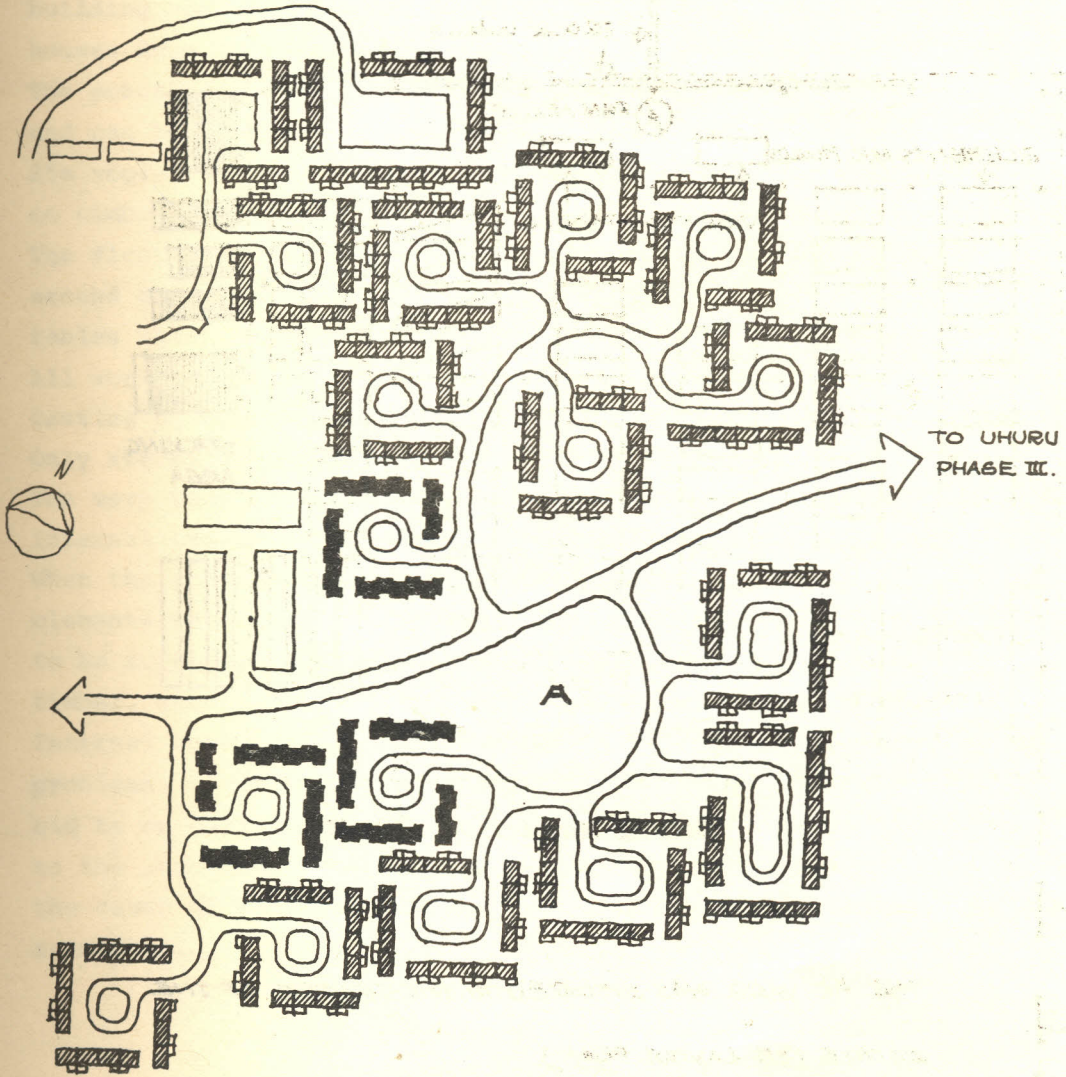
UHURU PHASE IV.



-  ONE STOREY BUILDINGS
-  TWO STOREY BUILDINGS
-  EXISTING BUILDINGS
- A** SITE FOR PRE-CASTING YARD

THE LAYOUT OF THE PRE-CASTING YARD, UHURU PHASE IV.

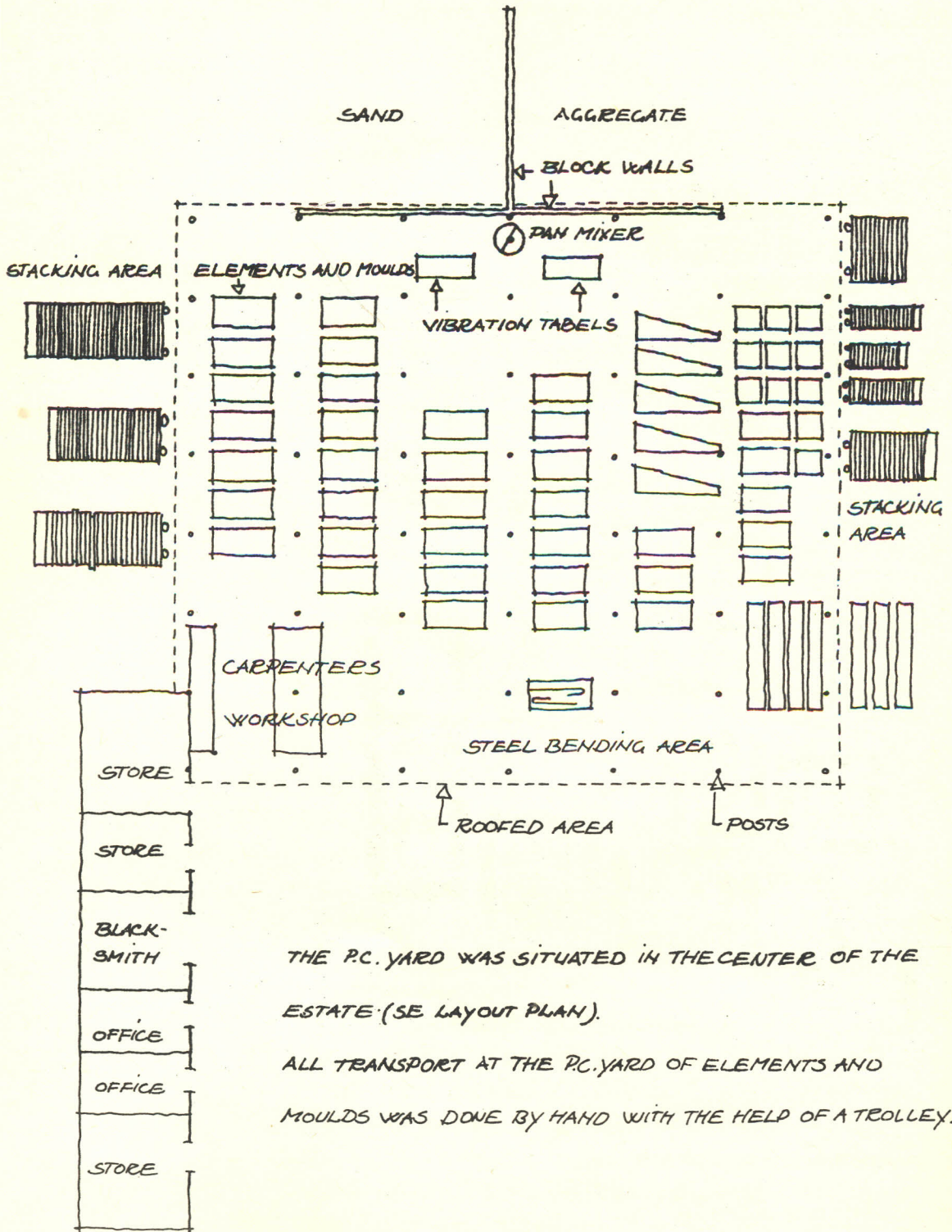

PRECASTING YARD UHURU PHASE IV

The precasting yard was situated in the centre of the housing scheme, and all the concrete building components used to construct the houses were cast at this yard.

The precasting yard had a very simple layout and can be described as an area of about 22m by 25m roofed with corrugated iron sheets erected on timber purlins and posts.

The floor was just rammed earth except for an area around the concrete mixer and the vibration tables which was of concrete.

All work, mould making, steel bending and casting of elements was done under this roof.

Only stacking of elements was done outside.

The very rough floor caused problems with internal transport of moulds and elements.

When the concrete filled moulds and the elements were placed on the ground, they had to be supported and kept level with pieces of timber, stones or whatever was at hand.

Internal movement of elements gave a lot of problems. Due to lack of space, the elements had to be carried by hand across other elements to the stacking area, and this operation was the cause of many elements getting cracks and scratches.

TYPE PLAN, ONE STOREY HOUSE, UHURU PHASE IV.

THREE ROOMED HOUSE, PLINT AREA: 49m^2 , HABITABLE AREA: 26.73m^2

CONTAINING: TWO BED ROOMS, ONE LIVING ROOM, KITCHEN, TOILET, SHOWER, STORE, HALL AND A OPEN COURT YARD.

NUMBER OF ELEMENTS USED TO MAKE ONE UNIT: (SEMI-DETACHED)

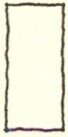

MAIN WALL ELEMENTS: 37

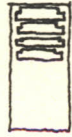

VENTILATION ELEMENTS: 3



SMALL ELEMENT UNDER WINDOWS: 4

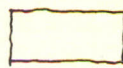

DOUBLE RIDGE ELEMENTS: 3



GABLE ELEMENTS: 7



SINGLE RIDGE ELEMENT: 1



KITCHEN SLABS: 1

TOTAL NUMBER OF ELEMENTS: 62

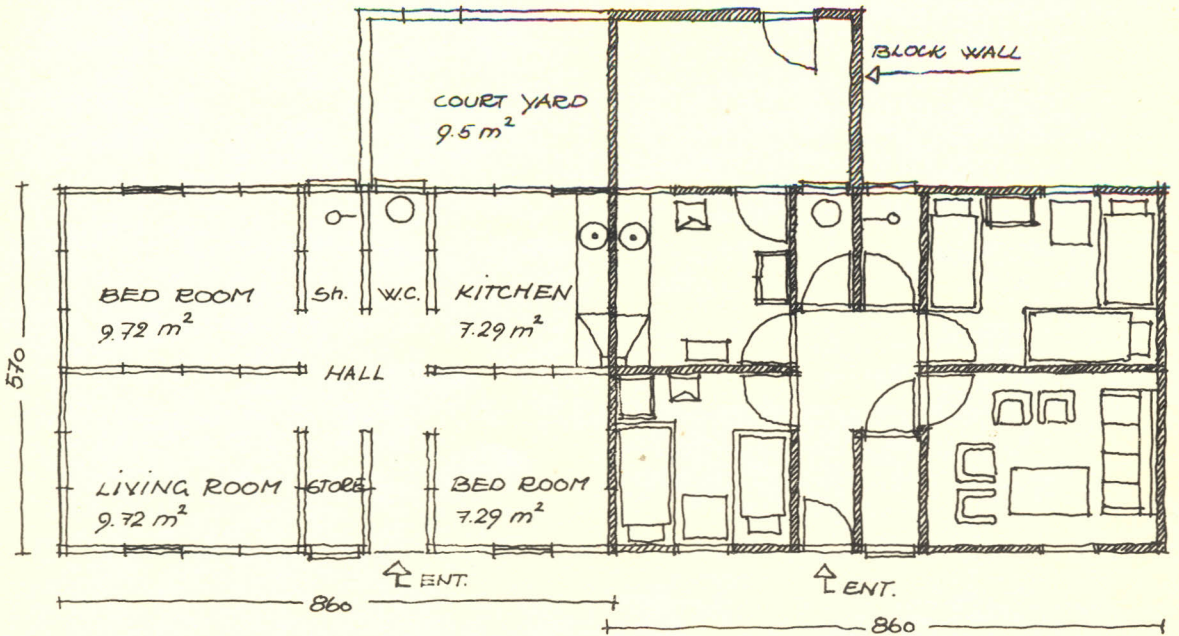

GROUND PLAN

ELEVATIONS, THREE ROOMED HOUSE, UHURU PHASE IV.

FRONT ELEVATION

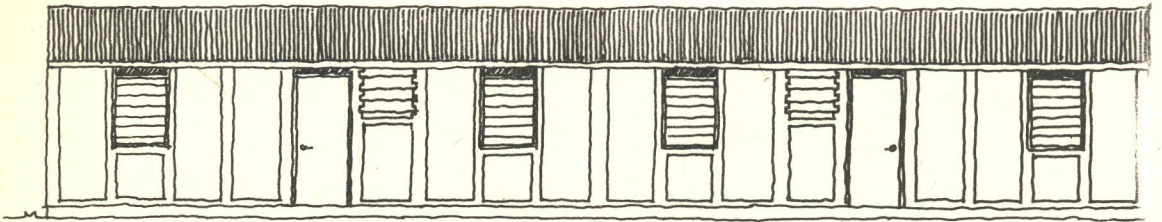

+ THREE ROOM, KITCHEN, W.C., STORE AND SHOWER +

ONE UNIT

+

BACK ELEVATION

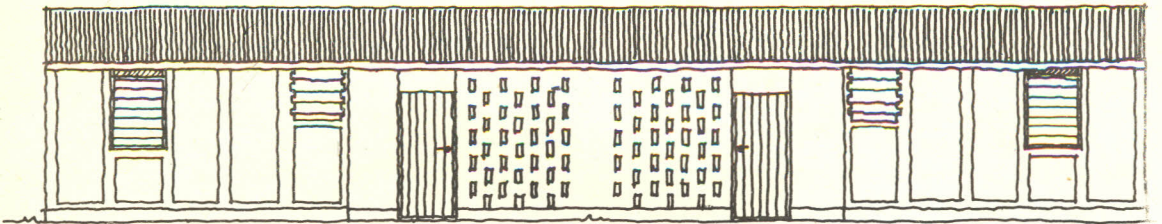

+ ROOM + W.C. + COURT YARD + COURT YARD + W.C. + ROOM +

FRONT ELEVATION

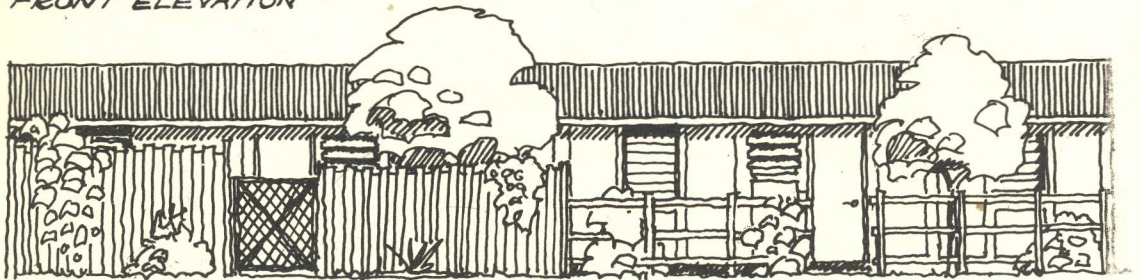

ALL HOUSES HAVE A FRONT GARDEN

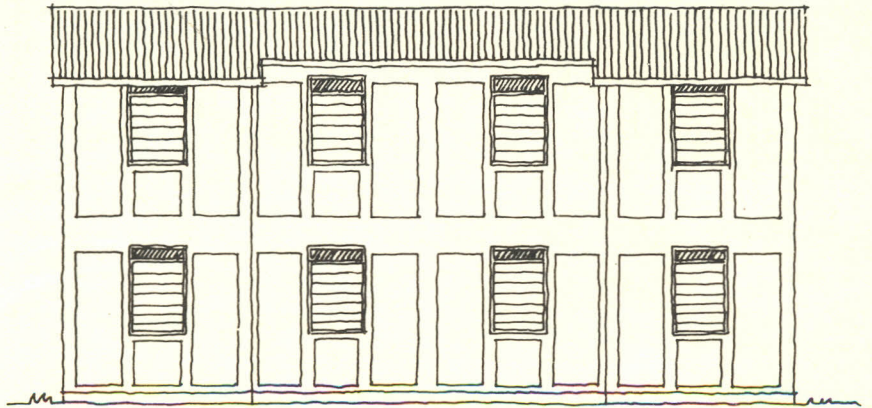
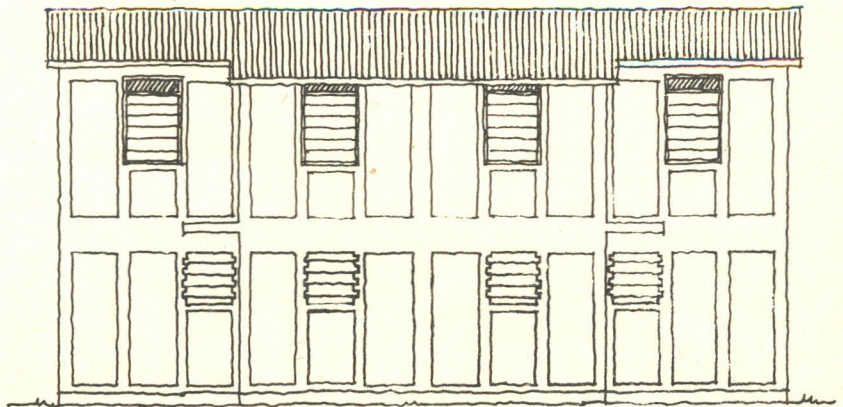
ELEVATIONS, TWO STOREY HOUSE, UHURU PHASE IV.FRONT ELEVATIONBACK ELEVATION

TYPE PLAN, TWO STOREY HOUSE, UHURU PHASE IV

FOUR ROOMED HOUSE, PLINTH AREA: $32,2m^2$, HABITABLE AREA: $33,12m^2$

CONTAINING: THREE BED ROOMS, ONE LIVING ROOM, KITCHEN, SHOWER, W.C. AND A STORE.

NUMBER OF ELEMENTS USED TO MAKE ONE UNIT (SEMI-DETACHED)

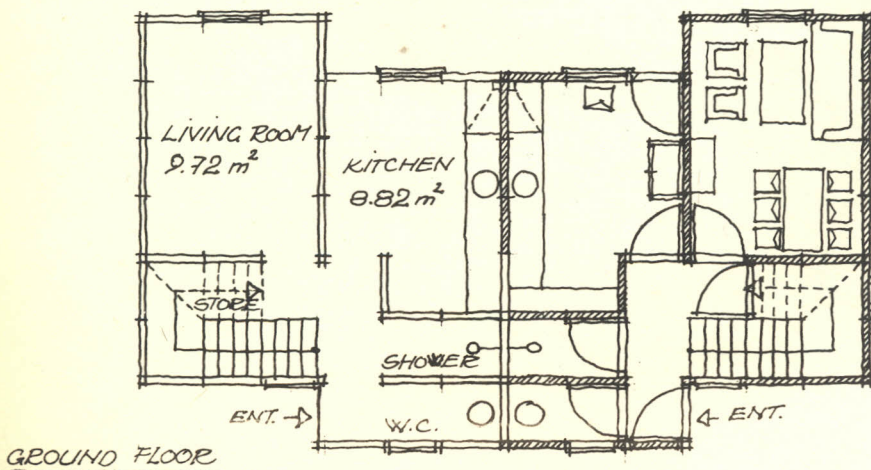
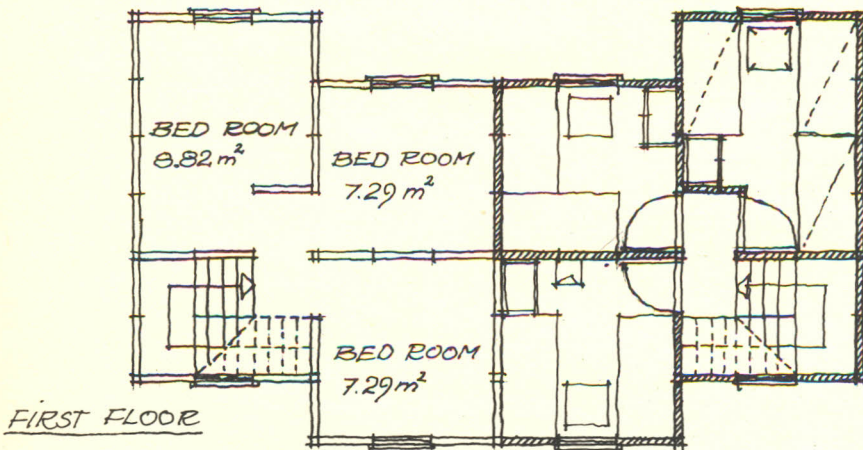
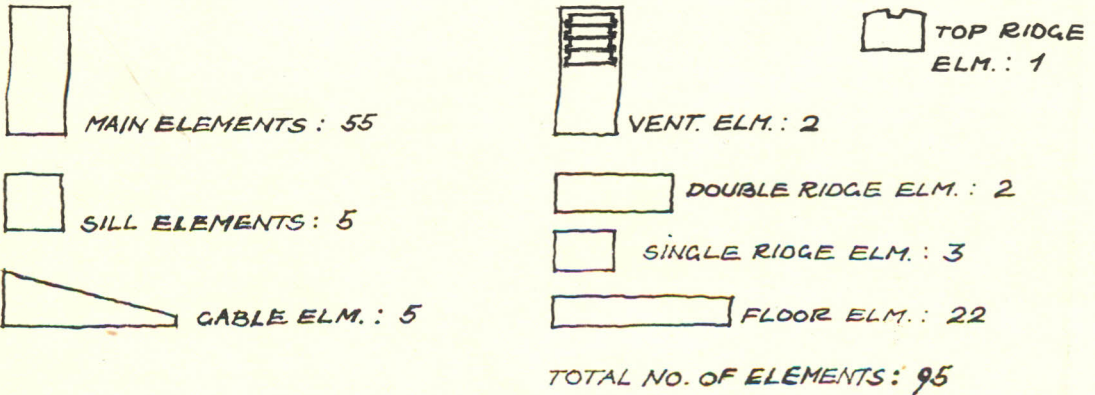

ERECTION OF ELEMENTS, TWO STOREY BUILDINGS

UHURU PHASE IV.

SCALE 1:100

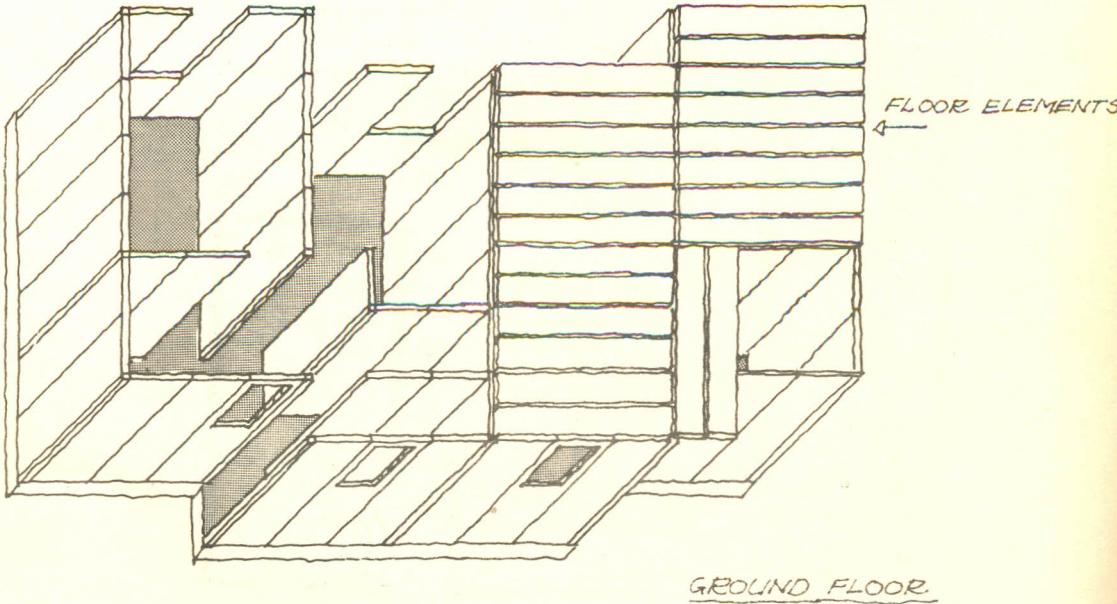
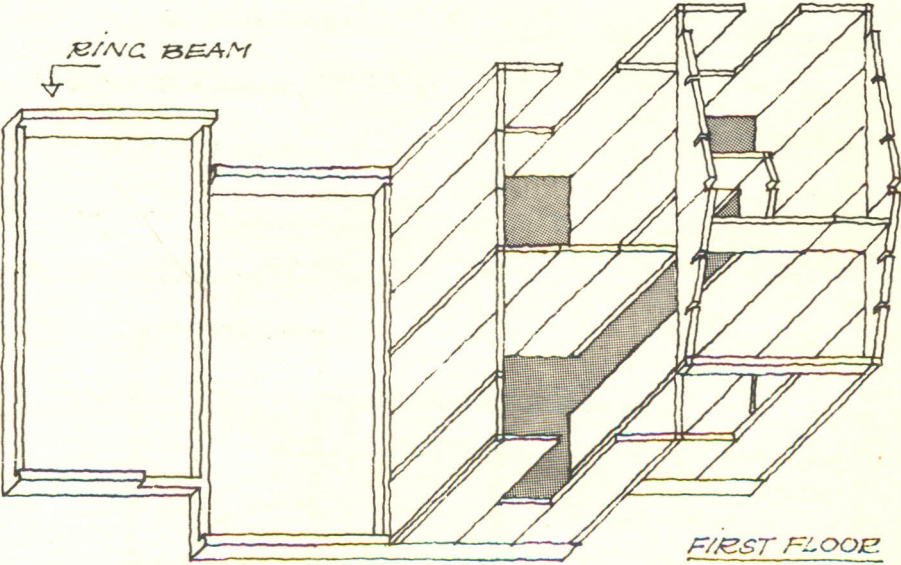



TWO STOREY HOUSES, UHURU PHASE IV
SOURCE: THE AUTHOR



TWO STOREY HOUSES, UHURU PHASE IV
SOURCE: THE AUTHOR

LAYOUT PLAN.

JUJA ROAD DEVELOPMENT SCHEME PHASE I.

A,  ERECTED BUILDINGS - PRE-CAST CONCRETE ELEMENTS.

D, BLOCK D IS BUILT IN TRADITIONAL BLOCK WORKS.

C-B, THE SITES ARE NOW OCCUPIED BY TWO AND FIVE STOREY BUILDINGS.

(IN BLOCK A, ONLY THE 28 PRECAST HOUSES ARE ERECTED).

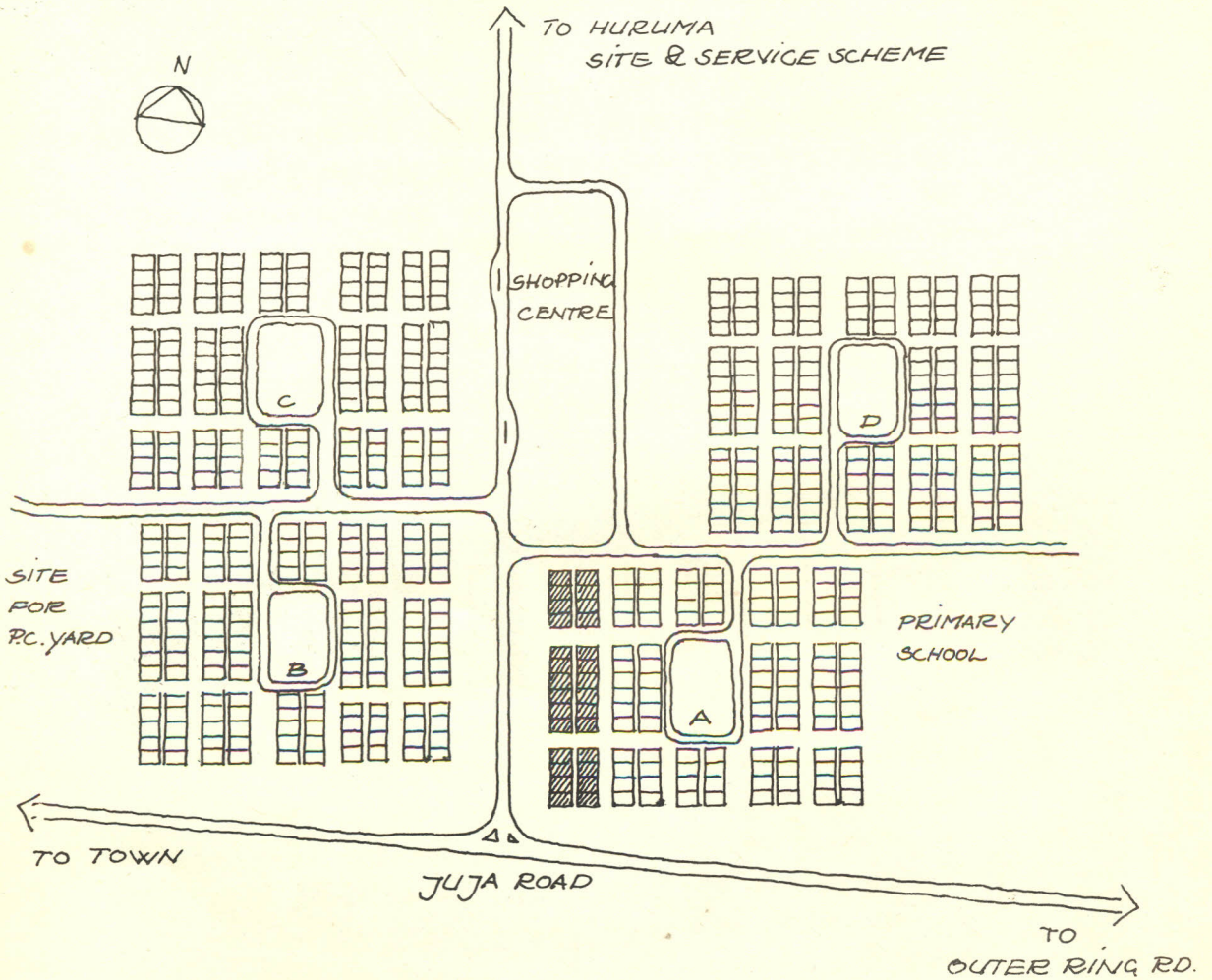

PRECASTING YARD, JUJA ROAD

The set up of the precasting yard at Juja Road took place during August and September 1971. Following the plans, the new yard should have produced elements for at least 400 three-roomed houses on site, as well as nursery schools, workshops and some community buildings.

Taking this into account, the precasting yard was planned carefully and was a lot more sophisticated than the old one at Uhuru Phase IV.

Three vibration tables were established.

A pair of trolley rails run from each table through the whole yard and out to the stacking area. The rails were mounted on one course of concrete blocks on the same level.

The filled moulds were transported on the trolleys and placed on the rails for hardening.

The three rails enabled the yard to maintain a continuous working procedure thus making the utilisation of the facilities as efficient as possible. The filled moulds were given $2\frac{1}{2}$ -3 days to harden before they were disassembled and the element was moved by the trolley to the stacking area.

Starting the first day, the first rail was filled with one day's production of main elements and the same day the moulds and elements were removed from the second rail.

The next day the second rail, now empty, was filled and the third rail emptied and so on.

(The drawing on page 21 shows the situation on the third day at the yard).

The introduction of the rails and the trolleys was a tremendous achievement to the working procedure. The work of lifting the filled moulds was reduced to two small operations of lifting the moulds from the vibration table down to the trolley and again from the trolley to the rails.

Lying on the rails, the moulds were at a good working height for smoothing the surface and for the work of disassembling the moulds. The daily production was 41-46 main elements and 19-23 smaller elements, which were the numbers required for construction of one three-roomed house.

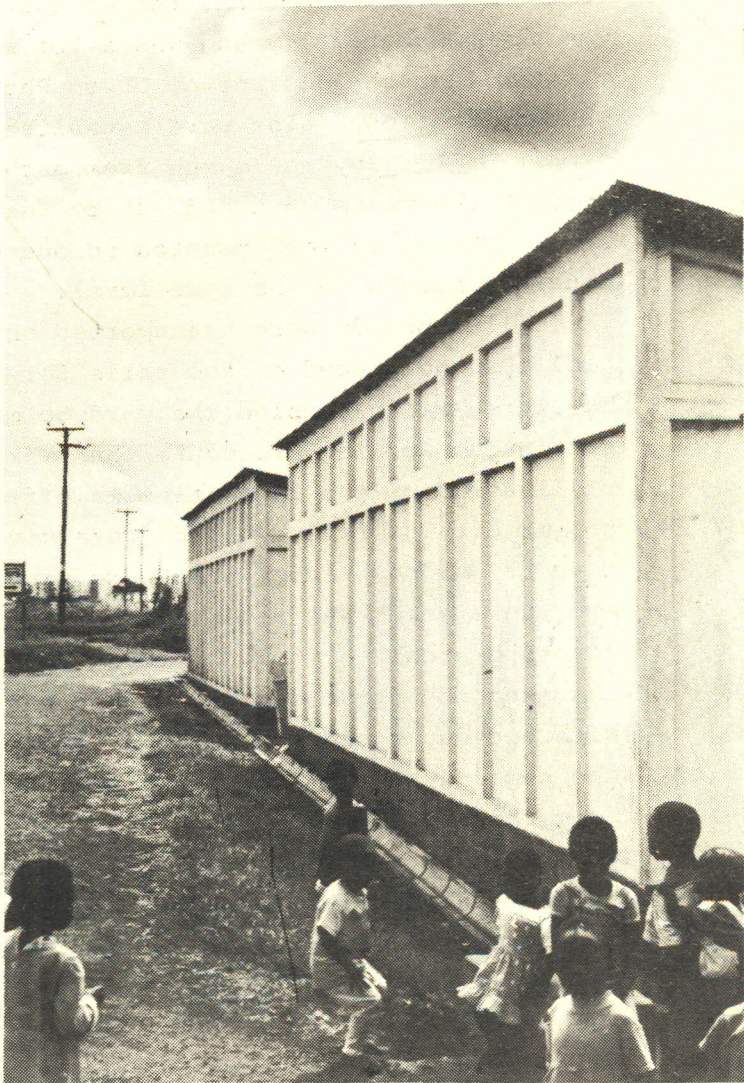
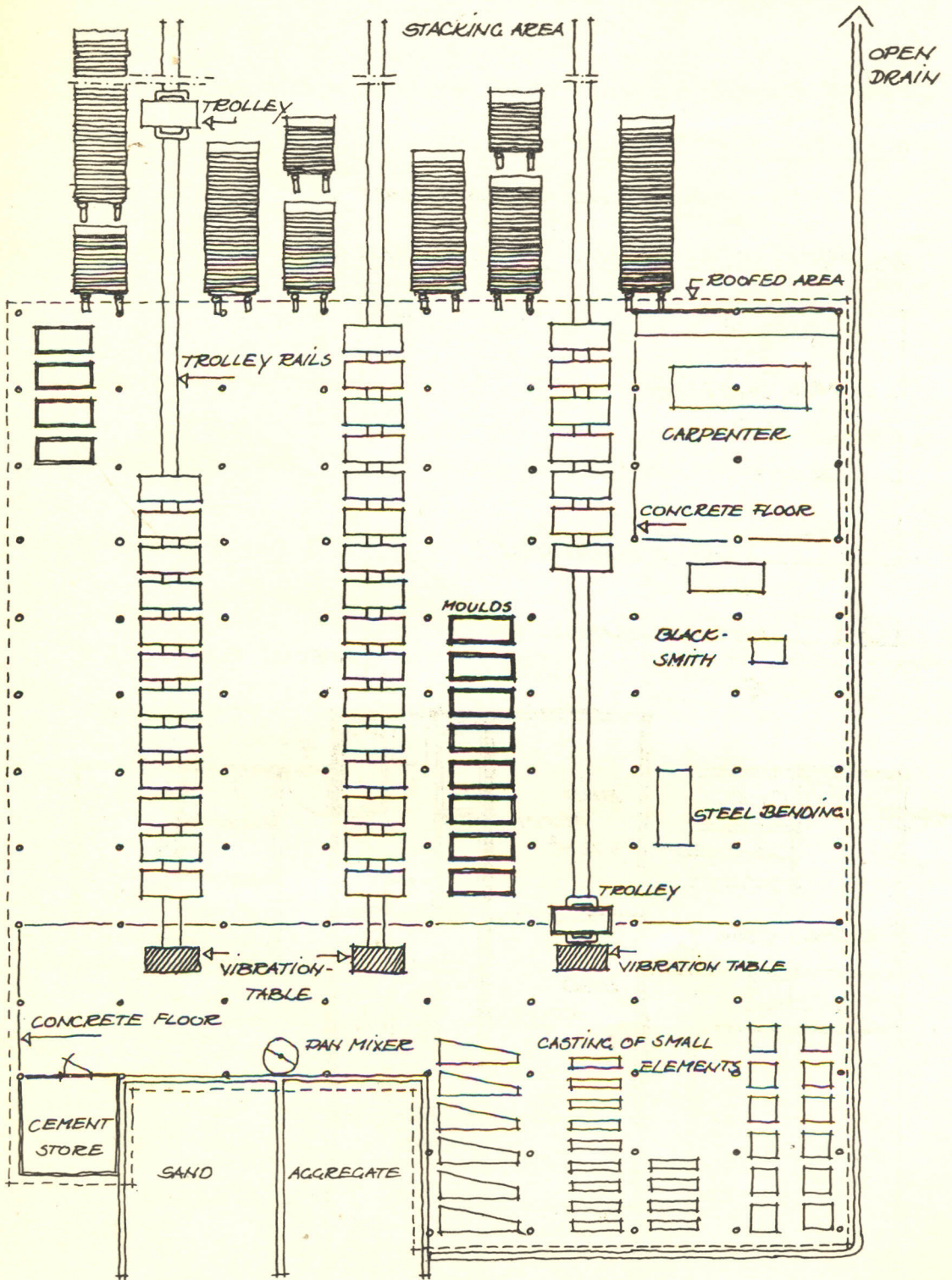

Photo: Juja Road Development Scheme
Source: The author

THE LAYOUT OF THE PRE-CASTING YARD, JUJA RD. DEVELOPMENT
SCHEME PHASE II.







TYPE PLAN, THREE ROOMED HOUSE, JUJA ROAD DEVELOPMENT

SCHEME PHASE I.

THREE ROOMED HOUSE, PLINTH AREA: 49.6m², HABITABLE AREA: 29.16m²

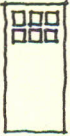
CONTAINING: TWO BED ROOMS, ONE LIVING ROOM, KITCHEN, SHOWER, TOILET AND A OPEN COURT YARD.

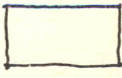
NUMBER OF ELEMENTS USED TO MAKE ONE UNIT, (SEMI-DETACHED).

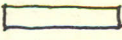
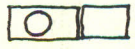
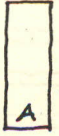
-  MAIN WALL ELEMENTS: 37
-  VENTILATION ELEMENTS: 4
-  ELEMENT UNDER WINDOWS: 4
-  TOP RIDGE ELEMENTS: 3
-  GABLE ELEMENTS: 4
-  RIDGE ELEMENTS: 6
-  KITCHEN SLABS: 1
-  SPECIAL ELEMENT: 1

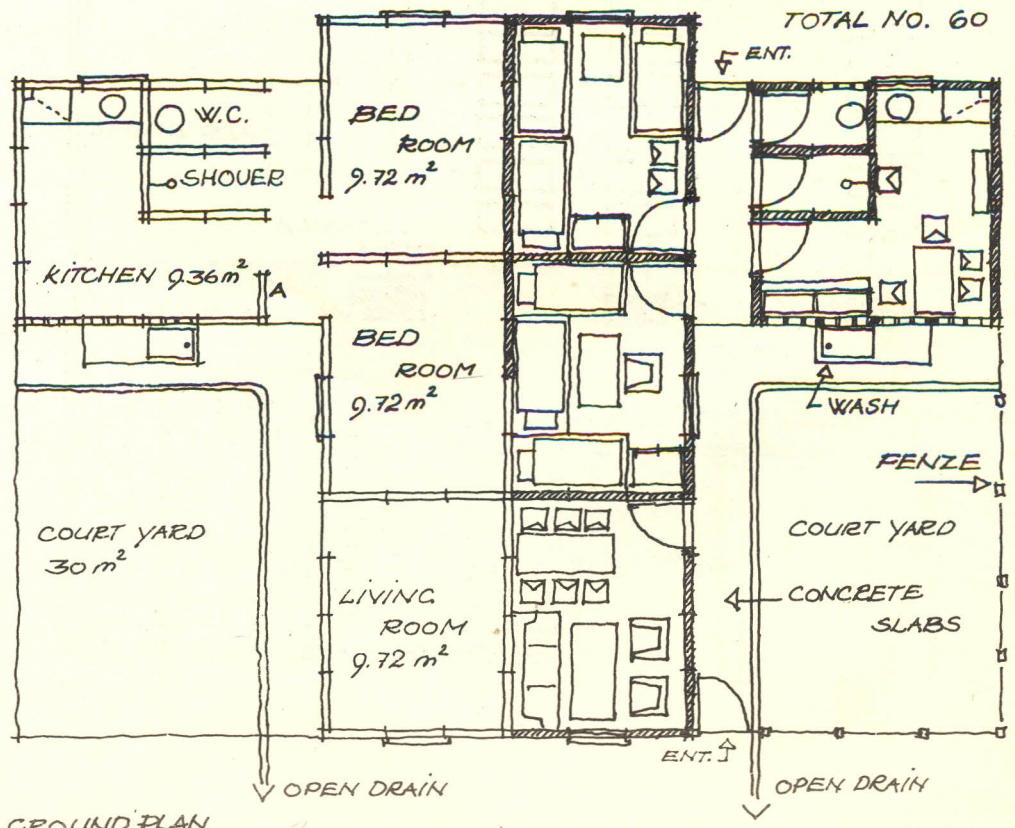

GROUND PLAN

ELEVATIONS, THREE ROOMED HOUSE, JUJA ROAD DEVELOPMENT SCHEME PHASE I.

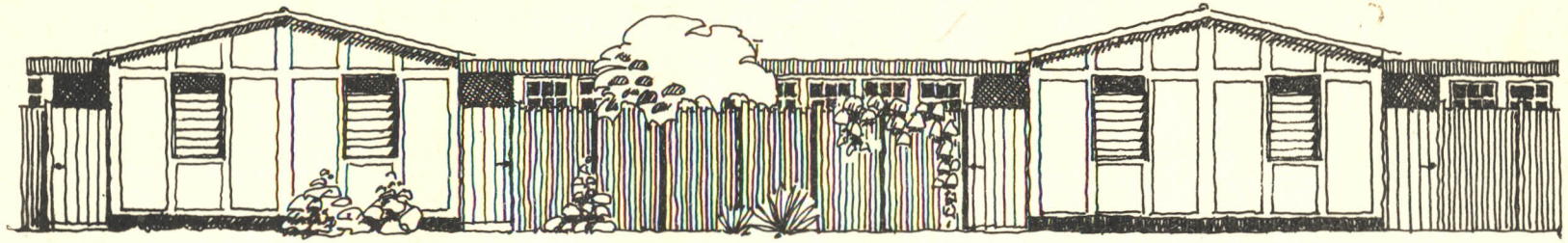

ONE UNIT ONE UNIT
(THREE ROOMS, KITCHEN, W.C., SHOWER)

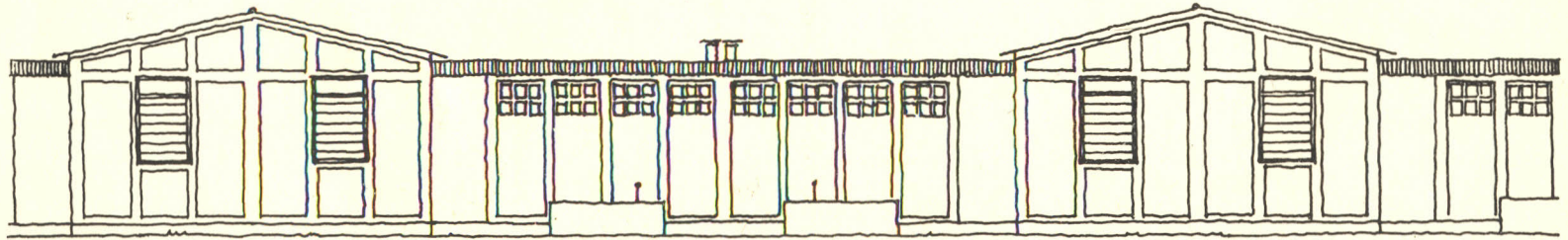

+ ROOMS + PASSAGE + WET CORE + WET CORE + PASSAGE + ROOMS +
WASH WASH

MOULD FOR MAIN ELEMENT

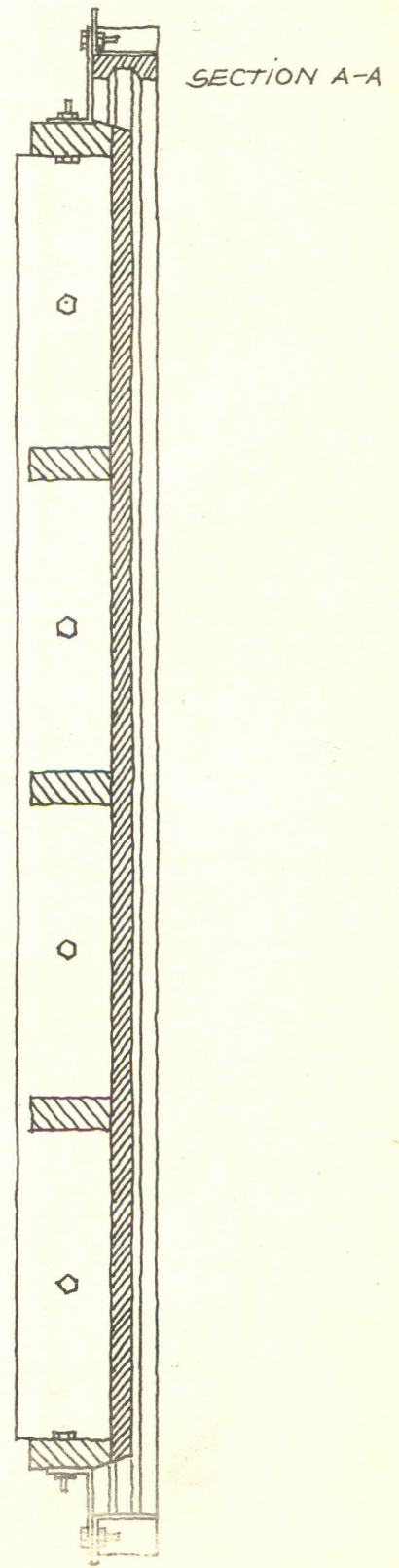
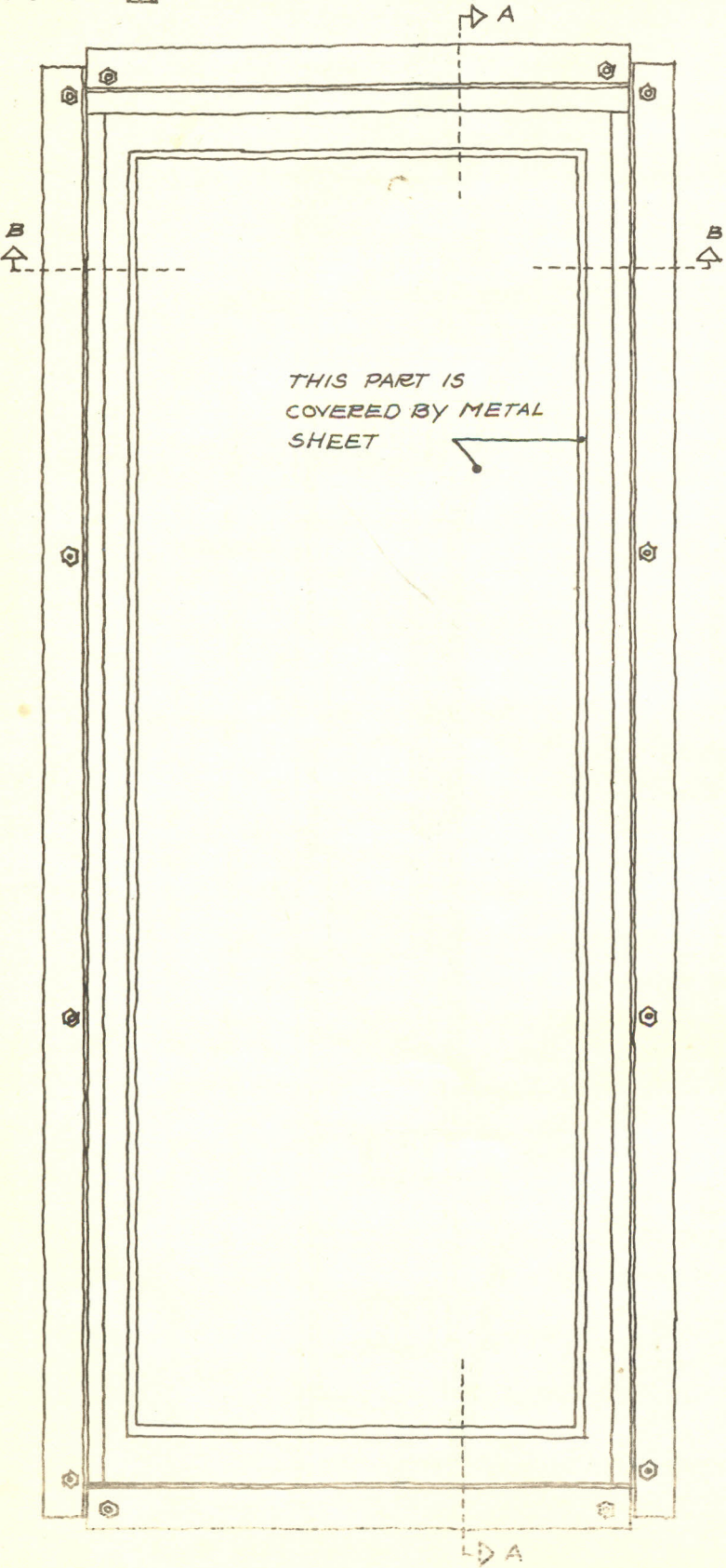
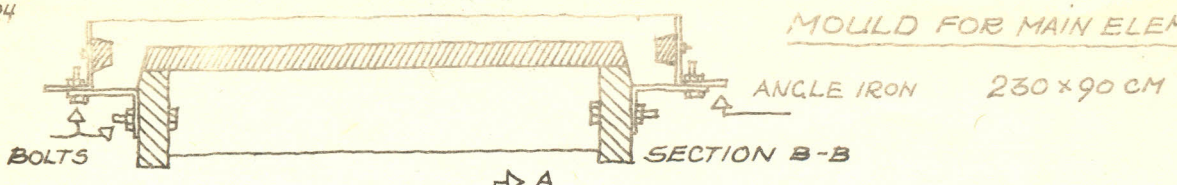

MOULD CONSTRUCTION AND MAINTENANCE

Mould making according to drawings proved to be a difficult task for the carpenters.

When one mould was completed however, the rest were no problem, since there was now one to look at and to measure. Maintaining moulds needed constant attention which proved no problem other than looking out for the moulds which needed to be adjusted to measurement before use.

The heavy angle steel profile which was a part of the mould construction helped to strengthen the timber mould when filled with concrete. However, due to vibration the holes through which the steel was bolted to the timber bottom gradually became too big and the steel frame went out of measure and had to be adjusted.

When the housing scheme, and the precasting yard, was closed down in April 1972, many of the moulds which were made back in 1969 were still in use. Especially the smaller moulds appear to have had a long time of service.

Conclusions: Timber moulds need constant care in handling. The maintenance and building of timber moulds requires very skilled craftsmen. Supervision has to be restricted to capable personnel. Moulds constructed of steel are recommended for future experiments especially if working with unskilled labourers.

ELEMENT DRAWINGS

ON THE FOLLOWING PAGES, SKETCHES OF 15 ELEMENTS ARE SHOWN WITH PLACING OF REINFORCEMENT.

THE CONCRETE MIX USED WAS 1:3:4

THE BALLAST USED WAS $\frac{1}{2}'' + \frac{3}{8}''$ CRUSHED GRANITE MIXED.

SILL ELEMENT, USED AT UHURU PHASE IV AND JUJA ROAD

DEVELOPMENT SCHEME.

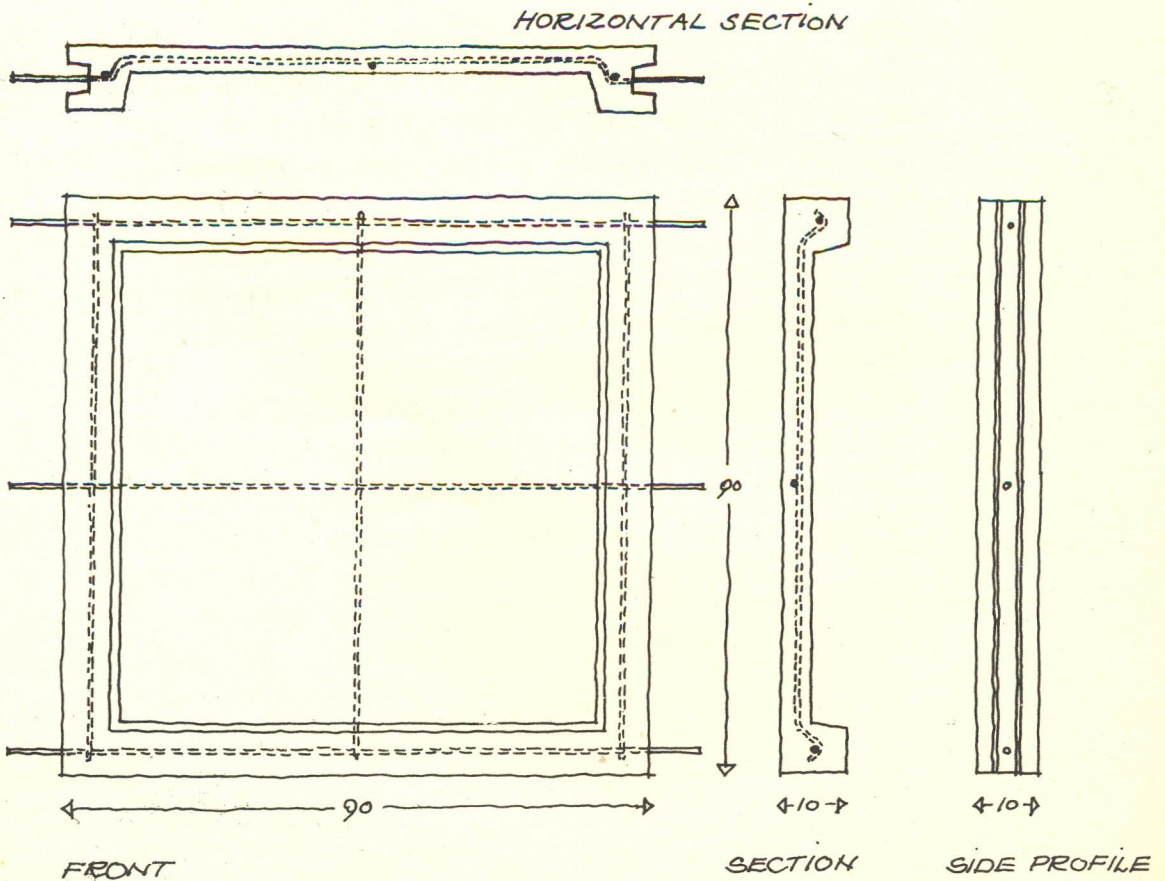

PREPARING AND PLACING OF REINFORCEMENT

Producing panels of a thickness of 40 mm, reinforced by 6 mm iron bars in two directions leaves only a little tolerance for misplacement of the reinforcements. The steel bending has to be done very precisely with small tolerances in millimeters.

Also placement and binding of the reinforcements bars in the moulds before casting has to be done with care and needs constant supervision.

The pre-cutting and bending of the reinforcements bars can be done on tables with fixed measurements and blocks and holes for bending which can reduce miscuts and improper bending to a minimum.

During the casting process, when the mould is on the vibration table and the concrete is filled in, the reinforcement bars have to be kept in the right position during vibration. This was the most critical moment in the whole operation and needed a very capable and careful worker in charge.

Before each element was erected, it was inspected for faults.

It sometimes happened (approx. 1 out of 100) that the bars were visible in some places at the surface of the element and, therefore, the element had to be destroyed.

Conclusions: With future experiments a tolerance of at least 20 mm between the reinforcement bars and the sides of the mould is recommended.

MAIN WALL ELEMENT

USED AT UHURU PHASE IV.
AND JUJA ROAD DEVELOPMENT
SCHEME PHASE I.

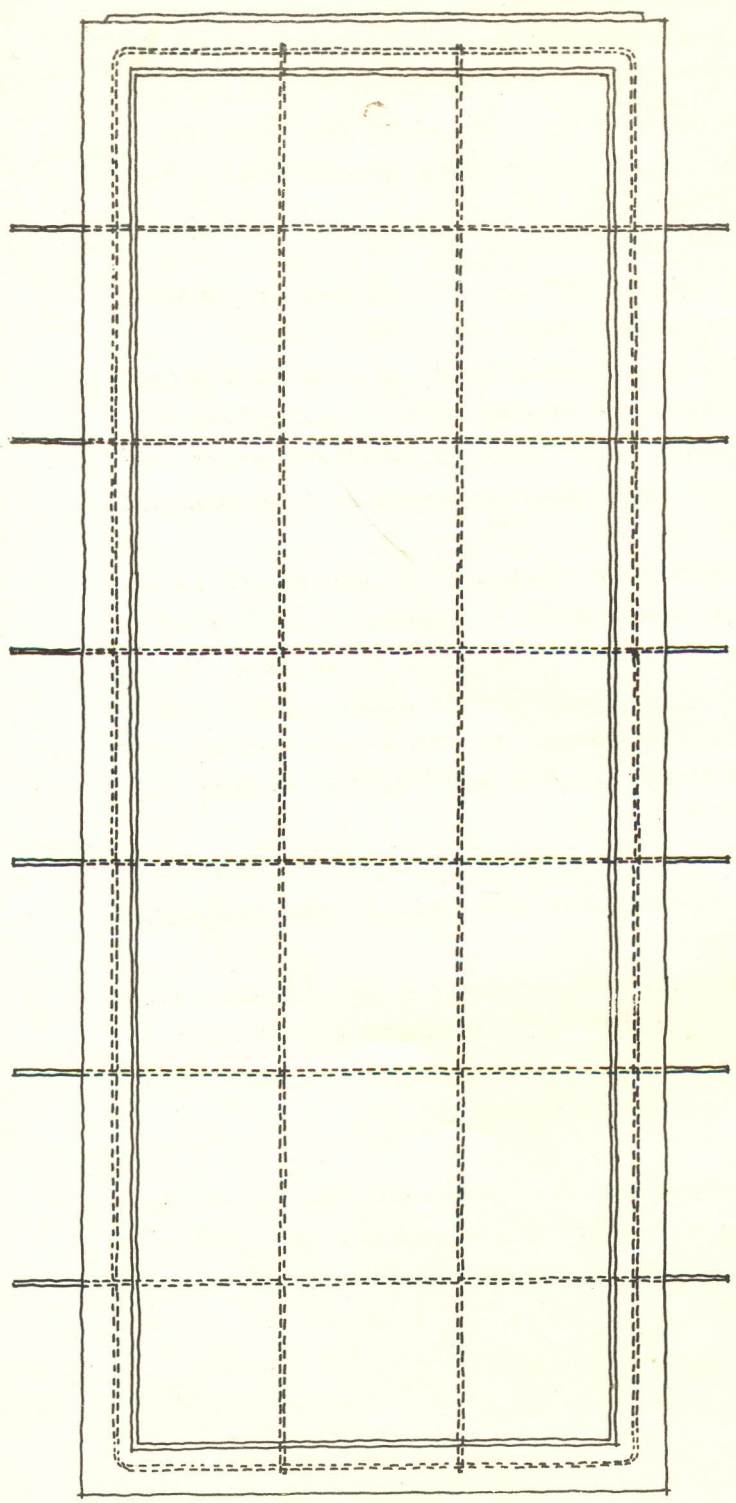

← 90 →
FRONT

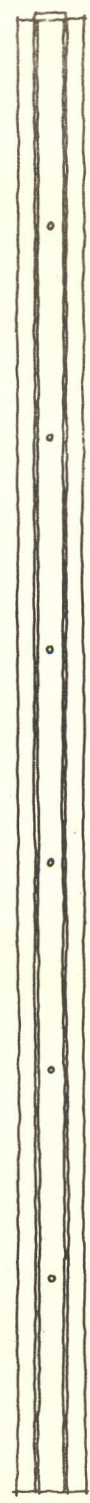

← 10 →
SIDE PROFILE

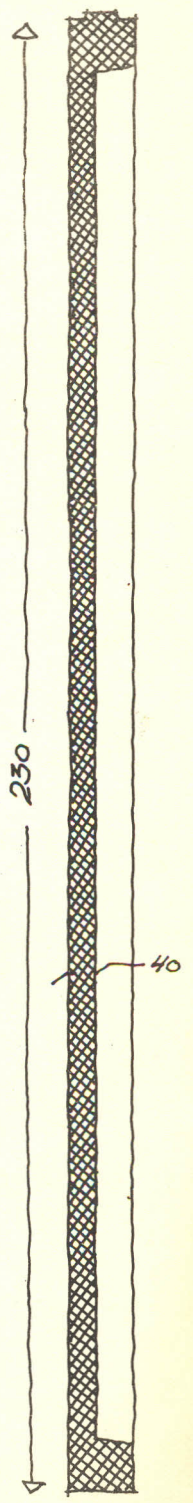

230
40
SECTION

CONCRETE MIXING AND CASTING OF ELEMENTS

For mixing of the concrete a horizontal based pan mixer was used, approximately 1.4 m in diameter.

The concrete mix used for all types of elements was 1:3:4, (one cement, three sand and four aggregate). The cement was ordinary Portland cement produced in Kenya.

The sand came from river beds, and the quality was relatively good, although stones and dirt had occasionally to be removed.

The aggregate was crushed granite $\frac{1}{2}$ " and $\frac{3}{8}$ " mixture of a very good quality.

For measuring of sand and aggregate for mixing small metal boxes were used.

These boxes were easy to handle but proved a problem to count the right number to be used for each mix.

A slump test was used to control the Water-cement ratio.

The wet concrete was taken from the pan mixer in a wheelbarrow to the prepared mould lying on one of the vibration tables and shovelled into the mould. The mould was vibrated for 1-1 $\frac{1}{2}$ minutes, and the concrete surface was levelled with a piece of timber.

The mould frame was then cleaned of surplus concrete, lifted to the trolley, and moved to its hardening place.

The still wet surface of the element was powdered with cement and smoothed with a steel plate tool.

Conclusions: The quality of the concrete mix has to be controlled very strictly and measuring of sand and aggregate has to be done very simply and effectively.

VENTILATION ELEMENT.

USED AT UHURU PHASE IV.

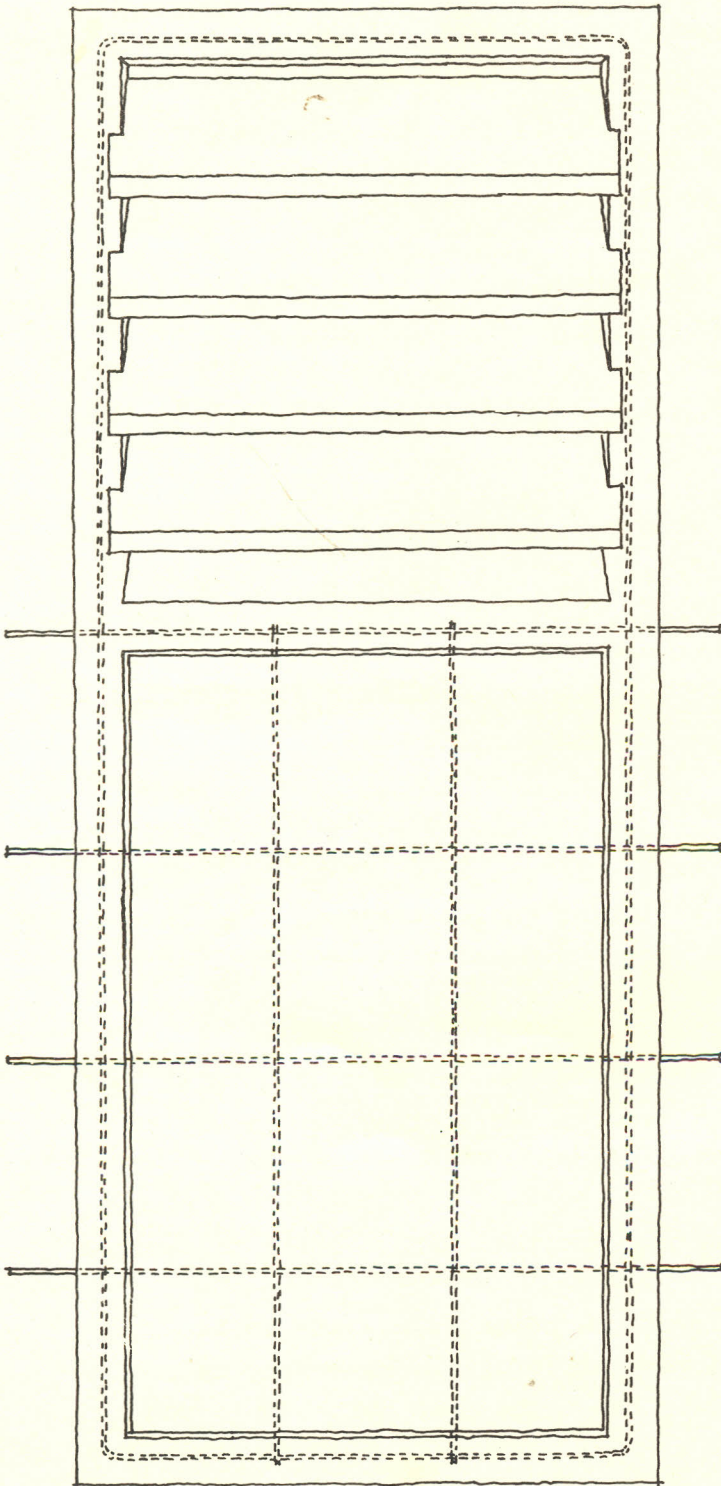

← 90 →
FRONT

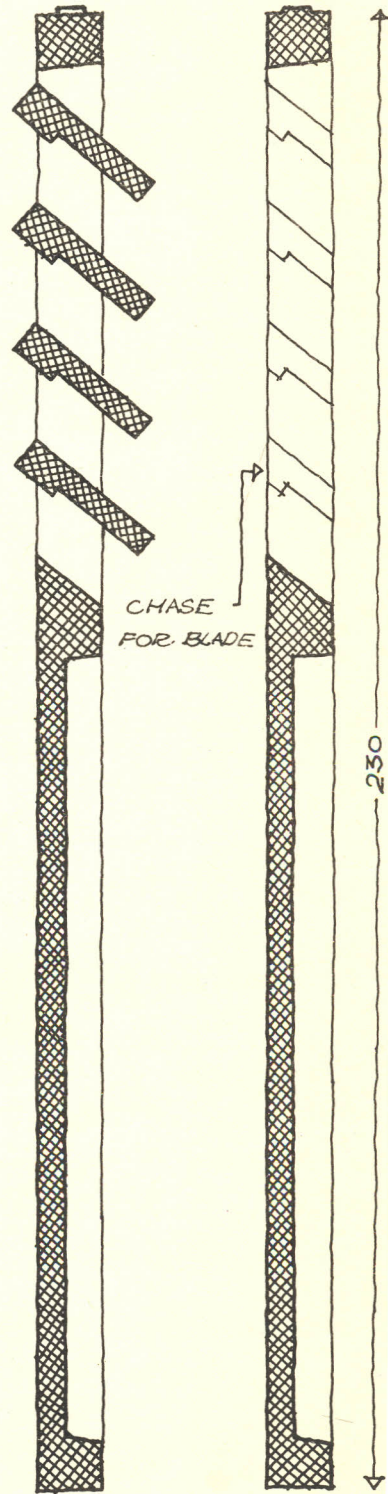

SECTIONS
THROUGH LOUVRE BLADES

HARDENING AND STACKING OF ELEMENTS

When the moulds were filled and the surface of the element was smoothed, they were left to harden for $2\frac{1}{2}$ -3 days. Then the element was removed from the mould and transported to the stacking area by the trolley.

The stacking area was outside the roofed area but should, if the budget had allowed for it, have been shaded to avoid the elements to dry out too quickly and to avoid the possibilities of cracks.

After seven days, the concrete had reached $\frac{3}{4}$ of its final strength and particularly during this period, it was very important to keep the elements moist.

The elements were sprayed with water during day time.

After 9-12 days, the elements were transported from the stacking area to the building site for erection.

Conclusions: The stacking area should be shaded and fitted with a sufficient number of water taps.

A simple sprinkler, such as used for watering lawns, can be effective to keep the elements wet.

The elements at the stacking area should be grouped and marked after each day's production, recording number of elements and date of casting.

TRANSPORT OF ELEMENTS.

A TRACTOR AND A TRAILER WERE USED FOR TRANSPORT OF ELEMENTS FROM STACKING AREA TO BUILDING SITE. LOADING AND OFFLOADING WAS DONE BY HAND.

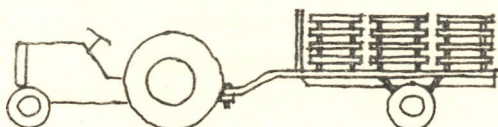

TROLLEY FOR INTERNAL USE AT THE P.C. YARD.

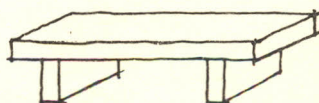
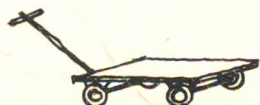

TIMBER SUPPORTS USED BETWEEN ELEMENTS WHEN BEING TRANSPORTED.

STACKING AREA.

AFTER REMOVING FROM THE MOULDS, THE ELEMENTS WERE STACKED FOR AT LEAST ONE WEEK. THE ELEMENTS WERE SPRAYED WITH WATER EVERY DAY.

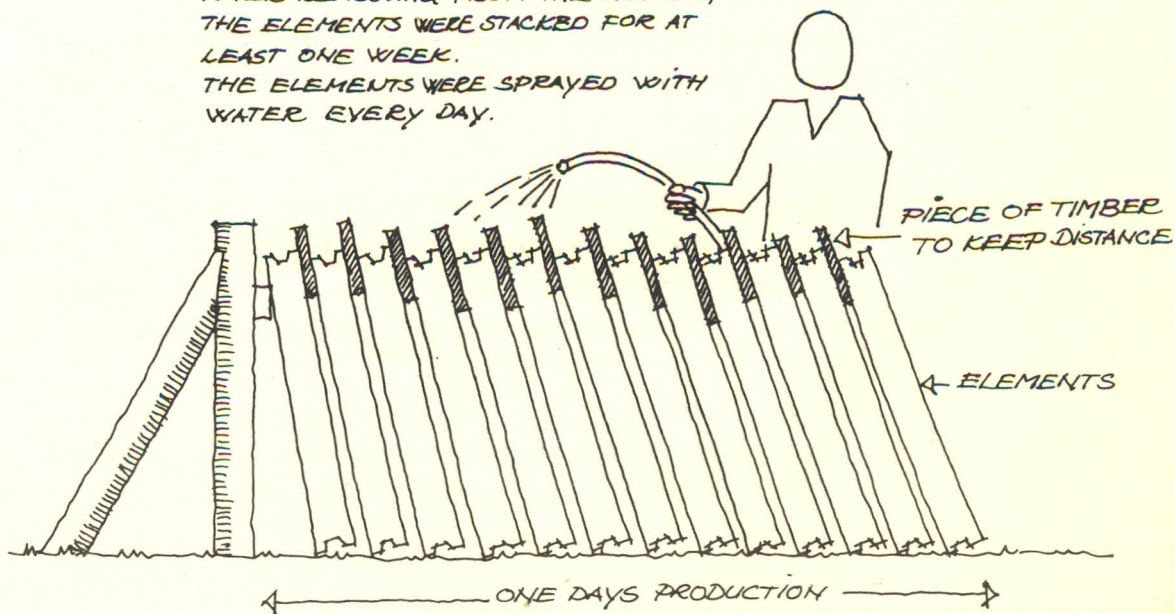

TRANSPORT OF ELEMENTS ON SITE

A tractor and a trailer were used to transport the elements from the stacking area to the building site. Loading and off-loading were done by manpower only.

Timber supports were placed between the elements to keep distances and to make it easier for the labourers to handle the big elements.

Transporting elements proved to be the most difficult task. There were a lot of cracks when the elements were loaded, transported and off-loaded.

If the tractor was driven too fast and the trailer bumped into a hole, the elements easily cracked.

Conclusions: The elements should be kept in a vertical position during transport.
A crane should be used for loading and off-loading.
The roads to the building site must be in good condition.
At the building site, the elements should be stacked either at the floor slab or at a place properly prepared.
To build with pre-fabricated elements requires a building site with proper access to each foundation for the transporting vehicles.

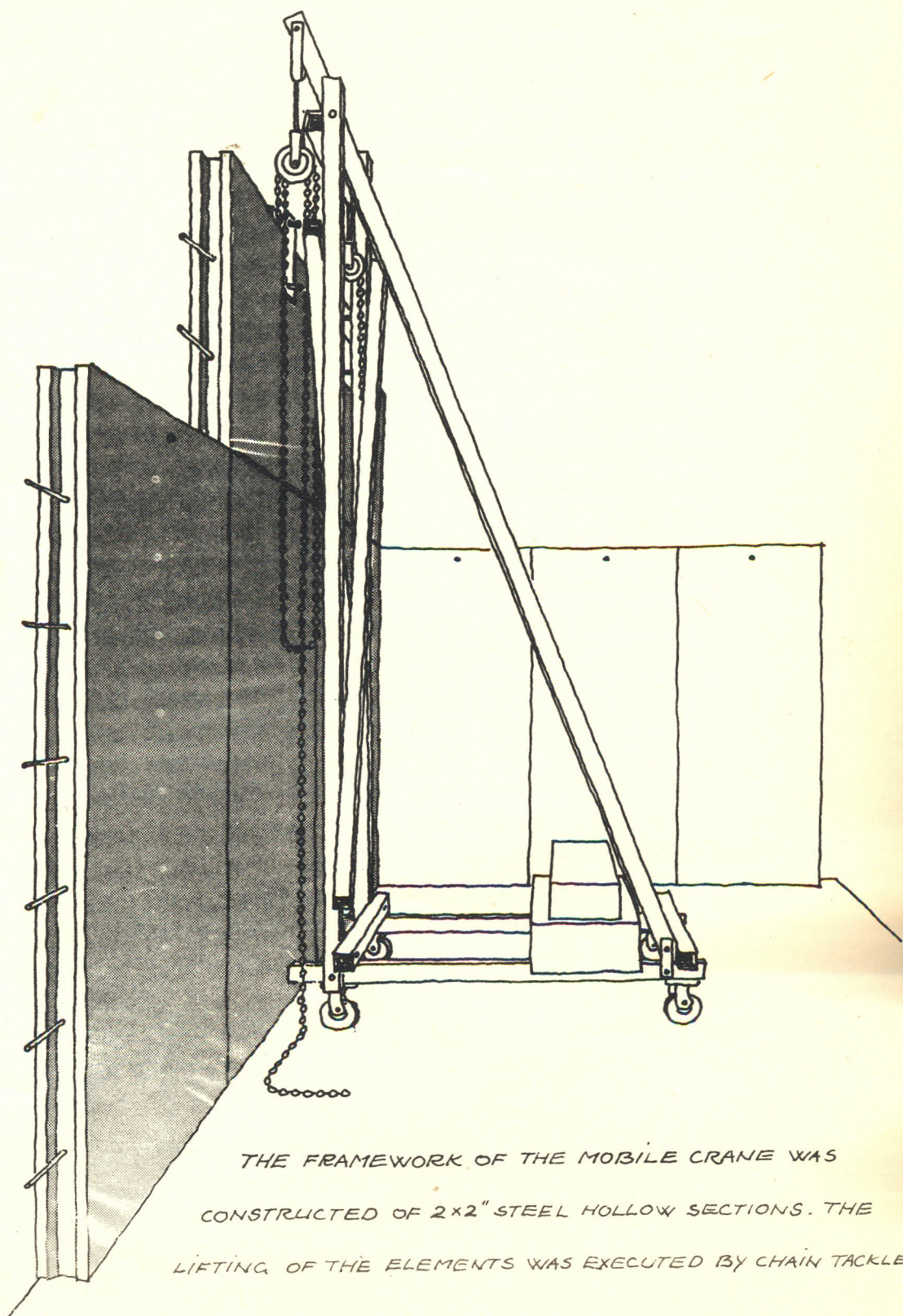
THE MOBILE CRANE

THE FRAMEWORK OF THE MOBILE CRANE WAS
CONSTRUCTED OF 2x2" STEEL HOLLOW SECTIONS. THE
LIFTING OF THE ELEMENTS WAS EXECUTED BY CHAIN TACKLES.

ERECTION OF THE ELEMENTS

The panels were erected on the foundations when these were completed with the floor slab and adjusted to level with a tolerance of ± 5 mm. The corner elements were erected first and kept in plum by adjustable supports. Then the various other elements were erected and supported. At the corners and T-joints, the reinforcement bars were bent and locked around a 12 mm bar before shuttering was placed. (see illustration page: 45)

Corners and T-joints were filled with concrete and the ordinary joints between the elements with cement mortar. For lifting the elements on top of each other a simple mobile crane, which operated with the help of two manpowered chain tackles, was used.

The erection gang was composed of 9 labourers to handle the elements, 2 mason to fill the joints, 2 mason assistants to provide the mortar and a foreman to supervise the operation. This working gang of 14 people erected about 40-50 elements a day under normal working condition.

Conclusions: The erection process needs a well trained gang of labourers and a very good supervisor. Small things such as watering joints before filling with cement mortar, adjusting the elements to plum, etc. can be done by ordinary skilled masons but a good foreman is needed to see it done correctly every time.

VENTILATION ELEMENT

USED AT JUJA ROAD DEVELOPMENT

SCHEME PHASE I.

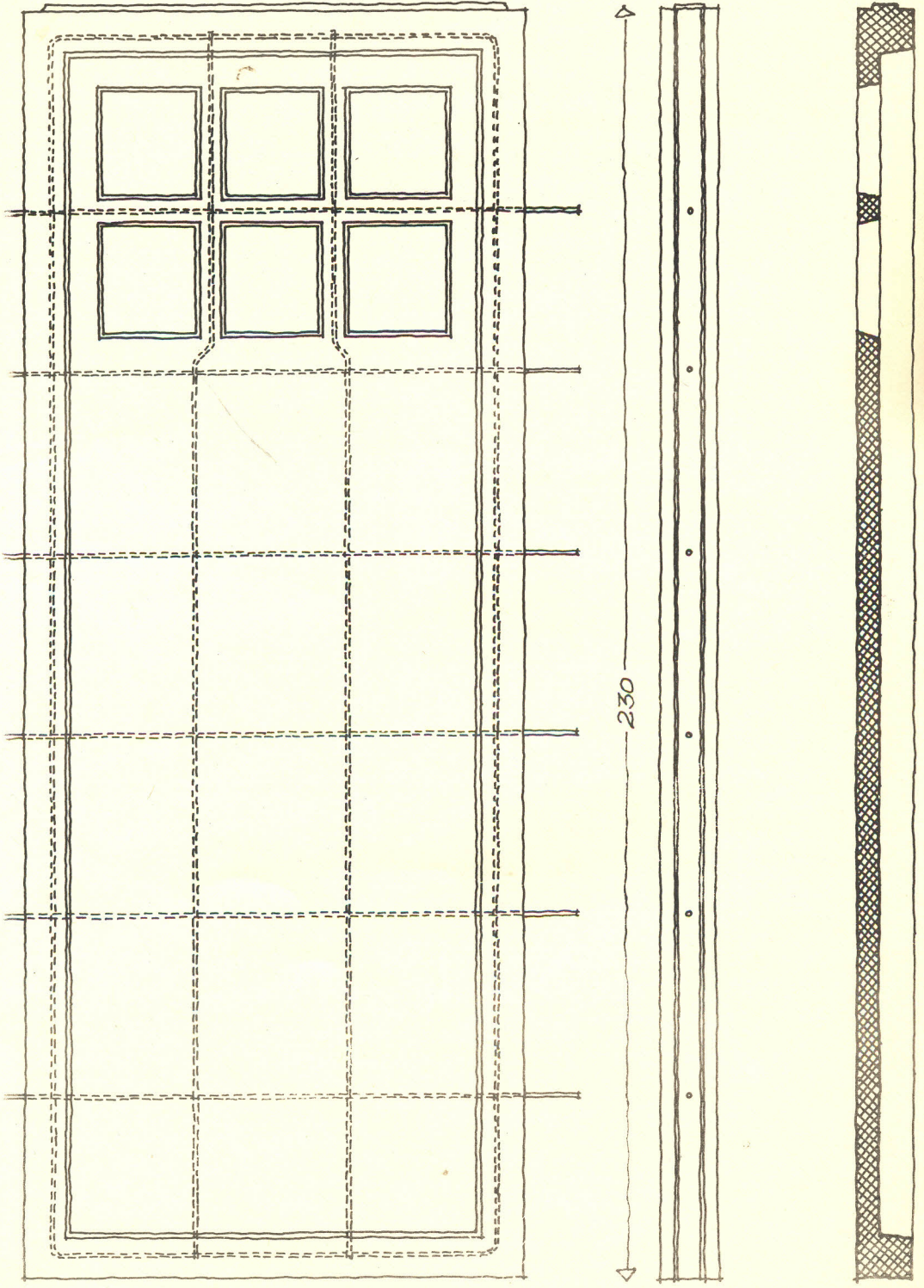

← 90 →

FRONT

230

← 10 →

PROFILE

SECTION

GABLE ELEMENTS, USED AT UHURU PHASE IV.

GABLE ELEMENT FOR ONE STORY HOUSE

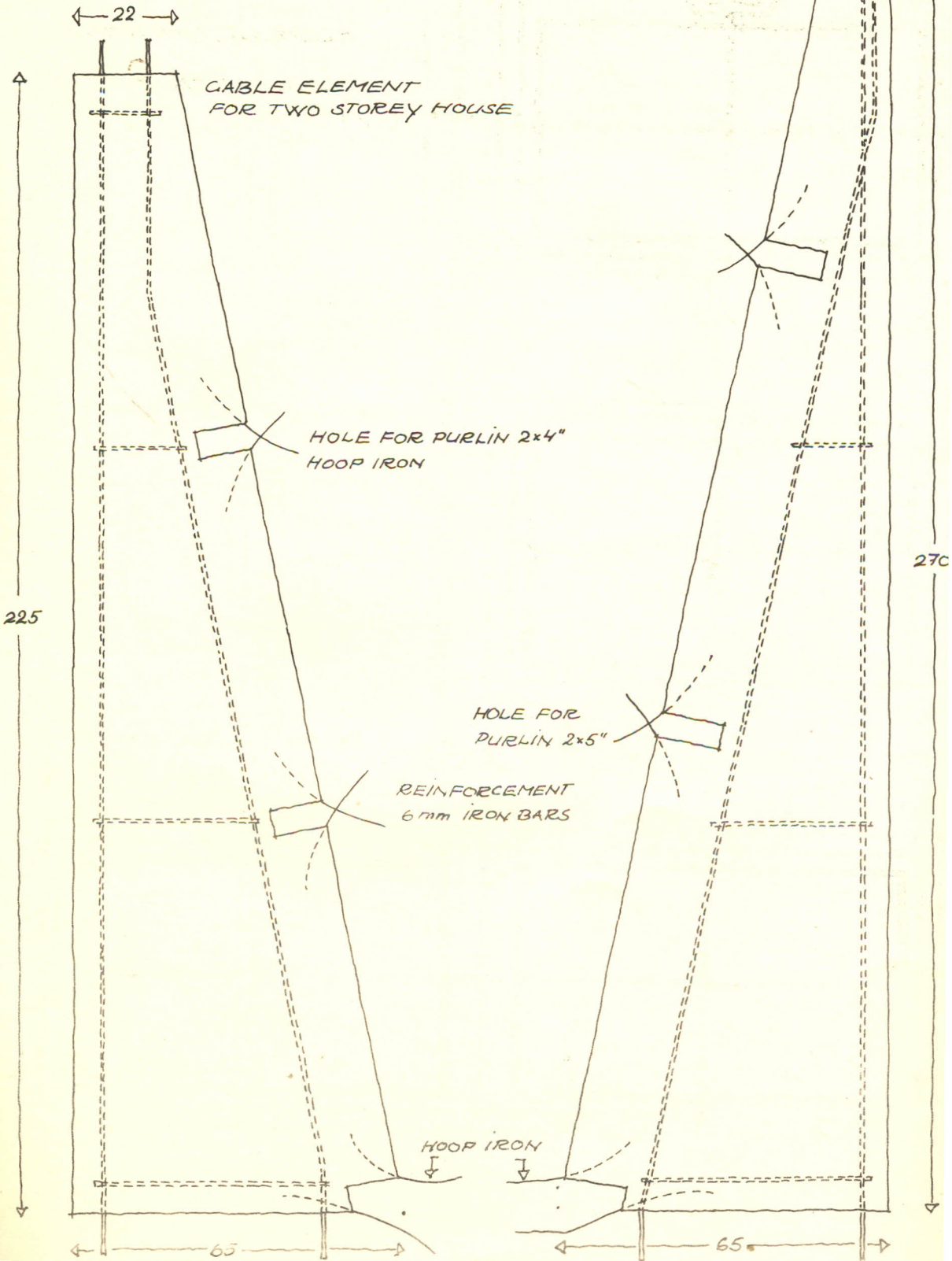

3
RIDGE ELEMENTS, USED AT UHLIRU PHASE IV.

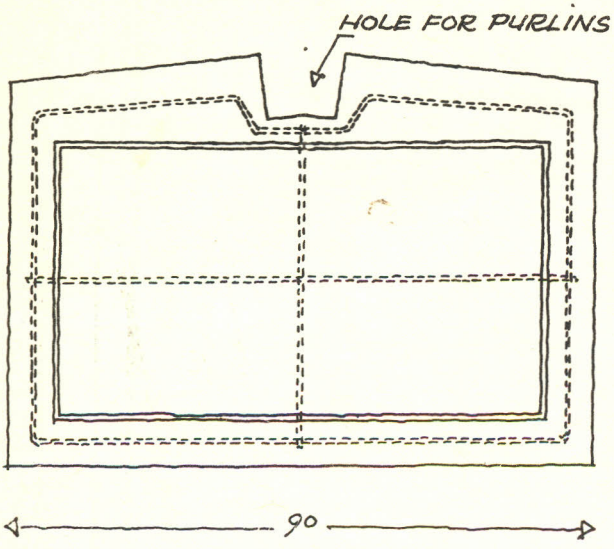

SPECIAL TOP-RIDGE
ELEMENT, TWO STORY
BUILDINGS ONLY.

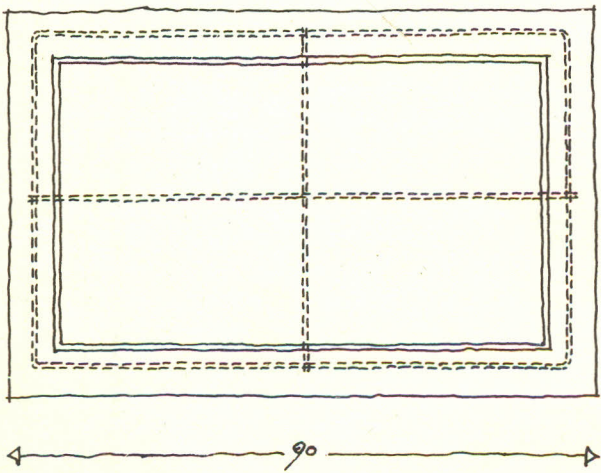

SINGLE RIDGE ELEMENT

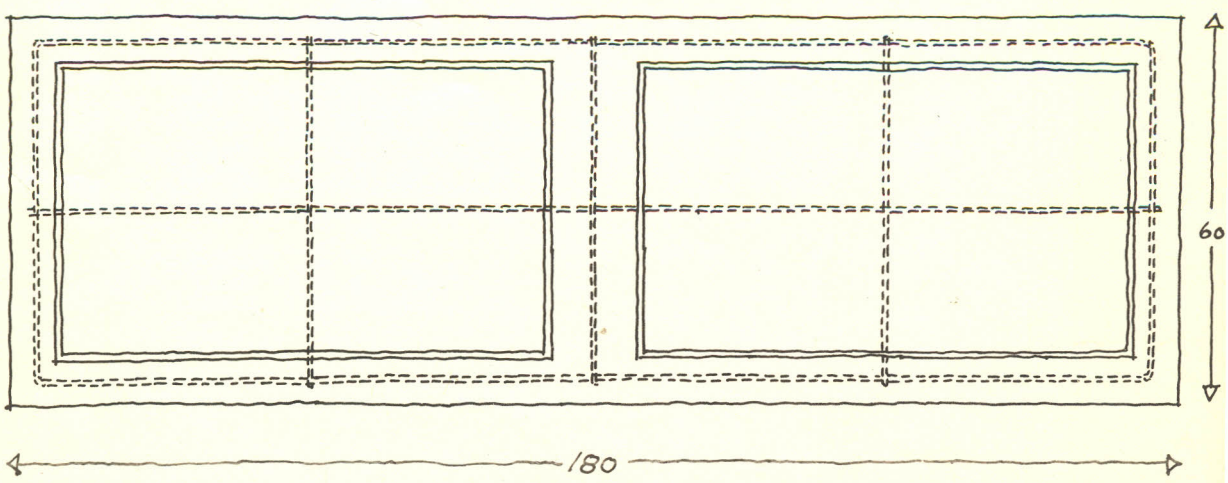

DOUBLE RIDGE ELEMENT

FLOOR ELEMENT

USED AT UHURU PHASE IV.

TWO STOREY BUILDINGS ONLY.

WEIGHT: 223 KG

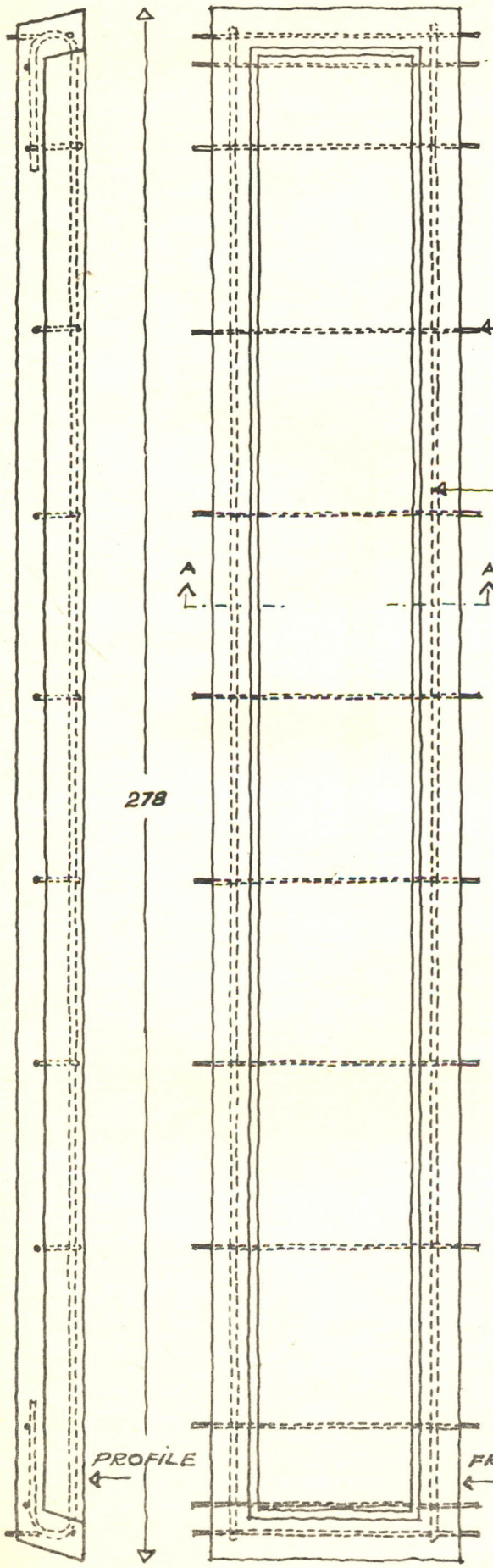

SECTION A-A

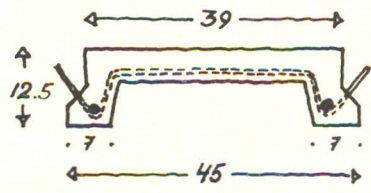

CONSTRUCTION DETAIL

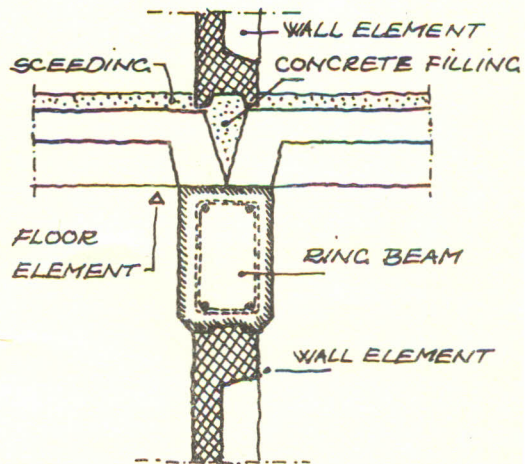

CONSTRUCTION DETAIL

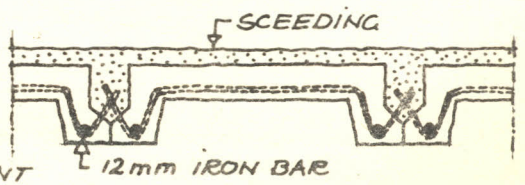

PROFILE

FRONT

TOP RIDGE ELEMENT.

DIMENSIONS: 95x180 cm

DETAIL OF TOP RIDGE CONSTRUCTION.

SECTION.

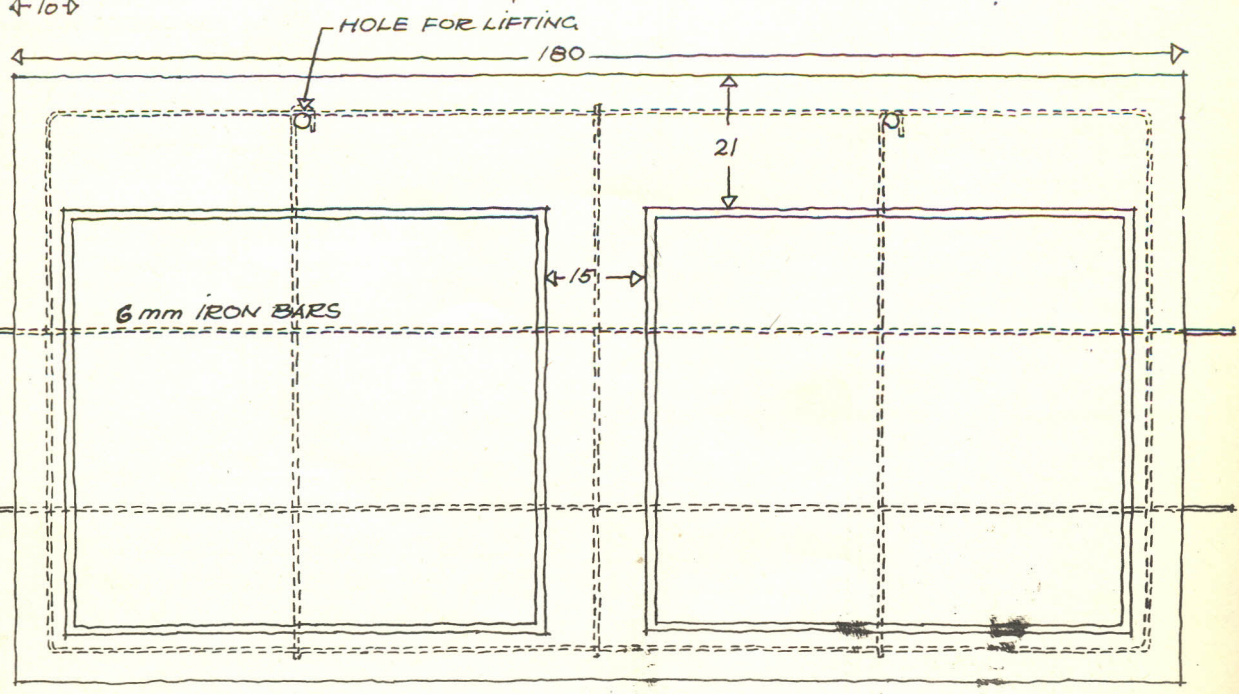
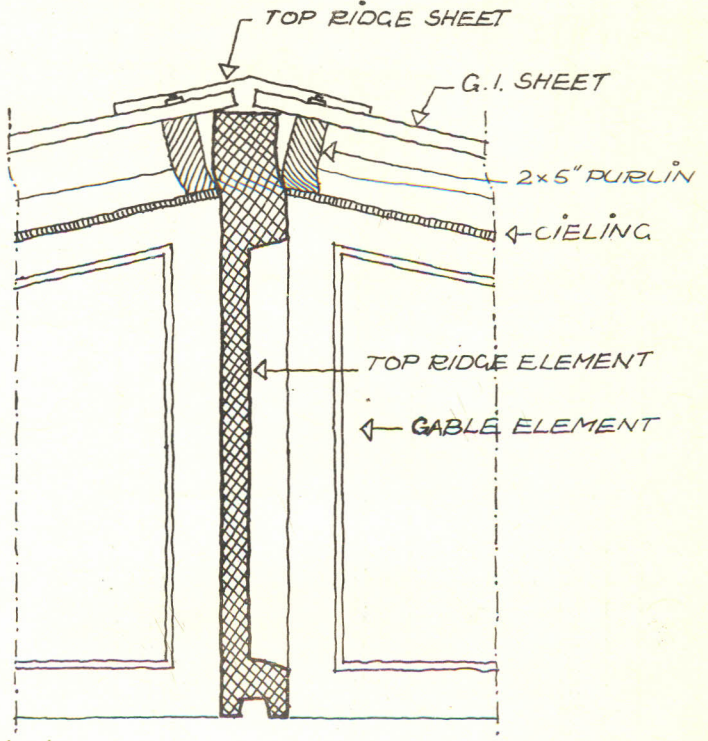
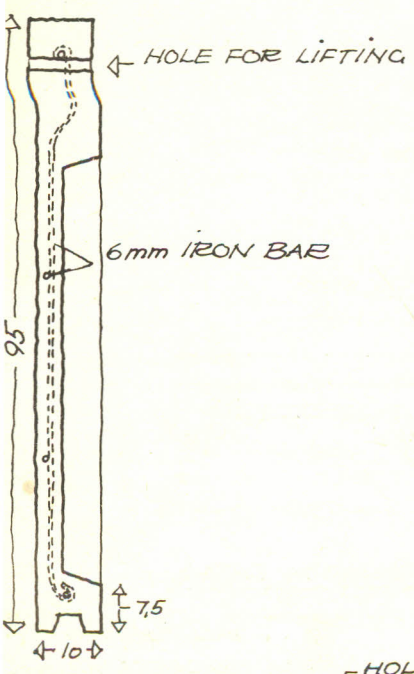

ELEVATION.

GABLE ELEMENT.

USED AT JUJA ROAD DEVELOPMENT

SCHEME PHASE I.

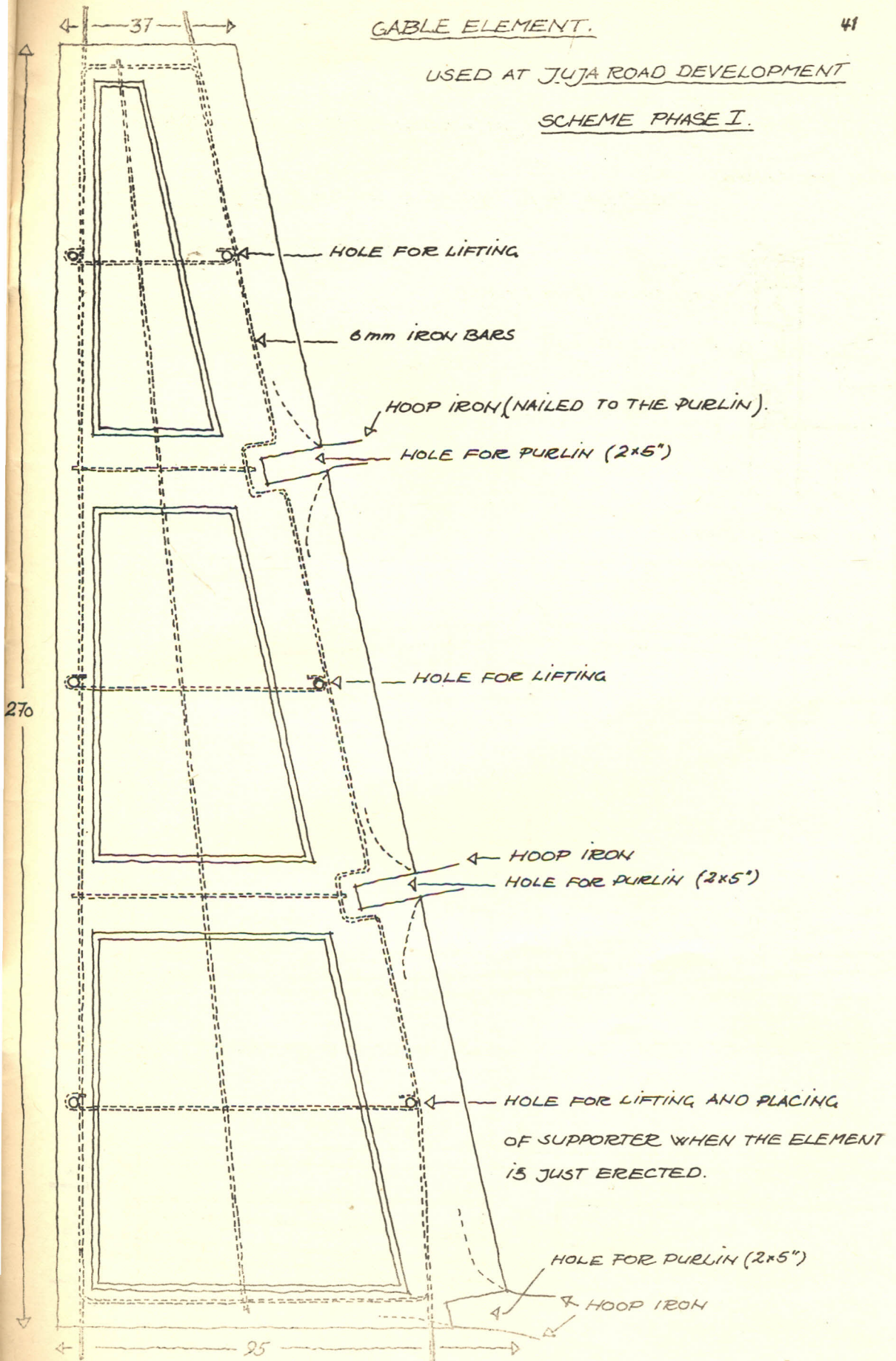

RIDGE ELEMENTS.

USED AT

JUJA ROAD DEVELOPMENT SCHEME

SECTION (A-A) THROUGH RIDGE ELEMENT WITH

ROOF CONNECTION

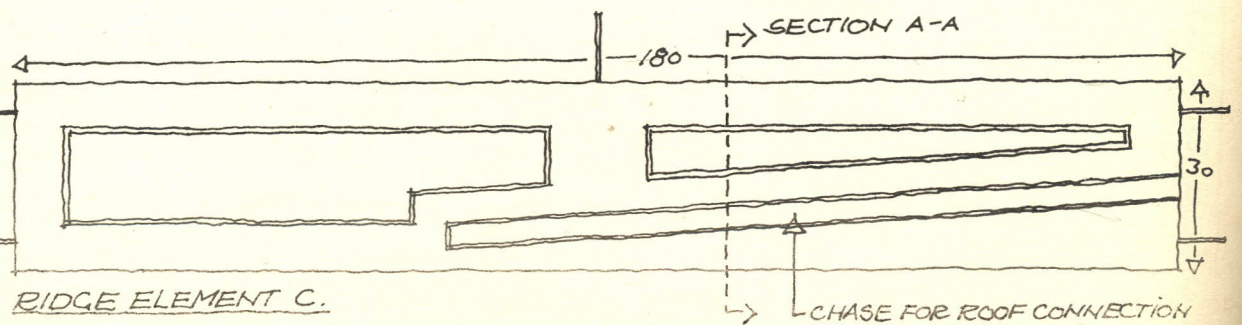
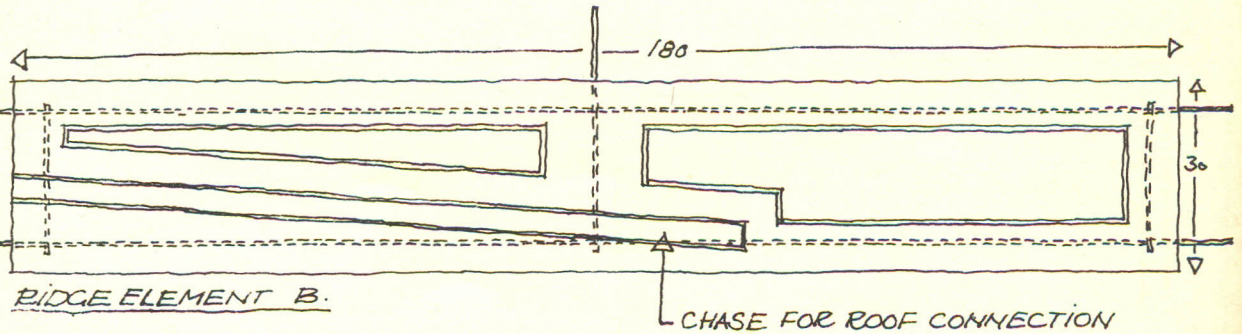
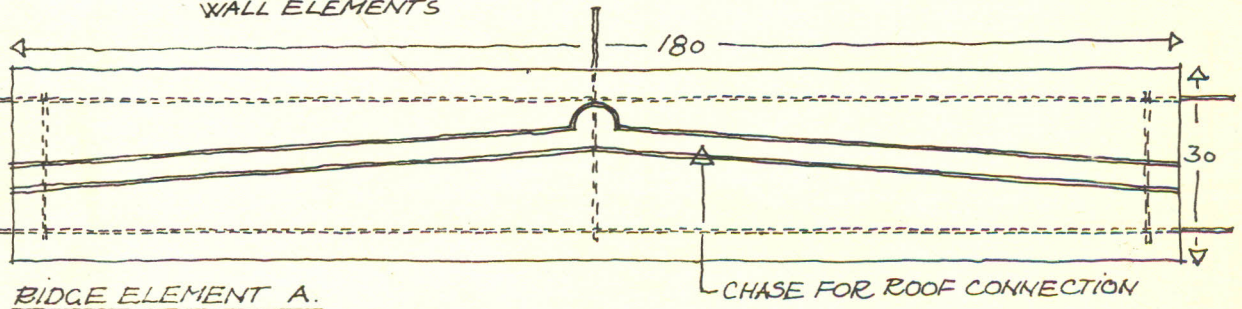
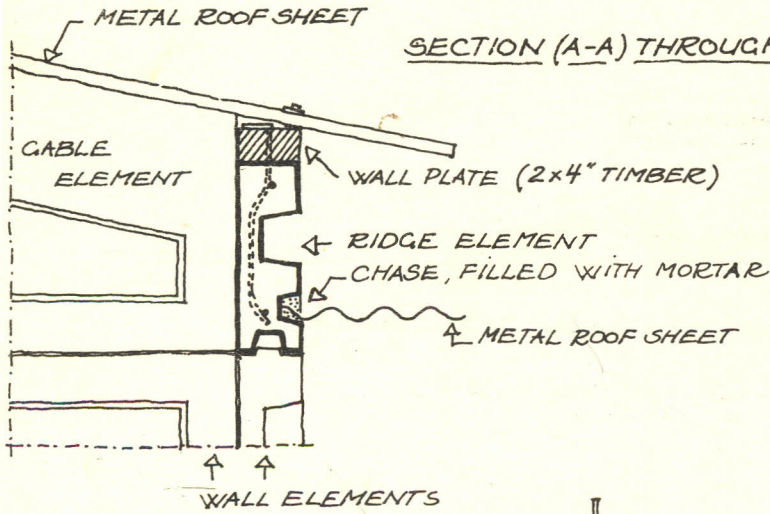

DETAIL OF CONSTRUCTION METODS , TWO STOREY BUILDINGS

UHURU PHASE IV.

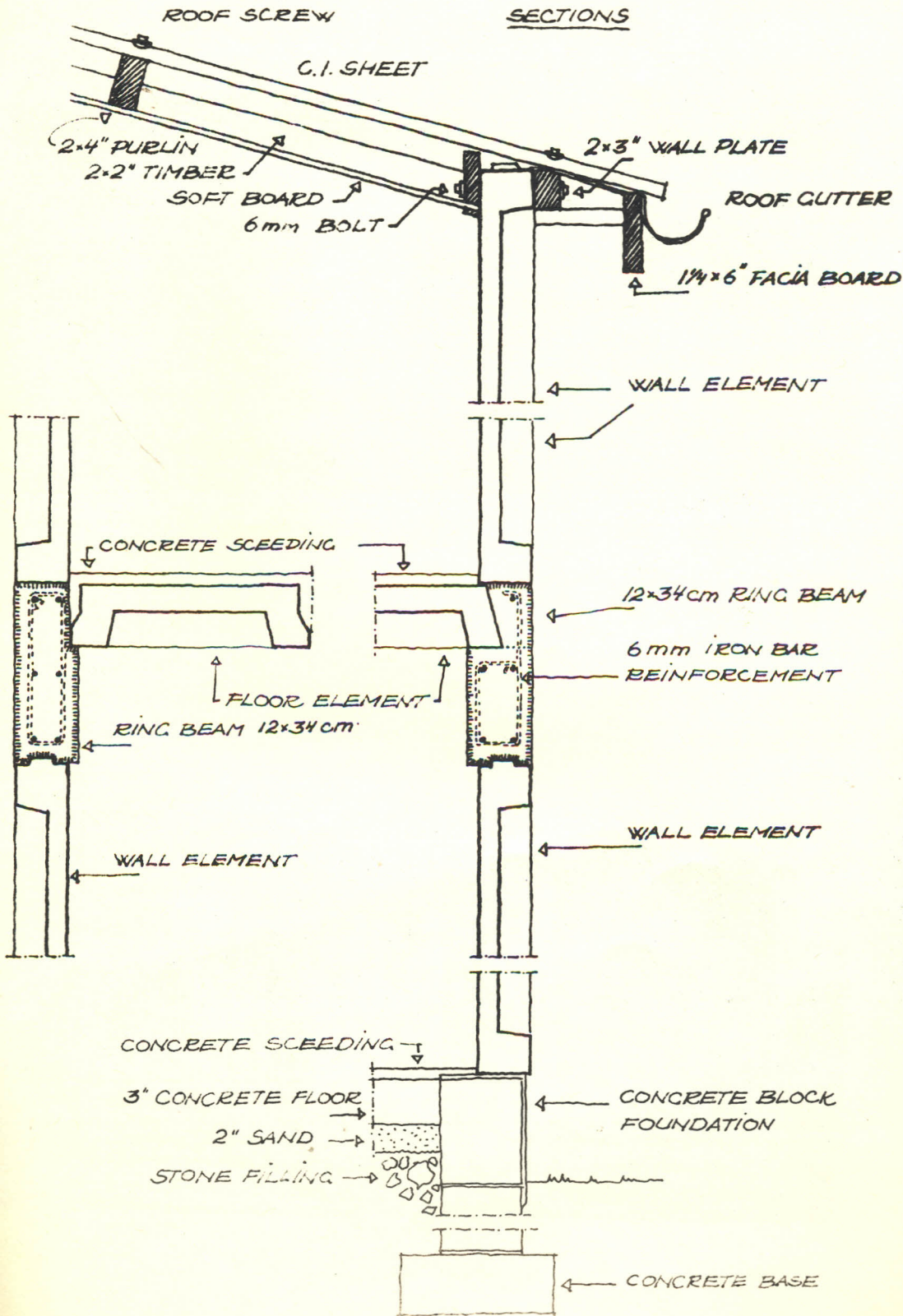



ONE STOREY HOUSES, JUJA ROAD DEVELOPMENT SCHEME PHASE I
SOURCE: THE AUTHOR

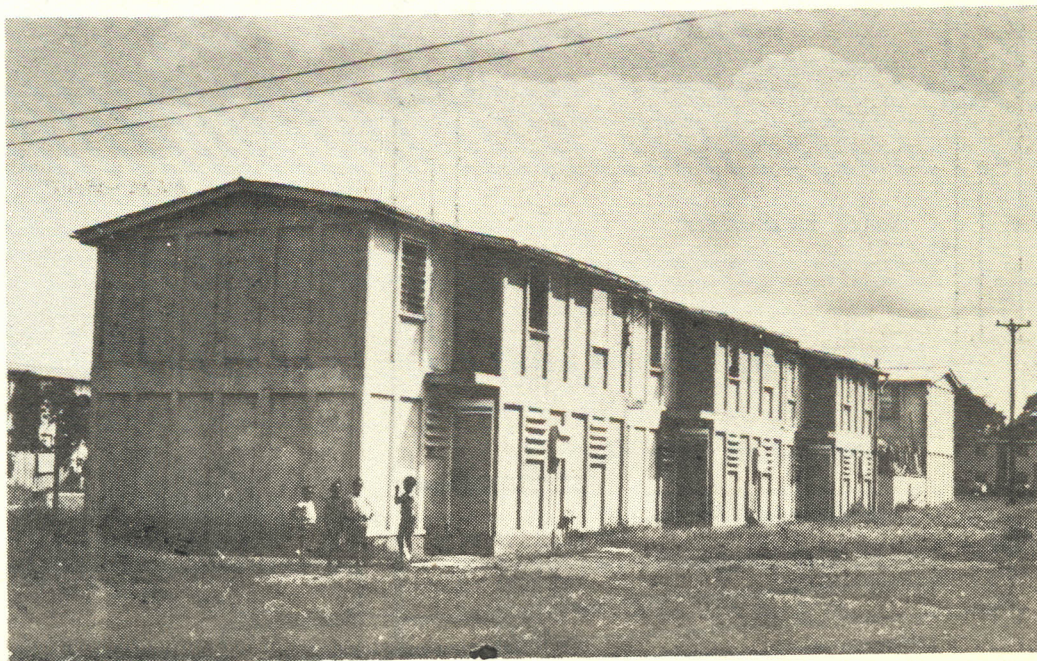

TWO STOREY HOUSES, UHURU PHASE IV
SOURCE: THE AUTHOR

CONSTRUCTION DETAILS.

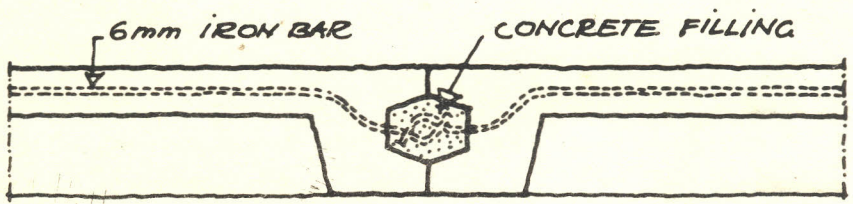
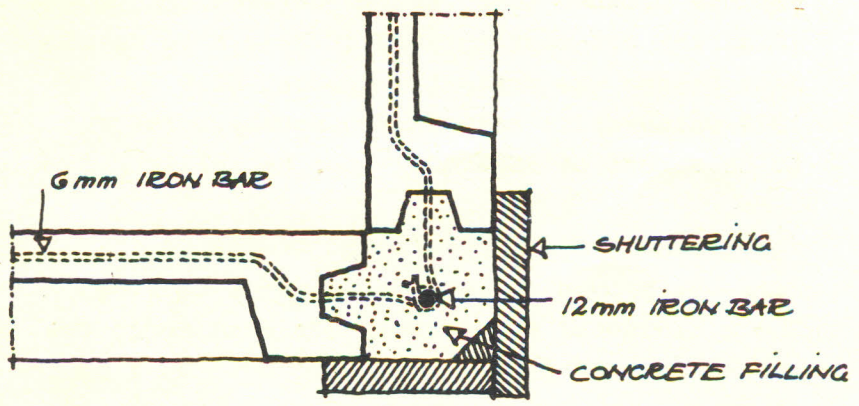
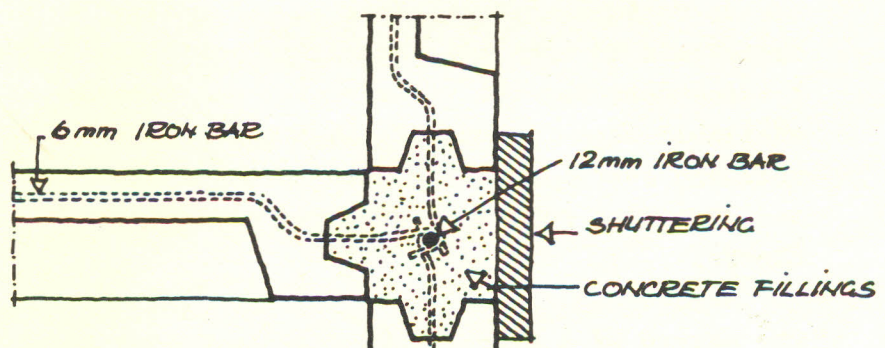
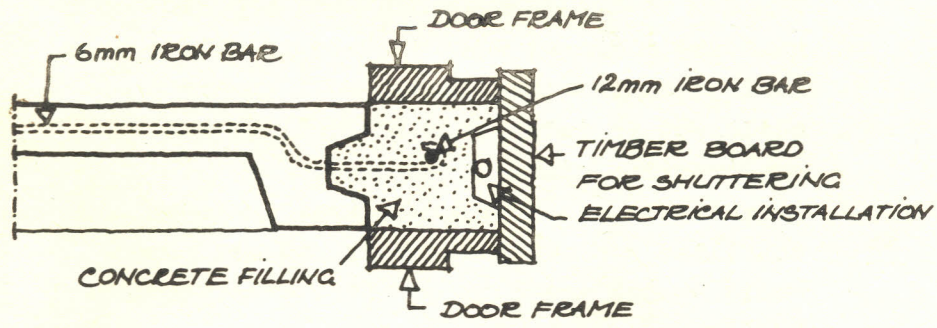

CONCLUSIONS

The aim of the experiments with precast concrete building elements was to learn if this system could compete with conventional concrete block buildings in terms of cost, quality and construction time.

At the same time, it was a test to learn how unskilled and skilled labour and craftsmen would handle the task of house construction based on a new building technique.

Due to various circumstances it has proved impossible to make a breakdown of buildings and service cost for the two schemes, but figures available seem to indicate that the precast building system could compete in terms of time and cost with houses constructed of concrete blocks.

The set-up of a pre-casting yard is costly and takes time. The number of houses to be built has to be high if the cost of the pre-casting yard is planned to be shared between the houses. (E.g. the pre-casting yard at Juja Road Development Scheme was estimated to cost K£10,000 in 1972 which split between 400 houses works out to be a cost of KShs.500/- per house).

The training of labourers and craftsmen took time but proved to be without major difficulties. The training of supervisors was even more time consuming, and it was very difficult to find the right men to oversee the various tasks in the process of casting and erection of the elements. The success of the building system relied heavily on small things being done. Small things which required a very good knowledge of building techniques and, therefore, which are often neglected.

Two examples are given:

1. Watering of joints between elements before filling with mortar. To prevent the mortar from drying out too quickly, two buckets of water should be poured into the joints before filling, but this was often neglected and the results were weak joints which cracked later on.
2. Watering of elements undergoing the hardening process. One labourer was designated to do only this job, but even if the job was handed over to a new man every week, he became bored and showed no interest in what he was doing, watering the same ten elements the whole day.

The user reaction survey carried out at Uhuru Phase IV gave information about the present condition of the houses and the occupants described problems regarding maintenance and daily life in the houses.

The survey showed that 25-41% of the houses have small cracks in the joints between elements but none of the cracks proved to be of any risk to the overall strength of the structure. Houses sited close to the road, which is carrying heavy traffic, have problems of cracks. The occupants of the same houses complained of noise problems through the relatively thin walls. The houses are generally well liked by the owners and the occupants. Maintenance problems are mainly painting and filling of small cracks.

USER REACTION AND BUILDING PERFORMANCE SURVEY
UHURU PHASE IV

The aim of the survey was to examine the performance of the building system eight years after erection as well as to obtain information about the occupants' general attitude towards the building system regarding maintenance and problems related to the daily use of the houses. The survey is based on questionnaires covering 30% of the houses.

| <u>Questions:</u> | <u>Yes</u> | <u>No</u> |
|---|------------|-----------|
| 1. Is the owner of the house a resident: | | |
| a. Single storey houses | 63% | - 37% |
| b. Double storey houses | 50% | - 50% |
| 2. Number of households per house, | | |
| a. Single storey houses only one household | 79% | more 21% |
| b. Double storey houses only one household | 76% | more 24% |
| 3. Any crack problems between elements, | | |
| a. Single storey houses | 41% | - 59% |
| b. Double storey houses | 25% | - 75% |
| 4. Do you like the building system, | | |
| a. Single storey houses | 67% | - 33% |
| b. Double storey houses | 98% | - 2% |
| 5. Do you like to live in a double storey building, | 75% | - 25% |

The average number of people (including children) per house, single and double storey, came to 6 persons. The estimated number of people living at Uhuru Phase IV is 1768 persons. Gross residential density per hectare is 33.2 houses, approx. 200 persons per hectare.

SUMMARY OF CONCLUSIONS

The following points are summary conclusions extracted from this case study report;

1. The set up of a pre-casting yard is time consuming and costly.
2. Design of buildings and elements require a well trained staff of architects and engineers.
3. A labour force has to be trained to deal with the various aspects of production and erection.
4. Supervisors and foreman have to be trained.
5. Machinery, such as vibration tables, concrete mixer, cranes and transporting vehicles are necessary equipment.
6. Steel moulds are recommended even if they are expensive! they will pay off in the long run.
7. A mobile crane for loading and off-loading elements from the transporting vehicles is recommended.
8. Only building sites with proper access for transport, construction with precast elements can take place.

The above mentioned aspects have to be taken into consideration when plans are undertaken to set up a pre-casting concrete element yard. However, the constantly increasing demand for increasing the speed of house construction will favour a building industry based on rational production of houses of high quality and despite the heavily investment involved, a well planned pre-casting yard will, without doubt, prove to be a good investment.