

University of Nairobi
School of the Arts and Design
Masters of Arts in Design – July 2015

Proposing Criteria for Quality Production of Handicrafts
in Kenya;
A case study of Leather and Sisal bags

A Project report submitted in partial fulfillment of the requirements for
the Degree of Masters of Arts in Design.

Student's Name: Kamuiru J.C.W
Registration No: B51/69827/2011

DECLARATION

I certify that the work presented in this thesis is, to the best of my knowledge and belief, original except as acknowledged in the thesis. I hereby declare that I have not submitted this material, either in whole or part, for a degree at this or any other institution.

Julia Christine Waruguru Kamuiru

The thesis has been submitted for examination with the approval of the following University Supervisors.

Dr. Lilac Osanjo
School of the Arts and Design
University of Nairobi

Mr. Muriithi Kinyua
Director
School of the Arts and Design
University of Nairobi

DEDICATION

This thesis is dedicated to my family;

My father George Njau Kamuiru, mother Margaret Janet Kariuki and sister Gladys Wamaitha for their love and encouragement in my studies.

ACKNOWLEDGEMENTS

I extend sincere thanks to the following individuals and institutions for their assistance and contribution towards the completion of this research.

My most sincere gratitude to my supervisor, Dr. Lilac Osanjofor her tireless effort, guidance and professional advice that made this thesis what it is.

My appreciation goes to all lecturers at the School of the Arts and Design for their contributions in seminars held at different times when sections of this thesis were presented and discussed.

I wish to express my gratitude to the producers at Bombolulu, Sanabora, Bahati and Kariokor who agreed to take the time to respond to my questions giving me invaluable data that was used in this study.

My deepest appreciation is due to James Murimi, my intellectual friend who has been a great source of motivation and inspiration.

Acronyms

AGOA - African Growth and Opportunity Act

AHPADA - ASEAN Handicraft Promotion and Development Association

APDK - Association for the Physically Disabled of Kenya

ASEAN - Association of South East Asian Nations

CIGS - Cultural Industries Growth Strategy

CITEM - Center for International Trade Expositions and Missions

COFTA – Cooperation for Fair Trade in Africa

ECOWAS - *Economic Community of West African States*

EPC- Export Promotion Council

ITC- International Trade Center

MoE - Ministry of Education Kenya

PCHI - Philippine Chamber of Handicraft Industries

PDDCP - The Product Development and Design Center of the Philippines

PhilGED- Philippine-German Export Development Programme

TESDA - Technical Education and Skills Development Authority

TIVET - Technical, Industrial, Vocational and Entrepreneurship Training

TVET - Technical, Vocational, Education and Training

UNESCO - United Nation Educational Scientific and Cultural Organisation

WFTO – World Fair Trade Organisation

WIPO - World Intellectual Property Organization

KIPI - Kenya Industrial Property Institute

KIRDI - Kenya Industrial Research and Development Institute

Kshs - Kenya Shillings

ABSTRACT

Kenya's commercial handicrafts are produced by small and medium enterprises in the Juakali sector. Most of the producers in the Juakali sector are operating informally mainly using local resources, promoting local creativity and skills to produce handicrafts for the local, regional and global markets. In Kenya, the quality of the handicrafts created is diverse among the producers and consumers. Handicraft producers in Asia, example the Philippines are seen as respectable contributors of foreign exchange in their economies. The Philippines handicraft industry has the support of national institutions that are formed to assist the various producers. Through this guidance, Philippine handicrafts are identified and accepted globally among the high-end markets. The research looked at the Philippines handicraft situation as an ideal example where handicraft sales were thriving. In Kenya although the country has a thriving handicraft sector, the supporting institutions are not consolidated and clearly defined in their roles to the handicraft sector. This research focused on collecting information on the quality of handicrafts in Kenya. It looked at the set standards required for handicrafts to be more competitive in the global markets.

The researcher identified three handicraft producer groups as the sample for this research. This was a qualitative study and data was collected through participant and non-participant observation, structured and semi structured interviews and focus group discussions. Data analysis and presentation was descriptive. From the data collected, the production of quality handicrafts in Kenya was seen to be varied among the producers. A nationally recognised criterion that identifies the quality of the handicrafts was lacking. An ideal production process with the key criteria checklist is proposed to guide in the production of quality handicraft products. With better quality handicraft products, producers would increase their earnings and there would be economic growth countrywide.

KEY WORDS:artisans, design process, handicrafts, product attributes, production process, quality, standards.

Contents

CHAPTER 1: INTRODUCTION	6
1.1 Background of the problem	6
1.2 Problem statement.....	9
1.3 Purpose/Goal.....	9
1.4 Objectives	9
1.5 Research Questions.....	10
1.6 Justification and significance of the study	10
1.7 Limitations and assumptions.....	10
1.8 Assumptions.....	11
1.9 Scope.....	11
1.10 Definition of Terms.....	13
CHAPTER 2: LITERATURE REVIEW	14
2.1 Overview.....	14
2.2 Design research and handicrafts	15
2.3 Design processes in craft production	18
2.3.1 Economic gain for design driven handicrafts	21
2.3.2 Cultural heritage in handicrafts.....	22
2.4 Skills transfer and apprenticeship	24
2.5 Raw materials for handicrafts	25
2.5.1 Leather production and handicrafts	27
2.5.2 Sisal fiber and the Kiondo.....	28
2.6 Policies and benchmarks on handicraft quality	30
2.6.1 Professional intervention for craft producers.....	35
2.6.2 Education and training	40
2.7 Summary	42
CHAPTER 3: RESEARCH METHODOLOGY	45
3.1 Overview.....	45
3.2 Research Design.....	45
3.3 Population	46
3.4 Sampling	47

3.4.1 The sample	48
3.5 Research Tools and Instruments	49
3.5.1 Records and reports from the producers	49
3.5.2 Participant Observation.....	50
3.5.3 Naturalistic Observation	51
3.5.4 Interviews.....	52
3.5.5 Focus group discussions	54
CHAPTER 4 FINDINGS AND ANALYSIS	56
4.1 Overview.....	56
4.2 Product attributes of leather and sisal bags.....	56
4.2.1 Bag shapes	56
4.2.2 Bag sizes	62
4.2.3 Decorations, patterns and finishes	65
4.2.4 Bag ranges and function.....	69
4.3 Materials and Tools.....	75
4.3.1 Materials	75
4.3.2 Material Sources	78
4.3.3 Tools and Machinery	84
4.4 Product Realisation Processes.....	91
4.4.1 Product design and development	91
4.4.2 Ideation	93
4.4.3 Sampling	98
4.4.4 Production process.....	102
4.4.4.1 Skills training	106
4.5 Summary of Findings.....	111
Chapter 5 Discussions.....	113
5.1 Overview.....	113
5.2 The Ideal Production Process.....	114
Chapter 6: RECOMMENDATIONS	121
References:.....	122
Websites	125
Interviews.....	127
Appendix A.....	128
Appendix B	130

Appendix C	132
Appendix D	132
Appendix E	133
Appendix F	134
Appendix G	135
Appendix H	136
Appendix I	137
Appendix J	138
Appendix K	138
Appendix L	139

Figure 1.1: Map of Kenya.....	12
Figure 2.1: Design process as proposed by Douglas (2001).....	18
Figure 2.2: The simplified dynamic design process defined by Roy (N.D)	19
Figure 2.3: Product design process by Artisanwork.	20
Figure 2.4: Hand-woven Palmyrah leaf Chettinad 'Kottan'	32
Figure 2.5: Bridal Jewelry box from Bangladesh.....	32
Figure 2.6: Countries in the AWARD programme in Asia.	34
Figure 2.7: Conceptual framework	44
Figure 4.1: Simple sketches showing shapes of Bombolulu's travelling bags.....	57
Figure 4.2: Simplified sketches showing shapes of ladies bags from Bombolulu.....	58
Figure 4.3: Simplified sketches of large handbag from Sanabora.	59
Figure 4.4: Large handbag from Sanabora showing shaping options.....	60
Figure 4.5: Simple sketch of Makena medium size bag from Sanabora.	60
Figure 4.6: Simple sketches of Makena small and extra small bags from Sanabora.....	61
Figure 4.7: Simplified sketches of kiondo shapes and sizes from Bahati weavers.....	61
Figure 4.8: Simplified sketches of medium size kiondo altered shape from Bahati weavers.	62
Figure 4.9: Leather handles and finish of kiondos at Kariokor market.	64
Figure 4.10: Different finish of handles on medium size kiondos from Bahati weavers.	65
Figure 4.11: Sanabora large handbag details of patterns and decorations.....	66
Figure 4.12: Decorations on kiondo as seen at Kariokor market.....	67
Figure 4.13: Leather binding finish with lining and zipper on a kiondo from Bahati weavers	68
Figure 4.14: Kiondos with various decorative band patterns at the Kariokor market.	69
Figure 4.15: Leather and canvas travelling bags from Bombolulu Workshops	70
Figure 4.16: The reshaping option as seen on Bombolulu travelling bags.....	70
Figure 4.17: Ladies leather handbag collection from Bombolulu.	71
Figure 4.18: Colored leather swatches collection from Bombolulu workshops.....	79
Figure 4.19: Natural sisal (wefts) and colored sisal (warps) string for sale at the local market...	82
Figure 4.20: Natural sisal (weft strand) sizes for sale at the local market.	83
Figure 4.21: Handheld leather tools observed at Bombolulu workshop.....	85
Figure 4.22: Leather stitching machines observed at Bombolulu Workshop.....	86
Figure 4.23: Artisans observed working at Sanabora design house.	87
Figure 4.24: Members of Bahati weavers observed working on kiondo finishing	88
Figure 4.25: Artisan observed fixing the lining in a kiondo at the Kariokor market.....	89
Figure 4.26: A simple design sketch of a bag from Bombolulu.	94
Figure 4.27: Detailed design sketch of a bag from Bombolulu.	95
Figure 4.28: A simple design sketch of a bag from Sanabora.	96
Figure 4.29: A detailed design sketch of a bag from Sanabora.	97
Figure 4.30: Template making as observed at Bombolulu.	98
Figure 4.31: Summary of the Production process at Bombolulu Workshop.	102
Figure 4.32: Summary of the Production process at Sanabora design house.	104
Figure 4.33: Summary of production process at Bahati Co-operative weavers.	106
Figure 5.1: Summary of the Production Processes of the 2 case studies.....	116
Figure 5.2: The Ideal Production Process for Kenya.....	117

Table 3.1: A summary of Population Distribution.....	46
Table 3.2: A summary of Sample Distribution.....	49
Table 3.3: Summary of Data Collection	55
Table 4.1: Summary of Product attributes.	74
Table 4.2: Summary of information on materials, sources and prices.....	84
Table 4.3: Summary of materials, tools and machinery used in the case studies.	91
Table 4.4: Summary of Production processes from the case studies.....	111

CHAPTER 1:INTRODUCTION

1.1 Background of the problem

The field of design and creative art are currently redefining their roles in society. Issues such as global climate change, depletion of natural resources, behavioral changes and different materials all have positive and negative design implications. Design is the basis of material culture and one of its goals is to promote a sustainable design process. Design also represents the role of creativity and technology. It recognises the importance and responsibility of research, while all the time being responsive, relevant and aware, in determining ethical, wise, conscious and sensitive solutions (Odundo *et al.*, 2008). This design knowledge is that which designers and non-designer (individuals, communities, institutions, and companies) can use in their processes of designing and co-designing (Manzini, 2008).

Kenyan handicrafts are a composition of exportable products of the crafts industry. They make a significant contribution to the national economy. According to Export Promotion Council (EPC, 2007), renowned crafts in Kenya include; baskets that are wicker and fiber works like the kiondo, leather products, wood and soapstone carvings, ceramics and jewelry. Renowned craftsmen include; Wamunyu woodcarvers, Akamba handicraft and Kisii soapstone carvers who have well established craft centers, Akamba weavers, and Maasai bead workers. Other handicraft establishments are Bombolulu Workshops, Malindi handicrafts, Undugu Fair Trade shop and Gallery Watatu, which sell an assortment of products both locally and abroad. The leading export markets for the Kenyan arts and crafts include Netherlands, Germany, Canada, U.S.A and France. Statistics in The Economic Survey of 2008 indicate that export earnings from commercial crafts were valued at Kshs. Sh449 million in 2001, rising to Sh550 million in 2006, and Sh760 Million in 2007 (epckkenya.org).

In a thesis research on the commercial craft sector in Kenya, Mwiti (2013) states that these figures are modest. They do not fully capture the revenue generated as a result of direct link of local sales of commercial crafts and the tourist sector. Currently exports of these products are declared

at point of exit as gift items of no commercial value. There is very little documented evidence on the contribution of commercial craft sector and hence the need to document its potential. Statistical data on the value and volume of exports on a product-by-product basis is not available. This is mainly because the codification system has not been implemented by Kenya's Central Bureau of Statistics or the Customs Department of the Kenya Revenue Authority (epckkenya.org).

According to the Kenya National AGOA Strategy (2012), Handicrafts are considered as Home and fashion accessories because they are a wide range of products that have high design and craftsmanship elements to them. In the USA, handicrafts are highly visual items that often get attention from consumers and policy-makers. The report states that the sector has not been doing well and is exhibiting signs of stagnation or decline in sales. Much of the Home and Fashion Accessories sector's ability to successfully sell into the US depends on the presence of agents that represent large, chain store buyers. These agents relay design requirements and quality-check each shipment, in effect acting as the home and fashion accessories market access inspection service.

The Philippines is the second largest world producer of handicrafts, mainly baskets out of indigenous materials. Over the years, Philippine handicrafts have evolved through innovative changes in designs. The artisans have indigenously overcome scarcity and increasing prices of raw materials by constantly producing new designs for their products. This industry continues to provide a respectable contribution to foreign exchange earning of the country (US\$71.9M in 2000). The sector provides livelihood to more than 1 million Filipinos and it has kept the respect of the high-end markets in the United States, European Union, and Japan (beth811.hubpages.com).

Filipino handicrafts are also exported to France, Italy, Malaysia and Taiwan (www.pchi.com). The Philippine Exporters Confederation Inc. Philexport (www.philstar.com) reports that in 2012 the local handicraft industry earned the country \$130 million in sales. The strategy in use for higher sales is aimed at developing more varieties of indigenous raw materials used in producing handicraft products and to maximize their utilization (www.philstar.com).

Today's trends in handicrafts demand the highest level of craft excellence so as to be distinguished as a benchmark for craft production. Asian producers have an international panel of experts, nominated by UNESCO that evaluates handicraft products submissions based on meeting all four criteria. These include excellence, authenticity innovation and marketability. The UNESCO craft excellence award also emphasizes on the product and processes being eco-friendly and fair (www.unescobkk.org).

The bulk of Africa craft products have been sold through traditional Fair Trade channels such as world shops and solidarity niche markets where consumer attitude was based on solidarity with the producers. There has been a high degree of leniency to compliance with quality standards. African handicrafts over the years sold to international markets despite of their low quality. The solidarity markets overlooked other delivery standards (lead times, volumes, and price) that apply in the mainstream markets. The markets are now changing and are unable to tolerate these inefficiencies among producers (www.cofta.org).

World markets opt to buy better quality handicrafts from Asia that are better priced. Philippines handicrafts were considered a relevant learning example to the Kenyan handicraft sector. Their production is guided by standards given by national institutions and international bodies as accreditation for quality. Both handicraft sectors similarly have producers in clusters, using indigenous materials, simple tools, applying traditional skills to produce handicrafts and the production processes are dependent on the producers. However there are disparities seen in both producers as discussed in the literature review. The main purpose of the research was to establish criteria necessary for improvement of quality handicrafts in Kenya. The researcher used qualitative methods to identify, and describe features of leather bags and sisal baskets produced in Kenya. The leather and sisal materials are processed from raw materials grown and processed in Kenya. Specific handicraft products were used as the samples of the larger handicraft producing population.

1.2 Problem statement

It is not known what quality measures and key criteria Kenyan handicraft producers adhere to. Producers as well as consumers have different notions and descriptions on key quality aspects for handicrafts. Some producers have set some guidelines to ensure certain levels of quality are met. The guidelines however vary from one producer to another. The Kenya handicraft industry has few products that are sold in world markets such as the USA and Europe. This is due to the fact that the products do not meet the demand for high quality in those markets. Knock-off and pass-off products are widely available in Kenya. There are other significant challenges facing export of handicrafts like high packaging and shipping costs, ever changing tariffs, lack of patent laws and certifications that artisans have to fulfill to meet market specifications and demanding contracts (Mukami, 2012).

1.3 Purpose/Goal

The purpose of this research was to investigate the factors that contribute to the poor quality of handicraft production in Kenya. The goal was to propose key criteria to ensure the enhancement of quality of products in the handicraft industry.

1.4 Objectives

The main objective of the research was to investigate the factors affecting the quality of leather bags and woven sisal baskets in Kenya.

Other objectives were;

1. To investigate current design attributes for leather and sisal bags.
2. To establish the materials and product realisation process used in production.
3. To propose a criteria checklist for quality production of handicraft products in Kenya.

1.5 Research Questions

The main research question was: What are the factors affecting the quality of leather bags and sisal baskets in Kenya?

The research questions;

1. What are the current design attributes that are essential for quality leather and sisal baskets?
2. What product realisation process and materials are applied in the production of leather bags and sisal baskets?
3. What criteria can be established to ensure production of quality handicraft products?

1.6 Justification and significance of the study

The research project provided information that is essential in establishing craft excellence and benchmarking quality standards of Kenyan handicrafts. Information from the research could be useful to stakeholders including handicraft producers, Government institutions such as the Export Promotion Council (EPC), exporters and researchers. The research contributed to design through the actualization of better products. It opened up more areas for further research such as setting model standards for handicrafts. Controlled product standards and their enforcement would substantially benefit industry and consumers if they were uniformly and consistently enforced. The research could contribute to the Kenya Vision 2030 long-term development blue-print to create a globally competitive and prosperous nation.

1.7 Limitations and assumptions

The research required finances because the case studies were vastly spread from each other. There were limited finances, resources and time to conduct the research.

1.8 Assumptions

It was assumed that the data collected resulted in findings that are applicable to all handicraft products in Kenya. The proposed criteria can be generalised and recommended for use in the production of other handicraft products.

1.9 Scope

A geographic scope was considered because the population of handicraft producers was large and scattered all over Kenya. Handicraft producers in two different major cities Nairobi and Mombasa as seen in figure 1 were selected for the research. This was because they have access to both local and international markets. Selections of three handicraft producer groups were picked as case studies namely Bombolulu Workshops, Bahati Co-operative weavers and Sanabora design house.

Bombolulu Workshop located in Mombasa has been in existence since 1969 and is a programme of the Association for the Physically Disabled of Kenya (APDK). The handicraft producers are physically challenged and have been trained over the years to overcome their challenges to successfully produce handicrafts for local and export markets. The organization was knowledgeable and has had vast experience in handicraft production. In addition, Bombolulu Workshops is a member of Cooperation for Fair Trade in Africa (COFTA) and the World Fair Trade organisation (WFTO). This case study was considered as a critical case in the manufacture of quality handicrafts.

Sanabora Design house was established in 2004 and is a specialist craft enterprise realizing innovative products for various markets. It is owned by a skilled and trained designer who also offers trainings that emphasizes on adherence to fair working practices, creativity, innovation, value addition, quality management and presentation of products. Sanabora is a member of Cooperation for Fair Trade in Africa (COFTA) and the World Fair Trade organization (WFTO). The design house was considered as an expert case study in this research.

Bahati Weavers Cooperative was registered in 2011. It is a group of women weavers who supply their baskets to Kariokor Market in Nairobi, which is one of the oldest craft centers in Kenya. The sisal woven handicrafts produced by the women have over the years been sold locally and exported to various markets. The producers who are mainly from the Eastern regions in Kenya namely Machakos, Kitui, Makeni, are still using the age old traditional methods of weaving to make sisal baskets. The weaving skills and knowledge are passed on to the younger generation by the older generation. Their selection for this research therefore was considered as expert case study.

A product scope was further considered. The research investigated on the leather bags and sisal baskets produced by artisans in the three case studies. This is because the raw materials used by the three case studies were available and processed locally.



Figure 1: Map of Kenya

Source: www.destination360.com (February 2013)

1.10 Definition of Terms

Design Process can be presented into four stages: research, concept, design and production- although the process is messy and these stages are never clearly demarcated and often overlap (Douglas, 2001).

Handicrafts/artisanal products; defined as those that are produced by artisans, either completely by hand, or with the help of hand tools or even mechanical means, as long as the direct manual contribution of the artisan remains the most substantial component of the finished product (UNESCO, ITC,1997).

Jua Kali;the Swahili words for ‘hot sun’, was originally used to refer to artisanal fabrication and repair enterprises that operate without shelter, in kenya it includes many types of informal Micro and Small Enterprises (MSEs) and especially those in self-employment, whether in the open or in a permanent premises (King,1996).

Kiondo is a traditional basket native to Kenyan Kikuyu and Akamba tribes. Before the 19th century, when the *makonge*, (sisal) was preferred for basket weaving use, a variety of plant fibers was used. The Kikuyu used *mugumo*, *mugio* and *murinda* fibers while the Akamba used *mukiswa* and *kindiio* fibers. Today they are found everywhere,seen the use of various fibers to its production a casual innovation with pleasing results (Lambretch, 1981).

Producers/Artisans are people who make products manually (hand or using hand tools); they usually work individually, but can often be helped by family members, friends, apprentices or even a limited number of workers, with whom they are in close personal contact (ITC, WIPO, 2003).

Traditional Knowledgeis traditional-based literary, artistic or scientificworks; performances, invention, information and all other traditional-based innovations and creations resulting from intellectual activity in all fields. It includes medicinal knowledge, ecological knowledge, agricultural knowledge and scientific knowledge (ITC, WIPO, 2003).

CHAPTER 2:LITERATURE REVIEW

2.1 Overview

Kenyan handicraft products are continually changing with the current needs demands of consumer. Notable changes are in the design processes, skills, materials and machinery that are key to the end product. Handicraft producers are adopting design processes that include expertise of designers with specialised knowledge. They continually improve their skills and capacity building through rigorous trainings. Materials are explored and experimented with while new sources are being discovered and used in production. Handicraft production is labor intensive and the use of rudimentary machinery is evident. Producers modify the necessary tools and machinery to suit their needs and boost production. All of the above factors are in continual transition with ultimate goal of production of better quality products. This chapter discusses a number of issues that are essential in the handicraft industry. The information was gathered from literary sources that have documented on the handicraft industry. The first section is on design, processes and how they relate to handicrafts. The section discusses on the numerous design processes applied in various design disciplines and how some of these processes relate and are adopted in the craft industry. Currently, handicraft producers and designers are adapting to design processes to produce products that meet specific criteria.

The second section discusses market driven handicrafts, producer training and professional intervention. Knowledge, skills transfer and raw materials are very vital issues affecting the production of handicrafts. The various sections discuss how these issues are dealt with today in the handicraft sector both in local, regional and international situations. There is empirical literature that discusses the policies and standards that have been set up and are recognized as quality standard measures for handicrafts. There are criteria used by the organizations and the strategy set to ensure a proper quality and standardization system set in place for the producers. The section discusses on what other handicraft producers are doing to work towards quality standards of handicrafts.

The last section discusses on technical and vocational training both locally and internationally. It reviews the Kenyan vocational training and the Philippines (TIVET) system.

2.2 Design research and handicrafts

According to Tirali(www.tiralidesign.com), many designers are of the opinion that craft and design are two completely distinct fields. The design field is innovative while the craft field is based on existing traditional knowledge passed over from generations. It is commonplace to label something as ‘craft’ object and something else as a ‘design’ object. Emphasis is made on crafts being part of the Indian heritage and identity. Crafts have connections with religion, mythology, folklore and traditions. They are an important instrument to the preservation of cultural integrity. According to architect and industrial designer Tirali (2014) he feels that everyone owes it to posterity to preserve it. Arguably, the skill of the craftsman cannot be replaced by machines. When an artisan creates, he or she leaves a personal imprint on their creation (voluntarily or involuntarily), much like an artist does. The non-uniformity characteristic of crafts is much more appealing than the mundane likeness of machine-made products(www.tiralidesign.com).

Artisans have among them an enormous body of varied hand-skills too valuable to be lost. Over the years, crafts have been a means of employment for many people in India. As crafts progressively lose their value, these people lose employment or move to some other vocation. Encouraging crafts could promote entrepreneurship among the masses which would be a positive for the economy. An important question is raised on what can designers do for crafts? The blog discusses ‘Craft oriented design’ which involves handmade Design products. Designers can educate themselves about the crafts of their country or specific to their region. They can work with artisans to experiment and explore craft techniques. Most designers pride themselves on the ability to work within creative constraints. A challenge expected would be innovating while adhering to craft techniques. Collaboration of designers and artisans would solve the craft – design stand-off and create great products (www.tiralidesign.wordpress.com).

Craft design disciplines (*e.g.*, textiles, ceramics, glass, *etc.*) have been understood as “medium-designated” practices whose values are connected with material artifacts and their creation productions (Rowley, 1997). For a craft designer to be able to work with a material, the technical knowledge of how a craft can be made from it must be acquired. This includes the skills or

knowing the material, techniques and tools. This tacit knowledge is usually acquired through individual practice and observation because it is not necessarily put in words or illustrations.

Industrial designer Bill Moggridge (2007) stated that design thinking harnesses tacit knowledge rather than the explicit knowledge of logically expressed thoughts. Designers have the ability and training to harness the tacit knowledge of the unconscious mind, rather than being limited to working with explicit knowledge. He emphasised that with this, designers are good at synthesizing complex problems with large numbers of constraints. However, it also makes them bad at explaining or defining what they are doing or thinking. They will describe processes and results because they are not consciously aware of their own rationale. Conclusively, designers operate at a level of complexity in the synthesis of constraints where it is more effective to learn by doing, allowing the subconscious mind to inform intuitions that guide actions. This is the reason that design education relies on project based approach of “learning by doing” (www.designinginteractions.com).

Correspondingly, Cross(1982; 1999) states that design knowledge exists in a designing activity, not only in designers, but also in artifacts they create and the processes used to create them (people, product and process). To gain this knowledge is to be involved in the activity. The production of design knowledge thus deals directly with the designer’s production of material artifacts. However, the unarticulated nature of the knowledge seems to limit the dissemination of knowledge to a larger number of practitioners, students, and educators. Mäkelä and Routarinne (2006) also agree that some of this knowledge is also inherent in the process of manufacturing the artifacts. It is gained through making and reflecting upon the making of these artifacts. Thus, the triangle of maker-making artifact seems to provide a useful means through which it is possible to approach practitioners’ ways of knowing.

The exploration of knowledge through making artifacts has brought a new dimension to design research as not only is an artifact created but also documented. It contextualizes and interprets the artifacts as well as the process of making them. This way of creation allows the researcher to elicit reflection in and on their working processes that can be considered new knowledge gained in action (Schön, 1991).

Frayling(1993) divides design research into three different categories depending on the focus and mode of the given task. First, *by research into art and design* he implies that art and design is the subject of inquiry to be looked into, a phenomenon to be studied from the outside. This can be done from various well-established approaches, such as the historical, cultural, social, and technical. *By research through art and design* he proposes that the creative production can be understood as a research method. *By research for art and design* he refers to a kind of research in which the end product is an artifact within which the thinking that led to its making is embodied.

Today, however, the production of creative artifacts and that of knowledge have found their position in academic research. Several discussions on design research, as the cultivation of design knowledge, have demonstrated the possible assimilation of the researcher's production of artifacts into academic research (Frayling, 1993; Laurel, 2003; Barrett & Bolt, 2007).

Designer Cross (1982; 1999) further explains that from earliest times, people have had the creative urge to design. In pre-industrial societies, the activity of designing was closely enmeshed with the process of making. Pre-industrial artifacts were (and still are) created by a craftsman working directly with raw materials; there was almost no separation of the activities of designing and making as there is for industrial artifacts. The pre-industrial craft process contained virtually no (designing), in the sense that we understand the process of design in industrial society. There was no creation of novel forms, nor innovation, nor drawing and modeling in advance of making the artifact. Each new artifact was made as a replica of its forerunner. Each specialist craftsman had an elaborate and very rigid set of rules for the shape of the artifact and of the procedures for making it. The craftspeople had no meta-knowledge of why these rules and procedures had to be obeyed; they only knew that any departure from the rules and procedures was highly likely to result in some failure occurring in the artifact. The craft process produced objects which were extremely well-fitted to the functions they had to perform. They were complex in form and in the integration of component parts, were derived from and adapted to the available materials and manufacturing processes, and were beautiful(www.tdd.elisava.net)

Design theorists such as Alexander(1964) and Jones (1970) who have tried to analyze the reasons for the success of the craft process, have suggested that it worked through a process of artificial evolution analogous to natural evolution. Successful, stable forms were developed over long periods of time by a process of tiny adaptations and retention of improvements. Cross emphasizes that designers today are being forced to reconsider the traditional skills of the designer in the light of the changing technology of design. It is time to take stock of the whole range of traditional skills that the designer employs; not just the manipulative skill of drawing, but the cognitive skills that lie behind it. The products and processes of a technology are linked with each other.If significant changes are expected, there should be re-skilling of design students. Learning should move away from individualistic towards team design procedures, towards openness rather than secretiveness; towards the use of design methods that support the inclusion of everyone who has a stake in the product; and towards a wider, collective accountability for the implications, side-effects and other results of design processes.(www.tdd.elisava.net)

2.3 Design processes in craft production

The process of design can be presented into four stages: research, concept, design and production- although the process is messy and these stages are never clearly demarcated and often overlap as seen in figure 2.1 (Douglas 2001).

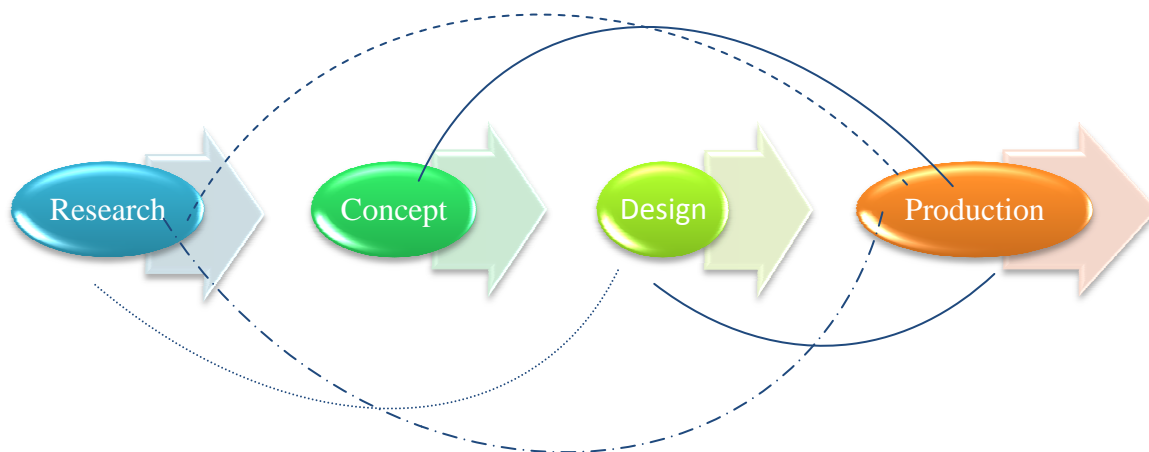

Figure 2.1: Design process as proposed by Douglas (2001)

Source: Douglas, 2001

In comparison, Roy (N.D.) states that in highly simplified form, a complete process may be thought of as consisting of three stages (see Figure 2.2). The process is a dynamic one with the total effect of which is to change the situation in the world. The process involves back tracking between the various stages. Conventionally, stage one which is exploring the world situation, deciding what problems need tackling and what products need making. It is described by such terms as policy making, planning and management. Only subsequent stages, following the identification of the problem are usually described as designing. Arguably, the first stage which encompasses research is part of the design process. Similarly, these three stages deal with the aspects dealt in the four stage design process as described by Douglas (2001).



Figure 2.2: The simplified dynamic design process defined by Roy (N.D)

Source: Roy, (N.D)

Traditionally, artisans usually worked independently. They conceived an object and then using specialized artisanal or technological skills, fabricated it by themselves or with a few assistants in a small studio. By studying the stages of design, it can be seen that some of the activities undertaken by the industrial designer are the same as those of the artisan. The goal of the former usually is reproduction while that of the latter is limited fabrication in one or a few copies. The making of models, molds and prototypes by the industrial designer follows many of the same processes that the artisan uses. The two disciplines come most closely together at this point in the process through similar exact working of materials, regardless of whether it is done by hand machine or computer to create a single example that reflects all aspects of the creative effort. The design process starts with the preparation of a brief. Generally designers work within a written

design brief given by the client, or ideally shaped in conjunction with them. The brief summarizes what is required for the development of a product, such as functionality, form, usability issues and performance and technical aspects. It also specifies any important constraints as well as environmental regulations and legal terms related to the product. Design processes are continually changing. The rational design process (see Figure 2.3) is necessary for the achievement of quality end products. Currently, handicraft producers and designers are adapting to design processes to make products that meet the specified criteria (www.artisanwork.org).

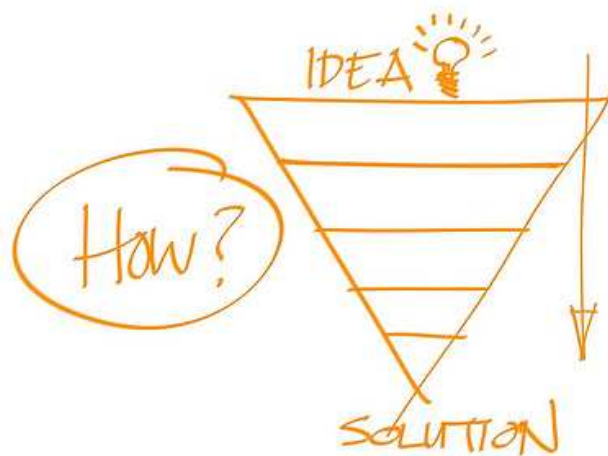

Figure 2.3: Product design process by Artisan work.

Source: <http://www.artisanwork.org>

Aspelun (2012) lays out the design process in seven stage's that include; inspiration, identification, conceptualisation, exploration/refinement, definition/modeling, communication and production. In investigating design processes, Lawson (2006) argues that design in many forms then, deal with both precise, vague ideas and call for systematic and chaotic thinking that need both imaginative thought and mechanical calculation. However, a group of design fields seem to lie near the middle of this spectrum of design activity. The three dimensional and environmental design fields of architecture, interior design, product and industrial design, urban and landscape design, all require the designer to produce beautiful and also practically useful and well-functioning end products. The aspects of aesthetics, practicality and functionality of a product are aspects that can be considered to determine quality. In most cases realizing designs

in these fields is likely to require very considerable technical knowledge and expertise as well as being visually imaginative and ability to design. Designers in these fields generate objects or places which may have a major impact on the quality of life of many people.

The product design process is the conversion of a product concept, described in the product brief, into a functioning prototype. This can be assessed and refined into a viable commercial product. The process is influenced to varying degrees by all the following factors: function, use and maintenance, product dimensions in target markets, international and national standards, Production processes, technology and raw materials. Other factors include; Market trends product style and appearance trends, Price of products in the market and Packaging requirements. The competitiveness of Philippines handicrafts are achieved at a cost. The design of handicrafts would be comparable to the Research and Development undertaken by companies in other industries, and most companies invest a lot of time and effort to stay current in terms of their product designs. It is not unusual for companies to send their designers and artists to Europe and the US just to check out the latest trends in design. The level of technology employed by the small and medium-sized exporters in the Philippines varies depending on the products that they produce. Some products such as basketwork employ simple manual processing and the raw materials used in the industry are mostly indigenous. It is estimated that only 10% worth of non-indigenous raw materials go into the production process (Rodolfo & Teo, 1995)

Arguably, Morris (2009) emphasises that a product needs to be defined not just by a designer's idea or by consumer requirements, but by other considerations too. These could be operational requirements, performance and safety, legal or regulatory functions. These should be captured within the product design specification. Similarly for handicraft products, these aspects are crucial in the design and production. Various aspects such as materials also include availability, sustainability and cost implications. The tools and machinery used in production, their efficiency and outputs are considered too.

2.3.1 Economic gain for design driven handicrafts

Research from a technical paper by the International Trade Center, ITC (2010) on handicrafts and tourism states; many tourists are tired of seeing the same style of animal statues,

masks, traditional cloth among other crafts over and over again. There is not much to discover at many craft markets in the world, just as there is not much variety between products at one shop and the next one. They no longer search for cheap souvenir articles, but prefer some innovative higher, value products. Many tourists prefer products with the design which fits into both worlds; the country they visit as well as their home country. They prefer products to be a nice souvenir and a useful item. Tourists particularly look for items which can be comfortably packed in a suitcase. Therefore, items should neither be too bulky, nor too heavy or fragile.

Viewpoints (2005) mentions a key characteristic of today's global home accessory market is the speed with which trends change. The fashion styles, product designs, and colors transform, resulting in increasingly shorter product life cycles. Producers, in turn, are forced to keep abreast of trends and constantly develop new designs and products. Market experts predict that industry changes will become even more rapid in the future because of instant communications, competition among retailers and wholesalers, and easier and faster travel. This will put more pressure on all producers to deliver product samples and orders quickly lest they go out of style. For developing-country producers, this trend will be a significant challenge and will increase the importance of access to market information and the ability to comply with buyer requirements. These include the quality of materials used for the product. The design of the product should be in line with style trends and the price of the product should be right for the consumers. Capacity of the producer is considered in terms of meeting the buyer's minimum, quantities or maximum quantities. Delivery must be done on time, as ordered, with few major glitches that demand the buyer's time and attention. Business skills such as responsive communication are important for both the buyers and producers.

2.3.2 Cultural heritage in handicrafts

The Global Assessment Report on handicrafts (2006) notes that the market is expected to continue moving away from indigenous (also known as ethnic or traditional) designs toward more contemporary styling. From the same report, product designer Robinson mentions that consumers buy handicrafts because they like to feel connected with indigenous traditions and cultures in a global and increasingly commoditized world. Handicrafts are unique expressions of a particular culture or community through local craftsmanship and materials. While opportunities

for purely indigenous designs may be limited, the potential for products that accent contemporary styling with indigenous elements is certainly not. Labeled as global style, the combination of contemporary and ethnic designs is considered a firmly established and growing category. This presents new and expanding opportunities for handcrafted goods. When enhanced by innovative product development, artisan designs, materials, and techniques can greatly improve the appeal of a contemporary item by softening its textures and creating a unique look.

The growth of the high-end markets presents opportunities for producers to introduce handmade goods with contemporary styling. These markets demand for sophisticated, stylish products from artisans globally. Rather than competing for access to the limited market for purely indigenous products, handicraft producers can adapt traditional designs and skills to complement the broad offerings of the expanding luxury market for larger profit margins. As the luxury market segment grows, consumers have shown a willingness to pay more for unique products. For handicraft producers able to create and deliver quality products at competitive prices, this push to differentiate creates many fresh opportunities. On the other hand, working with new materials and techniques may require additional skills and collaboration among artisan groups. Such cooperation can be difficult; however, especially if different materials must travel between facilities—a small variance at one stage can result in ill-fitting parts at another, increasing production costs, delivery delays, and irregularity among finished goods (USAID, 2006).

According to a case study of Philippines handicrafts to Belgium and Germany in 1995, handicraft products have been an export winner. This is because of the comparative advantages it enjoys in terms of the artistry and creativity of Filipinos. The producers are available in a large pool of well educated, skillful and highly trainable workers in the countryside. They also have a vibrant, cohesive and articulate national association of handicraft producers and traders. The existence of Filipino-owned export trading companies have spurred and expanded production by small, widely scattered handicraft producers. Exporters interviewed in this study have specifically pointed out Filipino creativity in design as the key factor that distinguishes them from their competitors. The Philippines has in fact been labeled as the "Milan of Asia" as a testament to the Filipino's ingenuity and creativeness.

2.4 Skills transfer and apprenticeship

Traditional craftsmanship is perhaps the most tangible manifestation of intangible cultural heritage. The UNESCO Convention of 2003 was mainly concerned with the skills and knowledge involved in craftsmanship rather than the craft products themselves. Rather than focusing on preserving craft objects, safeguarding attempts should instead concentrate on encouraging artisans to continue to produce craft and to pass their skills and knowledge onto others, particularly within their own communities. The skills involved in creating craft objects are as varied as the items themselves and range from delicate, detailed work such as producing a sturdy basket or thick blanket. Like other forms of intangible cultural heritage, globalization poses significant challenges to the survival of traditional forms of craftsmanship. Mass production, whether on the level of large multinational corporations or local cottage industries, often supply goods needed for daily life at a lower cost, both in terms of currency and time, than hand production. Many craftsmen struggle to adapt to this competition. Environmental and climatic pressures impact on traditional craftsmanship too, with deforestation and land clearing reducing the availability of key natural resources. Even in cases where traditional artisanship develops into a cottage industry, the increased scale of production may result in damage to the environment.

Cross (1999) states that traditional crafts are based on the knowledge implicit within the object itself of how best to shape make and use it. This is why craft-made products are usually copied literally from one example to the next, from one generation to the next. The goal of safeguarding, as with other forms of intangible cultural heritage, is to ensure that the knowledge and skills associated with traditional artisans are passed on to future generations so that crafts can continue to be produced within their communities, providing livelihoods to their makers and reflecting creativity. Many craft traditions have age-old systems of instruction and apprenticeship. One proven way of reinforcing and strengthening these systems is to offer financial incentives to students and teachers to make knowledge transfer more attractive to both. Local, traditional markets for craft products can also be reinforced, while at the same time creating new ones. According to Lindblom (1969), it is not very clear who really owns the idea behind kiondo weaving. Information available reveals that it is more associated with the Kamba community. Lack of clear individual ownership of kiondo has left it a property that belongs to communities.

Given that it was created in a local setting to attend to a local need, kiondo seems to fit well as traditional knowledge. This is knowledge passed on from generation to generation by human communities. In response to urbanization and industrialization, many people around the world enjoy handmade objects that are imbued with the accumulated knowledge and cultural values of the craftspeople and which offer a softer alternative to the numerous 'high tech' items that dominate global consumer culture.

Morris et al.(2006), argues that the dominant trend is toward mechanized production of handmade goods in order to lower unit costs and thus be competitive with industrially manufactured products. Many view this as the future of crafts. Mass production can also mean beautiful wares for the masses; the introduction of machinery and assembly line methods to the production process does not necessarily erase their unique character. Customers value functional articles that possess, style, quality materials, and good craftsmanship along with practicality. Further legal measures, such as intellectual property protections and patent or copyright registrations, can help a community to benefit from its traditional motifs and crafts. Legal measures can encourage craft production; for example, a local ban on wasteful plastic bags can stimulate a market for handmade paper bags and containers woven from grass, allowing traditional craft skills and knowledge to thrive. In other cases, trees can be replanted to try and offset the damage done to traditional crafts reliant on wood for raw materials. In some situations, legal measures may need to be taken to guarantee the access rights of communities to gather resources, while also ensuring environmental protection.

2.5 Raw materials for handicrafts

Handicrafts products from Kenya are produced from numerous materials. Materials such as wood, stone such as Kisii soapstone, bone, horn, leather, plant fibers', clay/ceramics, glass and an assortment of beads are used skillfully to make products. Recycled materials such as paper, plastics, rubber and soda cans are also in use today. The waste is actualized as handmade products with the aim of curbing the waste menace. Raw materials such as leather and plant fibers' are readily available to handicraft producers in Kenya. The leather is locally processed to a variety of quality finish for use in the local and export markets. A plant fiber such as sisal

is grown in Kenya. The fiber is processed for a variety of uses both locally and internationally. Leather bags produced in Kenya boast of using the best material processed in the country. Various handicraft centers use the different types of leather that are processed locally. Fashion bags and accessories are made with highly processed leather such as crust whereas traditionally, bags were made from raw leather. The artisans incorporate the latest trends in design with their skills and craftsmanship to come up with new products. More often, artisans incorporate the use of other materials such as canvas and various fabrics to diversify the product range. Some of the popular leather bag producers include Rift Valley leather, Sandstorm and Sanabora.

Sisal bags popularly known as the kiondo/ciondo are made from the sisal plant that is laboriously hand woven in a traditional style. Sisal basket weaving is a rich culture among the Kikuyu women from the central province of Kenya and the Akamba women from the Eastern Kenya. Other ethnic communities like the Taita in the coast province do make similar baskets but mostly from Baobab tree. Most of these weavers are middle aged women. It is a skill that is acquired from other women artisans within their respective community mostly in rural areas (www.craftofafrica.org).

Sisal bags are to date hand woven and traditional skills usually are incorporated with the trend demands to come up with new products. Traditionally the kiondo was woven in the round shape but today there are various shapes that have been adopted to suit the market trends. The main material of use in basket weaving is sisal. Kenya produces the world's best quality Sisal fiber. It is mainly used in the manufacture of high quality and premium products including high quality carpets, specialty paper, gypsum blocks and composites in addition to the traditional baler twine market. Traditionally the main market for Sisal fiber has been baler twine, ropes, sacks, carpets, cordage, and upholstery. Informally, large volumes of Sisal are absorbed in the small-scale handicraft industry annually to make mainly woven bags (Kiondo) among a variety of other handicrafts (www.epzakenya.com).

Currently as seen in the handicraft markets, there is innovation from other artisans of other materials such as polythene that are in use in place of sisal fiber. Manmade fibers such as wool

and nylon are incorporated with the sisal fibers as part of the weaving design of the kiondo. Materials such as leather and wood are used to make handles for the bags. Developments in various uses for products, changes in market trends and technology have brought with them endless possibilities for new products.

2.5.1 Leather production and handicrafts

According to The Leather International 2012 report, the hides, skins and leather industry contribute an estimated 4% to agricultural GDP in Kenya. In the local market the dealers were estimated to earn about Kshs1.8 billion annually, while in the export scene the country earns approximately Kshs4 billion from the exports of hides, skins, leather, leather goods and footwear. However the optimal growth of the industry is purely dependent on value addition. Kenya leather exports amounted to about Kshs 5.9 billion in 2010 while leather goods exports are minimal. In the report, Dr Mwinyihija argues that figure would have been much higher if there was more value addition. His statement is further emphasised by The Economic Survey 2011 Report that mentions the leather and footwear subsector having registered a growth of 6.7% in 2010. This was caused by a 23.9% increase in the production of finished leather (Mwinyihija, 2003).

Until recently, however, value addition in the livestock sector has been minimal, and most of Kenya's exports have been in the form of unprocessed, raw hides and skins. The government's strategy to develop the leather industry springs from its Vision 2030 Program which promotes industrialization and value addition in key sectors. The hides, skins and leather industry are one of Kenya's main agricultural sub-sectors that can contribute to economic growth through expanding exports of both semi-processed and finished leather goods.

The potential for growth in Kenya's leather industry is considerable. The government estimates that value addition could more than double earnings to Kshs9 billion. According to Muriuku of the Leather Development Centre, it is estimated that if Kenya produced leather from all its hides and skins, earnings could rise fourfold to around Kshs 16 billion (€144 million), and directly employ around 10,000 people. In the Kenya Leather Development Council strategic plan of

2010-2015, there is a preview on footwear and leather goods industry. In consideration to the chain approach to the leather industry, footwear and leather products sector is deemed to be a third level. In effect raw hides and skins and the tanning sectors are considered as first and second levels respectively. The qualitative impact to the effect of raw hides and skins and the tanning phases has a direct bearing on the leather products. As mentioned in their strategy matrix, the goal of market development is to facilitate product development and branding. The development of appropriate brands and standards for branding leather and leather products ensures the use of high quality of leather.

2.5.2 Sisal fiber and the Kiondo

Sisal is a vegetable fiber extract from leaves of an Agave (*Agave sisalana* Perrine), a major tropical fiber used in agricultural and parceling twine of various kinds in addition to ropes, sacks, carpets, and upholstery. Agave is a genus that includes the common sisal (*A. sisalana*) and many other species such as *Agave fourcroydes* (Henequen). The Agaves are indigenous to tropical and sub-tropical regions of Southern America, Mexico, Southern Coast of United States of America and the Caribbean Island. It was introduced to Tanzania by a German agronomist in 1893 who imported bulbils from Florida, USA. From there, sisal spread to Kenya and other parts of East, Central and Southern Africa. Sisal is the most important of the group of hard fibers, which includes Flax, Abaca, Jute, Coir and other fibers. Sisal occupies 6th place among fiber crops, representing 2% of the world's production of plant fibers (plant fibres provide 65% of the world's fibers). The world's largest producers are Brazil, China, Mexico, Kenya, Tanzania and Madagascar. Sisal is a reasonably drought tolerant crop and can be grown in areas with as low rainfall. Traditionally the main market for Sisal fiber has been baler twine, ropes, sacks, carpets, cordage, and upholstery. Informally, large volumes of Sisal are absorbed in the small-scale handicraft industry annually to make mainly woven bags (Kiondo) among a variety of other handicrafts.

In 1940s came the invention of manmade (synthetic) fibers. The frenzy that followed this new invention saw a very swift shift from natural fibers to manmade fibers. The proximity to market at a cheaper price and in abundance enabled the new fibers to replace the natural fiber market. This

marked a turning point in the success and growth of the sisal industry with demand and subsequently prices of sisal fiber growing at a much slower rate. By late 1960s demand for Sisal fiber declined causing a consequent declining trend in production, which persisted up to late 1980s. Development of new uses and markets in recent years has reversed the trend. The new uses include the manufacture of composite, particularly for manufacture of interior motor vehicle panels to replace glass fiber, manufacture of gypsum blocks for building and specialty paper. With entry of these new products into the market in the early 1990s, the trend changed with demand and prices for Sisal fiber rising gradually. In the late 1990s, introduction of new uses (products), markets and application of improved production and processing techniques further accelerated the rise in demand. Kenya Sisal Board runs a fully-fledged Sisal Inspectorate unit, which inspects and certifies all Sisal fibers to ensure conformity with established quality standards. The Kenyan Sisal Industry has embarked on an expansion programme to increase Sisal production to meet an increasing demand for high quality fiber (Kenya Sisal Industry 2005). Thus the fiber used for the production of Kenyan baskets is of assured quality.

The kiondo which is a traditional basket native to Kenyan Kikuyu and Akamba tribes has seen the use of various fibers to its production. Before the 19th century, when the *makonge*, (sisal) was preferred for basket weaving use, a variety of plant fibers was used. The Kikuyu used *mugumo*, *mugio* and *murinda* fibers while the Akamba used *mukiswa* and *kindiio* fibers. The traditional material that is still known to be in use is the finely chewed baobab string, *muambwa*, used by the Akamba weavers living between the towns of Makindu and Mutito-a-Ndei in Ukambani. Even so the baobab baskets are scarce. With the introduction of manmade fibers in the 1940's, a nylon thread known as Manila, imported from Korea and acrylic yarn substituted for the sisal and other natural fibers. Plastic woven kiondos from Kenya were already making an appearance in the United States in the 1980's. No one exactly remembers when synthetics first appeared, but many Kenyans say nylon baskets were not seen in the streets, nor were they sold in craft shops before 1966. Today they are found everywhere, even in the Pokot interior and Maasailand. It all began, in a haphazard way. A weaver having a bit of bright red nylon thread on hand incorporated a few single strands of it in her sisal basket- a casual innovation with pleasing results. Weavers subsequently adopted nylon and adapted basketry to it (Lambretch, 1981).

2.6 Policies and benchmarks on handicraft quality

Information is gathered on the existing policies and benchmarks in place in handicraft sectors such as the UNESCO excellence criteria for handicrafts. There are policies that have been put in place to assist the handicraft sector. Countries like Philippines and Asia have institutions in place catering for various needs. The Philippine Chamber of Handicraft Industries, Inc. (PCHI) is a non profit, non-stock organization of traders, manufacturers and exporters of Philippine handicrafts. It was established to showcase the creativity, talent and it supports the promotion of handicrafts. Producers get to continue with production through financial support from the PCHI. The handicraft in itself is developed, allowing people to learn more of the skills involved in production. Capacity building is made possible through trainings and product output is enhanced (www.pchi.com).

In Asia, the ASEAN Handicraft Promotion and Development Association (AHPADA) was formed to establish standards of quality and enhance international market awareness of handicrafts from the 10 Southeast Asian countries. AHPADA supports the fulfillment of its objectives through the sharing of ideas, know-how and experiences. It oversees on the use of resources and expertise in the region for the preservation and the development of craftsmen. The organization aims to promote quality craftsmanship of handicraft products. At the same time, AHPADA supports the development of crafts through different training initiatives. It is involved in the establishment of crafts businesses related to cultural tourism, and the vocational training of youth and handicapped people (artncraft.indiabizclub.com).

In 2001, the AHPADA collaborated with UNESCO and formed The Award of Excellence for Handicrafts (formally known as the Seal of Excellence) that recognises craft excellence. Using the benchmarks set with prior knowledge of trainings, resources and expertise of the producers the benchmarks of quality are unanimously agreed on. The award serves as a quality control mechanism and marketing device that guarantees excellent quality of hand-made traditional and/or innovative craft products from the region. The award is therefore not a prize for a competition given for the most outstanding piece, but a “stamp of approval” that guarantees that a handicraft product or product line meet the highest standards of quality. The product is assured as having been produced with careful regard to cultural authenticity and environmental

conservation. The award programme was established to encourage craft-workers to use traditional skills and materials so as to ensure the perpetuation of traditional knowledge and to preserve cultural diversity (www.unescobkk.org).

The programme aims to establish rigorous standards of excellence for handicrafts. It encourages innovativeness while seeking to promote continuation of traditional skills. It offers training and support services to craft producers in the improvement of their product design, production and marketing, and protection of their intellectual property rights. Producers are provided with market opportunities to ensure sustainability of handicraft industries. In order to be qualified for the award, handicraft products must satisfy all of the following criteria:

1. **Excellent:** The product must demonstrate standard-setting quality in craftsmanship.
2. **Authentic:** The product expresses cultural identity and traditional aesthetic values.
3. **Innovative:** The product utilises creativity in design and production.
4. **Marketable:** The product shows potential for the world market.

Below are some examples of handicrafts that have won the award. The basket in figure 2.4 is from India and was awarded the Excellence award for 2012 as per this criteria. A unique adaptation of the kottan into a contemporary double-layered fruit basket using two techniques of weaving; one technique is called *sohi*, which is comparable to embroidery done with palm leaves. The International 2012 Panel of Experts commended the fine execution of the traditional *sohi* technique, embroidery with palm leaves, and praised the use of the double layer which strengthens the basket (www.ahpada.com).



Figure 2.4: Hand-woven Palmyrah leaf Chettinad 'Kottan' basket

Source: www.ahpada.com (February 2013)

Figure 2.5 shows a Bridal Jewellery Box from Bangladesh made of red sheep leather, with *nakshikantha*, a traditional embroidery technique and decoration on the top. The International 2012 Panel of Experts praised the very fine execution of the traditional *nakshikanta* embroidery, enhanced by the bright red color, the neat finish and the practical multiple compartments.



Figure 2.5: Bridal Jewelry box from Bangladesh

Source: www.ahpada.com (February 2013)

In addition to the criteria, the products have to comply with two underlying conditions. First, the product must be **Eco-friendly**. That is has respect for the environment in materials and its production techniques. The second is **Fairness** that ensures no labor law was violated and no individual or group exploited unfairly in the production of the handicraft. By participating in the programme, craft producers benefit in various ways. Each product recognized with the UNESCO award is given a certificate. The certificate can be used as a promotional tool to attest the quality and authenticity of a product. Producers benefit from Training and capacity-building. UNESCO assists national and sub-regional partners in organizing workshops on product assessment, design and promotion for the producers of awarded products and programme applicants. At Trade fairs and exhibitions producers have the opportunity to display the awarded product at annual exhibitions and fairs and will receive guidance about participating in international trade fairs. Producers benefit from communication and promotion coordinated by UNESCO and its partners. Promotional materials, such as brochures and catalogues, enhance the product visibility and acknowledgment. All awarded products, together with producers' information data, are listed on the UNESCO Bangkok website so that interested buyers can directly communicate with producers. In regards to Intellectual property and copyrights, producers of the awarded handicrafts are sensitized on the benefits of registering their products under intellectual property rights regimes (www.ahpada.com).

By setting quality standards for handicrafts, raising international awareness and promoting innovations to keep the products relevant and competitive, the Award aims to strengthen the interest for these crafts. Capacity-building and promotional activities also help artisans sustain a more viable livelihood and long-term employment. The success of the programme in South East Asia has led to the expansion of the Award programme to not only Central, South and East Asia (see figure 2.6), but also in countries across Latin America, the Caribbean and West Africa. The AHPADA has been successful to identifying the quality standards that have set criteria and is mutually benefit to both the producers and consumers of Asian handicrafts. Expectations are met, standards are maintained and production processes as well as the environmental concerns are also adhered to. Trainings to meet all of the set standards are also offered with the aim of producers meeting the market requirements. The AWARD programme ends up working successfully even in the sale of handicrafts to the international markets (www.unescobkk.org).

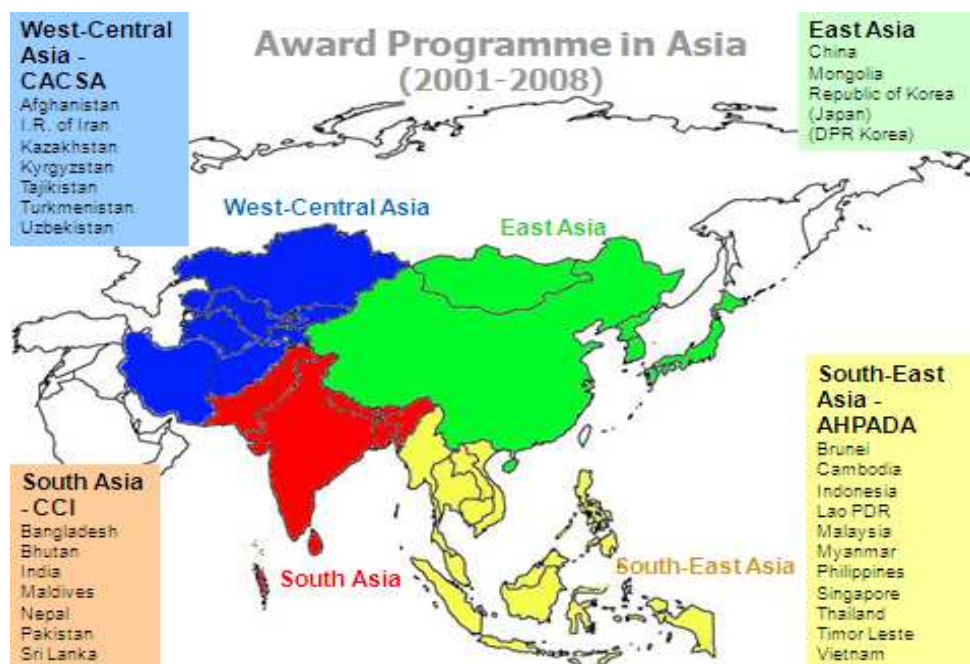

Figure 2.6: Countries in the AWARD programme in Asia.

Source: www.unescobkk.org (October 2012)

India compares its domestic situation on quality standards against the success of AHPADA. Currently in India, there are no quality standards applicable to handicrafts. This poses a problem for the buyers, as it would necessitate personal inspection of the quality of products. To counter this producers suggest that quality standards need to be imposed in certain areas. Raw material usage should be monitored for quality as well as quantity in which they are used. This involves identifying and nominating authorized suppliers. There should be standardization of processes, for machinery and operations as well as the skill level of the artisans. In Production it is essential to impose a certain degree of mechanization to achieve certain minimum standardization levels. It also ensures adequate supplies and helps keep delivery schedules. Indian handicraft producers argue that quality standards for the finish in handicrafts are one of the hardest things to impose. This is because the parameters for evaluating the finish of a product are highly subjective. The proposal of quality checks is suggested to be done only after a prototype for each product is developed. The finished product is weighed against this prototype and rated accordingly. It is essential to stipulate standard packaging material, to make the products more presentable and hence, more competitive. In view of the variety of handicrafts available, development &

imposition of any kind of standards would be a difficult and lengthy exercise. However, if India is to compete in the world market, quality standards will have to be set and maintained (artncraft.indiabizclub.com).

Consumer markets have set certain standards for example in Europe where products have to pass the CE marking showing the products compliance to specified requirements (Kwame, 2006). Fair trade has also established standards to be met for markets in America and Europe. A regional policy such as West Africa Common Industrial Policy under the ECOWAS (Economic Community Of West African States) is in furtherance of activities in its plan for regional integration. It is taking due account of the need for to enhance the endogenous processing of its commodities to enable the generation of goods and services with added value. This is the only way of creating more wealth and contributing significantly to sustainable growth capable of ensuring sustainable social and economic development of the region. It also considers the context of globalization, which requires the region's involvement in global trade by supplying quality services and manufactured products to the market in sufficient quantities (www.ecowas.int).

2.6.1 Professional intervention for craft producers

Although modern society demands that people read and write, African culture continues to teach through the creative mediums of Art and Song. This education must be looked at in depth to establish how useful they can be in future. According to The South African Craft Industry report (1998), many rural South Africans have a low level of education and poor literacy and numeric skills. With poor education and only survivalist literacy skills, there are very few entry points into the economy for people to earn an income. The craft industry is one of the few entry points available to South Africans presently excluded from the formal economy. Such opportunities are both essential and limited for rural communities. The craft groups are then able to develop their skills through experience, apprenticeship, mentoring and the like. In this sense craft activity acts as a low cost training "school" for skills which can be later utilised in the formal sector. The system of apprenticeships is still very much in use today. Young people who want to learn the trade in the craft sector, and often prefer the idea of earning a living for themselves while they study their trade theory part time. During the 19th century, the growth of various crafts was

assisted by the formation of Crafter's Guilds which attempted to regulate certain standards within the various craft sectors. This gave crafters access to valuable skills resources through setting training standards and organizing apprenticeship programs which not only provided trainees with the means to acquire the skills they needed, but also provided the industry with a valuable inexpensive labor pool that was eager to work and learn new skills. Crafting skills are learnt in a number of different ways. These include formal art education; education in general such as high school or primary school; inherited cultural or familial traditions; apprenticeship; informal courses and training programs, as well as through observation. There are few institutions dedicated to training people in crafting techniques and skills.

According to Julia Kukard an Export Consultant in the Western Cape South Africa, most skills training occurs either informally or through short courses/workshops. These are run by various organisations or individuals. In addition there are other Non-Governmental Organisations and Community Based Organisations service providers who may provide craft training in combination with their core service in response to perceived community needs. The Human Sciences Research Council's (HSRC) online directory of training bodies around South Africa lists another twenty-eight different organizations involved in the training of garment making skills and sewing alone. It is notable that most job-creation type craft training is provided at a very low level and in many cases in an ad hoc way. Training is most often conducted by small micro medium enterprises service providers, who often fail to acknowledge the importance of design in the training, and who measure the success of their projects quantitatively in terms of numbers passing through courses. This means that many training projects produce trainees who are good copyists who produce products with a very short life cycle.

Reviews from the Fair Trade organisation in Africa mention that the Craft sectors in developing countries tend to have poor resource bases. There are limited institutional support structures and are often dependent on international aid to build the craft sector in the first place. When it comes to retailing goods, countries are again dependent on the markets in the US, EU and, to a lesser degree, the East to sell their products. This places producers of craft in developing countries at a distinct disadvantage when it comes to participating in the international arena. The barriers to growing the craft sector in developing countries are linked to access to raw materials, skills

development, information, finance and support services. In addition, problems related to marketing, infrastructure and production also exist. The issues that are significantly impacting on the ability of the craft sector to expand include production capacity. There is inconsistency in product quality, poor production and product development to meet the market desires and production volumes. Producers have challenges with raw materials, tools and equipment; there is a need for means of accessing and sharing suitable equipment and materials in order to make the production process as efficient as possible. Producers could also take to buying their materials collectively, as a unit they will have strong bargaining power, whereas individually they are at the mercy of their suppliers.

Skills' training is required in many areas e.g. Basic business skills, Product development, Production techniques in finishing of goods, quality standards sourcing of materials and information and Collective Bargaining that requires organizing among producers. In the craft sector there is absolute consensus regarding the skills which crafters lack but the views on how those skills should be acquired differ. Training programs must include; Business skills, Craft marketing, Crafting skills and techniques including product development skills. Professional organizations both local and internationally based are involved in interventions for craft producers. Trainings for product development, capacity building, skills training and business development are offered. An organisation like COFTA (Cooperation for Fair Trade in Africa) has developed a Capacity Building program that provides Business Skills Training and Product Development workshops to members to assist them to improve their business. Africa has great potential and resources for craft and food products production. However, many producers lack capacity to produce quality products and professionally engage in competitive global markets. COFTA is working to develop a stronger program that will provide more specialised training based on assessed needs (www.cofta.org).

Center for the promotion of Imports, CBI which is a Netherlands Based organization offers training at different levels of needs to producers in various countries all over the world. For product development, a three-day CBI exporter training course is done. This course is especially suited for producers that are involved in the manufacturing and marketing of consumer products such as home decorations, accessories, gifts and home textiles. The training includes theoretical and

visual presentations, practical group exercises and feedback sessions. There is encouraged use of guided research and brainstorming in these highly interactive gatherings. After completing this training, participants have practical skills to help plan future ranges. They are able to develop products and new ranges using a step-by-step process. The training ensures that it is understood how design and product development fit into the overall business management process. Producers can plan and implement strategic product and range development to fit their business marketing strategy (www.cbi.eu).

Professional intervention by an organisation such as “Aid To Artisans” has the most comprehensive and relevant training programs in the craft sector. These programs address the needs of artisans, exporters, designers, organisational leaders, government officials and cultural preservationists. “Aid to Artisan” has craft sector training utilising industry experts in the fields of design, product development, marketing, environment and business management. The training provides firsthand experience and uses real field scenarios. “Aid to Artisan” (ATA) University is the first and only online training in the craft sector. This comprehensive online university includes modules on all aspects of developing a profitable craft business. The training in Product development encompasses all aspects of a market-ready product: design, technical production issues, costing and pricing, merchandising, packaging, and presentation. Product development aims to blend global market needs with traditional techniques and indigenous motifs. Their approach is that Product design and development should inspire new possibilities for creative artisan exploration that adds value to their handmade traditions. Through innovation, craft can rise above subsistence into a satisfying and profitable business. The organisation goes further and trains on technical production. Design consultants develop creative solutions to streamline challenges such as raw material preparation, appropriate technology, environmentally sound production methods, and quality control. Producing a sellable product is simply the first step. Producing a product that can be produced again and again with consistent quality, affordable costs, care to the planet, and to the health and well-being of artisans is the full recipe for lasting success. They involve environmental experts to consult on specific issues such as natural dyes, lead-free glazes, and eco-effective processes.

Aid To Artisan has a different approach to the trainings they offer to craft producers. Design Mentoring is also part of the training offered to producers. Design consultants mentor local designers in-person and long-distance to provide market perspective to in-country creative visionaries. When design consultants work side-by-side in an artisan's workshop accompanied by a local designer, their exchange of ideas is invaluable. The exposure of local designers to international market trends is critical to local business sustainability. It allows artisans to be inspired to innovate, design, and produce new products that keep their businesses viable (www.aidtoartisans.org).

The Product Development and Design Center of the Philippines (PDDCP) a technical agency of the Department of Trade and Industry, was organised to help companies come up with new designs. It provides invaluable assistance in product research and development, design education, design promotion, package design and design resource and technical formation. Other professional intervention is when PDDCP is assisted by foreign consultants, including those provided by the GTZ as part of the Philippine-German Export Development Programme (PhilGED). These consultants regularly visit the Philippines to educate local manufacturers about the designs, colors, and finishing currently desired in the foreign markets. The Philippine private industry sub-sector and regional organizations seek to help the handicraft industry members by providing technical and technological assistance, by organising inter-industry fairs and seminars and by providing financial assistance. They are also involved in lobbying for their sector to Center for International Trade Expositions and Missions (CITEM) and other government agencies. The Philippines handicrafts have been quite successful at penetrating foreign markets. Credit for the success of exports goes to the Center for International Trade Expositions and Missions (CITEM), the main government marketing arm for these products. CITEM has not only exposed Philippine handicrafts to the global market through locally held fairs and permanent showrooms, it has also assisted several exporters in joining international fairs and exhibitions, the most prominent of which is the Ambiente in Frankfurt, Germany. Joining international trade fairs has been acknowledged as a good vehicle not only to promote or showcase one's products, but also to test the market and to learn about the market. CITEM also tries to subsidize local handicraft firms' participation in international fairs (Rodolfo & Teo, 1995).

2.6.2 Education and training

There are different types of education and training in Kenya; the formal and informal education and training systems. The current system of formal education is generally referred to as the 8-4-4: eight years of primary school, four years of secondary and at least four years of tertiary education. Formal training includes the technical and vocational training that is offered by institutions. These institutions such as the youth polytechnics and technical training institutes have a structured curriculum and fixed-period programmes leading to certification. Informal sector training involves skills acquisition and apprenticeship that blends imperceptibly into on-the-job training of unpaid or low-paid workers (Walsh 1991). In Kenya there are thousands of secondary school leavers who pass their ordinary level certificate examinations but cannot find employment. Some of the school-leavers joined the informal sector in view of the prevailing unemployment crisis. Because the great majority of those completing secondary school-leavers cannot find employment or enroll for higher education, the informal sector has turned out to be one alternative. The activities carried out in the Kenya informal sector are diverse; furniture making, automotive repairs and handicraft production. The informal sector in Kenya, also known as *Jua kali* (“hot sun” in Kiswahili – since most of them are in the open) is not only a great employer but is playing a big role in wealth creation. Technical and Vocational Education and Training (TVET) is regarded vital in the development of informal sector industries (Mwangi, 2011).

TIVET (Technical, Industrial, Vocational and Entrepreneurship Training) is the Kenyan version of the internationally known TVET (Technical and Vocational Education and Training). It is a comprehensive term referring to pragmatically important components of a national training system. It entails the study of technologies and related sciences, the acquisition of knowledge, practical skills, and attitudes relating to occupations in various sectors of economic and social life. TIVET provides and promotes lifelong education and training for self-reliance. The training programs are expected to provide opportunities for individuals to learn the practical, social and personal skills that will enable them to function at workplaces and as members of society. The programs are also to provide for progress within their occupational area and serve as avenues to further education and training (MoE, Kenya, 2012). One of TVET’s objectives is to develop skills which will be responsive and relevant to the country’s human resources required in production.

Another of its goal is to eradicate poverty. Technical and Vocational education and training (TVET) has always been an important catalyst in wealth creation in all countries. At senior high school and polytechnics, it prepares middle-level personnel and at the university level, engineers and technologists for higher management positions. Public secondary and tertiary schools with technical and vocational education programmes have played major role in preparing workers for informal sector employment (Atchoarena & Delluc, 2001).

Trainees of vocational and technical education are equipped with competencies for specific occupations or productive activities in the various sectors of social and economic life, notably agriculture, industry and commerce. These sectors are very important pillars of wealth creation. Countries that have achieved middle-income status have given special attention to education in general and in particular, vocational and technical education. However, the informal sector operators face a number of problems. These include lack of knowledge of usable technologies, material, design, manufacture, business accounting and administration. Lack of relevant TVET and professional skills are the most critical problems informal sector enterprises operating in Kenya face. TIVET is aimed at enhancing competencies of craftsmen such as handicraft producers in the informal Sector in Kenya. According to a research in the jua kali sector by Mwangi (2011), identifies and confirmed the idea that technical and vocational education and training (TVET) has a lot of potential in the development of the informal sector. Graduates who had undergone TVET acknowledge that it enhances their creativity both in technical and generic skills. The output and quality of goods and services tended to improve with technical and vocational education and training. It recommends the strengthening of technical and vocational education in schools, mostly at secondary level. The Curriculum design developer should involve all relevant stakeholders in the development of a comprehensive national skills training strategy. TIVET urgently requires improvement to make their graduates compliant to industries skill needs that is of particular significance in today's economy. Traditional skills and knowledge could be incorporated into the curriculum and taught as they are an integral part of the handicraft sector.

In comparison, the education and training system in the Philippines embraces formal and non-formal education. Formal education is a sequential progression of academic schooling at three levels namely, elementary, secondary and tertiary education. Non-formal education, which includes the acquisition of knowledge even outside school premises, is aimed at attaining

specific learning objectives for particular clientele who cannot avail of formal education. An example is the functional literacy program for non-literate and semiliterate adults which integrate basic literacy with livelihood skills training. Congressional Commission on Education, known as the EDCOM, believes that the technical vocational education and training (TVET) sub-sector should be made more responsive to the dynamic changes in the local labor market particularly with the ongoing structural adjustments and the changing patterns of trade and competition in the world economy. TVET provides education and training opportunities to prepare students and other clients for employment. It also addresses the skills training requirements of those who are already in the labor market and would need to upgrade or acquire new competencies to enhance employability, improve productivity, or facilitate career shift. TVET in the Philippines is competency-based adherent to certain principles. Training is based on curriculum developed from the competency standards. Learning is modular in structure and training delivery is individualized and self-paced. Training is based on work that must be performed and materials are directly related to the competency standards and the curriculum modules. Assessment is based on the collection of evidence of the performance of work consistent to the industry-required standards. Training is based on both on- and off-the-job components and allows for recognition of prior learning (RPL) or current competencies. The training allows for multiple entry and exit into the job markets and the approved training programs are nationally-accredited. There is continuous development of quality assurance systems and procedures. The supportive of such principles ensures that TVET produces job-ready Filipino workers meeting the requirements of the local and international labor markets (TESDA, 2006).

2.7 Summary

From the information in the literature review there are several macro and microfactors that contribute in the production of quality handicrafts in the Philippines. Aspects such as design knowledge and research, raw materials, artisan skills, apprenticeship and set standards are essential in the production processes. Design Research in handicrafts is overseen by a technical agency, the Product Development and Design Center of the Philippines (PDDCP). The handicraft producers get technical, technological and financial assistance from the private industry sub-sector and regional organisations. These organisations further lobby for them to

government agencies for assistance in attending trade fairs to market their products. Artisan skill training are both formal and non-formal where both systems are certified. The non-formal training integrates basic literacy and livelihood skills. Formal training involves skills transfer and apprenticeship that are attained through TVET. The raw materials used in the production processes are mostly indigenous and the technology is specific to the products. The existing policies and benchmarks for quality of Philippine handicraft products are recognized and accepted nationally and internationally under an authority guided by specific criteria. Handicraft products that meet the required criteria are given a stamp of approval when accorded The Award of Excellence for handicrafts. This guarantees that the product has met the highest standards of quality. The conceptual framework as seen in figure 2.7 is based on seeking to identify criteria to be used in the production process for quality handicraft production in Kenya.

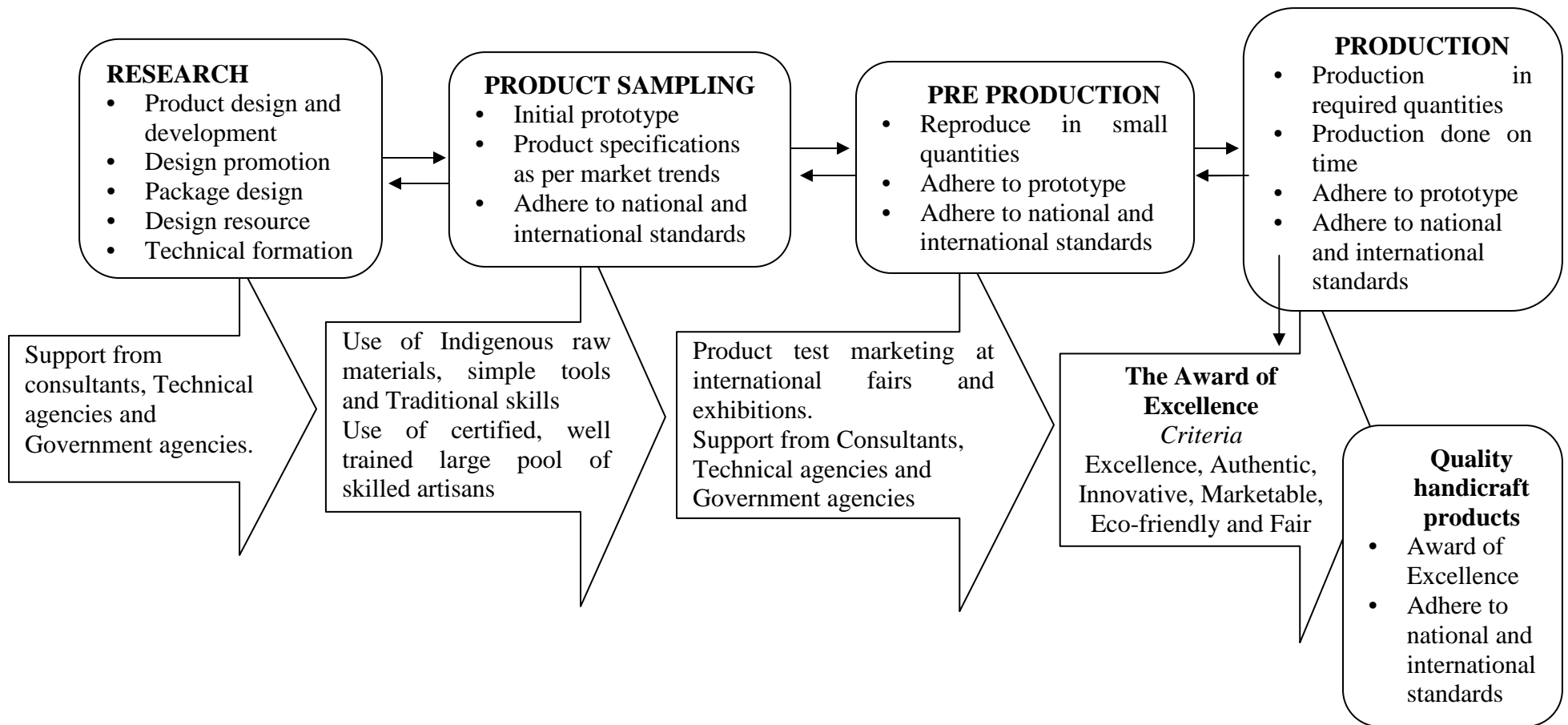

Figure 2.7: Conceptual framework

Source: Kamuiru,2014.

CHAPTER 3: RESEARCH METHODOLOGY

3.1 Overview

The researcher used a population of 185 handicraft artisans who are involved in the handicraft production of leather and sisal bags. The artisans were selected from clusters in the major cities of Nairobi and Mombasa. The handicraft producers have common observable characteristics; the products that they make and the markets for these products. This research involved observations of bag production and its processes in their natural settings. The information was collected in form of detailed field notes, photographs, sketches and producer records. A total of 46 people who include producers/artisans, consumers and professionals in the handicraft industry were interviewed. The information was recorded in descriptive form. The information was presented in tables and descriptive forms. The researcher experienced various challenges while collecting data in the various site of the case studies. Artisans were cautious on revealing information on skills development, period of training and level of education. They also show a bit of restraint and are hesitant in participation the moment the researcher appears with a questioner and is writing down their answers. A solution to this was to explain in detail the objectives of the research in relevance to the production of bags at the workshop. Information on the finances such as sales reports and analysis was considered sensitive and could not be fully disclosed to the researcher.

3.2 Research Design

This was a social research employing normative methods. Information was presented as descriptive rather than numerical thus the research had a qualitative approach. Qualitative research is a generic term for investigative methodologies described as ethnographic, naturalistic, anthropological, field, or participant observer research. It emphasizes the importance of looking at variables in the natural setting in which they are found. Interaction between variables is important. Detailed data is gathered through open ended questions that provide direct quotations. The interviewer is an integral part of the investigation (Jacob, 1988). The data collected is recorded as detailed field notes and is presented in narrative form.

Colloquially a research design is *a logical plan for getting from here to there*, where “*here*” may be defined as the initial set of questions to be answered and “*there*” is some set of conclusions (Yin, 2002). Another way of thinking about a research design is as a blue print of research, dealing with at least four problems: what questions to study, what data is relevant, what data to collect and how to analyse the results (Philliber, Schwab & Samsloss, 1980). The research narrowed down specific handicraft products for the study. The researcher was concerned with exploring the quality of specific handicraft products, leather and sisal bags.

3.3 Population

The researcher considered a population of 185 handicraft producers from workshops in Mombasa and Nairobi, who are involved in making leather and sisal bags. Maina (2012) defines a population as a complete set of individuals’ cases or object with common observable characteristics. The producers were considered as they have common observable characteristics that are informative to the research objectives. The production is mainly skillfully done by hand with the aid of machinery and other handheld tools. The producers have common markets and consumers for their products in the local, regional and international. These bags use leather and sisal, materials that are locally sourced. Bombolulu Workshops and Cultural Center is located in Mombasa and employs 150 artisans in handicraft production. In Nairobi, Sanabora design house, located at Ngara employs 15 fulltime workers who make a variety of Leather products for local and export markets. Bahati Co-operative weavers who sell their baskets at Kariokor in Nairobi have 20 individuals who are directly dealing with the sisal products.

Handicraft producers	Location	No. of producers (POPULATION)
Bombolulu Workshops and Cultural Centre	Mombasa	150
Sanabora Design House	Nairobi	15
Bahati Co-operative weavers	Nairobi	20
		Total=185

Table 3.1: A summary of Population Distribution

Source: Kamuiru, 2012.

3.4 Sampling

Cluster and purposive sampling techniques were used to identify the respondents. When conducting research, quality sampling may be characterized by the number and selection of subjects or observations. Obtaining a sample size that is appropriate in both regards is critical for many reasons. Most importantly, a large sample size is more representative of the population, limiting the influence of outliers or extreme observations. A sufficiently large sample size is also necessary to produce results among variables that are significantly different (Patel, 2011). For qualitative studies, where the goal is to “reduce the chances of discovery failure,” a large sample size broadens the range of possible data and forms a better picture for analysis (DePaulo, 2011). There are many different ways to determine an appropriate sample size. For in-depth qualitative studies, Abbie Griffin and John Hauser found that “20-30 in-depth interviews are necessary to uncover 90-95% of all customer needs for the product categories studied. Thus, the authors determined that a sample size of 30 respondents would provide a reasonable starting point. This number is corroborated by Dr. Saiful, a clinical researcher, who states that a “sample size larger than 30 and less than 500 are appropriate for most research,” adding that sub-samples also require at least 30 observations when applicable (saifulbahri.com)

First, selective cluster sampling was done to select the three handicraft producing groups. This was because it was not possible to obtain a sampling frame because the Kenyan handicraft population was either very large or scattered over a large geographical area. Selective cluster sampling involves selection of an intact group (Mugenda & Mugenda, page 49 2003). Three handicraft producers that were in an intact group were selected from Nairobi and Mombasa.

Purposive sampling technique was used to select the respondents that are informative to the research objectives. Artisans were selected as the primary source of information as they are the involved in the production of the leather and sisal bags. 2 artisans from Bombolulu workshops, 2 artisans from Sanabora design house and 2 weavers from Bahati Weavers Cooperative were interviewed. The designers from each case study were also selected as they are directly involved in the product conceptualisation and actualisation of the products thus informing the researches objectives.

3.4.1 The sample

The sample selected for the research were the particular individuals making leather and sisal bags. Table 2 below shows a summary of the sample selected for interviews for this research. Out of the 150 artisans, Bombolulu Workshops employs 20 artisans in the leather workshop, four artisans were interviewed and these include the head designer, production supervisor and two craftsmen. Sanabora design house that employs 15 fulltime workers, three personnel; the designer, production manager and an artisan were interviewed. The researcher was also involved in observing Bahati Weavers Cooperative group who produce and supply the Kariokor market with sisal Kiondos on wholesale basis. At Kariokor market in Nairobi there are 20 artisans dealing with the sales of sisal bags. 4 of their members were interviewed for this research. In their workstation at Katangi in Machakos, the women were observed weaving baskets and 2 weavers were interviewed. Two other members who were stationed at Kariokor market an artisan and a marketer for the kiondos were also interviewed.

Beyond the sample groups, more information and data was collected from key informants from institutions such as Export Promotion Council, Professionals such as expert designers, marketers, trainers, exporters and consumers who are key players in the handicrafts industry. The information given by the above professionals confirms the primary information collected from the case studies.

No.	Description	Persons to interview	Population	Sample
1	Bombolulu Leather workshop, BWCC, Mombasa, Kenya	designer, production/procurement manager, 2 artisans	150	4
2	Sanabora Design House, Nairobi, Kenya	designer, production/procurement manager, artisans	15	3
3	Bahati Co-operative Weavers, Kariokor, Kenya	2weavers, 1 artisan, 1 wholesaler	20	4
4	Designers in Handicraft industry	product designers,		15
5	Marketers- involved the local, regional and international handicraft sector	- Marketing personnel from the three case studies		3

6	Customers/ consumers- of locally produced handicraft products	- customers of each producer group/ case study		12
7	Institutional people- Export Promotion Council, Government institutions, Export coaching trainer	- 2EPC officials, Exports Trainer, 2 Government officials		5
			Total	46

Table 3.2: A summary of Sample Distribution.

Source: Kamuiru,2012

3.5 Research Tools and Instruments

Probable causes that affect and contribute to the quality of the specific handicraft products were investigated. People’s opinions, experiences and feelings were sought through the interaction with individuals and producer groups. Data collection methods included, naturalistic and participant observation; semi structured and structured interviews, focus group discussions, and the researcher’s impressions. Secondary data was gathered from the perusal of producers’ records in reference to production and sales of bags. Additional information was also gathered from the library where it was retrieved from books, documents, journals and the internet. The data collection tools included photographs and sketches of the products relevant to the research. Visual record of production processes was also done. Information gathered from observation, interviews and focus groups was recorded as detailed field notes. Photographs and sketches were sorted into categories. The data from the field notes were presented in descriptive narrative form. The following tools were used to collect data for this study.

3.5.1 Records and reports from the producers

Secondary sources of data were also be used in this research to gather information. Product development request forms, product information sheets, design briefs and Market records from the producers were referred to for the purpose of gathering information. The researcher used market sales reports from Bombolulu Workshops to gather information on the quantities of leather bags sold both locally and internationally. Design and Trend information was retrieved

from the records such as sketches, product information sheets, and design briefs that were specific to consumer demands. Different clients had different ways of sketching and presenting their requests for the bag samples. The Bombolulu leather workshop also had various catalogues on their range of leather bags that the researcher was able to refer to for additional information (see Appendix F).

At Bahati Weavers Co-operative, the researcher observed the records kept by producers for their Kiondos'. At the points of sale in Kariokor market, there was a member in-charge of noting down how many baskets are in stock for sale and the prices for each. The records are informal and used for personal reference of product stocks and confirmation of sales or a client orders. The sisal basket producers have no evident records on design and current trends. In terms of finances, any records available could not be shared as these were viewed as business secrets. The client orders are also based on verbal agreements and references to available sisal materials and colours.

Records observed at Sanabora design house include various sketches that document the process of product development. The researcher also observed the print and electronic catalogues for the leather bags that documented various designs and range of leather bags (see Appendix F).

3.5.2 Participant Observation

This observation involved intense data collection. The researcher used continuous observation to record everything that occurred in the production of the bags in their natural setting. The researcher used this method with one of the case study groups Bombolulu Workshop where she is involved as an employee. The observation was carried out for duration of two months during an order production for leather bags. The observation for product development was done in the morning hours for two weeks in the first month when the leather designer was working towards a new bag collection. During this period the researcher was able to move around comfortably as being part of the product development team. The information gathered was recorded in form of detailed field notes, sketches and photographs. Mugenda and Mugenda (2003 page 167), state that this method ensures that valid results are given as it is firsthand information. The role is

appropriate when the researcher needs to become totally immersed and experience the work or situation at first hand (Maina, 2012).

A number of 6 artisans were observed during this two month period. Participatory observation was best done when the artisans are not aware that their actions were being recorded and when production was at the peak most periods. There were constant interruptions between the observation periods as the artisans have to so often liaise with the production supervisor on the ongoing work. There were frequent consultations on the artisans' progress though this was never viewed as interference by the researcher. It is part of the process of quality checking of the product so as mistakes are rectified on time rather than later. Other interruptions included the frequent flow of visitors to the workshop on social tours. Bombolulu workshops and Cultural Centre have an open door policy that encourages visitors to see the work as it is in progress. Briefly an artisan will stop his work to explain the current production process they are undertaking.

3.5.3 Naturalistic Observation

The production of bags in their natural settings was done to record and study behavior as it normally occurred. The researcher does not control or manipulate the subjects or the environment in any way, (Mugenda and Mugenda, 2003 page 171). This method of data collection was used mainly in the two cluster producer groups, Sanabora design house and at Bahati Co-operative weavers. In these two case studies the researcher was not be involved in the production process of the handicrafts. Detailed study of the processes was carefully observed. Detailed field notes and photographs were taken. An observation guide was used to aid in gathering of information (see Appendix C).

At Bombolulu workshops naturalistic observation of production of the bags was done in the mid mornings into the afternoon when production was ongoing. This was done over a period of two weeks to gather information that was used to compliment the findings from participant observation.

At Kariokor market in Nairobi, the researcher observed the weavers who have points of sale for their sisal kiondos. The researcher noted that the basic process of weaving of the sisal baskets was not done on site at the Kariokor market. The sellers interviewed explained that the market gets an assortment of sisal kiondos from Machakos, Makueni, Kitui and a few from the central regions in Kenya. The Bahati Weavers Co-operative from Machakos supplies the market with Kiondos. It was also observed at the market that almost all the kiondos that were brought into the market did not have handles. The various ways of finishing of the kiondos' was done by artisans at Kariokor. The finishing includes stitching leather straps, stitching of lining and zippers and beading of the kiondos' brim with glass beads. The researcher was thus involved as an observer over a period of one month at Bahati Weavers Cooperative in Machakos and at Kariokor market. Their production processes were observed at their workspace and was recorded in detailed field notes and photographs.

At Sanabora Design House, the researcher was involved in naturalistic observation of the production processes. For a period of one month, the artisans were observed at their workshop as the production processes were ongoing. The various activities were recorded in notes form and photographs were also taken. The researcher also observed the Sanabora sales activities at various points of sale as consumers interacted with the sales team as they bought the leather bags.

3.5.4 Interviews

Respondents who were interviewed include producers, marketers, purchasing personnel and consumers of handicraft products. In the first case study at Bombolulu workshops, the following respondents were interviewed; 2 artisans, the leather designer, the production manager, the purchasing manager, the marketing manager, and 4 customers. At Sanabora, 2 artisans, the production manager, Head designer/Director and four customers were interviewed. At Bahati Weavers Co-operative and Kariokor market, 2 weavers, 2 wholesalers and four customers were interviewed (see table 3.2 for summary). An interview guide for producers was used to interview the leather designer and artisans and a specific interview guide used for consumers (see Appendixes' A and B).

There was hesitation to answer some questions in regards to designs, pricing and sourcing of materials was also experienced. This is mainly because of the Design exclusivity agreements that the producers have with their clients. For two of the case studies, Bombolulu Workshops and Sanabora Design House, certain aspects of the information were withheld by the interviewees. Example in reference to material sourcing, there are details that the purchasing department considered as trade secrets. Detailed information on tabulated sales could not be availed by the weavers at Kariokor market. Some challenges were overcome at Bombolulu where the researcher is a member of staff and the information required was given at discretion. The data gathered was recorded in detailed field notes.

3.5.4.1 Unstructured interviews

In the in depth interviews, general questions were asked and the respondents were encouraged to talk freely. The interviewer uses an unstructured format, the subsequent direction of the interview being determined by the respondent's initial reply (Maina, 2012). The researcher selected this method of data collection so as to avoid giving leading questions that would have restricted the respondents' answers. Respondents who were interviewed using this method include the handicraft producers/artisans.

In the case study of Bombolulu, the researcher used this method and an interview guide (see Appendix A) was used to interview the artisans. Two artisans involved in production spoke at length with the researcher on their day to day production processes, their skills and training. The information gathered was recorded in detailed field notes.

At Sanabora Design house interviews were held with the production manager who explained at length on the process of production followed. Information on the skills and training acquired were explained in detail by the artisansinvolved in production.

At Bahati Weavers Co-operative, 2 people were interviewed using this method and the interview guide in Appendix A. Individuals interviewed were the artisan involved in finishing kiondos and a wholesaler based at Kariokor Market. They also are the marketers of the kiondos sourced from Bahati Co-operativeweavers. During the interviews they are able to answer the question as they

are producers themselves and are familiar with the production processes of weaving and finishing. The wholesaler was reluctant in giving specific details that relate to finances as these were viewed as business secrets.

3.5.4.2 Semi-structured interviews

Interviews are focused by asking certain questions but with scope for the respondent to express themselves at length (Maina, 2012). The researcher used an interview guide to ask the questions relevant to the research objectives. The data was gathered through face to face encounters with the various respondents. Respondents who were interviewed using this method included professionals such as designers and marketers from the three case studies, exporters working at the Export Promotion Council and designers involved in Handicrafts. Interview guides with guiding questions (see appendix B) were used according to each designation of the interviewee. This method was appropriate as the data collected was mainly descriptive.

3.5.5 Focus group discussions

Discussions were done in a natural manner which involved a small group of respondents were conducted. They were held among a group of professionals such as product designers and marketers in the handicraft sector. In Bombolulu Mombasa, a focus group of 6 designers met four times and a question guide (see Appendix B) was used to lead the discussions. The group comprised of product designers and marketers in the handicraft sector that are conversant with both the local and international markets that buy the Kenyan handicrafts. For the list of participants see Appendix B. A focus group involving a sales team was held once and it involved 8 members from Bombolulu workshops involved in selling the leather bags. A focus group of designers was held in Nairobi in August and discussions were based on the findings of this research. Using the researcher as a moderator, the discussions focused on the research objectives and guiding questions (see Appendix B) were used to guide the discussions. Data was recorded as detailed field notes. A summary of issues arising from each topic discussed were presented in table form. The issues were compared among the three case studies in the data analysis.

Objectives	Data needs	Data sources	Method of collection	Method of analysis
Identify characteristics of leather and sisal bags	Profile of leather and sisal bags	<ul style="list-style-type: none"> • Craftsmen • Artisans • Consumers 	<ul style="list-style-type: none"> • Ethnography • Naturalistic and participant observation • Unstructured Interviews • Sketches • Photographs • Field notes • Literature review from books, journal and seminar articles 	<ul style="list-style-type: none"> • Descriptive analysis • Data organization into categories.
Determine product realization processes	Product realization processes	<ul style="list-style-type: none"> • Artisans • Designers /production personnel 	<ul style="list-style-type: none"> • Naturalistic and participant observation • Unstructured /semi structured Interviews • Field notes 	<ul style="list-style-type: none"> • Descriptive analysis
Profile the leather and sisal bags producers	Level of education, skills training and experience	<ul style="list-style-type: none"> • Artisans • Craftsmen • Designers • Marketers 	<ul style="list-style-type: none"> • Unstructured Interviews • Focus group discussions • Field notes 	<ul style="list-style-type: none"> • Transcribe field notes • Descriptive analysis
Proposition of a quality guideline model	Quality check list for handicrafts	<ul style="list-style-type: none"> • People:- professionals, consumers, artisans • Product analysis data • Journals and seminar presentations 	<ul style="list-style-type: none"> • Interviews • Field notes • Literature review from books, journal and seminar articles 	<ul style="list-style-type: none"> • Descriptive analysis

Table 3.3: Summary of Data Collection

Source: Kamuiru, 2012

CHAPTER 4 FINDINGS AND ANALYSIS

4.1 Overview

The design and production processes of each case study were carefully observed and recorded in detailed field notes. The characteristic features and designs of the leather and sisal bags from the producers of each case study were sketched. The various production processes, tools and machinery in use were recorded in form of photographs. Detailed sketches of the bags were also drawn by the researcher. The information gathered by the researcher was presented in detailed narrative form. From the field notes taken during participant and naturalistic observation, a descriptive analysis of all data gathered was done. The photographs and sketches were sorted according to different themes. Data collected from profiling of the bags was analysed through product anthropometry. Standardisation of bag sizes was analyzed with the aid of a template. Information and data was cross tabulated according to the patterns, trends and relationships established from the findings of each case study.

4.2 Product attributes of leather and sisal bags

4.2.1 Bag shapes

Bombolulu Leather workshop

The researcher considered the safari collection travelling bags that are made by the Bombolulu leather workshop for this study. The bags are designed from basic geometric shapes. The selected travelling bag has a base shape that is a long rectangle. The bag's main body form resembles an upright trapezoid shape (see Figure 4.1 and Figure 4.15). The shape is achieved from the fact that it is made from a single material cut out and joined by stitching at the sides. The bag design has two leather loops on each of its sides just below the zipper that aid the bag in folding downward and looping to a bone bead at the lower part of the bag. The loop and bead are used to change the shape of the bag. The bags ends that extend out to form the trapezoid shape are folded down by pulling the loops down. The loops are then anchored into the bone beads and the bag is reshaped into a rectangular shape. This gives the bag owner two shape options while using it (see Figure 4.16).

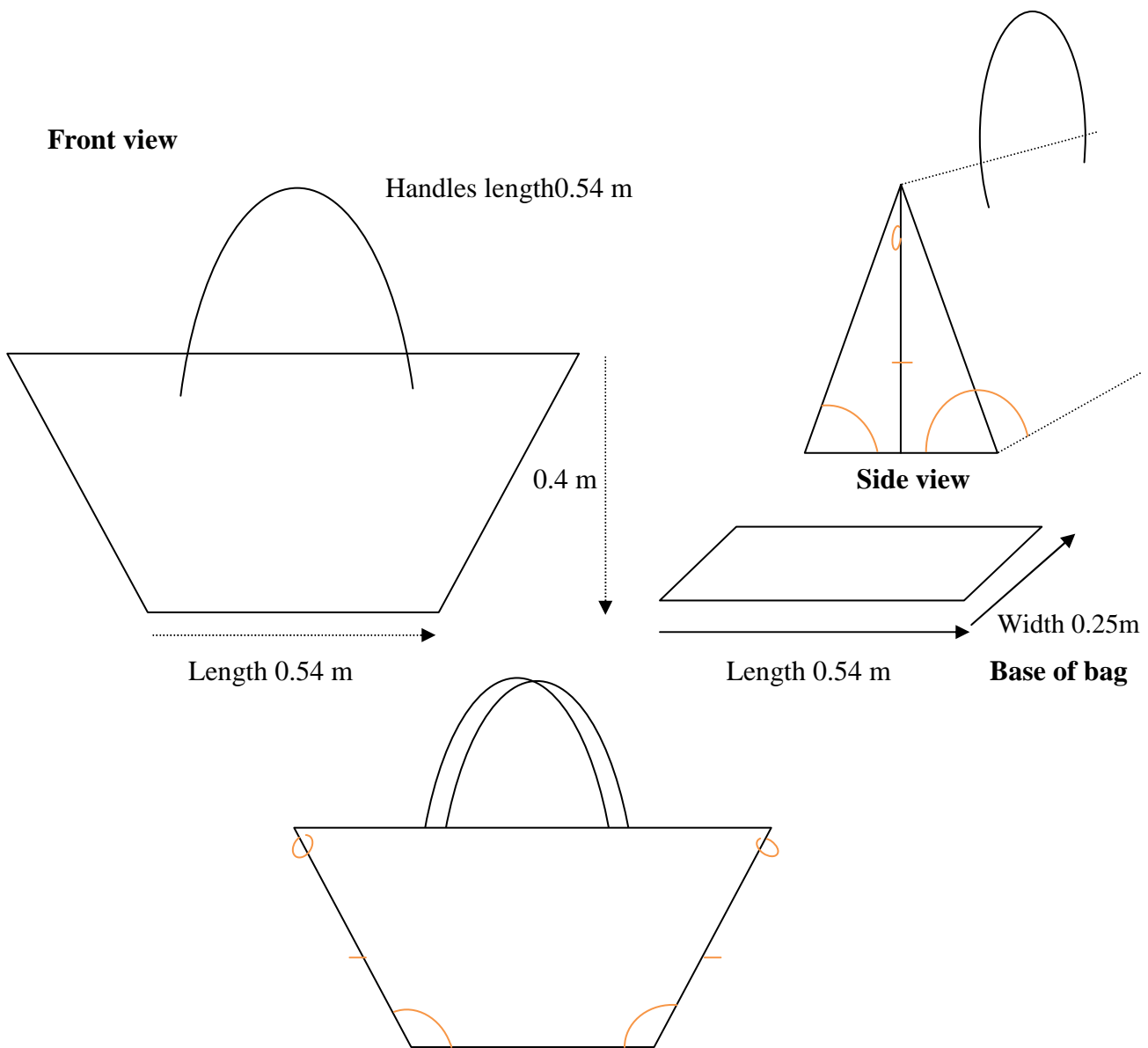

Figure 4.1: Simple sketches showing shapes of Bombolulu's travelling bags.

Source: Kamuiru 2014.

The ladies leather handbag of this range is also geometric. It has the rectangular shape for both its base and that of the main body. It is a single structure bag made from a single piece of leather and it is stitched together at the sides. The smaller size bag has a long triangular shape making it appear longer in length. The larger size of this bag is a square shape that is stitched onto a rectangular base.

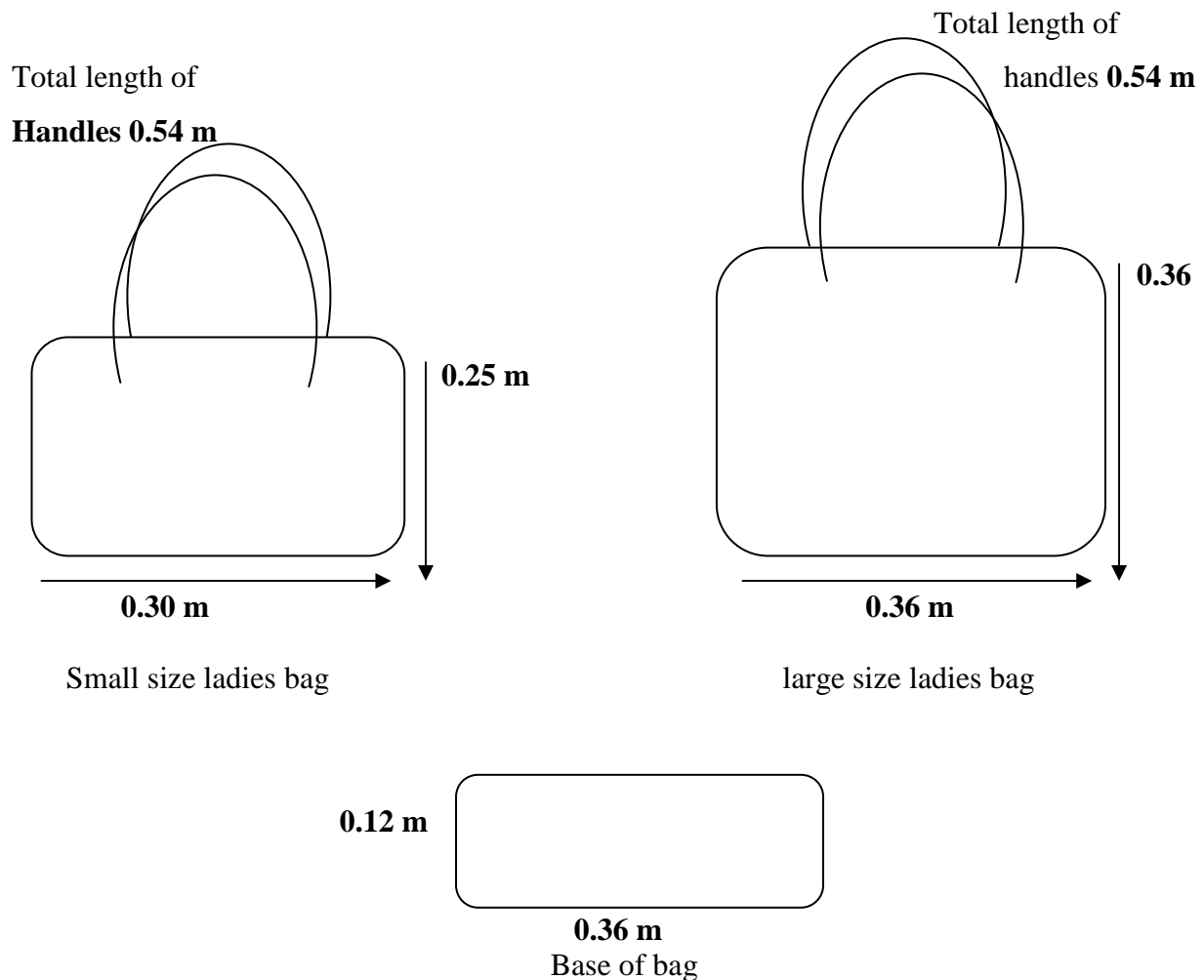

Figure 4.2: Simplified sketches showing shapes of ladies bags from Bombolulu.

Source: Kamuiru 2014

Sanabora Design House

The researcher observed the ladies handbag range that is rated by the marketing team as one the best sellers. The observed bags range was designed from geometric shapes that are various sizes of the rectangle. A rectangle shape was used for the base and the main body structure of the bag. The upper and lower parts of the bag had a wavy shaped pattern. The bags have rounded corners and one of the small size bags incorporated a semicircular shape in its design. The large size handbag known as the *Samosa* bag had 2 shape options. The bag design incorporates a removable inner pocket that is attached to the sides of the bag. When the pocket was tightly

attached, it pulls the upper sides of the bag towards each other. This forms a triangular shape from the tip of the handles to the base. The bag body structure resembles a trapezoid shape as illustrated by the arrows (see Figures 4.4).

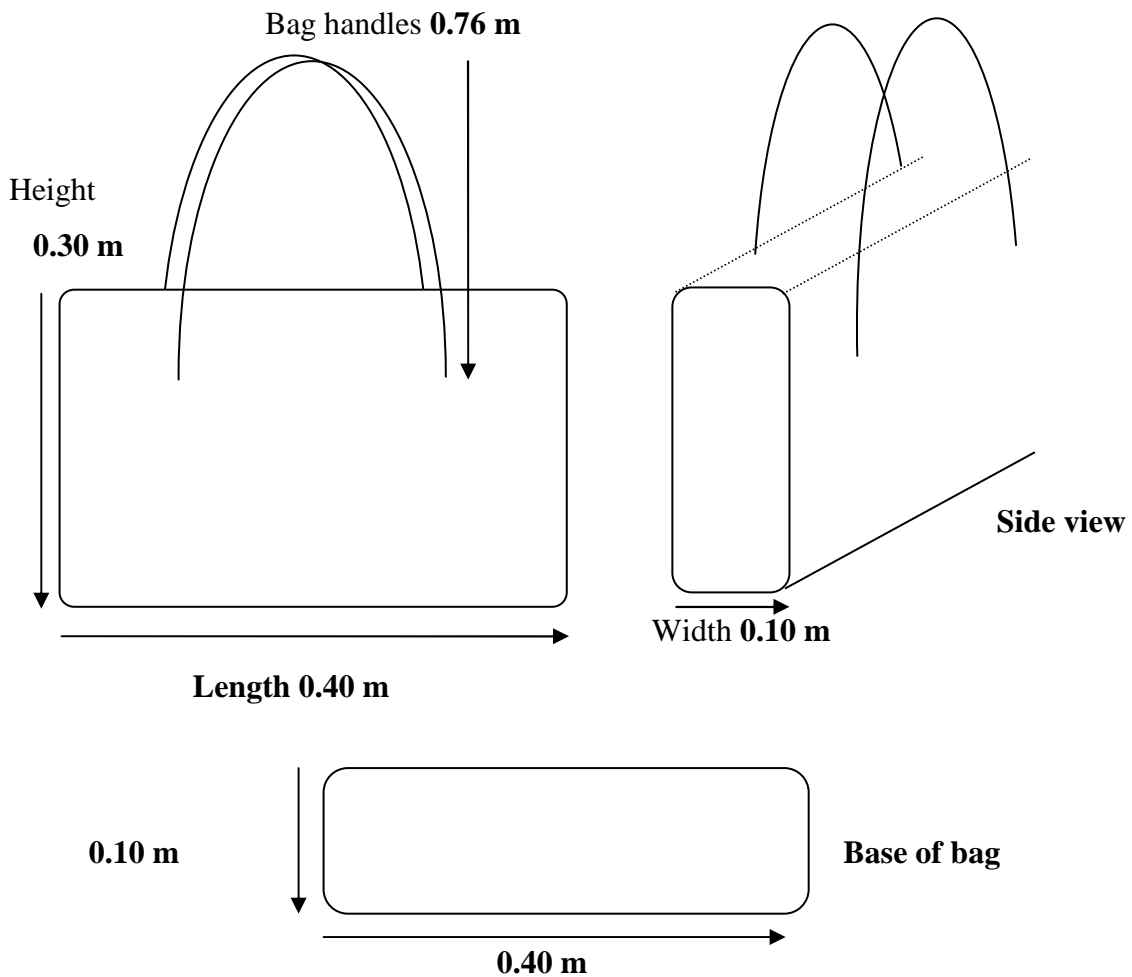

Figure 4.3: Simplified sketches of large handbag from Sanabora.

Source: Kamuiru, 2014



Figure 4.4: Large handbag from Sanabora showing shaping options.

Source: Kamuiru, 2014.

The medium, small and extra small bags in the handbag range have the similar rectangular shapes. The design of the medium and small size bags in this range includes a flap and an adjustable single strap. The two bag sizes were referred to as *Makena* bags. The extra small size bag is designed from three rectangles that are joined to form a larger rectangle (see Figure 4.6).

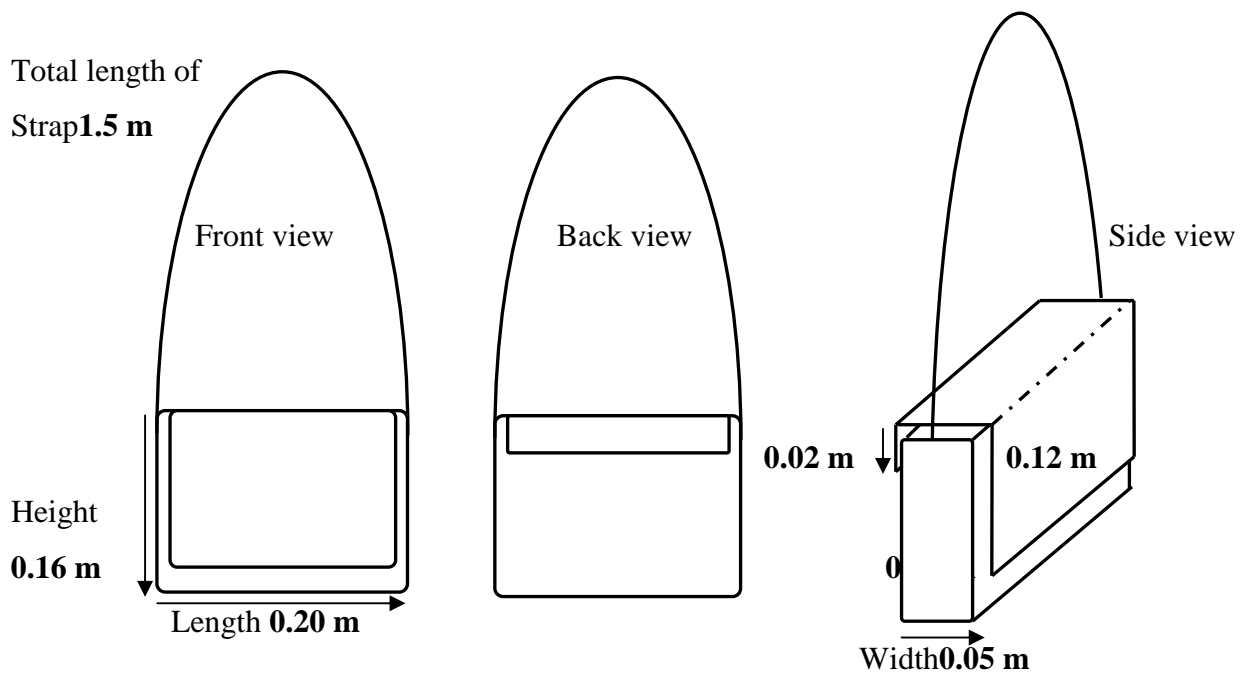

Figure 4.5: Simple sketch of Makena medium size bag from Sanabora.

Source: Kamuiru, 2014

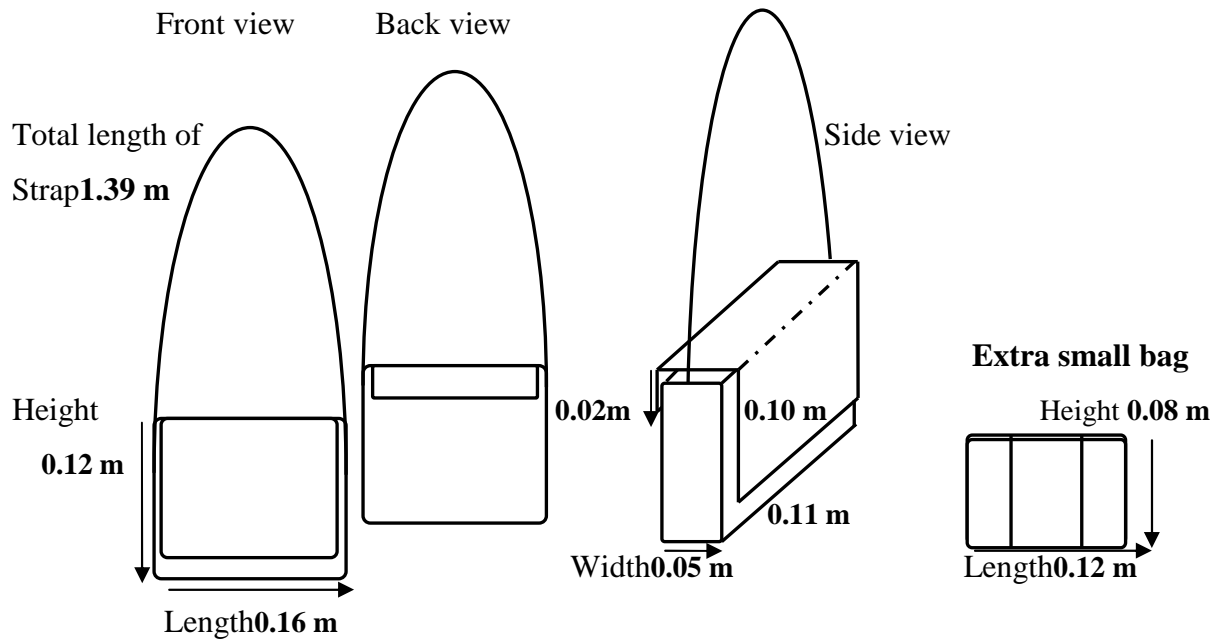

Figure 4.6: Simple sketches of Makena small and extra small bags from Sanabora.

Source: Kamuiru, 2014.

Bahati Weavers Co-operative

The Kiondo has a basic cylindrical shape. The base of the sisal baskets is circular and as the weaving continued, the same circular shape was enhanced in height. This formed the shape of the kiondos body that followed an even cylindrical shape from the base.

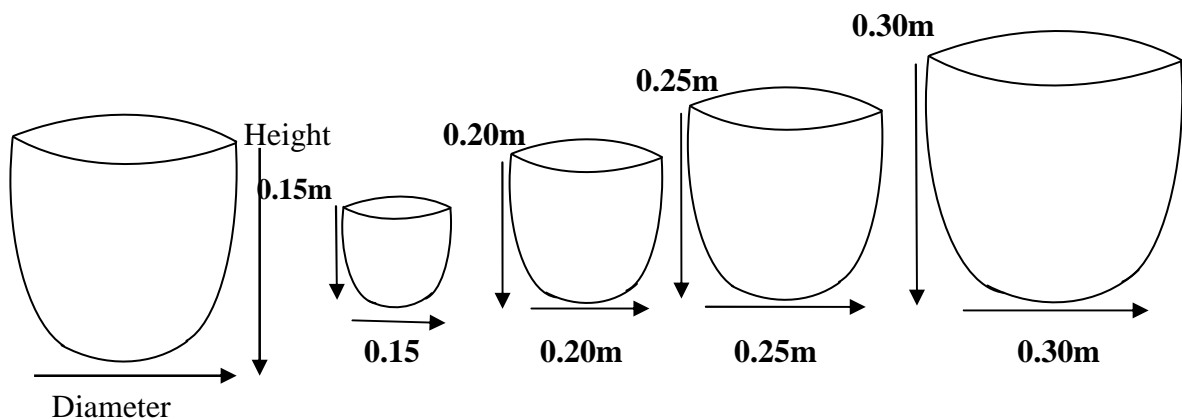

Figure 4.7: Simplified sketches of kiondo shapes and sizes from Bahati weavers

Source: Kamuiru, 2014.

The kiondo observed had its shape that was slightly altered when its finishing was done. A leather binding that included a lining and zipper that run across the kiondos diameter were stitched onto the kiondo. This gives the kiondo a means of closure that is similar to a ladies handbag. The cylindrical shape was thus altered towards the top when the zipper is closed forming a trapezoid-like shape (see Figures 4.8 and 4.9). One of the customers Teresia, who was buying a kiondo for a wedding gift, expressed that the shapes and colors had hardly changed over the years.

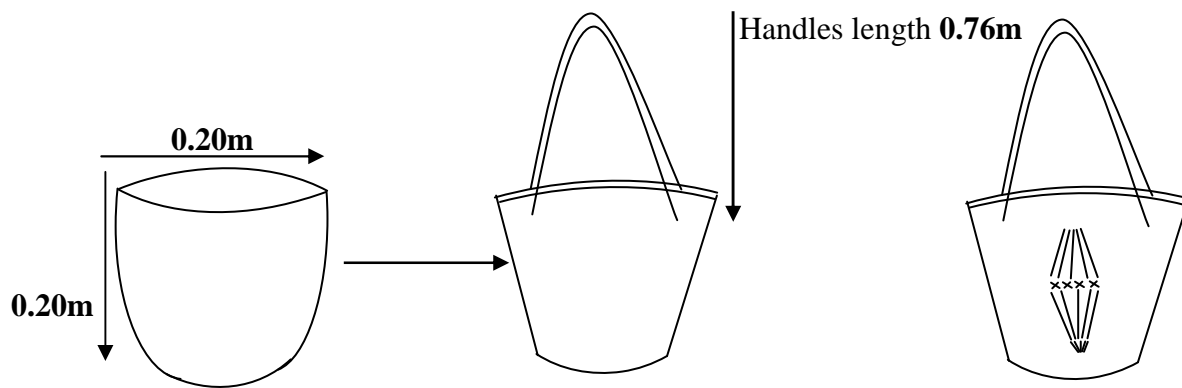

Figure 4.8: Simplified sketches of medium size kiondo altered shape from Bahati weavers.

Source: Kamuiru, 2014.

4.2.2 Bag sizes

Bombolulu Leather workshop

The large travelling bag dimensions were: height 0.4 metres, length 0.54 metres and width 0.25 metres. Length of the shoulder straps/handles measured 0.54 metres. The medium size bag was measured as: height 0.35 metres, length 0.54 metres and width 0.12 metres while the small travelling bag measured ;height 0.3 metres, length 0.3 metres and width 0.10 metres (see Figure 4.1). The sizes of the large ladies handbag measured 0.36 metres in height, 0.10 metres in length and 0.10 metres in width. The smaller size handbag was 0.25 metres in height, 0.35 meters in length and 0.12 metres in width. The handles for bags both measured 0.54 metres in length and 0.02 meters in circumference (see Figure 4.2).

Sanabora Design House

The range of ladies leather bags observed had various measurements according to their sizes. The large *Samosa* handbag measured 0.40 metres in length, 0.3 metres in height and was 0.10 metres wide. The bag two handles that measured 0.76 metres in length and 0.05 metres in circumference (see Figure 4.3). The medium size *Makena* bag measured 0.20 metres in length, 0.15 metres in height and 0.05 metres wide. The bags adjustable strap measured 1.5 meters long. The flap on the bag had a length of 0.17 metres and 0.20 metres in height (see Figure 4.5). The small size *Makena* bag measured 0.16 meters in length, 0.12 meters in height and 0.05 meters in width. The bags had a strap with a total length of 1.39 metres. The extra small bag of this range measured 5 inches wide and 3.5 inches in height (see Figure 4.6).

Bahati Weavers Co-operative

The kiondo are woven in a variety of sizes. It was noted that the Kiondo sizes varied in measurements as per each basket that was measured. Most of the baskets varied in 0.01 or 0.02 metre difference. The researcher found out from the weavers that the baskets were classified into four size categories. The sizes commonly referred to are; extra large, large, medium and small. The researcher approximated the measurements in inches for each size in diameter and height. The extra large baskets measured 0.30 metres in diameter by 0.30 metres in height. Large baskets measured 0.25 metres in diameter by 0.25 metres in height. Medium baskets measured 0.20 metres in diameter by 0.20 metres in height and the small baskets measured 0.15 metres diameter by 0.15 metres in height (see Figure 4.7). The researcher selected a medium size kiondo for observation to fulfill the objectives of this research. The leather strap handles that are fixed onto the sisal bags also varied in sizes and designs. The kiondo observed had two leather handles on that measured 0.76 metres and 0.02 metres in circumference (see Figures 4.8 and 4.9).

The kiondos were observed to have variances in their measurements and were instead approximated in the range of sizes. The alteration of the kiondos round shape was observed to be a result of the finish that includes the fixing of a zipper at the top. The researcher interviewed a kiondo buyer at the market who pointed out the fact that the kiondo did not balance well.

Consumers interviewed at the market also mentioned that the zipper made the kiondos body narrow at the top reducing the storage space. The intended function of ample storage space that the weaver achieved to create was thus distorted by the finish done by another artisan. The researcher could not confirm if this was the intended design by the weaver.



Figure 4.9: Leather handles and finish of kiondos at Kariokor market.

Source: Kamuiru, 2014.

The large and extra large size kiondos had two ways that the pair of handles was fixed on them. The two methods are explained in Appendix H. Handles for the medium size kiondos observed were all hand stitched and permanently fixed. The kiondos also had varying sizes of the handles on each bag. The strap was made from 2 leather straps that were hand woven using a traditional thonging method to form a 2-dimensional shaped strap measuring 0.02 metres in circumference and 0.76 metres in length (see Figure 4.9). A similar medium size kiondo (see Figure 4.10) had woven sisal handles that were shorter and measured 0.54 metres long and 0.05 metres in circumference. The handles for these kiondos were also stitched together to form 2-dimensional tube shaped handles. The researcher observed that both ends of the handles measuring 0.02 metres long were made flat to enable them to be stitched onto the kiondo.



Figure 4.10: Different finish of handles on medium size kiondos from Bahati weavers.

Source: Kamuiru, 2014.

4.2.3 Decorations, patterns and finishes

Bombolulu Leather workshop

The four corners of the travelling bag were stitched with leather patches that were a similar color to that of the handles. The bag had 2 leather handles each measuring 0.54metres long that had a handle stitched on each side of the bag. The front side of the bag had a small rectangular piece of leather is stitched in between the ends of the handles. A brass cast logowas stitched on this piece of leather. This was the branding identity of the bag as seen in Figure 4.15. The inside of the bag was a single compartment that is lined with a printed cotton fabric and had an inner pocket measuring 0.25 metres long and 0.12 metres high. The bag had a zipper to close it from one end to the other. The ladies leather bag on the inside has a hanging inner leather pocket with a zipper that was attached one of the inner seams by a long leather cord. This bag had no lining on the inner part. The bag was closed with four press buttons that were stitched on the inside part of the top seam. It was observed that the bag had a leather flower motif attached to the bag's handle with a leather thong. This motif had the Bombolulu logo stamped on it.

Sanabora Design House

The handbags observed had various forms of patterns, decorations and finishes. For the large, medium and small sizes, a flower decoration placed on the front side of the bag. A seven petal

flower motif was sewn on top of the leather material used for the main body of the bag. The motif was cut out from a different colored leather material from the one used to make the bag. The motif had a brass spiral pendant that was anchored onto its center by a metal press button. On the large size *Samosa* bag, three flower motifs in two colors were sewn on one side of the bag. The medium and small size *Makena* bags had one motif which was sewn on the center of the flap. The extra small bag had a simple rectangular decoration in its middle that was a different color of leather, similar to the flower motif. The *Samosa* handbag had a wavy line pattern that was seen at the top and bottom parts of the bag. The pattern was created by cutting one edge of the rectangular shaped leather pieces in a wavy line. This leather piece was then stitched onto the rectangular leather piece that was the main body of the bag(see Figure 4.11).



Figure 4.11: Sanabora large handbag details of patterns and decorations

Source: Kamuiru,2014.

The bags handles sewn on the sides had the ends shaped to resemble a slim leaf motif. The inside of the bags were lined with plain fabric and include an inner pocket with a zip. A cloth label that was sewn on the lining below the zipper of the inner pocket was branded with the producers' logo (see Figure 4.4). The large, medium and small size bags each had a magnetic clasp used to close the bag. The clasps which were fixed as a pair have each piece fixed on the opposite side of

the bag. The large *Samosa* bag had the clasp fixed in the middle of the top section of the bags' opening. The *Makena* bags had one piece of the magnetic clasp fitted on the middle section of the front end of the flap. The other piece was fixed on the lower middle section of the bag where the flap part lies. The extra small coin purse had a different finish for closure. A zipper was stitched on the top part of the inner lining and was joined to the top leather part of the purse. A leather tassel made from the same leather as the purse was tied to the end of the zipper. This was used to pull the zipper and also served as a decoration (see Figure 4.11).

Bahati Weavers Co-operative

The researcher observed a variety of patterns, decorations and finishes in the kiondos woven by Bahati Co-operative weavers. The selected kiondo for observation had on basic color of sisal used when being woven. The forms of decorations observed on the kiondo include leather strips and wooden beads that are hand sewn onto the kiondos' front side. The leather strips are arranged to forming a diamond like shape. Wooden beads are strung in the leather strip and incorporated in this design. Cowrie shells are also sewn in the leather handles section that is sewn onto the kiondo as decorative pieces. Geometric patterns such as triangles were observed one of the kiondos, having being incorporated in vertical pattern in weaving (see Figure 4.12).

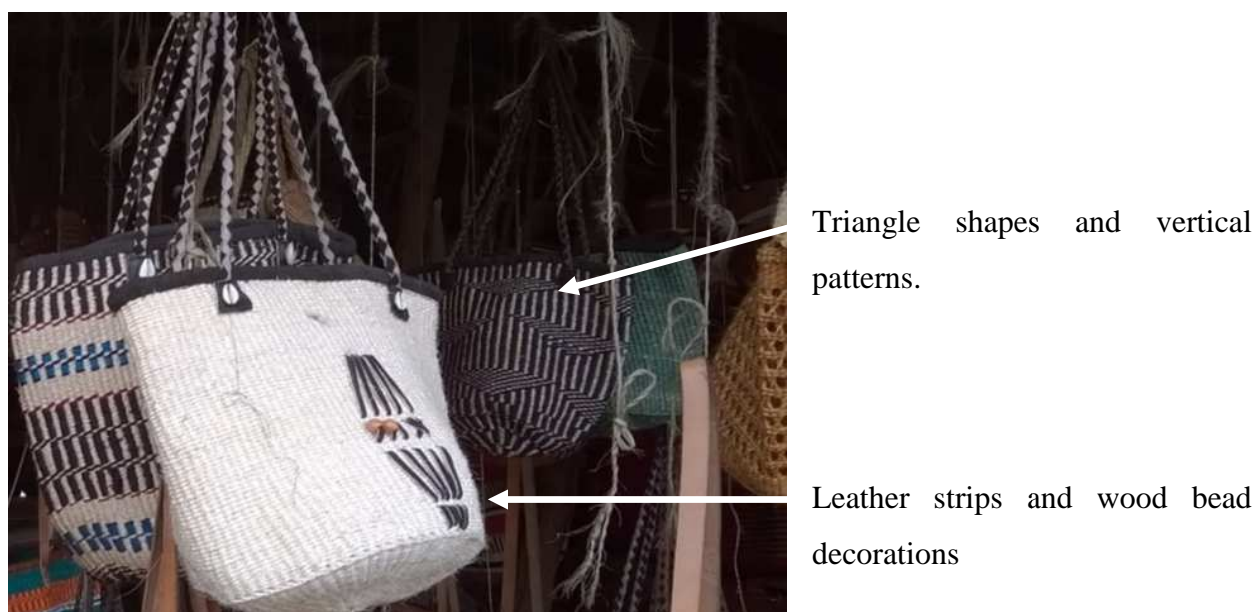

Figure 4.12: Decorations on kiondo as seen at Kariokor market.

Source: Kamuiru, 2014.

The medium size kiondo observed had a different finish on them. The kiondos had leather trimming that was stitched all around the kiondo binding the brim. The binding incorporated a zipper and a material lining that was fixed inside the kiondo. This type of finishing was machine stitched and was observed as having been applied on the medium size baskets for Bahati Co-operative weavers (see Figure 4.13).



Figure 4.13: Leather binding finish with lining and zipper on a kiondo from Bahati weavers

Source: Kamuiru,2014.

The top brim of other Kiondos that were observed had been finished in different ways. Some of the kiondos had the simple sisal binding that was folded and stitched down as the weaver finished the kiondo. Other kiondos especially the large ones were observed to have leather binding on the brim of the basket. This leather binding was hand stitched and was similar in color to the leather used to make the handles. Another type of finish observed on small kiondos was a beaded finish. Small glass beads of various colors are stitched all around over the brim of the kiondo(see appendix H).

The sisal kiondos observed at Kariokor market were woven with different colored materials that enhanced different sizes and types of band patterns. The kiondos have common patterns of two or three colored bands alternated by the main color of material used in weaving. These bands appeared to run along the basket body in a horizontal manner. Some of the sisal baskets observed at Kariokor had as many as five colored bands that formed horizontal, vertical and slanted linear patterns. The band pattern is also modified by some weavers. In one kiondo it was observed that

the band shape was elevated to form an angular line that raises the band pattern (see Figure 4.14).

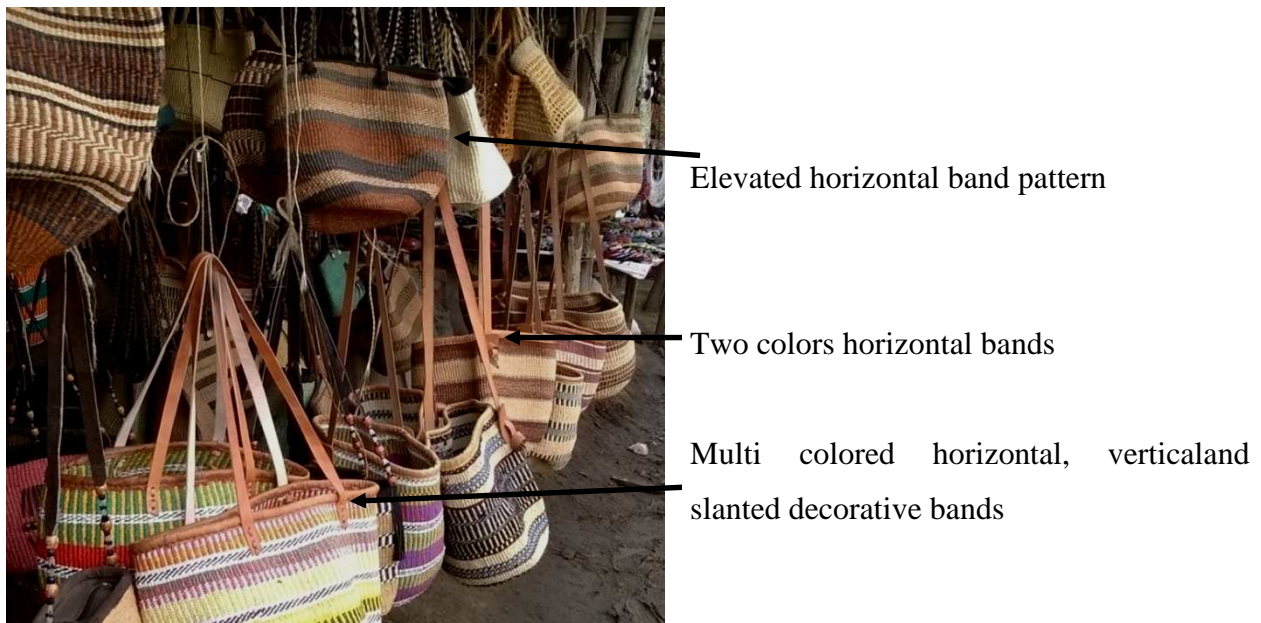

Figure 4.14: Kiondos with various decorative band patterns at the Kariokor market.

Source: Kamuiru, 2014.

4.2.4 Bag ranges and function

Bombolulu Leather workshop

The travelling bags range is in three sizes; large, medium and small. This range of travelling bags is suited for both male and female customers. The travelling bag range also includes a ladies leather handbag in two sizes. The ladies handbags are produced in sets and in the colors that match with the larger travelling bags.



Figure 4.15: Leather and canvas travelling bags from Bombolulu Workshops

Source:Kamuiru,2014.

Functions for the bags are specific to the size of the bag. The large travelling bags are suited for a long period of travel as the size of bag can accommodate a variety of outfits (See Figure 4.15). The medium size bags are suited for short term travelers such as a weeklong journey. The size of the bag can accommodate outfit changes for several days. The small size bag is best suited as an overnight bag.



Figure 4.16: The reshaping option as seen on Bombolulu travelling bags

Source: Kamuiru, 2014.

The ladies handbags were designed as an everyday bag. This bag was made in large and small sizes designed to cater for the client that prefer a small or large handbag (see Figure 4.17).



Figure 4.17: Ladies leather handbag collection from Bombolulu.

Source: Kamuiru, 2014.

Bahati Co-operative weavers

The sisal kiondos observed is woven in a range of large and medium sizes. The kiondo which is fitted with a lining and zipper serves the modern function. It has sold as a ladies handbag similarly as its secured by a zip. The kiondo is also in the size range of ladies handbags and has handles that can either be carried over the shoulder or by holding the handles and hanging it by ones side. The large size is used as a carry all as it has more space. Consumers interviewed who own this size attest to using the kiondo as an overnight bag as one is able to carry more items. One of the customers interviewed uses this bag to carry her personal effects which she would use in her day handbag and a few books and documents from the office. This way she is able to carry one bag rather than two of two. The small size kiondo is used as a day handbag by ladies who that carry a few personal effects. A variety of the medium and large size ranges of kiondos were observed by the researcher at the Kariokor market (see Figure 4.14). Bahati weavers Co-operation make large and extra large kiondos that are still used for their traditional function which was to carry an array foodstuff from the markets. The women consumers interviewed prefer these sizes of kiondos as they are very spacious, sturdy with an adjustable handle and can also be carried on their backs.

Sanabora Design House

The ladies leather handbag range observed at Sanabora includes a variety of bags and accessories. The following products were presented in this range; large size ladies *Samosa* handbag, medium size *Makena* bag, small size *Makena* bag, extra small rectangular coin purse. It was also observed that the range was further diversified to include; coin purse, ladies wallet, cheque book holder, phone case, clutch bag and a ladies belt (see Appendix K). Each of the bags in this range as the designer explained was made to be the best fit for its function. The bag range was designed for the modern day working woman who prefers to purchase a bag and its matching accessories. The large ladies handbag was made for the everyday use in a formal or informal setting. From observation it was noted to be spacious and strong. The medium and small *Makena* bags were designed for a casual look on weekends. The bags were designed for the younger generation. The extra small coin purse serves its everyday function of storage and was designed to be use with any of the bag sizes.

	Bombolulu Workshops	Sanabora Design house	Bahati Weavers Co-operative
Product Attributes			
Shape	Geometric shapes were observed. Bags had a trapezoid, rectangular or square shape. Modification of bags shape was observed.	Geometric shapes were used for the bag designs. Bags have various sizes of rectangular shapes. The large bag was observed to have shape modification.	Geometric shapes were observed. Use of circular shape for the kiondos. Modification of the round shape into a trapezoid was observed.
Sizes	The observed travelling bags sizes in Metres; Height Width Length Large 0.400.250.54 Medium 0.360.120.54	The observed handbag sizes in metres; Height Width Length Large 0.300.100.40 Medium 0.15 0.050.20	Kiondo sizes varied and a near approximation of each size in metres was observed as; Diameter Height Extra large 0.300.30

	<p>Small 0.300.100.27</p> <p>Lengths of handles were 0.54 metres and 0.02 metres circumference</p> <p>Ladies handbag sizes in metres</p> <p>Height Width Length</p> <p>Medium 0.350.120.35</p> <p>Small 0.250.120.35</p> <p>Length of handles was 0.54 long and 0.02 metres circumference</p>	<p>Small 0.12 0.050.16</p> <p>Height Length</p> <p>Extra small 0.080.12</p> <p>Lengths of handles for large bag size were 0.76 and 0.01 metres wide</p> <p>Lengths of single strap for medium bag size were 1.5 metres and 0.02 metres wide</p> <p>Lengths of single strap for small bag size were 1.39 m and 0.02 metres wide</p>	<p>Large 0.250.25</p> <p>Medium 0.200.20</p> <p>Small 0.150.15</p> <p>Observed length of handles on kiondo was 0.76 metres and 0.02 m circumference</p>
<p>Patterns</p>	<p>The travelling bags had decorative leather patches that were sewn on the outer corners of the bag. A leather patch with the company logo was sewn on the travelling bags. The ladies handbag had branded leather piece tied onto the handle on the front side of the bag</p>	<p>The ladies handbag had a wavy line pattern and a flower motif made from different colored leather pieces. The extra small handbag had a mix of leather colors used to create 3 rectangles pattern.</p> <p>A spiral brass decoration was fixed with a metal press button at the center of the motif. This decoration was observed on the front</p>	<p>The kiondo had a simple twill weave pattern that was observed in its single color sisal weave.</p> <p>It was observed that the kiondo had leather strips that were arranged to form a diamond shape. These were sewn on the front part and wooden beads were</p>
<p>Decorations</p>	<p>Decorations include the bone beads on the travelling bags.</p>		

<p>Finishes</p>	<p>The finishing for the travel bags included a zipper that was stitched on a screen printed lining that had an inner pocket. The ladies handbag included press button attached to top middle section of the handbag for closing the bag .</p>	<p>side of the large, medium and small handbags.</p> <p>The bags were all finished with a fabric lining on the inside. This included an inner pocket and the producers label with the company’s logo on it. Metallic press buttons were used to close the bags.</p>	<p>strung in the leather strips as decorations.</p> <p>For the finish, the woven leather straps were hand stitched onto the sides of the kiondo. A leather trim of a similar color was stitched on the kiondos brim. It included a fabric lining with a zipper and inner pocket was stitched onto the kiondo.</p>
<p>Range& Function</p>	<p>Travelling bags were available in a range of sizes. The sizes were in a range of large, medium and small. These bags were designed for both male and female users. The ladies handbags in this travelling range were in a large and small size.</p> <p>The bags had specific functions as per their sizes. Large and medium bags were designed for long and short term travel respectively. The small bags were designed for everyday use.</p>	<p>The ladies handbags were available in a range of sizes. A Further diversification of this range was also available. The observed bags include large, medium, small and extra small sizes.</p> <p>Each bag size was best fit for a specific function. The largehandbag is for daily use, the medium and small size bags for a casual look for younger women and the coin purse can be used by all.</p>	<p>The medium size kiondos are available in a range of colors and finish.</p> <p>The medium size kiondo that was observed is used as everyday ladies handbag.</p>

Table 4.1: Summary of Product attributes.

Source: Kamuiru, 2014.

4.3 Materials and Tools

4.3.1 Materials

Bombolulu Leather workshop

Bombolulu leather bags often have one color of leather that is complimented by a different colour of leather on the handles and decorations. The bag observed have one pocket, a main compartment and a simple zip closure. The bags are made with colored leather that has a smooth or an evenly textured finish on its surface. The leather used the handles is plain and suitable for decorations that are applied with hand held texturing tools. From observation the researcher noticed that the main body of the leather bags is often one color and is cut from a single piece of leather that is continuous. The leather bags incorporate other materials in its design such as canvas and printed cotton for the inner lining. This is done to reduce on the amount of leather that would be needed to larger sizes of travelling bags.

From the researcher's observation in the product catalogues, leather was Bombolulu's material of choice for in the making of durable bags. During the interviews the leather designer and artisans, they concur on the fact that leather is a tough and sturdy material that withstands wear and tear over a period of time. Leather made from cow, sheep and camel skins was bought in an array of colors such as black, white, blue, green, red and yellow and orange (see Figure 4.18). The leather is usually finished from the factory with a variety of textures that one can choose from.

Other materials such as canvas fabric were being used in combination with leather for the main body of the bag. Bombolulu bags that were initially made wholly out of leather are currently made of leather and canvas. The designer explained that he parts of the bag that are constantly in use (thus exposed to the most wear and tear) were designed out of leather. These specific parts of the bag include the handles, shoulder straps, bottom of the bag, corners of the bag and the top section of the bag closure. Materials such as printed cotton fabric, threads adhesives, leather boards, zippers, and base stands were also observed in used in production of the travelling bag design.

From the focus group discussions, designers conclusively agreed that the colored leather used for production is guided the current trends. Bag designers Olive and Kerry concurrently agreed that some leather colors were termed as basic colors that are timeless. Despite the changes in trend, colors such as black and brown are prominent colors that cut across every trend.

From information gathered during interviews with customers, various criteria were mentioned as used identify the quality of bags. Customers interviewed who either were buying or owned a leather bag from Bombolulu considered the material used as a key factor. One of the customers Beth identifies the quality of the bag from the choice of leather material used to make it. She explained that from her previous experience a leather bag lasts longer with constant use. She added that the other aspects she considered when buying a bag were color, size and the inner finish of the bag. Karimi explained that she also looked at the stitching of the bag and all the materials used to make it.

Bahati Weavers Co-operative

The Kiondo weavers were observed and the main material used for weaving was sisal. The sisal used is in form of various sizes of twisted strings that are available in various lengths. The strands are two thin twines that are twisted together to form a long strand. The sisal twine is bought in a roll that has a long piece of twine that measured in weight. Alternative sisal for use in weaving was usually sold in long strands that were tied together in a bunch of various lengths. They approximated between 1.14 to 1.15 metres long. The sisal strings are mainly bought by the weavers in its natural color which off white. The sisal is then dyed by the weavers according to their color preferences of the kiondo to be woven. At the Kariokor market, the sisal strings are however available in an array of colours and lengths. Observed colours of sisal include red, yellow, orange, green, brown, grey and black hues. The raw sisal twine that has not been twisted was also available at the market. The salesperson explained that some weavers opted to twist the twine themselves so they could get the sizes and lengths that may not be available at the market. The weavers at Bahati usually use the sisal that is already twisted for use (See Figures 4.19 and 4.20). The sisal fibers available in the local markets in Machakos have no standard measurements that can used to identify sizes, lengths and color assortments. Customers interviewed buying

kiondos explained that their choices were limited to what was available at the market. Mary a customer who owns a medium size sisal kiondo similar to the one observed in this case study explains that although the material is sturdy, it has a major disadvantage. The sisal kiondo she uses as a handbag over her shoulder was rubbing against her clothes causing damage. She argues that the material is rough and the kiondo was not appropriate for use as a handbag. However there was some material variation seen in the kiondos woven by weavers from different regions. She explains that wool and nylon yarns are incorporated with sisal fibers to make kiondos. Her preference for the wool kiondo is that it does not rub against ones clothes when carried and can be washed when it gets dirty. She argued that this was a good innovation in material combination.

The other materials used for finishing the bags include; the leather used for binding the bag and for making the straps, nylon lining material, metal zippers, wooden beads and Cowrie shells. For the observed bag, black suede leather is used for the binding that is seen on the kiondos top brim and has a zipper stitched on it. A black nylon material was used to make the inside pocket and lining for the kiondo. The same leather is used in thonging to make the bags handles. Pieces of this leather are also incorporated to secure the handles onto the kiondo. The wooden beads and Cowrie shells are used to decorate the kiondo. The leather used to finish the Kiondos from Bahati weavers is selected on basis of what is available to the artisan at the Kariokor market. The kiondo weavers did not select nor specify the leather to be used to finish the kiondos.

Sanabora Design House

A variety of materials were observed to be used for the production of bags. The main material used for the bags was leather available in a variety of colors and textures. The wide selection of colors and textures enables the creation of unique and vibrant range of bags. The leathers used include cow, sheep, goat and fish skins that have been processed from the local tanneries (see AppendixK). The designer explains that they are also using vegetable tanned leather to make bags. From observation of the leather bags made at Sanabora design house, the outer part of the bag is predominantly made of leather. The bags observed were made from leather which had a textured finish. The materials used on the decorative parts on the bags were leather, brass wire

pendants and metal press buttons. The other materials used in the bags include plain cotton fabric for the lining, zippers, buckles and metal feet. During production the artisans were observed using adhesive, threads, Manila paper, and leather boards. Some of the bag designs also incorporate various African fabrics such as the Maasai shuka, Kitenge, Ankara and Khanga which are matched with suitable leather. The leather accessories used for the finishes of the bag include metal hooks and eyelets in a variety of sizes.

4.3.2 Material Sources

Bombolulu Leather workshop

The leather used at Bombolulu workshop is locally acquired from tanneries in Kenya. The leather is locally acquired hides and skins from livestock farmers that is treated and added value at the tanneries. There are various qualities of leather that is sought both locally and internationally as a raw material. Ondoro, Bombolulu's purchasing manager explained that they buy Leather from Bata Company in Limuru, Kenya and at Alpha Rama in Athi River on the outskirts of Kenya's capital city Nairobi. The quality of leather dictates the price of the leather. Export quality leather is of the first grade and is the most expensive. The leather is however available to local buyers who may be interested and can afford to buy it. Bombolulu buys leather that is of the second and third grade quality. The Purchasing manager further explained the main reason to these choices is due to the affordable price and the leather is of a good quality. The leather is available in several colors and textures and factory finishes. The approximate units bought in a quarter for the past three years have been 16,000 square feet of assorted leather materials. Mr. Ondoro emphasised that these volumes of leather materials acquired are relative to the customer's orders and differ in the grade of quality. In an interview Njenga of KIRDI (Kenya Industrial Research and Development Institute) reported that the change in trends and technology enabled leather to be finished to an assortment of colors and textures. The value addition has made the leather expensive. He explained that the high demand for leather locally and for export to manufacture other goods had also contributed to the high prices. Handicraft designers in the group discussion agreed that this would mean that a bag made wholly out of leather translates into a highly priced item.

The wholesale price range of leather is between Kshs 90 to Kshs 260 per metre. The leather is available in several colors and textures and factory finishes. Bombolulu leather workshops largely use finished leather from camels, cows and sheep to make products. During the interview, Mr. Ondoro mentioned the alternative sources of leather as Sagana leather tannery and Leather industries in Thika. Bombolulu previously source form them but stopped as the sources proved to be unreliable in delivery and had inconsistencies in the quality of leather. Orders were sometimes never processed despite frequent follow-ups with the tanneries. No explanations on the delays were ever made thus the company opted to look for other reliable sources of leather.



Figure 4.18: Coloured leather swatches collection from Bombolulu workshops.

Source: Kamuiru, 2014

From the interview, Mr. Ondoro confirms that the canvas material is processed locally in Kenya by TSS Spinning and weaving company. This material has of a lower price than that of leather. The canvas used in the Bombolulu workshop alongside the leather is of a specific gauge and thickness. The canvas is CC450 which is a medium thickness that is suitable for use in making bags as it is hardy and combines well with leather. The canvas material is sold at a wholesale price of Kshs 900 per metre. The cotton materials used for lining are procured from Tanzania as plain fabrics. The price ranges from Kshs 400 to Kshs 1, 200 per metre depending on the quality of the cotton fabric. The workshop has the fabric screen printed in an affiliate workshop to adding

value to the fabric. Accessories used in bag finishing such as zippers and press buttons are bought from the local shops in Mombasa. The bone beads used in travel bags are made in an affiliate workshop by jewelry artisans.

The researchers' observation of the Bombolulu travelling bags indicated the use of other materials incorporated with the leather. The large and medium size bags were primarily made of canvas and leather materials. The leather designer explained that use of a material of a lesser cost value reduced the price of the bag thus making it marketable. He further explained that customers request for leather bags that have a specific price range and even suggest that other materials be incorporated to meet their target price.

Sanabora Design House

The leather materials are sourced from the local tanneries in Kenya. The production manager Ann explains that a variety of leather usually is bought from Alpha Rama in Athi River and Bata factory in Limuru. The Design house usually purchases leather in square feet in dozens as per the required quantities for the specific order to be produced. The purchases are often done quarterly and may vary in quantities as per the orders at hand. The purchasing manager explained that with regular orders at hand, each quarter an approximate 15,000 metres of leather material is purchased. Leather material is selected at the tanneries and the quality of material purchased is often guided by the intended function of the bag. When re-orders for specific bags are made, the design house usually requests the tannery where they had sourced the material to reproduce for them the exact material. The design house will give a sample leather swatch to facilitate the reproduction. Sanabora leather bags are made from the highest grade quality available from the Tanneries. The range of leather prices per metre are between Kshs 250 to Kshs 325. An alternative source of leather for Sanabora design house is based in Narok. The source sells vegetable tanned leather that is used for a specific range of bags. The leather used for making bags was observed to be of various textures and colours as per each bag design (see Appendix K).

The other materials such as cotton fabric used for lining, manila papers, leather boards, zippers, metal feet, clasps, hooks, eyelets, buckles, adhesives, and threads are bought in various shops in

Nairobi. Alternative sources for hand cast metal accessories like buckles are available but not reliable. Ann explains that an artisan based in Kibera supplies the design house with brass cast buckles. However the supply is not reliable on a regular basis as the demand for the handmade accessories is higher. The design house is able to get a variety of West Africans fabrics that are sold by suppliers who have shops in Nairobi. The price range for these is between Kshs 1,500 to Kshs 3,500 per metre.

Sanabora designer explained that customers often will request for a quality bag that is not necessarily made of leather material. Designers Wamuo, Nzisa, Musyoki and Minna who were interviewed on November 28th 2013, mentioned that current bag trends are also incorporating ethnic fabrics as part of leather bag designs. They pointed out the use of the coloured leather in the various bags observed and agreed that it complemented the printed fabric and lining materials used.

Bahati Weavers Co-operative

Sisal twine material is bought from the local market that is held weekly at the Katangi shopping center. Members of Bahati Weavers Co-operative also source the sisal twine from other markets in Machakos town. The group members usually buy the sisal twine in its natural colour. When the weavers need to make any kiondos in a specific colour as specified by a client, the natural twine is dyed in the required colour and distributed among the members. Other members of Bahati opt to source for the sisal twine that is available in various colours at the market. The weft strings are sold tied in bunches that contains approximately 30 strands in a small bunch or 100 strands per big bunch. A small bunch is sold for Kshs 30 while the large bunch sold for Kshs 70. These were available in different sizes that were approximated as small, medium and large sizes (see Figure 4.20). The weft strands were sold in their natural colour and the lengths approximated to 60 inches. The sisal strands used as warps for kiondos are also available in different varieties of colours that have been hand twisted into a long strand measuring an approximation of 30 meters per each wrapped piece. Some of the warp had shorter lengths and the sales lady explained that the lengths depended on the individual who had hand twisted the twine and supplied them for sale. There was no standard length for this sisal twine warp

strings. The warp threads observed at the market were sold for a price of Kshs 20 for plain colour string and Kshs 30 for the coloured string (see Figure 4.19).



Figure 4.19: Natural sisal (wefts) and coloured sisal (warps) string for sale at the local market.

Source: Kamuiru, 2014

The weavers explained that the large twisted strands were sold as the weft strands. They are used in weaving the medium and large sizes of the Kiondo. The medium and smaller size twisted strands were sold as wefts for the medium and smaller sizes of the Kiondo. The long twisted sisal string is used as the warp for weaving the kiondo. This wrap string can have an alternative material of choice such as wool or nylon string. The sales lady at the market explained that weavers from Kitui opt to use baobab fiber string while those in central Kenya use banana fiber as the wrap string. The women at Bahati weavers explain that the thinner twisted strands were also used to weave other items such as table mats and hats. Preferences are however observed among the weavers who opt for the thinner size twisted sisal strands for weaving large sizes of the Kiondo.



Figure 4.20: Natural sisal (weft strand) sizes for sale at the local market.

Source: Kamuiru, 2014.

The artisans fixing the handles, lining and decorations on the kiondos source their materials at Kariokor market. The leather material, fabric lining, zippers, wooden beads and Cowrie shells are sold by other merchants at the Kariokor market. The artisans inform the researcher that the leather is locally processed by the various leather industries in Kenya. The fabrics, zippers and beads are sourced from wholesale distributor’s shops in Nairobi. Artisan Kisilu explains that leather material used for handles and for the kiondos binding at the brim to fix the zipper costs between Kshs 70 to Kshs 200. The price may vary if any additional leather is required for additional decoration on the Kiondos body.

Materials	Sources	Prices
Bombolulu Leather Workshop	<p>Leather: Bata Factory- Limuru, Alpha Rama- Athi River, Sagana and Thika Tanneries</p> <p>Canvas: TSS Mombasa</p> <p>Fabric: Tanzania</p> <p>Other Accessories: Local sources Mombasa</p>	<p>Leather: Prices per metre range between Kshs 90 to Kshs 260.</p> <p>Canvas: Kshs 900 per Metre.</p> <p>Fabric: Kshs 400 to Kshs 1,200 per Metre.</p>

Sanabora Design House	<p>Leather: Bata Factory- Limuru Alpha Rama- Athi River Narok and Nairobi leather supply shops</p> <p>Fabric: Nairobishops that have regional suppliers</p> <p>OtherAccessories: local sources in Nairobi</p>	<p>Leather: Prices per metre range between Kshs 250 to Kshs 320.</p> <p>Fabric: Price range of Kshs 1,500 to Kshs 3,500.</p>
Bahati Co-operative Weavers	<p>Sisal twine:Local sources in the various markets at Machakos and Nairobi</p> <p>Leather for finishing: Local sources at Kariokor market in Nairobi.</p> <p>Fabric: Local shops in Nairobi</p> <p>Other Accessories Local sources in Nairobi</p>	<p>Sisal twine: Price range of Kshs 20 to Kshs 70</p> <p>Leather for finishing: Price range of Kshs 70 to Kshs 200</p> <p>Fabric: Price range of Kshs 60 to Kshs 200</p>

Table 4.2: Summary of information on materials, sources and prices.

Source: Kamuiru,2014.

4.3.3 Tools and Machinery

Bombolulu Leather workshop

The leather workshop uses a variety of tools to actualize the raw material into practical products. They include heavy duty stitching machines, cuttingmachines, punching and embossing machine(see Figure 4.22). Others are hand held tools such as needlestape measures, scribes, rulers, pliers, scissors, pincers, stamps, leather cutting knivesand skiving tools were used in the workshop (see Figure 4.21). Mr. Ondoro explains that most of the machines were imported from Germany and Italy several years ago. The handheld tools and some of the recently acquired heavy duty sewing machines observed in the workshop were locally sourced. The suppliers of

these machines have are knowledgeable local technicians who service and repair them. These technicians also trained the artisans at the workshop on the use of the new machines. Spare parts are locally available in case of the machine breakdown.

There are also newer models of machines that are available for purchase to upgrade the older ones on given financial availability. Mustapha and John, the Leather workshops designer and production supervisor respectively have vast knowledge on the machinery in use. The artisans too have used the machines for a long period and thus acquired experience that they are able to troubleshoot when a machine breaks done. They are also able to pinpoint on which machines are able to stitch very thick leather with ease.



Figure 4.21: Handheld leather tools observed at Bombolulu workshop.

Source: Kamuiru,2014.

The training of artisans on tools and machine use was offered to the artisans in the various leather training schools that the artisans attended. John explained that at Variety Village Thika which is a technical institution run by the Salvation Army, training was offered at a very basic level on leather tools and machinery. With the constant use of the machinery and tools one is able to become an expert user. John mentions that machines have also changed with time as per

new technology. During his training period in the 1980's, a lot of the sewing, decorative and leather cutting machines were operated by hand. Today the machines in current use are powered by electricity. The machines however still require human input to function. The leather workshop has an electric powered cutting/ stamping machine that is able to cut specific shapes and emboss patterns on plain leather. The cutting of the shapes is done by using steel blades that are forged into specific shaped blades act as template cutters that ensure that the leather pieces cut are identical pieces. These blades are fabricated here in Kenya at the local metal industries. The workshops provide the industries with specifications of the required tools which are in-turn made for them at a fee. The artisans however still incorporate handheld tools such as punches, leather cutting knives, Scissors, hammers and leather stamping letters in the day to day production.

Artisans have to get the initial training on how the new machine works so as to perfect handwork. Each time the workshop acquired a new machine, basic training is done by the suppliers of the machine and artisans are imparted with basic knowledge. With time and longer exposure to using the machine the artisan is able to familiarise and properly execute their skills.



Figure 4.22: Leather stitching machines observed at Bombolulu Workshop.

Source:Kamuiru, 2014.

SanaBora Design House

The artisans were observed using a variety of tools and machinery at their workshop in Ngara. Basic handheld tools such as scissors, Stanley blades, and knives were used for cutting the various materials used. Different types of rulers were used to create shapes and patterns on templates during the designing stage. To take measurements, the artisans used tape measures and rulers. Markings on fabric and leather were made with tailors chalk and pencils. Other handheld tools used include hammers, scribes, pliers and small brushes used for glue application, needles to stitch decorations on the bags. The handheld tools were sourced in various Nairobi shops. A variety of machines of heavy duty sewing machines, skiving machines, walking foot machine were also observed (see Figure 4.23). The head designer Beatrice explained that the industrial machines used in the workshop have all been sourced from local supplier who imports from Germany. She undertakes research on which machine is needed for a particular process and informs the supplier on the specifications. The supplier checks if he has the machine and if not, imports the machine for the Design house to purchase it. The servicing of the machines is done by the technicians provided by the supplier. In the group discussions, the procurement of appropriate tools and machinery was emphasized as a factor that contributes to the quality. Designers Wamuo, Nzisa, Bee and Minna involved in the handicraft sector were in agreement that finance ability of the case studies determined their access to appropriate tools, machinery and raw materials.



Figure 4.23: Artisans observed working at Sanabora design house.

Source: Kamuiru, 2014.

Bahati Weavers Co-operative

The actual kiondo weaving requires almost no tools or machinery. The hand done skill was executed by weaving sisal wraps and wefts to form the kiondos body. The tools observed in use by the Bahati Weavers was a pair of scissors that was used to cut the sisal twine and a large size needle used to stitch down the final weave at the top of the kiondo. The kiondos that are finished by the weavers are those with the sisal handles. This was observed at the workstation as the hand stitching was done by the weavers (see Figure 4.24).



Figure 4.24: Members of Bahati weavers observed working on kiondo finishing.

Source: Kamuiru, 2014

The leather and lining finishing of the kiondo was usually done at the Kariokor market. Artisan Kiswilu who is stationed at the Kariokor market stalls specializes in machine stitching, fixing of linings and handles on kiondos and other baskets types. The leather handles are all pre cut pieces of leather that measure 31 inches long and 1 1/2 inches wide. The leather handles observed below were made by overlapping the leather piece over a cord that was hand-stitched to form a cord. Both ends of this cord had a 1 inch allowance that was left flat. This flat end was then hand stitched onto the kiondos body with a needle and nylon thread. The handles measure 30 inches long and 1 inch circumference when fixed onto the kiondo.

To fix the lining that has an inner pocket, he uses a sewing machine to stitch the lining and zipper into the kiondo (see Figure 4.25). The researcher observed the artisan using the kiondo to measure the length of lining material required. Using a pair of scissors, he then cut the required pieces for an inner pocket, the bottom and sides of the kiondo. The pieces were stitched by joining the inner pocket pieces to the side and bottom piece to make one complete piece of lining. The complete lining was then stitched onto the kiondo using a sewing machine. At no one time is the artisan observed using a tape measure while working.



Figure 4.25: Artisan observed fixing the lining in a kiondo at the Kariokor market.

Source: Kamuiru, 2014

	Bombolulu Workshops	Sanabora Design house	Bahati Weavers Co-operative
<i>Categories</i>			
Materials	Bags are made from a variety of leather and canvas materials. The travelling bags have a lining with an inner	Bags are made from leather material. A plain cotton fabric was used to make the lining with	The kiondos were made from sisal material that is available in a natural off white color. The

	<p>pocket made from a printed cotton material.</p> <p>The finishing of the bag includes a zipper at the top of the bag and two leather loops at both ends. A smaller leather loop with a bone bead is stitched below the leather loops on sections on both sides of the bag.</p>	<p>an inner pocket.</p> <p>The bags decoration includes a brass wire spiral pendant that is attached to the bags surface by a metal press button.</p> <p>Other accessories include metal buckles, metal feet and magnetic clasps.</p>	<p>sisal is also available in a variety of colors. The kiondos were finished with use of leather material for binding and for the handles. A nylon fabric was used for the lining. Wooden beads and Cowrie shells were used for decoration.</p>
Sources	<p>Leather materials are sourced locally from Tanneries; Bata factory in Limuru, Alpha Rama in Athi River and Sagana.</p> <p>The zippers used were bought from local shops in Mombasa town. The cotton fabric used for the lining of the bags was bought in Tanzania and screen printed at the workshop before use.</p> <p>Bone beads are made by jewelry artisans at the Bombolulu workshop.</p> <p>The machinery and hand held tools were sourced both locally and from Germany.</p>	<p>Leather materials are sourced from Bata Factory in Limuru, Alpha Rama in Athi River and Narok.</p> <p>The leather metal accessories are sourced from Nairobi shops. Alternative source for the decorative pieces was an artisan in Kibera.</p>	<p>Sisal material is sourced from local markets and hardware shops in Machakos. Some is factory process while some are hand finished.</p> <p>The other materials used for finishing such as leather, fabric for lining wooden beads and threads are bought in wholesale shops in Nairobi.</p> <p>Hand held tools in use were sourced locally.</p>
Tools &	<p>A variety of machines were observed in use. These</p>	<p>Hand held tools that were observed in</p>	<p>The basket weavers usually use handheld</p>

<p>machinery</p>	<p>included heavy duty stitching machines, cutting, punching and embossing machines.</p> <p>Hand held tools such as tape measures, pens, pencils, ruler's pliers, scissors, pincers, stamps, brushes, leather cutting knives and skiving tools were also used in the leather workshop.</p>	<p>use include hammers, pliers, blades, scribers, pens pencils, scissors, ruler's tape measures, tailors chalk, brushes, and needles.</p> <p>Others are heavy duty sewing machines, skiving machine and a walking foot machine.</p>	<p>tools such as scissors to cut the sisal twine. A needle is used to stitch up the top weave of the kiondo and when fixing sisal handles.</p> <p>A sewing machine was used to fix the lining and zipper of the observed kiondo. The lining is measured against each kiondo.</p>
-------------------------	--	---	--

Table 4.3 : Summary of materials, tools and machinery used in the case studies.

Source: Kamuiru 2014.

4.4 Product Realisation Processes

4.4.1 Product design and development

Bombolulu Leather workshop

The design collections are compiled by leather designer Mustafa Mohammed, who has over twenty years' experience in leather work. Every year the leather workshop comes up with a new collection of bags. With the coordination of the Programmes designer, marketing team and existing client base, the various samples form the basis of an annual catalogue. Mustafa mentions that he gathers additional market information from marketing department, the critiques and inputs from the clientele and deciphers this when designing a new collection. Market and consumer trends are also part of the research Mustafa is involved in. He emphasizes that this information is key to the new design collection. The marketing manager explained that the customers who buy from the leather workshop also largely contribute to the design aspects of leather bags. Most of these designs have exclusivity agreements between the customer and

Bombolulu Leather workshop. However the information from the designs is also part of learning in the product development process.

Design process of a leather bag usual starts at the research stage. Mustapha works on finding out on the latest bag trends. This involves visits to other local leather artisans within Mombasa, local Boutique shops that stock leather goods and also gathers information from the internet. Continuous assessment on clientele feedback on bags sold from the onsite shop and those produced for wholesale also form a basis of design trends requirements. From his initial training in Malindi on leather production, a large influence on his design work was the cultures of the people who live in Mombasa. Traditional motifs and Swahili cultural items largely contributed to his design style. From the focus group discussions the designers agree that traditional designs were often worked out to the specific function of a bag. Customers Karimi and Harriet mentioned that the bags' design and was the first aspect they considered when buying a bag. They explained that their choice of bags was guided by current trends.

SanaBora Design House

Sanabora design house work as a team to conceptualize ideas for a new bag collection. The team includes the head designer and trainer Beatrice, a graphic designer, production manager and marketing executives. This team is involved in the brainstorming of ideas for the annual catalogue. Each member contributes to the product development by giving the relevant information gathered from research. The head designer over the years has also trained and imparted her design skills to them. The product design and development of bags is mainly guided by the current trends, inspirations and the customer's requirements. The production manager explained that clients also contribute to some of the design ideas for new bags and these may include modifications of an existing bag design. Preferences are given on the specific trends, shapes and colors that sell well among their retail customers. The customers also offer feedback on the bags they have previously purchased. Sanabora designs are largely influenced by the customer's requirements and the bags made are made to best serve the intended function. This in turn guides the team on the materials that are best suited to make the bags. With the market research and trend information the team comes up with designs of an appropriate bag for a specific consumer that is best fit for its function. She explains that Sanabora leather bag designs

represent a fusion of contemporary design and African concepts. As described in their current catalogue, the designed range was made of unique, vibrant and quality bags with an ethnic twist.

Bahati Weavers Co-operative

The kiondo weavers have over the years been weaving kiondos of various designs for the local markets. For any new product development, the weavers explain that any weaver usually comes up with their own designs, patterns and color combinations. The weaver will make the new kiondo to completion and present it to the group members at the next gathering. Any additions or modifications may be noted by other members and discussed among the weaver. More often the improvements are included or omitted in the making of the next kiondo as the initial one is already complete. Often they are approached by consumers to weave products for them. The requested product usually has specifications of colors, designs and size. The weavers discussed amongst themselves on the specifications and each one had to follow the specifications and weave the required kiondo. The traditional application of patterns and creativity vary in each weaver and therefore applied in the weaving of baskets individually. When a new kiondo is completed, the other weavers will keenly observe the pattern and try to replicate it by weaving a similar kiondo. To a large extent, the women acknowledge that the new kiondos they weave are influenced by the new kiondo ideas they see in the markets and those ideas requested by a customer.

4.4.2 Ideation

Bombolulu Leather workshop

Conceptualization starts with a hand drawn sketch that communicates the basics of the bag. The designer first impression of the bag is through this rough sketch. Design ideas are sketched in detail. The measurements that denote size, stitching allowances and materials to be used are also included. In the sketch seen in figure 4.26, it shows the outer structure and shape of the bag. The sketch includes the specific material to be used (in this case leather incorporating raffia décor pieces.). It roughly depicts the decorations and where they are to be placed. The sketch was proposed for an overnight medium size, hold-all travelling bag that is reasonably price. The

sketch required two shades of leather (black and brown) for the main body of the bag. The handles were proposed to be made out of leather and partially covered with raffia. The client proposed that the sides of the bags body to have triangular pieces of Raffia patched and sewn onto the leather as decorations. The design incorporates leather to be used at the four corners of the bag for sturdiness and to enhance durability.

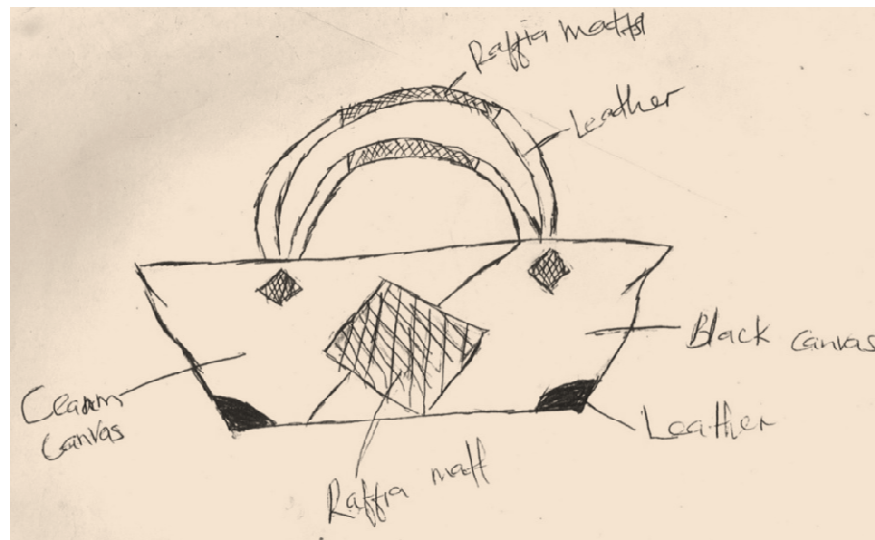

Figure 4.26: A simple design sketch of a bag from Bombolulu.

Source:Kamuiru 2014

In other instances designs are provided to the producers by a client. A sample request is send to Bombolulu with specificationsfor the bag to be made. Mustapha explains that the design and production team study the details so as to interpret the sketch accurately. Example of a detailed design sketch is Figure 4.27below.Mustapha explains that a detailed sketch of the bag includes the specific details and dimensions. The length, width and depth of the bag are specified. The color of the leather, the lining material, size and interior of the bag are all explained in detail. The number of partitions and required pockets are also drawn in detail. A client may also request for the producers guidance on other available materials that can be used as a better alternative. This is also included as a note in the detailed sketch. The client has requested the producer to adapt the bag as per the skills and the availability of materials (see Figure 4.27).

The researcher noted observed that the range of travelling bags selected for the study has a printed cotton lining and an inner pocket. The bags include a variety of fabric linings that are screen printed with various African motifs. The designer observed that the prints for the bags lining were done in a specific color that match with the outer leather and canvas material of the bag. This was one of the details to be noted during production according to the color of material used. In the product development sketch, a foot note would be include specifying that printed lining material for each the bag should be of a similar color as that of the bag.



Figure 4.27: Detailed design sketch of a bag from Bombolulu.

Source:Kamuiru 2014

SanaBora Design House

The design teams' ideas are consolidated and represented on paper. Ideas for a bag design are first presented as a simple sketch (see Figure 4.28). The general design of the bag is drawn showing the bags shape, approximate size and function. The team agrees on the details on sizes, the various bag parts, the materials to be used, finishes and decorations as intended in the final

bag. These are then added to the sketch. The sketch is then handed over to the graphic designer who uses the computer to draw the bag design in actual details. The bag sketch shows the front, back, side and inside parts of the bag. The sketch includes the materials to be used, patterns, textures, colors and decorations are incorporated in the sketch (see Figure 4.29). This gives the team a visual idea of how the actual bag will look like. The final 3 dimensional sketches will be used to guide the technical production team in making the bags' prototype.

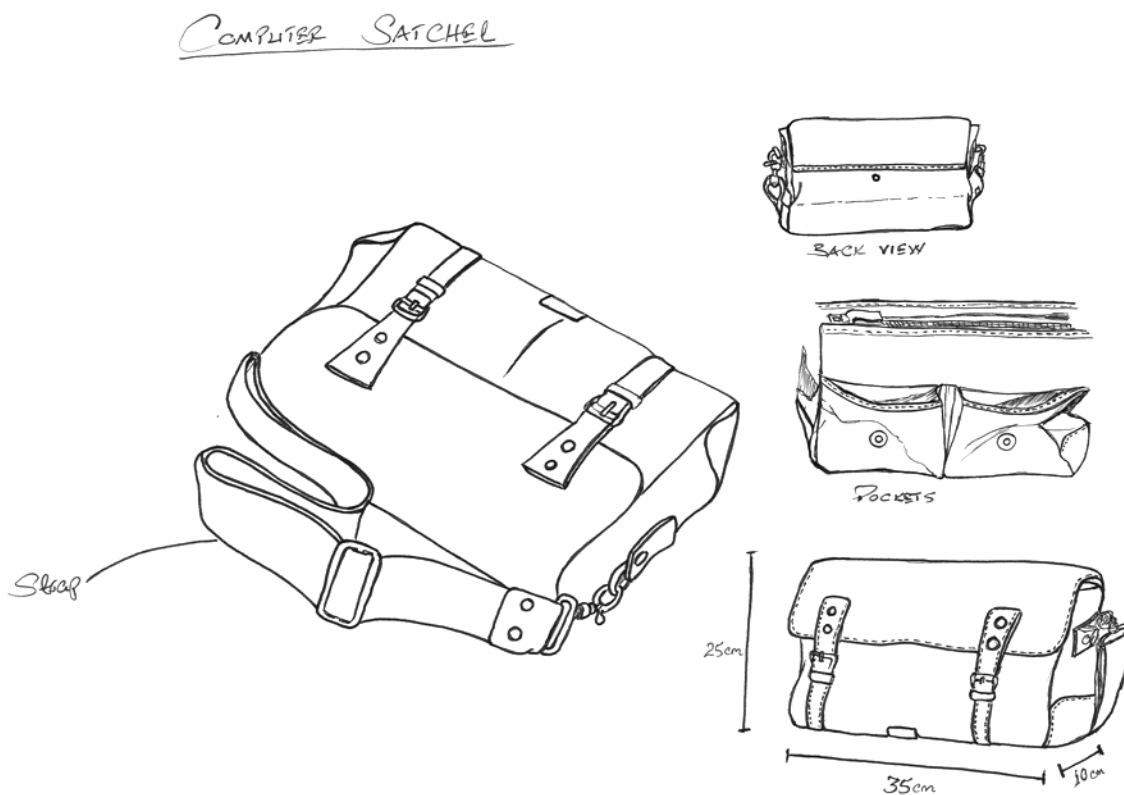

Figure 4.28: A simple design sketch of a bag from Sanabora.

Source: Sanabora Design House, 2014

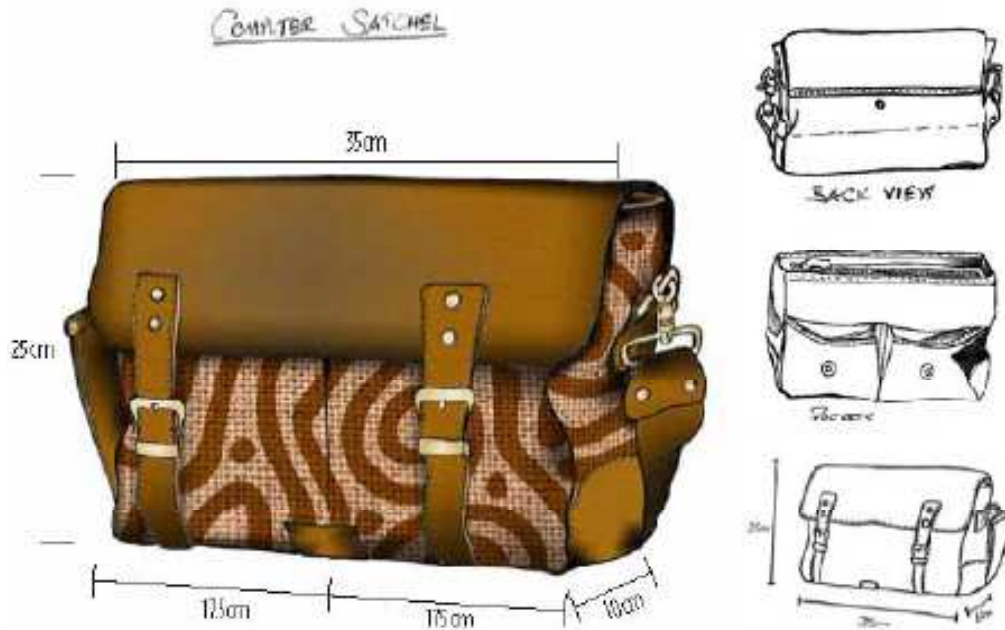

Figure 4.29: A detailed design sketch of a bag from Sanabora.

Source: Sanabora Design House, 2014

Bahati Weavers Co-operative

The kiondo weavers are all involved individually in conceptualization as each one is equipped with the basic weaving skills. The weaver thus has the basic idea of the kiondo that they want to make to completion. The Bahati Weavers Co-operative members were not observed as having any sketches of the kiondo they were making. When asked what one was working on, the weaver will explain the intended size of the kiondo and any patterns or bands of colors to be incorporated. Any design idea that a weaver had was executed and observed as their weaving continued. The weavers interviewed were able to explain in detail how many colors will be used and the number of colored bands there will be per each color. One of the weavers Ndunda, explains that a client will specify a color of choice and the size of the basket. These however are not sketched and ideation was referenced was from memory. Some clients give the weavers a sample of the colored sisal string or the actual kiondo sample to be used for reference in production.

4.4.3 Sampling

Bombolulu Leather workshop

The researcher noted that after conceptualization, the next step was the sampling stage. The leather designer next step was to make an actual sample of the bag from the details in the sketches. An actual size template or pattern is cut out of manila board and the various pieces were labeled. The first trial bag that is usually the prototype is measured out from these patterns; pieces are cut to make an actual bag. The trial bag is made from waste fabrics that are often cheaper to use as opposed to using the actual leather. Mustapha explains that this is done to save on the leather and in case of any alterations, there is no wastage incurred on the leather. Finished leather is an expensive material and it is treated with the utmost care here in the workshop so as to maximize on usage. Mustapha emphasizes that one has to be careful with using leather and the measurements have to be accurate and exact.



Figure 4.30: Template making as observed at Bombolulu.

Source:Kamuiru 2014.

Once the designer has a trial bag assembled and any necessary modifications have been rectified, the manila template is adjusted to the correct sizes. The designer will make a replica of the correct pattern in leather board, which is a more durable material for reference for bag making. With all the accurate measurements an actual leather bag can be made. Mustapha then selects from the workshops' store the appropriate piece of leather to use to make the sample. He emphasizes that good quality materials are key to the design of the bag. He then cuts out the bag pieces with the aid of the patterns (see Figure 4.30). The leather designer will then stitch

the complete leather bag and this is the prototype that is used as reference during training and actual production of bags. After completing the bag, it is then priced by the designer to get the actual cost of the bag.

Mustapha explained that the process of costing the bag as follows. The bag is broken down into each component/material used. The leather used to make the complete bag is measured and the total square feet are identified. This is calculated against the buying cost of the leather per square foot. The cost of material used for lining is calculated as per the metres used. Other components such as zippers, press buttons, leather cords, threads, glue and other accessories used depending on the bag design are also included in the material cost. The labour cost is calculated as the next step. The time taken to make the first bag and the prototype is usually averaged to get time taken as labour. The workshop adheres to the government wages regulated and this is usually the basis used for labour calculations. Material and labour give the production cost of the bag. The other factor considered is the overheads that cater for the energy used, tools and machinery and other administrative costs. A percentage is included and multiplied with the production cost to get the whole sale price of the bag. Wholesale prices are considered for an order of a dozen bags and above. A percentage is added to get the retail price that is usually the price of a single bag at the shop. Prices are reviewed annually to get the proper cost of materials and labour that may have changed. The sample bag is photographed for purposes of future reference. The Production process follows and sometimes may overlap with the new skills training of artisans for the bag production.

SanaBora Design House

The design house has employed a master craftsman Peter, who is also a member of the technical production team. Ann explains that he is all rounded and has the skills, knowledge and experience in leather bag making. He usually makes the prototype for each bag design under the supervision of the production manager. The design team gives detailed sketches that are explained to the master craftsman. The master craftsman begins the sampling process by making the design templates. The designer explains that the activity is time consuming as each part of the bag is broken into its various components and a pattern is made. This exercise requires accurate measurements of the bag pieces as per the sketch and including the stitching allowances

for the seams. The master craftsman may even work for a whole day on template making. The templates are cut out of hard paper board and are used to guide the artisan in cutting the materials to be used. The various pieces of the bag cut from leather and fabric are joined together by gluing, folding and stitching. The decorations on the leather, the lining, label, inner pockets and fixing of zippers are worked on as separate pieces. The various pieces are then joined together with the final stitching the bag structure into a complete bag.

Any technical challenges that are faced during the sample making process are pointed out to the supervisor and consultations are made to the team. The master craftsman may advise on any technical difficulties of the bags construction. He also suggests what processes may or may not be possible to achieve. The prototype of the bag is accessed by the design team. Any amendments to be made on the bags design are discussed and the changes are explained to the master craftsman to be rectified. When the prototype is satisfactory, pre-production batches of bags are made. The artisans in production make 3 to 5 bags of the prototype bag design. The designer explained that this is usually done to confirm the time taken for production and any other technicalities that other artisans may face. An average time for production is recorded from the time taken during preproduction. After that process, the bags pricing is worked out. The design team is involved in working out the initial price of the bag.

The production manager went on to explain that the variable costs are calculated. The material cost is worked out based on the amount of materials used to make the bag. The total amount of leather used is noted and cost is calculated as per the buying price, cost for the fabric used for the lining and inner pocket is also added. The accessories used like the brass pendant, zippers, magnetic clasps and feet for the bag have their costs included in the total material cost. The next step is to calculate the labour cost which includes the average time taken to produce the bag. The team works out the total of the variable costs, fixed costs and profit margins with a percentage to get the wholesale price of the bag. A further multiplication of the wholesale price gives a retail price. The production sample bags which are now complete with a selling price are photographed and can be used for test marketing. Prices of the bags are reviewed every two years to accommodate the change in material prices and consumer spending trends.

Bahati Weavers Co-operative

The researcher observed that a kiondo sample of a new design was made by any skilled weaver within the group. The weavers having understood the clients request prepared to undertake the task. The customer had provided the weavers with the required colors and sizes of the kiondo. The sisal materials required in the specific colors were bought for weaving the sample. The members discussed and agreed on specific members available to weave the samples. Materials are distributed and the weaving begins. The weaving cannot be complete only at the work station and will continue at home until the kiondo is complete. Once a kiondo is complete, the weaver takes it to the other members who confirm if it meets the specifications. This member who had been given the specifications by the customer will confirm if the sample has been done as per specifications. The kiondo it is presented to the customer who gives the approval. If production is to be done, the weavers will refer to this sample.

The researcher observed the weavers taking note of the number of rows the wraps had used to create a specific pattern on a color band. This was done by counting and constant reference was made to the sample basket. In instances where the kiondo to be woven has no reference, the weaver worked out the design and patterns in reference to similar sized kiondo. For these traditionally skilled artisans, a master sample was not made by a specific individual for purposes of replication. Each weaver developed their own patterns and color combinations. The weavers often are in agreement on the size, colour combinations and general design of basket to be made. These are the aspects that guide the prices of each kiondo. Each kiondo size had a price range for it. A plain colour of kiondo with no handles had a lower price as compared to a multicolored kiondo that had a leather handle and binding at the top brim. Each weaver when questioned individually would quote a similar price and would be willing to review the price downwards. The observed medium size kiondo that was plain colored had a price range of Kshs 200 to Kshs 250 without the lining, decoration and handles. When it was fixed with the lining, zipper and handles it retailed for Kshs 350 to Kshs 400. One of the retailers at the Kariokor market quoted to the researcher a price of Kshs 450 for the same kiondo.

4.4.4 Production process

Bombolulu Leather workshop

The first step for the production supervisor was to identify the bag prototype sample and the patterns for it. The artisans make reference to both the first trial bag and the patterns and study in detail the parts of the templates/patterns for the particular bag. From observation at Bombolulu, the training for the production of a new bag was usually done after the product development stage or before the commencement of mass production. The training of bag prototyping is overseen by the designer and it involves the artisans and the production supervisors. For training in the making the bags, Artisans use inexpensive or recycled materials to cut out the pieces of the bag and stitch a sample of the bag required to be produced. With this first prototype, the artisan is able to train on the cutting of the patterns as well as the stitching up of the bag. Corrections and imperfections can be redone be made on the same sample. Once the satisfactory training has been done, the artisans are able to cut out the correct pattern and stitch the complete bag to completion on the leather material. Production of the bag in quantities commences per the product brief. The supervisor noted the amount of leather and other materials required as per the required bag quantities. The leather material is selected and required quantities are picked from the materials store. Artisans were observed each working on a bag from the basic step of cutting the different pieces, gluing the pieces together and complete stitching of the bag. Each process is observed by the supervisor and the artisan is able to avert any mistakes in production.

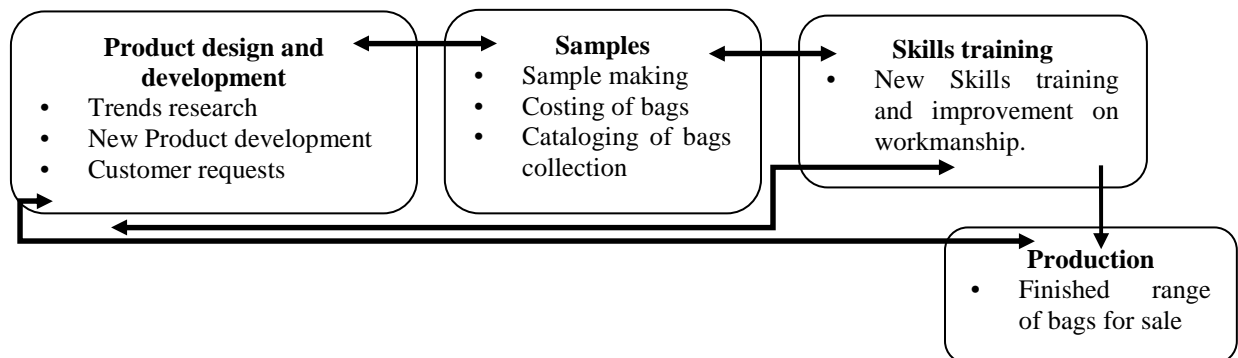

Figure 4.31: Summary of the Production process at Bombolulu Workshop.

Source: Kamuiru,2014

Sanabora Design House

The production manager explained that the team members included artisans that are excellent in pattern making, cutting and stitching different parts of the bag and a master craftsman who excels in the joining and finishing the bag structure. The artisans involved in the production of bags at Sanabora design house work as a team. The researcher observed the artisans as they worked in their workshop. The bag order at hand was worked on in two sections. Two artisans were involved in cutting out the various pieces of bags that were enough to complete the first part of the order. After several days the cutting process was completed. The pieces were glued and stitched together to make the basic bag structure. These are then passed on to another set of artisans' for the final stitching and finishing. Ann was constantly checking the ongoing process of the bag pieces. The artisans receiving the bag pieces at each stage were also observed counterchecking if the pieces were appropriate for the next process. Ann explained that when an order for large bag quantities was being worked on, additional artisans were contracted. The team players were part of the quality controllers at every process.

Each artisan is specializes in particular skill of leather production. The team works in a step by step production process that ensures the division of skills and knowledge. The basic production stages involve cutting of bag pieces, gluing and stitching, final stitching and finishing. At each of these production stages there are artisans who have the training and specialize in a particular skill. Each process is thus undertaken by the best skilled artisan ensuring that all the bag parts are well done. The production manager emphasized that with the production members working as a team, there was the assurance that every step adhered to the set standards at Sanabora. She explained that each artisan was able to work efficiently as they were involved in a particular process that they were skilled at. The finished products are counter checked for quality by the production manager and the designer. The products quality was passed as per the set criterion for the Sanabora brand that has to be adhered to. The researcher was shown the bags that failed in terms of quality. Aspects such as uneven stitching of decorative beadwork, use of wrong color of thread for stitching and inconsistent stitching were considered as faults that affected quality.

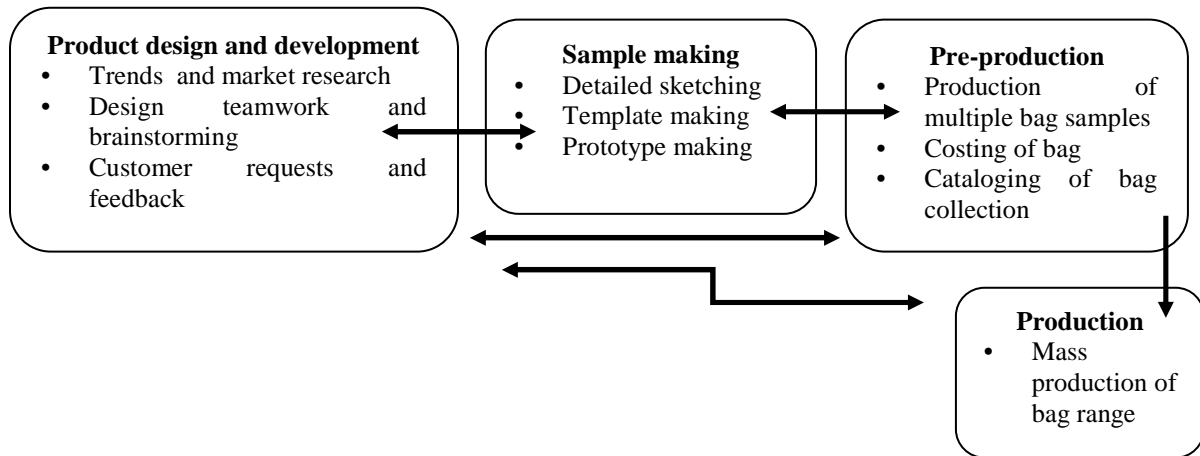

Figure 4.32: Summary of the Production process at Sanabora design house.

Source:Kamuiru,2014.

Bahati Weavers Co-operative

The weavers usually are in agreement on the kiondo design required to be made. The first step in production was to source for the sisal twine from the local market in the required colors and quantities. The sisal twines usually sold are ready for use and are bought in form of warps and wefts. A basic twining technique was used to make the basket that the researcher observed for this research. A natural color of sisal was also used throughout for this particular plain color kiondo. It was observed that the weaver began the base section of the kiondo with 3 warps threads that lie crossing each at the center to form six points. Two weft threads were twined to each of the wrap threads. In this weave the wraps thread is in between two wefts. The 6 warps were woven in a circular direction. The weaving continued until six to ten circular rows of weaving could be counted. This was the formation of the kiondos base. Additional warp threads were then added to widen the base. A sisal warp string was bent into half and placed in between two of the woven warp threads. The new warps were anchored into the weaving by use of the weft threads that interlocks them. More warps were added after a number of circular rows had been woven to create the required base diameter of the kiondo.

Once the base weaving is complete, the weaver continued with the twining technique in circular motion to form the body of the kiondo. The weaver measured the kiondos height by counting the number of rows. The kiondo weaving process is seen in the images in appendix 10. Once the required height was achieved, the top part was finished by folding the warp threads down and sewing over of the weft threads tightly onto the kiondos body (see Figure 4.24). The weaving takes several days and even weeks for some producers to finish. The amount of time taken to weave will depend on the time a weaver allocates to this activity. During the research period, it was observed that the medium size kiondo took 4 days to complete weaving.

Once the kiondo was complete, the weaver required to contact the artisan who would finish the kiondo by sewing the leather binding, lining, zipper and handles. This finishing process was observed at Kariokor market on a variety of baskets. The kiondos and the fabric to be used for the lining were given to the artisan. The artisan then selects the leather available for the binding and zipper size to be fixed onto the kiondo. It was observed that each kiondo was used to measure the size of its lining required. The artisan explains that this was because each kiondo has its own size difference. The artisan measured the base of the lining by placing the kiondo on top of the fabric. The fabric was then cut along the base of the kiondo. The height was likewise measured by placing the fabric onto the kiondos body. The length required was marked by snipping a piece of fabric that is slightly over the edge of the kiondo. The measured fabric was cut and the various pieces were stitched together. The complete lining was then machine stitched onto the inner part of the kiondo. The leather binding that included the zipper was then stitched over the kiondos brim. The process is repeated as per the kiondos that required this finish. Depending on whom the baskets were for, they were either sold at Kariokor market or returned to Bahati Co-operative for final packing and delivery to the client.

The production process of the kiondo as observed at Bahati weavers is not completed under one roof. The weavers therefore cannot supervise the finish done on the kiondo at Kariokor market as they are not present. Most of the time the kiondos once finished are sold to wholesalers in the market. Any feedback given by the customers at the point of sale is often unknown to the weavers. This aspect of a disjointed process of production was also pointed out during the focus group discussions by designers Musyoki and Wamuo, who have previously worked with kiondo

weavers in Ukambani. They explained that it became difficult to control the outcome of finish process as the weavers are not involved. There is therefore no supervision nor guidelines in place for the artisan to consider for finishing the kiondos.

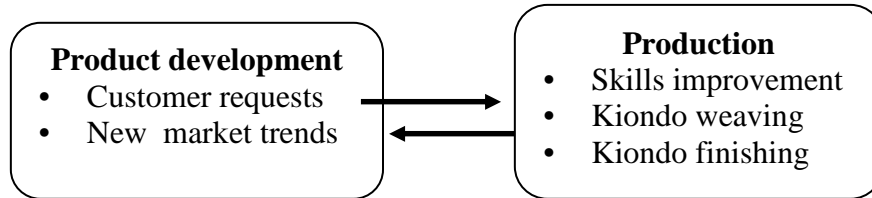

Figure 4.33: Summary of production process at Bahati Co-operative weavers.

Source:Kamuiru,2014.

4.4.4.1 Skills training

Bombolulu Leather workshop

Information gathered from the semi structured interview states the various skills trainings that the artisans have. At Bombolulu leather workshop, the four interviewees all have over 10 years' experience in the leather handicraft sector. The two artisans and the supervisor are directly involved in the production of bags and have attained their skills in various ways. The two artisans have the formal basic 8-4-4 education as per the Kenyan standards despite physical their disabilities. Each one has then received training from a technical institution (polytechnic). According to Bombolulu artisan Chengo who is partial disabled and walks with a limp, the training he received was specific to leather production. Basic skills like material, tools identification, cutting, stamping/decoration and stitching were taught in theory. There were practical sessions where one had to the theory knowledge taught in use. At the training session, one was often put under an apprentice to perfect on the skills that they were able to best execute. Skill perfection in their case was determined by their physical abilities. He emphasises that particular artisans were then good in certain skills and learnt to only work at that skill in leather production. He gave examples of an artisan having perfected leather thonging as a way of joining leather piece or one who only decorated on leather using handheld stamps. Upon completion of

the polytechnic training, an artisan solicited for a job and often it was to work under an apprentice in an established workshop. Chengo mentions that one is able to improve and perfect their skills over the years through experience at work. He has worked as a leather artisan for the last 14 years, 10 of them in the Bombolulu Leather workshop. He emphasize that even with the technology changing with new machines being used, as an artisan one is able to learn how to produce better leather products efficiently.

Dominic, the other Bombolulu artisan interviewed has over 29 years' experience in the leather making industry, He was trained as a certified artisan at Gakeo College in Uganda from 1982 to 1985. He later came back to Kenya and initially apprenticed as a fundi in various small scale producer in the Juakali leather making markets in Ngara and Kariokor markets. For over 7 years he was able to practice and slowly perfect the various skills taught in college. In 1992 he later joined Bombolulu Leather workshops. Dominic emphasizes that skills training and workmanship is perfected through years of experiences. John, the workshops supervisor emphasizes that time is a very important aspect that contributes to the perfecting of artisans skills. He argues that the more times an artisan has done a process, the better he becomes at it. The skills such as pattern making, cutting, stitching, leather thonging, hand decoration, binding and finishing of leather a bag is perfected with time.

SanaBora Design House

The researcher engaged two artisans in unstructured interviews where general questions in regards to their skills training and job experience were asked. The artisans answered freely as they undertook their production duties. Peter, the master craftsman acquired his skills and training at Thika Technical Training school after completing his basic education. After completing his course in 1993 he was employed at Adelphi, a Kenyan company that makes handmade leather products. He worked and gained vast experience in leather bag production at this company until the year 2010. He later joined Sanabora Design house in 2010 as a master craftsman and is currently a member of the production team. Ann confirms that the artisan has perfected his skills over the years and is knowledgeable in all areas of leather production. He is able to efficiently translate bag designs from paper into the actual product as intended by the designer. The artisan is mainly involved in making the initial samples and at the final stage of stitching and finishing the bags. Edith, another artisan employed as a member of the Sanabora

production team artisan is skilled at cutting and stitching the bag pieces. She explains that she was initially trained and gained a years' experience at her previous place of employment at Kikoi Limited. Although the company was involved in garment making, she was able to acquire basic skills in pattern cutting and machine stitching. She joined Sanabora in 2010, and was trained in-house on leather production. She was able to use the basic skills acquired at garment making and translate them as required in leather production.

Bahati Weavers Co-operative

There is usually no formal process of training and production that is followed by the sisal basket weavers. Traditional knowledge and skills over the years have been passed on from mothers to daughters on how to make kiondos for everyday home use. This is still done today among some of the few family members living in rural areas in the Eastern parts of Kenya in Machakos, Makueni and Kitui. Designer Musyoki who hails from this region explains that the skills of his people have not been documented for purposes of future reference. He argues that with the rural to urban migration of people in search of jobs, mothers have no daughters left at home to teach weaving skills. There is also the aspect of modernization and formal education that has introduced vast interest most of them being from the west thus traditional skills are no longer attractive to the young generation.

Bahati Weavers has some of its members who are mother and daughter, who are also passing on the skills to other interested women amongst them. All of the members however joined this co-operative on the basis of knowledge in weaving. Members have a variety of skills in weaving, kiondos, mats, ropes, and hats. Every member has basic knowledge in weaving and some of the women had experience of over 20 years. Some of the new patterns incorporated into the kiondo weaving by the younger members were taught to the older weavers. The researcher observed a middle aged weaver working on a sisal and woolen kiondo with geometric patterns. She was also teaching a much older colleague how to achieve the patterns. The group members teach each other on new skills acquired as explained by Mary who is one of the weavers. The researcher observed that even when the weavers were working on a similar basket designs, the tension of the weaving slightly differed. Some of the women weavers were able to achieve a tight

weave while others had a loose weave. The women explained that this also contributed to the variance in measurement in the intended size.

The artisan observed doing the final finishing the kiondos at Kariokor also has self-taught skills. Kiswilu attests to learning his skills through observing local tailors at work while they made garments. He was able to buy a sewing machine and has taught himself the basics of stitching. He has used the sewing machine for the last 7 years to finish kiondos at the market. He explained that his self-taught skills have improved through experimentation and trying out new designs as requested by customers. He went on to explain that he tries out the particular requests as explained by customers who may want particular finishes done on kiondos. These new designs are what he also proposes to Kiondo weavers for finishing their baskets. At Kariokor market he has two of his colleagues who have learned their basic stitching skills from observation and trying out on the sewing machine. He further explained that he has also taught them some of the finishing skills as they worked.

	Bombolulu Workshops	Sanabora Design house	Bahati Weavers Co-operative
<i>Production processes</i>			
Product Realization	<p>This involves research on the current trends, Product design and development, Ideation and prototype making of the bag. Ideas are represented in simple and detailed sketched forms.</p> <p>Templates and Prototype of the bag were made by the designer.</p> <p>The bags price is worked out from the prototype.</p> <p>Samples are photographed for documentation purposes.</p>	<p>The design team is involved in the research, product development and ideation of the bags.</p> <p>Ideas are represented in simple and detailed sketches</p> <p>The production manager supervises the craftsman in the template making process. A prototype is made and reviewed by the design team. A pre-production of the bag design is done and</p> <p>The cost of the bag is worked out.</p> <p>Each complete sample is photographed for documentation purposes.</p>	<p>The production of kiondo involves ideation and the production of an actual sample by the weaver.</p> <p>The weaver is guided by the customer's request or by new trends observed in the market.</p> <p>Ideas were represented in orally and are observed as weaving is done.</p> <p>A sample size guides the weaver in the pricing of the kiondo.</p>
Production Processes	<p>Production commences with training of artisan that leads to sample bag production. Reference is made to templates and artisan work on bag making from initial</p>	<p>Production processes observed was team work that was done in a step by step manner. Artisans had specific tasks allocated to them as per their skills. The</p>	<p>The first process involved the sisal weaving of the kiondo to completion by the weavers. The second step was the finishing of the kiondo that involved</p>

	process of cutting the pattern, gluing the bag pieces to the complete stitching of the bag. Constant supervision was observed at every stage during production.	processes were; cutting, gluing and stitching, final stitching and finishing of the bag. Each team member is a quality controller and supervision	stitching leather handles, binding, fabric lining and zipper on the kiondo. This was done by an artisan specializing in kiondo finishing.
Skills Training	Artisans have acquired skills training in the production of leatherwork from various technical institutions. They also got basic training on leather machine and tool handling. Artisans interviewed have over 10 years' experience in various leather product making industries.	The artisans interviewed are skilled and have specialized in leather making. The master craftsman was trained in a technical institution and has over 20 years' experience in leather bag making.	The sisal kiondo weavers interviewed explained to having acquired their skills through knowledge passed on to them by the older generation. The artisans at Kariokor with machine stitching skills are self-taught and improve their skills with experience.

Table 4.4: Summary of Production processes from the case studies.

Source: Kamuiru, 2014.

4.5 Summary of Findings

The researcher identified that the producers make an assortment of bags in various shapes and sizes for both the local and export markets. The designs were largely influenced by current market trends. The case studies develop an annual collection of bag designs and each have a trained professional designer that was involved in the product development. The design of the leather bags and sisal kiondos were all geometric in shape. The leather bags were either rectangular or square shapes while the Kiondo was cylindrical. Most of the shapes could be altered as per the bag design. The kiondo sizes varied in measurement per each basket measured and the range sizes were approximated. The sizes of the bags depended on the intended function of the bags. Large sizes of bags were sold as travelling bags while medium and small size

bags were targeted for everyday use. The raw materials used to make the leather and sisal bags were sourced locally having been processed and finished in Kenya. Other materials and accessories used on the bags were sourced from local shops. Tools and machinery used by the producers were bought from local and international sources.

Each case study followed a specific production process to realize their products. Bombolulu and Sanabora have almost similar processes that include research, product development and production. Sanabora includes a pre-production stage as part of its process. Both processes are interactive and often involved a back and forth movement throughout the various stages. The processes were supervised and undertaken at the producers' respective workshops'. The Bahati weavers were seen to have a process that involved two stages; product development and the production of kiondos. Production of the kiondos involved the weaving done in Machakos and kiondo finishing by artisan in Kariokor, Nairobi.

Individually, the case studies have set standards which they follow as per their business practices. Criteria on consistency, dimensions and style were used by the producers as the benchmarks and measures of quality of their products. These were primarily driven by the customer requirements and expectations for the leather and sisal bags produced. In addition, Bombolulu and Sanabora are members of the World Fair Trade Organisation and adhere to their set principles.

In conclusion the quality of leather bags and sisal kiondos produced was dependent on various factors. These include the appropriate raw materials, tools and machinery, the production process, skills of the artisans, the design input and customer requirements. Some of these factors are largely influenced by the financial ability of the producers which is a strong enabler of quality.

Chapter 5 Discussions

5.1 Overview

The product attributes were well executed and were specific in the design of the bags and kiondos to the case studies. The sizes and range are also determined by the intended function of the bag and Kiondo. The case studies have classified and are able to identify the sizes and range available in their bag collections. The artisans are using the locally available raw materials and accessories that are affordable. The tools and machines used in production are sourced both locally and internationally depending on the financial ability of the producer. The advancement in technology has seen various new tools, machines and materials that have influenced the design trends of leather bags. These machines often are costly to purchase and currently producers have to make use of what they have. Thus the limitations are met by modifications of the bag design or even that of the machinery. Some bag designs are usually hand-stitched to acquire the intended design aspect. This situation is seen in the sisal kiondo weavers' case study. The quality of the bags produced was dependent on the production process followed by each case study. The quality aspects given to the producers per the customer requirements in the design briefs were often met.

In regards to proposing an ideal production process, the findings from Bahati Cooperative weavers were not considered. Information from this case study does not allow a critical analysis of the entire production process. This case study is however an example of the current situation that Kenya handicraft producers face. The producers have an informal setup that has an erratic design and production process that has too many gaps. They often rely on customer request to produce a product. It is unknown on what research was undertaken for product development. Production usually starts in one workshop and is completed by another producer at a different workstation. In this setup it is difficult for guidelines to be established and followed in order to facilitate feedback and improved output. The weavers were aware of their need for professional intervention of training in product development that aims to meet market needs.

5.2 The Ideal Production Process

Bombolulu and Sanabora case studies each had a unique set up and adopted a product realization process. In addition, each has set their own standards and were certified World Fair Trade Members. Both identified themselves as brands and each have credibility by way of an international guarantee system. Each of their production process was guided by in-house standards and certification criteria that were used as a checklist to guide them towards producing a quality product. A summary of the production processes from the two case studies was done (see Figure 5.1). The Production processes begun with the research based on the customer's requirements for their products. The case studies have trained designers and marketers who were involved in the research and conceptualization of their product range. Design concepts were presented to skilled artisans who actualize them into products. The set up production processes were seen to be interactive. The information at the various stages related in a back and forth manner. New information and feedback lead to the next step of production. It also ensured that the process was reviewed one step back to improve it thus guiding the artisans towards better outputs. Bombolulu leather workshop placed emphasis on improving the skills and different abilities of the artisans, materials used and marketability of the bags in relation price. Sanabora Design house emphasis was on the function of the product which aims at achieving the best fit for the customer. Other aspects included best business practices in teamwork and in-house skill training for the artisans. Additional artisanal skills have been attained and are largely dependent through on-the-job training and experiences.

The macro and micro factors that influence the overall production process are considered throughout the entire process. The micro factors include the availability of materials, tools and machinery, and the skills of the artisans. The case studies were able to access materials and tools, improve the skills training of artisans and invest in professionals such as designers and marketers. These factors are largely determined by the business goals and the financial ability of the producer institution. Other enablers affecting the production processes from the macro environment include the formal training of artisans, local certification, regional and international standards for quality handicrafts. The various stages observed in the production processes from both case studies were combined to propose an ideal production process for Kenyan handicrafts.

There are various aspects that can be included to the ideal production process to contribute in the production of quality handicraft bags. These are based on their success in the Philippines as seen in the conceptual framework (see Figure 2.7). The researcher proposes the criteria that producers can use as a checklist before proceeding to the next stage of the production process (see Figure 5.2).

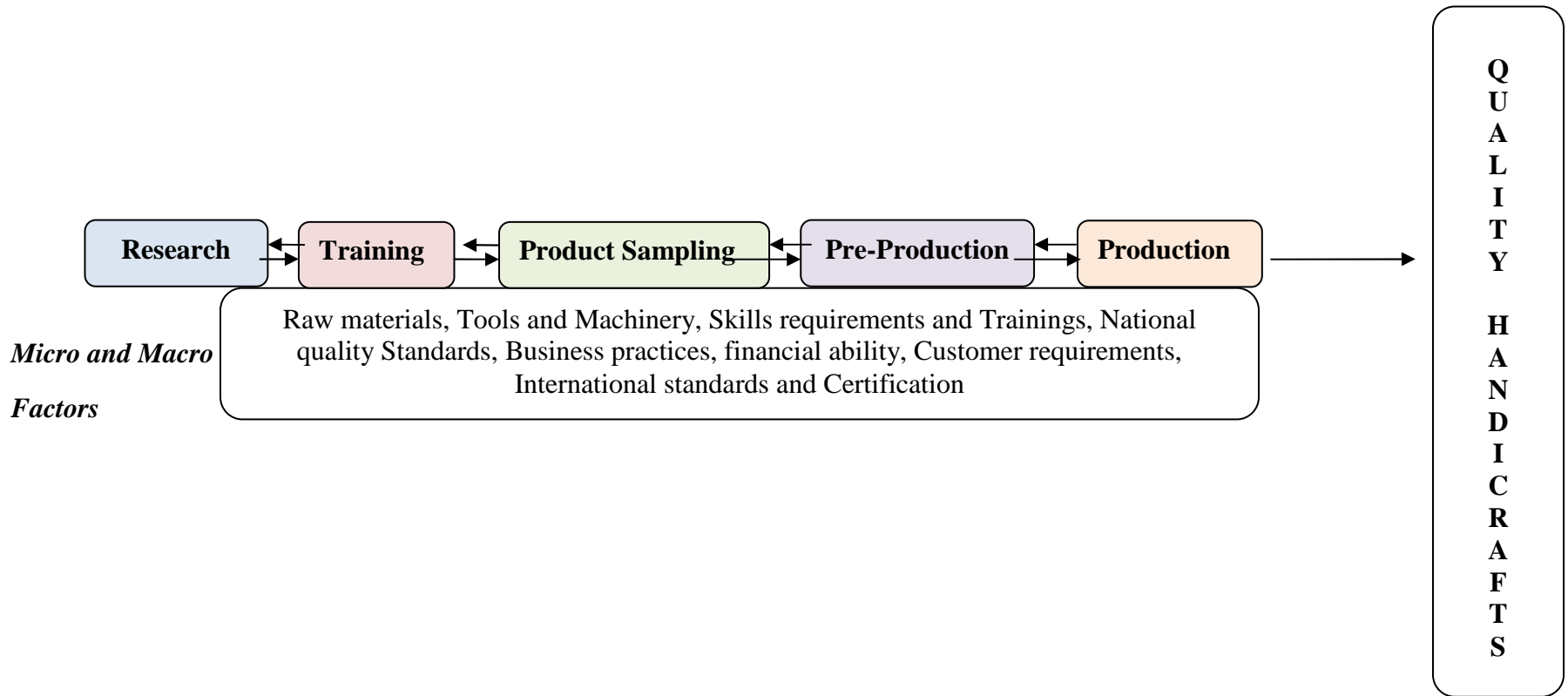

Figure 5.1: Summary of the Production Processes of the 2 case studies

Source: Kamuiru, 2014

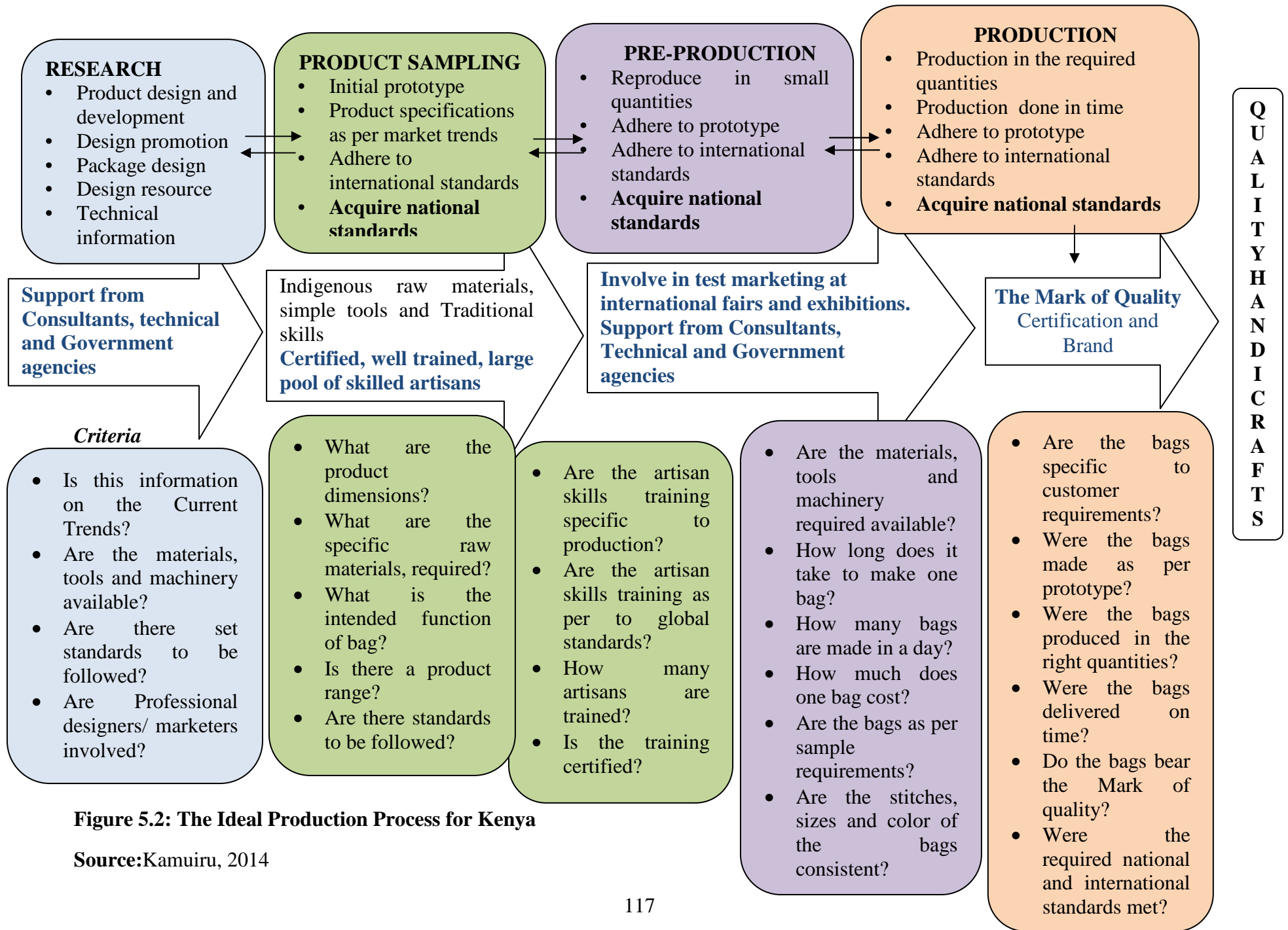

Figure 5.2: The Ideal Production Process for Kenya

Source:Kamuiru, 2014

The first step in the ideal process is research. Producers in both case studies are involved in market research. This involves the gathering of relevant information in regards to the market requirements. The producers also rely on the customer to give their requirements. In the Philippines the handicraft producers invest time and effort to stay current in terms of their product design under a technical agency PDDCP, in the department of Trade and Industry. Producers in Kenya can invest in product research and development, material resources and technical information. They can be supported by relevant stakeholders and the government by linking them with professionals such as designers and marketers whose services can be contracted (refer to Figure 5.2).

Product Sampling is the second step involving the design and conceptualization of an idea and actualizing it into a functional product. The handicraft producers in both case studies engaged the services of a designer in product design who work with the artisans to produce a prototype. The producers adhered to set standards in terms of raw material, tools, measurements as per product brief requirements. They followed in-house guidelines and the international market specifications. The Philippine handicraft producers are guided by current market trends, product specifications, national and international standards that accredit their products with an award of excellence in handicrafts. The case studies can be guided by national standards that require to be set up. At this stage the skills of the artisans are also important. The skills training that artisans acquire in both case studies are informal. Majority of the artisans learn from each other through on the job training and from experience where a lot of trial and errors occur. Technical institutions train artisans on basic skills unlike in the Philippines where training is based on curriculum developed from competency standards. TIVET in Kenya can adopt from TVET training in the Philippines which is based on work that must be performed and materials that are directly related to the competency standards and curriculum modules. Research from the literature review points out that the artisan assessment is based on the performance of work consistent to the industry required standards and training programs are nationally- accredited (refer to Chapter 2.6.2). The product sampling stage can ideally proceed to pre-production with the approval of a sample that has met all requirements.

The Pre-production step prepares the artisans for efficient production. One of the case studies Bombolulu overlooked this process and proceeded with production. The other case study Sanabora included this process in their production. It involved the counterchecking the efficiency of artisan skills, tools and machinery and the availability of materials. These aspects helped to determine the amount required time to produce a bag, the exact quantity of materials and the cost implications. The bags produced at this stage aid in identifying the consistency required for production. These included the execution of skills such as proper stitching, actual measurements of the bag and color of material used. As explained by the designer from Sanabora in the previous chapter, this part of the process was considered essential as the producers get feedback from customers. The necessary changes and improvements were done at this point before proceeding with the final production. In the focus group discussions, Designers Amy, Bee and Minna concurred with this fact. Minna further explained that pre-production bags enabled the final approval for production that is given with certainty. The bags produced were then used for test marketing to gauge the market response. The Philippine producers are involved in test marketing their products before proceeding with actual production. Their handicraft products were exposed to both local and international fairs to test and learn the markets. The case study Bombolulu can get involved in the preproduction of bags and the test marketing. Both case studies can get support from technical and government agencies to attend trade fairs and exhibitions.

The production process involves making of bags in the quantities in the required numbers. Among the case studies, this stage was dependent on the efficiency of the artisans who were expected to meet the production timeline. Product requirements had to be met and bags produced have to be consistent with the approved sample. The existing standards set by international institutions in regards to handicrafts were also required to be met by the producer. The Philippine producers are available in a large pool of well educated, skillful and highly trainable workers thus production in quantities is sufficiently met in time for their markets. Their products are guided by criteria set by regional and international institutions as discussed in the literature review (see Chapter 2.6). In the ideal process, the producers can be guided by national standards that are required. Production efficiency can be met when the required quantities are

produced as per approved prototype specifications within the given time and meeting all the product requirements.

There is no nationally approved mark that identifies quality of handcrafted bags in Kenya. Currently the producers brand acts as their in-house mark of quality for the bag. The membership certification acquired by the two case studies from the World Fair Trade Organisation was also a quality mark of assurance for bags produced. In the Philippines, the Award of Excellence for handicrafts is a “stamp of approval that guarantees that a handicraft product or product line meet the highest standards of quality. It is guided by criteria as discussed in the literature review which has to be met for a product to win the award (see Chapter 2.6). The ideal production process proposes for the inclusion of a national Mark of Quality. This can be used as certification for products that have met all the product requirements. This can be guided by criteria which is counterchecked and approved at each step of the ideal production process (see Figure 5.2). The bags produced through this process which also bear the Mark of Quality will thus be considered as quality handicrafts.

Chapter 6: RECOMMENDATIONS

The researcher recommends the adoption of the ideal production process by the handicraft producers in the production of quality bags. The criteria proposed in Figure 5.2 for use in the production of leather bags and sisal kiondos can also be adopted by other handicraft producers. It can be used as a checklist as it touches on the basics of materials, tools and processes towards quality production. Better quality products mean better lives for producers in terms of earnings and opportunities.

Recommendations for further research are required on standards and criteria that define and identify the measures of the quality of handicrafts in Kenya. The research should be done on a wider scope in the handicraft sector as this research only investigated on three case studies.

The government and private stakeholders should offer support to institutions involved with handicrafts in capacity building. The intervention through institutions would also successfully aid in the implementation of quality criteria and measures. The relevant stakeholders require setting standards that will identify the quality of raw materials and certification of artisan skills training.

The government should also work towards the recognition of handicrafts as a national asset that could generate the country revenue.

References:

- Alexander C., 1964. *Notes on the Synthesis of Form*, Harvard University Press, Cambridge, Ma.
- Atchoerena D., Delluc A., 2001. *Revisiting Technical and Vocational Education in Sub-Saharan Africa: An Update on Trends, Innovations, and Challenges*. International Institute for Educational Planning: Paris.
- Barber T and Krivoshlykova M., 2006. Global Market Assessment for Handicrafts. United States Agency for International Development (USAID)
- Barrett, E. & Bolt, B. (eds.) 2007, *Practice as Research: Approaches to Creative Arts Enquiry*, I B Tauris, London.
- Changing the Change International Conference, 10th-12th July 2008, Turin, Italy.
- CIGS, November 1998. *The South African Craft Industry Report* to the Department of Arts, Culture, Science and Technology.
- Costin, C. L., 2007. *Archaeology at the Millennium*, Craft Production Systems, Springer.
- Cross N., 1977. *The Automated Architect*, Pion Limited, Brondesbury Park, London.
- Cross, N., 1982, 'Designerly Ways of Knowing', *Design Studies*, vol. 3, no. 1, pp. 221-227
- Cross, N., 1999 Design Research: A Disciplined Conversation Design issues, Vol 15, No.2
- Curtis M., N.D., *Developing the Leather Sector in Kenya through Export taxes: The benefits of defying the EU*
- Douglas, M., *Design @ work: The process behind products* Presentation and Exhibition, curated by at the Mint Museum of Craft + Design in Charlotte, N.C. July 7th- October 7th 2001
- Export Promotion Council, 2007. *Supply Survey on Commercial Crafts Produced by Disadvantaged/Marginalized Communities*, Nairobi, Kenya.
- Economic Survey, 2011. *Manufacturing sector*, Kenya National Bureau of Statistics
- Frayling, C. 1993, 'Research in Art and Design', *Royal College of Art Research Papers*, vol. 1, no. 1, pp. 1-5.
- Jones C. J., 1970. *Design Methods*, John Wiley & Sons Ltd., Chichester, UK.

- King, K. 1996. *Jua Kali In Kenya: Change & Development in an Informal Economy 1970-1995*. East African Educational Publishers. Nairobi
- Lambrecht, D. 1981. *African Arts: New basketry in Kenya*, November issue Volume XV no.1 page 63.
- Laurel, B. (ed.) 2003, *Design Research: Methods and Perspectives*, MIT Press, Cambridge, MA.
- Lawson B., 2006. *How Designers Think: The Design Process Demystified*, Routledge
- Maina, S.M., 2012. *Qualitative and Quantitative Research Methods Simplified*, Frajopa Printers Nairobi, Kenya.
- Mäkelä & Routarinne, S., eds. 2006. *The Art of Research: Research Practices in Art and Design*, Helsinki: University of Art and Design Helsinki.
- Marcus G., 2002. *What is Design today*, Harry N. Abrams, Inc., publishers New York.
- Ministry of Education, 2012. Task force report on the re-alignment of the education sector to the constitution of Kenya.
- Morris R., 2009. *The Fundamentals of Product Design*, AVA Publishing SA
- Morris W., 1996. *Handmade Money: Latin American Artisans in the marketplace*
- Mugenda O.M., Mugenda A.G., 2003. *Research Methods: Quantitative and Qualitative Approaches*, Acts Press Nairobi, Kenya.
- Mwiti Evans, 2013. *Determinants of initial export market. Participation among micro and small enterprises in the commercial craft sector in Kenya*, PhD Thesis, Kenyatta University
- Mwinyihija M., 2003. Performance Brief – Leather and Leather Products Division’, unpublished paper, using UN Commodity Trade Statistics
- Mwangi S., 2011. *Enhancing Competencies of Electronic Craftsmen in the informal Sector in Kenya: Is Technical and Vocational Education and Training the answer?* International Journal of Education and Social Sciences (IJESS) Volume 3, Number 1.
- Odundo, Terra Nuova, School of The Arts and Design, University of Nairobi, 2008. *Jua Kali, A process to progress*, Ramco printing works Nairobi, Kenya

- Oduor P.,2013,*Novel ideas, but why isn't anyone buying?* Article in the Daily Nation 19th April 2013
- Rodolfo P. A., Teo J.C. 1995. *Responsiveness to European Market Conditions; A Case Study of Philippine Handicraft Exports to Belgium and Germany*.ASEAN Business Case Studies No 3
- Rowley, S. 1997. *Introduction in Craft and Contemporary Theory*, ed. S. Rowley, Allen &Unwin, Sydney, pp. xiv-xxvi.
- Schön, D., 1991*The Reflective Practitioner: How Professionals Think in Action*, New York: BasicBooks.
- Trowell, M., 1960. *African Design*, Faber & Faber Limited
- The International Trade Center, 2011. *Export Quality Management. An answer book for small and medium size exporters*, Geneva.
- The International Trade Centre, UNCTAD/WTO, World Intellectual Property Organization. 2003. *Marketing Crafts and Visual Arts: The Role of Intellectual Property: A practical guide,Chapter 4 Pg. 43-44.*
- The International Trade Centre Technical paper, 2010. *Inclusive tourism: Linking the handicraft Sector to tourism markets*, Geneva.
- UNESCO, ITC,1997. *International Symposium*. Manila, Philippines
- *Home Accents Today*. 2005.“Trends for '06.” January.
- EU Market Survey. 2005. Gifts and Decorative Articles. November.
- Kenya Leather Development Council Strategic plan 2010-2015. *Leather for wealth-Ngozini Mali*,
- Export Processing Zones Authority report. 2005. *Kenya Sisal Industry*
- *Home Accents Today*. October 2005.“Viewpoints-What are the Major Challenges Facing the Home Accents Industry in the NextFive Years?”
- Walsh, M., 1991. *Education, Training and the Informal sector in Kenya*.
- Yin, R. K., 2003. *Case study research: Design and methods* (3rd Ed.). Thousand Oaks, CA: Sage
- Zaragoza, Sandra & Watt. C.E, 2006. “*Pier 1 Tries to Become Cool Again.*” Dallas Business Journal, February 3.

Websites

- Artisan work. Published on August 28, 2012 *Product design process*. Retrieved on 27th November 2012. From <http://www.artisanwork.org>.
- Training and resources. Retrieved on 28th January 2013. From <http://www.aidtoartisans.org>
- Beth811. 2011. *Philippine-Handicraft-Industry; Their Benefits and Importance*. Retrieved on 17th October 2012. From <http://beth811.hubpages.com>
- CBI. N.d. *About CBI services*. Retrieved on 28th January 2013. From <http://www.cbi.eu>.
- COFTA. 2012. *Fair Trade Monitoring and Certification*. Retrieved on 21st November 2012. From <http://www.cofta.org>.
- *Craftsmanship* by J. Kolko, 2011. Retrieved on 24 Feb. 2014. From <http://jonkolko.com>
- *Craft Oriented Design*. Retrieved on 24 Feb. 2014. From <http://www.ramitareef.com>
- *Craft-oriented-design*, 2012. Retrieved on 24 Feb. 2014. From <http://tiralidesign.wordpress.com>.
- Dana Micucci. Art & Antiques October 2001 issue. *Japanese bamboo baskets hold their charm through the ages*. L'Asie Exotique. Retrieved on 13th May 2013. From <http://www.lasieexotique.com>
- Designerly-Discipline Science.pdf. Retrieved 15th Jan 2014. From <http://oro.open.ac.uk>
- *Design Skills; Past, Present and Future*. Retrieved on 18th Feb 2014. From <http://tdd.elisava.net>.
- EPC. 2012. *Highlights of Kenya's Export Performance In 2011*. Retrieved on 11th October 2012. From <http://epckkenya.org/index.php>.
- Interview with Nigel Cross, by Neeraj Sonalkar, 2008. From <http://ambidextrousmag.org/issues/09/cross.html> Retrieved on 15th Jan 2014.
- Kenya AGOA Strategy Final June 2012. Retrieved on 15 October 2013. From <http://www.competeafrica.org>
- *Kiondo: sisal baskets*. Retrieved on 2^{5th} November 2012. From <http://www.craftofafrica.org>

- Quality and environmental policy <http://www.epzakenya.com> Retrieved on 11th October 2012
- Mukami, Ndungu Sarah. 2012. *Response strategies adopted by handicraft traders in Kenya to challenges of exporting*. Retrieved on 15 October 2013. From <http://www.erepository.uonbi.ac.ke>.
- <http://www.leathermag.com/m/fullstory.php>. Retrieved on 15th January 2013
- *People and prototypes*, Chapters 10. Retrieved on 10th April 2014. From <http://www.designinginteractions.com>
- PCHI. 2011. *Handicraft Industry in the Philippines*. Retrieved on 27th November 2012. From <http://www.pchi.com.ph>.
- Medical education/MedicalEducationNotesSem2/SAMPLESIZE.pdf>. Retrieved on 28th January 2013. From <http://www.saifulbahri.com>
- *Reflection and documentation in practice-led design research*. Retrieved on 25th March 2014. From <http://www.nordes.org>.
- TESDA. Retrieved on 12th October 2012. From <http://www.tesda.gov.ph>
- Turing-05CrossDesign.pdf. Retrieved on 24 Feb. 2014 From <http://viola.informatik.uni-bremen.de>
- UNESCO. 2001. *Award-of-excellence-for-handicraft-products*. Retrieved on 3rd November 2012. From <http://www.unescobkk.org>
- UNESCO. 2003. *UNESCO Convention on the Safeguarding of the Intangible Cultural Heritage*. Retrieved on 10th April 2013. From <http://www.unesco.org>
- Unite for sight.2013. *Importance-of-quality-sample-size*. Retrieved on 28th January 2013. From <http://www.uniteforsight.org>
- *US Commercial Service Standards and Conformity Assessment 2010*. Retrieved on 5th August 2013. From <http://www.ita.doc.gov>.
- *Handicraft industry copes with difficulties*. August 2013. Retrieved on 20th October 2013 From <http://vietnambreakingnews.com>
- *Kenya Vision 2030*. 2011. Retrieved on 14th October 2012. From <http://www.vision2030.go.ke/index.php>

- International Trade Center and World Intellectual Property Organisation. 2003. *Marketing Crafts and Visual Arts: The Role of Intellectual Property. A practical guide.* Free publications. Retrieved on 10th April 2013. From <http://www.wipo.int>
- *Standards Markets Africa*.Kenya-International trade administration. N.D. Retrieved on 8th May 2013. From <http://www.ita.doc.gov>
- *Baskets*.Uganda crafts. 2000. Retrieved on 13th May 2013. From <http://www.ugandacrafts2000ltd.org>

Interviews

- Focus groups discussions. November 28th 2013, December 13th 2014, July 17th 2014, April 20th 2014. Held in Mombasa and Nairobi
- Interviews for consumers. November 22nd 2013, January 17th 2014, April 20th 2014, August 15th 2014. Held in Mombasa, Machakos and Nairobi
- Interviews for professionals. January 17th 2014, March 6th 2014, August 27th 2014. Held in Mombasa and Nairobi

Appendix A

Interview guide for producers

1. Which of the following aspects indicate quality in bags? Rate from highest to lowest
 - a. Materials used?
 - b. Design aspects as per specification?
 - c. Good workmanship (for example straight stitching)?
 - d. Environmental issues?
 - e. Functionality?
 - f. Other?

2. What affects the production of bags
 - a. Training of artisan?
 - b. Level of education of Artisan?
 - c. Tools and machinery?
 - d. Materials?
 - e. other

3. What does quality control mean?
 - a. Good quality materials?
 - b. Good design execution?
 - c. Efficient Tools and machinery?
 - d. Efficient production time and processes?
 - e. Sustainable practices
 - f. Other

4. How is quality controlled?
 - a. Selection of quality materials?
 - b. Efficient production processes?
 - c. Ensuring design criteria is met?
 - d. Sustainable practices?
 - e. Who checks the quality? Counterchecks?
 - f. Other

5. Which is the best selling bag?
 - a. How long has the particular design sold for?
 - b. Who are you selling the product to?
 - c. How many pieces are sold per month?
 - d. How many units are made per month? Time taken for production?
 - e. How many producers are involved in its making?
 - f. Other

6. What is the selling price of bag?
 - a) Who does the price breakdown for the complete bag?

- b) What are the price ranges?
 - c) What is the profit margin/markup?
 - d) How often is the price reviewed?
7. Where are the materials sourced?
- a) How often are the materials sourced?
 - b) In what quantities are the materials bought?
 - c) What are the price ranges?
 - d) Are there alternative sources?
 - e) Do you buy from these sources? Why?
8. Are there alternative materials for use?
- a) Which materials are these?
 - b) Are the alternatives materials available locally? (grown/ produced/processed)
 - c) What are the price ranges?
9. Which machinery/tools are used in production?
- a) Where are the machines sourced?
 - b) Who repairs/services the machines?
 - c) Who trains the artisans on the use of the machines?
10. Who designs the bags?
- a) Who makes the first prototype?
 - b) How do the artisans replicate bag during production of an order?
 - c) Who amends the design for the bag?

Appendix B

Guiding questions for focus groups

- a. What is quality in reference to handicrafts?
- b. What characteristics denote the quality of handicrafts?
- c. Who determines the quality of the handicraft product?
- d. Does the quality of handicrafts have any significance?
- e. Does the price of handicrafts have any significance?
- f. What factors affect quality of handicraft products?
- g. What can be done to improve the quality of handicrafts?

Members of focus groups (product development) held on November 28th 2013, December 13th 2013, July 17th 2014, and in April 20th 2014.

1. Minna -Mifuko
2. Amy- Hiro and Wolf
3. Bee-From Afar
4. Musyoki -Common Interest
5. Suzie- Ngiringiri
6. Kerry-Servv
7. Saphia- Fair Trade Company/People Tree
8. Jenny- People tree
9. Nzisa- Nzinzi designs
10. Wamuo- Bea collections
11. Masinde- Undugu
12. Zohra- Mohazo
13. Everlyne- Imani
14. Nthiwa- Machakos District Cooperative Union
15. Jemimah-Maasai Basecamp

Guiding questions for Consumers

- a) What was considered when buying the bag?
- b. Is the bag well made?
- c. Does it serve the purpose it is intended for?
- d. Are there any faults on the bag? Can the faults be easily recognized?
- e. Is the bag worth the price?

List of consumers interviewed on November 22th 2013, January 17th 2014, April 20th 2014 and August 15th 2014.

1. Lydiah
2. Athman
3. Peter
4. Beth
5. Nyawira
6. Karimi
7. Liz
8. Christine
9. Namiyo
10. Harriet
11. Kanini
12. Teresia-Alice

Guiding questions for Professionals

- a. What aspects are considered in defining the quality of leather and sisal bags in Kenyan handicrafts?
- b. Are there any indicators used to measure the quality of leather and sisal bags made in Kenya?
- c. Are there any policies in Kenya setup in regards to quality of handicrafts?
- d. How do our leather and sisal bags measure up vis-a-vis others producers' bags in the handicraft market?

List of professionals interviewed on January 17th 2014, March 6th 2014, August 27th 2014.

- 1) Beatrice- Export Coach trainer
- 2) Rebecca- Export Promotion Council
- 3) Mwangi- Export Promotion Council
- 4) Njenga- Kenya Industrial Research and Development Institute
- 5) Wanjohi- Co-operative College of Kenya

Appendix C

Observation guide for producers

- a) What design process is used by the leather designer?
- b) What materials are in use besides the leather?
- c) What machines are in use in the workshop?
- d) How many bags are made per day?
- e) What is the production process in use by the artisans?
- f) Who makes which part of the bag?
- g) Are any references are made to patterns or prototypes?
- h) Are there any controls/ measures in place?
- i) Are there any quality checks done throughout production?
- j) If mistakes occur, how are mistakes rectified within production?

Appendix D

Records guide from producers

- a) Are there any sales records for the bags? Monthly? Annual?
- b) What records does the producer have for product development?
- c) What records do the clients send to the producer for product development and production?
- d) Does the producer have records on quality checks?
- e) Are there any records on clients' feedback in regards to the leather bags

Appendix E

Work plan

Date	Activity	End Date
January 2013	Presentation of Concept paper	January 2013 (Completed)
April 2013	First Presentation of Project Proposal	April 2013 (Completed)
October 2013	Second presentation of Project Proposal	October 2013 (completed)
November 2013	Third presentation of Project report	November- May 2014 (complete)
Feb to June 2014	Data collection / Fieldwork	
June –July 2014	Presentation of Project Report with data collected.	June-August 2014(complete)
August– September 2014	Data analysis of research Project findings	July-August 2014(Complete)
September 2014	Presentation of Projects findings and analysis	August 2014(Complete)
October 2014	Final presentation of project findings, recommendations and conclusion	September 2014(Complete)

Estimated research budget

Equipment

Purchase of Research Tools & Materials –	Kshs 10,000
Purchase of Literature Material -	Kshs 10,000
Purchase of Stationery and other writing material –	Kshs 5,000

Travel

Transport & Lunch to various sites for interviews -	Kshs 20,000
---	-------------

Other Costs

Printing, photocopy and binding costs -	Kshs 20,000
Library Membership at various Libraries -	Kshs 5,000
Communication and internet services access -	Kshs 15,000
Miscellaneous Costs –	Kshs 10,000

Total Costs - Kshs 95,000

Appendix F

Below are catalogue pages showing leather bag collections from two case studies



Assorted bags collection Bombolulu leather workshop. **Source:** Kamuiru, 2014

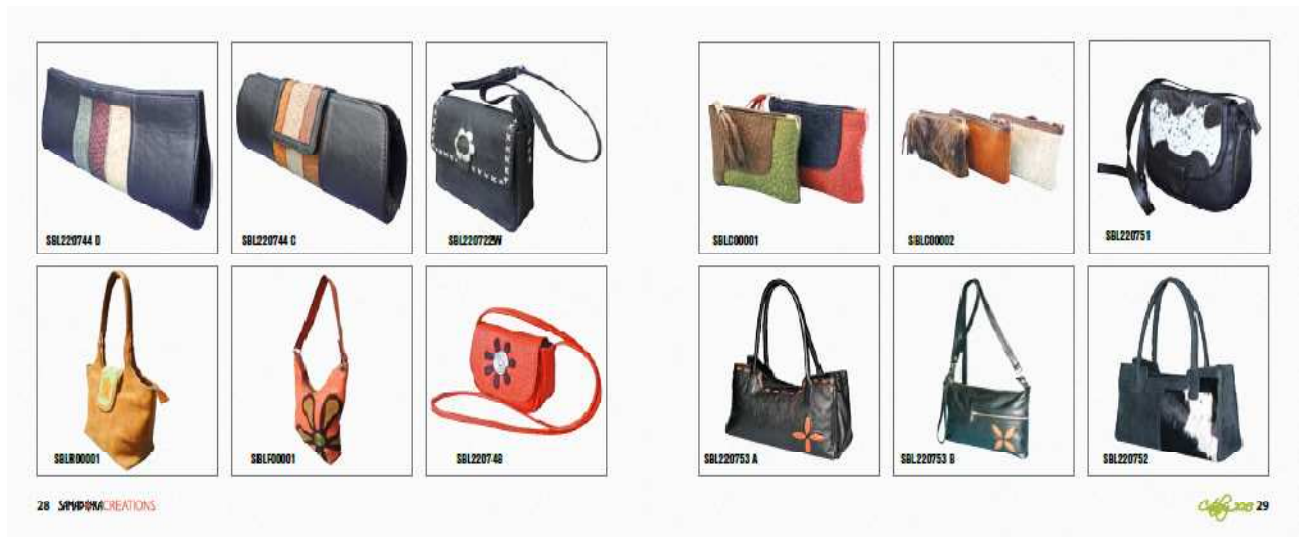

Assorted bags collection from Sanabora Design House. **Source:** Kamuiru, 2014

Appendix G

Handmade leatherbags observed atthe Christmas market salein Belgium.**Source:** Kamuiru, December 2013



Assorted handmade leather bags observed in retail shop in Ethiopia.**Source:** Kamuiru, April 2014



Appendix H



Large sizes of kiondos as observed by the researcher at Kariokor market. This size of kiondo is usually finished with a leather binding that is hand stitched on the kiondos brim. Leather handles are then hand stitched on the opposite sides near the top of the kiondo body. The first kiondo had the two leather strap handles that were hand stitched onto the kiondos body near the top of the baskets brim. The second kiondo had one long handle that was fixed onto the kiondos body. This included having two rectangular leather pieces that were hand stitched on either side of the kiondos body. This leather pieces have a circular hole on the top ends. The leather strap used for the handle goes in through the circular hole and it is knotted in place on both sides of the kiondo.



The small sizes of kiondos observed by the researcher at the weavers market had a long leather handle stitched on either side of the basket. The leather handle measured 40 inches long.



Small size of kiondos with beaded brim finish as observed at the Kariokor Market.

Source: Kamuiru, April 2014

Appendix I



Image showing a range of sisal baskets requested by a client produced by Bahati Cooperative weavers. **Source:** Kamuiru,2014.

The weavers explained that the client rejected the baskets because the coloured shades of the blue dye was not consistent and sizes of the bands differed in all the baskets made.

Appendix J



The researcher observed the ongoing weaving process of a sisal and woolen Kiondo at the Kariokor market. The geometric patterns were incorporated in the design. **Source:** Kamuiru, 2014.

Appendix K



A diversified range of a leather bag design as observed at the Sanabora Design house. It includes three handbag sizes, a coin purse, a small purse, a cheque holder, phone case, a clutch purse and a matching belt.



Bags from Sanabora design house showing a diverse range of leathers used at the workshop. **Source:** Kamuiru, 2014.

Appendix L



Artisan observed using measuring tools to cut out patterns for bags at Bombolulu leather workshop. **Source:** Kamuiru, 2013.