



UNIVERSITY OF NAIROBI  
HOUSING RESEARCH AND DEVELOPMENT UNIT

in association with the

AFRICAN MEDICAL AND RESEARCH FOUNDATION

DESIGN FOR MEDICAL BUILDINGS

A Manual for the Planning and Building of Health Care Facilities under Conditions of Limited Resources

Philip Mein, R.I.B.A., Research Fellow, H.R.D.U.

in collaboration with

Thomas Jorgensen, Consultant Surgeon, A.M.R.F.

University of NAIROBI Library



0356208 9

Housing Research & Development Unit, University of Nairobi  
Director - Jon Skakke M.A.A.  
P.O. Box 30197, Nairobi, Tel. 27441, Ext. 211

African Medical & Research Foundation  
Director General - Michael Wood  
P.O. Box 30125, Nairobi, Tel. 27281

bd 152283

Add

NA

6602

M4M45

2.7

## TABLE OF CONTENTS

<u>INTRODUCTION</u>	pg. 1
<u>CHAPTER ONE - MEDICAL CONTEXT</u>	4
1.1 PARAMETERS	4
1.2 THE RURAL HOSPITAL	5
1.3 ACCOMMODATION REQUIRED	7
<u>CHAPTER TWO - PROJECT PLANNING</u>	10
2.1 THE BRIEF	10
2.2 FEASIBILITY	12
2.3 PROJECT ORGANIZATION	15
2.4 SITE SELECTION	17
<u>CHAPTER THREE - SITE PLANNING</u>	21
3.1 PLANNING METHOD	21
3.2 DESIGN CONSIDERATIONS	25
3.3 ALTERNATIVE LAYOUTS	28
3.4 THE MASTER PLAN	32
<u>CHAPTER FOUR - BUILDING DESIGN</u>	33
4.1 DESIGN METHOD	33
4.2 OUTPATIENT DEPARTMENT AND MEDICAL SERVICES	35
4.3 ADMINISTRATIVE OFFICES	48
4.4 SURGICAL DEPARTMENT	50
4.5 INPATIENT DEPARTMENT	63
4.6 MORTUARY	77
4.7 ANCILLARY SERVICES	78
4.8 HOUSING	82
<u>CHAPTER FIVE - BUILDING CONSTRUCTION</u>	83
5.1 BUILDING METHOD	83
5.2 CONSTRUCTION AND MATERIALS	85
5.3 MAINTENANCE AND IMPROVEMENT	95
5.4 LABOUR AND SELF-HELP	97
5.5 CLIMATE	98
5.6 CONSTRUCTION EXAMPLES	100
<u>CHAPTER SIX - BUILDING SERVICES</u>	105
6.1 WATER SUPPLY	105
6.2 WASTE DISPOSAL	111
<u>CHAPTER SEVEN - CONTRACT PLANNING</u>	117
7.1 CONTRACT DOCUMENTS	117
7.2 TENDERING	125
7.3 APPROVALS	127
7.4 SITE SUPERVISION	127
7.5 COMPLETION AND HANDOVER	130

APPENDIX ONE - ARCHITECT'S FEES	132
APPENDIX TWO - SURVEYING NOTES	134
APPENDIX THREE - ROOF TRUSSES	138
APPENDIX FOUR - SHORT FORM CONTRACT	139
APPENDIX FIVE - BUILDING INSPECTION CHECK LIST	142
APPENDIX SIX - METRIC/IMPERIAL EQUIVALENTS	144
REFERENCES	145

© Copywrite Reserved August 1975

### ACKNOWLEDGEMENTS

The authors gratefully acknowledge the help received from colleagues at the Housing Research and Development Unit and the African Medical and Research Foundation, in particular Flemming Andersen for his contribution to the construction examples in Chapter Five, Jurjen Eygelaar and Charles Hooper for technical advice and Hugh De Glanville for his invaluable help in bringing the draft to its final form.

The typing is by Joen Mein.

The printing is by Kenya National Federation of Co-operatives Limited, Nairobi.



## INTRODUCTION

This manual contains design, construction and cost guidelines for the building and extension or improvement of medical facilities. It has been prepared primarily for the doctor and his staff who, in rural Africa, must often be their own architects. It may also be of value to the architect who, perhaps for the first time in his career, is confronted with the special problems associated with the provision of medical buildings in rural areas. Furthermore, it provides information which could be useful to people who are engaged in raising funds and allocating money for medical purposes in developing countries.

The manual concentrates on the rural hospital which is a reasonably well defined and familiar element in most health systems and which exemplifies many of the functions found in medical buildings both higher and lower in the health care chain. The principles and guidelines herein are considered equally relevant to the design of health centres and dispensaries or to smaller district hospitals.

Hospital buildings at present tend to be excessively expensive, consuming funds which are sorely needed in other areas such as the primary health sector. The guiding principle in this manual is that, for medical buildings, the expenditure of material, monetary and manpower resources should be reduced to the lowest level consistent with adequate and acceptable medical care.

The full range of architectural activity, from initial feasibility study to supervision of the work on site, is covered, the emphasis being that each building problem requires its own solution according to local needs and benefitting from the use of local materials and skills. To this end a considerable amount of space has been devoted to explaining how buildings can be designed from scratch. Where plans are shown they are intended only to illustrate the design principles involved and not as prototype solutions to be applied indiscriminately.

The material in this manual is based primarily upon a study made over a 12-month period by the authors, of some 15 hospitals and health centres in different regions of Kenya and Tanzania. At each place a detailed physical and functional survey was made and discussions with staff recorded. Existing documentation on the subject has been drawn upon as well as the collective experience of the Housing Research and Development Unit in architectural matters and the African Medical and Research Foundation in medical matters.

The recommendations and guidelines contained in this manual do not necessarily reflect either medical or building regulations in force at a particular time. In live situations these regulations may have considerable effect on such items as accommodation requirements and space and construction standards. One of the consequences of this is that, in actual building projects, costs will tend to rise above the levels indicated herein.

**INCEPTION:** State the aim of the project - outline the accommodation required - assess financial, material and personnel resources.

**FEASIBILITY:** Outline responsibilities - determine whether new building is needed - appoint an architect if possible - make detailed list of accommodation - prepare a provisional cost estimate - draw up a program - evaluate, select and survey the site - contact relevant authorities.

ESTABLISH THE FEASIBILITY AND PROCEED WITH THE DESIGN

**SKETCH DESIGN:** Make a diagrammatic plan of the main elements - prepare alternative designs related to the site - select suitable design and show main dimensions, allocation of space and building materials.

**DETAIL DESIGN:** Design each room and fix sizes - decide on construction method and all materials - show position of furniture and equipment - prepare and agree final design drawings - make new cost estimate - obtain outline approval of relevant authorities.

THE DESIGN SHOULD NOT BE CHANGED AFTER THIS POINT

**WORKING DRAWINGS:** Make accurate drawings giving all information needed to construct the works - select all fittings, fixtures and equipment - obtain quotes for special items - obtain building regulations approval.

**BILL OF QUANTITIES:** List all materials and items to be used and their quantities - make final cost estimate - order long-delivery materials - initiate site clearance.

**TENDERING:** Make short list of contractors - issue working drawings, bill of quantities and contract conditions to selected contractors - scrutinize tenders and select the best - make any changes required for cost reasons - sign the contract - nominate subcontractors.

CHANGES BEYOND THIS STAGE WILL COST EXTRA TIME AND MONEY

**SITE WORK:** Agree contractors program - supervise work on site - hold 2-weekly progress meetings with contractor - make interim payments.

**PRACTICAL COMPLETION:** Inspect the work and make list of defects - hold hand-over meeting and accept keys from the contractor.

**FINAL COMPLETION:** Inspect the works and check that the defects are made good - settle final account by releasing the retention sum.

## CHAPTER ONE - MEDICAL CONTEXT

The demand for medical buildings is acutely felt all over rural Africa. It is all too easy in the individual situation to lose sight of the broader context within which any new building project should be seen, the immediate and often urgent requirements tending to overshadow the wider perspective.

### 1.1 PARAMETERS

Before any thought is given to the design and construction of buildings to house medical services, two basic questions should be answered:

- what are the health needs of the population to be served
- into what type of health delivery system does the project have to fit.

health needs

The answer to the first question may seem obvious, but the pattern of disease does vary considerably from one area to another and from time to time within the same area. In the case of a completely new facility, efforts must be made to gain information on the local health situation from medical personnel already working in the area and, most important, from the Ministry of Health. Similarly, population data, including density and distribution characteristics, should be obtained from local sources and from central government.

local involvement

It is important at this stage to involve local people in the decision-making process leading to determination of what kind of facilities are needed. Local leaders will usually be able to provide useful practical information and early community involvement should ease many later problems such as finding a site, the location of water supplies and the supply of local materials and labour for building.

health system

The second question regarding the nature of the health delivery system is equally important. The need for co-operation and co-ordination between the different bodies involved in medical development is paramount. The Ministry of Health will be able to advise on the development plans for a particular area but there may also be ongoing or planned medical projects being run by voluntary agencies or even private companies. All of these factors should be taken into account in establishing the wider context in which the new project must work in the future.

primary and secondary care Health delivery systems vary to some extent from country to country and a great deal of confusion exists in terminology, but the basic concept of primary and secondary health care is generally accepted. Primary health care can effectively and economically deal with the great majority of the medical needs of the rural population. It is an outpatient care and community health service usually offered through dispensaries, health centres and the outpatient departments of hospitals. Secondary care takes over when the patient needs to be treated as an inpatient and this normally takes place in an hospital.

referral chain Whether clearly defined or not, some sort of referral system exists in most places, consisting of a chain of units, in which if one unit cannot look after the patient adequately, he is referred to a unit higher up the chain. In physical terms the chain is usually composed of the following units although precise definitions and terminology vary from country to country:

- dispensary
- health centre
- rural or sub-district hospital
- district hospital
- provincial or regional hospital
- national hospital.

Many of the links in the chain may be weak or indeed missing, especially at the lower end. It is probably true to say that, at present, rural medical development should be primarily concerned with the establishment and consolidation of these vital links in the system.

## 1.2 THE RURAL HOSPITAL

This manual concentrates upon the architecture of the rural hospital in which setting a prodigious amount of building activity is currently taking place. The following describes the situation prevailing in many rural hospitals.

rural hospital The rural hospital is usually a fairly isolated unit catering for, say, 80 - 120 inpatients and something in the region of 300 - 400 outpatients per day. As often as not, it has been built in stages over a number of years with additions having been made from time to time when funds have been available. Usually no master plan has been drawn up and consequently the result is a rambling complex of buildings with little functional cohesion.

constraints

Most hospitals are still overcrowded and shortage of funds, qualified staff and regular supplies are the major constraints. The challenge for anyone working in such a unit is, within the given financial framework, to maintain, improve and extend the services and to make the best possible use of the available staff, buildings and equipment. This calls for considerable organizational effort in a wide range of activities, non-medical as well as medical. It also calls for imagination and an ability and willingness to improvise. Accepted procedures may need to be changed and existing facilities may need modification in order to improve working conditions and, ultimately, the quality of the services.

organization

Outpatient departments are usually overcrowded and often rather chaotic, but the crowds of waiting patients can be divided into groups to be seen at different times during the day or week according to their needs. Pregnant women and children need not wait in long queues together with patients who are attending to have dressings changed or receive their injections; bottlenecks in front of the laboratory or the pharmacy can be avoided through reorganization and rationalization of work procedures.

staffing

The work can be organized so as to have less qualified staff take care of routine procedures, and the flow of patients can be directed in a logical manner from room to room following the sequence of examination and treatment. If a medical assistant has to see 20 or more patients per hour, he must be protected from unnecessary disturbances and noise. The laboratory must have adequate space, and dressings and injections can be done in such a way that a large number of patients can be treated by a minimum of staff in a short time.

use of space

The work in the inpatient department suffers if the wards are overcrowded and beds are allowed in corridors and on the verandahs. The provision of simple and cheap self-care units may dramatically improve the situation. Nursing units scattered over the hospital compound with little regard to their mutual functional relationship with, for example, the theatre block, sterilizing unit and pharmacy can often, by the re-allocation of space, be made to function more smoothly.

design

Operating theatres are often designed with little understanding of the real requirements and small improvements such as floor drainage and better natural lighting and ventilation could go a long way to make them more efficient. In nearly all hospitals the stores are too small with the result that every conceivable corner and niche is taken up by anything from linen and crutches to brooms and buckets. Kitchens



and laundries are often totally inadequate and almost impossible to keep in a reasonable hygienic state. The answer is not electric cookers or spin dryers, but rather provision for employment of more local labour in larger but inexpensive buildings.

The daily work of the doctor and his assistants leaves very little time to cope with this variety of challenges. It is impressive indeed that in many places time and energy are found to improve the prevailing conditions. One major difficulty in carrying out this task is the isolation in which the staff find themselves. Inspiration and advice from others with the same problems are difficult to obtain. With little or no training in financial or personnel administration, the doctor and his staff have to feel their way by trial and error. They are often surprisingly successful, with common sense overcoming many of the difficulties.

Common sense will also go a long way where the extensions and improvements of buildings are concerned, although this is probably the one field where expert advice is most needed and yet most difficult to obtain. It is also a field where the general principles and methods of planning, design and construction can be learned without too much difficulty. Once learned and applied, these principles cannot fail to result in better and cheaper buildings which in turn will add much to other efforts at improving the services.

### 1.3 ACCOMMODATION REQUIRED

Generally, building projects will involve the addition of a new facility to an existing hospital. If, however, a completely new hospital is proposed, then the first question to ask is what size of unit is appropriate?

As far as assessing the demand is concerned, it is often true that the demand exceeds the supply. If this is not the case, then the size of the hospital should be related to the population of the catchment area. In practice, the catchment area extends to the halfway point between the new hospital and other facilities offering comparable services.

A ratio relating the number of beds needed per 1000 population served is commonly used in hospital planning, this figure, however, is difficult to arrive at in an area with no existing medical services. It may be noted that 1.5 beds per 1000 population is often regarded as a target figure in developing countries whereas at the

isolation

architectural expertise

assessing demand

beds per population

other end of the scale some European countries work on a ratio as high as 10 beds per 1000 population. It is impossible to give a general figure, but the following factors should be noted in considering a particular area:

- the existence of other medical units in the area; this may take some of the patient load but may also have caused a greater health awareness tending to increase demand
- the density of population; the more scattered the population, the less visits will be made, but the tendency will be to stay longer
- the efficiency of diagnostic facilities (X-ray, laboratory, etc); if this is high it will reduce the average length of stay and cut down the number of needless admissions.

model

In this manual a rural hospital of around 100 beds is used as a model although much the same design principles would apply to a smaller or larger unit. The type, number and size of individual facilities should be based upon the functional requirements of each unit and its relationship to the total complex, but generally a rural hospital will be composed of the following elements:

- outpatient department
- medical services (laboratory, X-ray and pharmacy)
- administrative offices
- surgical department
- inpatient department (including maternity unit)
- mortuary
- ancillary services (laundry, kitchen, garage)
- housing.

The above categories are related to both functional and architectural criteria although it is appreciated that they do not necessarily conform to hospital organizational groupings. Each element is dealt with in detail in Chapter Four and their arrangement on the site is discussed in Chapter Three.

page 33

page 21



**INCEPTION:** State the aim of the project - outline the accommodation required - assess financial, material and personnel resources.

**FEASIBILITY:** Outline responsibilities - determine whether new building is needed - appoint an architect if possible - make detailed list of accommodation - prepare a provisional cost estimate - draw up a program - evaluate, select and survey the site - contact relevant authorities.

**ESTABLISH THE FEASIBILITY AND PROCEED WITH THE DESIGN**

**SKETCH DESIGN:** Make a diagrammatic plan of the main elements - prepare alternative designs related to the site - select suitable design and show main dimensions, allocation of space and building materials.

**DETAIL DESIGN:** Design each room and fix sizes - decide on construction method and all materials - show position of furniture and equipment - prepare and agree final design drawings - make new cost estimate - obtain outline approval of relevant authorities.

**THE DESIGN SHOULD NOT BE CHANGED AFTER THIS POINT**

**WORKING DRAWINGS:** Make accurate drawings giving all information needed to construct the works - select all fittings, fixtures and equipment - obtain quotes for special items - obtain building regulations approval.

**BILL OF QUANTITIES:** List all materials and items to be used and their quantities - make final cost estimate - order long-delivery materials - initiate site clearance.

**TENDERING:** Make short list of contractors - issue working drawings, bill of quantities and contract conditions to selected contractors - scrutinize tenders and select the best - make any changes required for cost reasons - sign the contract - nominate subcontractors.

**CHANGES BEYOND THIS STAGE WILL COST EXTRA TIME AND MONEY**

**SITE WORK:** Agree contractors program - supervise work on site - hold 2-weekly progress meetings with contractor - make interim payments.

**PRACTICAL COMPLETION:** Inspect the work and make list of defects - hold hand-over meeting and accept keys from the contractor.

**FINAL COMPLETION:** Inspect the works and check that the defects are made good - settle final account by releasing the retention sum.

## CHAPTER TWO - PROJECT PLANNING

Before the design of the buildings can be started, a number of preliminary procedures must be carried out. These include the writing of a detailed brief, the establishment of the economic feasibility of the project, the drawing up of a programme of work and the selection of a suitable building site.

### 2.1 THE BRIEF

definition

The brief is a document prepared by the client; it should state the general aims of the project and list in as much detail as possible all the accommodation required for the new buildings. Each room should be noted with a description of its function, an approximate floor area and its relationship to other rooms. The brief forms the basis for the design of the project whether the services of an architect are available or not.

project team

The brief is usually prepared by a project planning team composed of all those with a legitimate interest in the scheme, the members of which should have their responsibilities clearly defined. The team will be retained for the duration of the project and be responsible for its implementation; it should be small but if possible represent the following:

- the medical officer
- the nursing staff
- the administrative staff
- leaders of the local population
- professional consultants when available.

Representatives from government or other agencies may be part of the team or be co-opted from time to time as appropriate.

teamwork

It is often felt that the most effective committee is composed of one member and indeed this may turn out to be the case either by choice or necessity. If so, that person should confer with all others who are naturally involved and expose himself to criticism in order to avoid reaching too personal a solution. Staff will inevitably change, the aim should therefore be to design and build in a widely acceptable way.

alternatives to new building

Before settling down to write a brief, it should first be decided whether the construction of new buildings is the appropriate response to the medical needs that have been established. It is often tempting to see the solution to a medical problem in the tangible form of bricks and mortar rather than to look in the direction of the reorganization of existing facilities, methods or manpower. The latter may however provide an equally good solution for much less expenditure of both time and money. The consequences of an overly eager attitude to building can be seen in many places where old but sound buildings are made redundant by new construction and where even new buildings go unused due to lack of staff, money or even patients.

existing facilities

An inventory of existing space and its use should be made to see whether, for example, a new facility can be accommodated by simply reorganizing and consolidating existing ones. Sometimes a combination of renovation, conversion and new construction is the correct approach particularly when extending an old facility. For example, if say an X-ray unit is to be added to a hospital it may be sensible to convert an inadequate, poorly lit operating theatre for X-ray use and build a new theatre to a higher standard elsewhere.

location

Another question that ought to be answered before proceeding with the expansion of existing facilities is whether the additional buildings might be better located away from the existing ones where they can serve another part of the catchment area more effectively. There is a natural tendency for established services to grow even after their optimum size has been reached, whereas mobile units or outlying dispensaries may provide a more suitable alternative.

page 33

In the case of completely new development, and in many other situations, the above cautions will not apply. They are included solely as a final reminder before the considerable task of design and construction is embarked upon. If it is found that new building work is indeed the appropriate course to follow, a detailed brief can now be made. The sections on the design of various hospital departments in Chapter Four can be used as a guide.

hiring an architect

The possibility of obtaining professional help should be considered at this stage. The services of an architect should be invaluable for any building project; not only will they ensure a better quality of design tailored to the specific situation, but also an architect's experience in dealing with the administrative and contractual aspects will smooth the progress of the job and take a load from the shoulders of

the medical staff. It is, however, unlikely that architectural services will be available locally and advice from a distance loses much of its value. Most architects will offer a partial service for a reduced fee for making the design; this can be considered but it should be borne in mind that many of the problems for which professional help is needed do not arise until the later contract phase.

selecting an architect

Care should be exercised in the selection of an architect. Preferably one should be chosen who has previous experience of designing medical buildings for rural areas and who is sympathetic with the need to achieve an acceptable solution at a minimum cost. Even architects with experience in medical buildings generally may be used to designing within budgets more generous than are affordable in rural areas and thus may find it difficult to design cheaply. Furthermore, the method of calculating architects fees, based upon a percentage of the total contract cost, is hardly an incentive to stringent economy.

client responsibility

Retaining an architect does not absolve the client from all his responsibilities. He must still provide a comprehensive brief and sufficient background information for the architect to familiarize himself with all the facets of the project. The architect will probably not be able to make site visits as often as ideal; it will therefore fall to the people on the spot to pay special attention to the contractor's work and other local matters. Full co-operation between doctor and architect has often been lacking in the design of medical buildings. In remote areas it is absolutely essential that this co-operation is maintained at the highest level.

architect's fees

Architect's fees can be considered an investment, on the other hand when funds are short, they may be simply unaffordable. Some notes on architect's fees which should be sufficient to make an approximate estimate of their cost for a particular project are given in Appendix One. Finally it may be possible to get architectural help through a volunteer agency or through the national association of architects who may sponsor a free service for deserving projects. In either case the type of service and how soon it can be made available should be established in advance.

page 132

## 2.2 FEASIBILITY

The validity of the project having been established, its economic feasibility must next be ascertained. To do this a provisional cost estimate should be made which



can be compared with the funds available. The first step in preparing an estimate is to assess the total floor area needed.

In the case of additions to existing facilities a preliminary design can be worked out using the design criteria set out in Chapter Four and an approximate floor area arrived at. Where a new hospital is proposed it is impractical to work out the whole design at the feasibility stage merely in order to arrive at an approximate building area. Fortunately it is possible to use a rule of thumb based upon the number of beds required to give a sufficiently accurate estimate of floor area for purposes of provisional costing.

Although the area taken up by each bed is somewhat less than  $2 \text{ m}^2$  the total area required in a ward, where space must be allowed around each bed for nursing and general circulation, amounts to about  $6 \text{ m}^2$ . For each nursing unit of 20 - 30 beds other facilities such as toilets and showers, a duty room, examination room and storage must be included bringing the total floor area per bed required in the in-patient department to  $8 \text{ m}^2$ . When other essential items relating to the inpatients are added, both medical: laboratory, theatre, X-ray etc, and non-medical: kitchen, laundry, central stores etc, the area per bed doubles to around  $17 \text{ m}^2$ . Finally the outpatient department will require between 50 and  $70 \text{ m}^2$  per 100 patients per day adding about  $3 \text{ m}^2$  bringing the total floor area required per bed to approximately  $20 \text{ m}^2$ .

The figure of  $20 \text{ m}^2$  is an average one based upon surveys of a number of hospitals in East Africa taking into account the adequacy of their facilities. It has also been checked against the building designs prepared specially for this manual. It assumes a hospital of around 120 beds with an outpatient department dealing with up to 400 patients a day. For a smaller hospital of say 60 beds the area per bed will increase toward  $23 \text{ m}^2$  because the size of common facilities cannot be scaled down in direct proportion to the number of beds. The converse is also true in that a larger hospital of say 240 beds should require nearer  $18 \text{ m}^2$  per bed.

The above figures will vary according to the situation and the particular facilities provided, but in practice they should be accurate within a tolerance of  $\pm 10\%$ . The total area arrived at should only be used for costing purposes. When the detail design is undertaken, it ought to be possible by careful planning to reduce the area. Staff housing is not considered in the above but it should be borne in mind that this essential item can account for up to 30% of the total building budget.

assessing floor area  
page 33

area per bed space

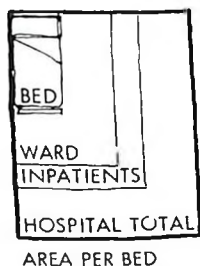

variable factors

accuracy

ref 8

area of health centres

Estimating the area of a health centre by rule of thumb is less reliable due to the wider variation of accommodation provided, particularly with respect to the provision of holding beds, maternity facilities and administration offices. Also the smaller overall area of a health centre makes averaging less dependable. It is however possible to use the outpatient department figure of 50 to 70 m<sup>2</sup> per 100 patients per day to estimate the area needed for diagnostic and treatment facilities of a health centre.

construction standards

ref 8

The next question is to decide the kind of construction that should be used. In 'Medical Care in Developing Countries' Maurice King puts the case for minimizing the capital expenditure on buildings most forcefully saying "Patients should be treated.....in the smallest, cheapest, most humbly staffed and most simply equipped unit that is capable of looking after them adequately". He also points out that generally "There is little relationship between the cost and size of a medical unit and its therapeutic efficiency". To be added to this is the consideration that lower cost buildings using local materials will be more familiar and acceptable to the users. The principle then is to build as simply and economically as possible consistent with medical standards and acceptability.

cost categories

page 84

The criteria for selection of the type of construction and the advantages gained by using local materials are discussed fully in Chapter Five and should be referred to at this stage. For the purpose of preparing a provisional cost estimate however, the three categories listed below can be considered. The prices given are of necessity approximate, being based on the general building situation in Kenya at the beginning of 1975. An inflation rate of 15 - 20% per annum should be added to bring them up to date.

- buildings using substantially non-local materials and skills  
= K sh 1000 (\$140) and above per m<sup>2</sup>
- buildings using partly local materials and skills  
= K sh 700 (\$100) approximately per m<sup>2</sup>
- buildings using mainly local materials and skills  
= K sh 500 (\$70) and below per m<sup>2</sup>.

other categories

Buildings made entirely of local materials such as mud and wattle and thatch, suitable for self-care wards and some staff quarters, can be built at very little cost, especially if constructed on a self-help basis. A further category would be temporary buildings constructed of simple materials such as timber and corrugated

iron which can be reused. An urgently needed facility can thus be accommodated quite satisfactorily until such time as a more permanent structure can be erected.

No medical buildings should fall into the first category. Some, such as the operating theatre, laboratory, X-ray unit and toilet blocks (about 30% of the total floor area) will be in the second, the remainder falling into the third category. It is not necessary or desirable to build all hospital buildings to the same standard.

total building cost

From these figures a composite cost per  $m^2$  can be arrived at and the overall construction cost can be worked out thus:

$$\text{NUMBER OF BEDS} \times \text{AREA PER BED} \times \text{COST PER } m^2 = \text{CONSTRUCTION COST} .$$

The following items expressed as percentages of the construction cost should be added to this figure:

- 15-20% for site development
- 15-20% for furniture and fittings
- 10% for contingencies
- an amount for professional fees
- the cost of the site.

In some cases materials, labour or land may be donated; if so, their value should be assessed and deducted from the total. The above figures do not cover medical equipment and supplies. This last figure now represents the total capital cost and can be compared with the available budget to establish the economic feasibility of the project.

phasing

One way of cutting initial capital costs is to phase the development over a number of years, this may in any case be necessary due to limited availability of materials or labour. The disadvantage is that with inflation even at the low rate of 10% over say a 10 year period, the cost per  $m^2$  for the last buildings will be more than twice that of the first. It will also require a large yearly income to meet both escalating building and running costs. If phased development is decided upon, it is essential that a plan for the final building is made at the outset, otherwise confusion is likely to ensue.

### 2.3 PROJECT ORGANIZATION

Having established the feasibility of the project and made the decision to proceed, a project programme should be drawn up outlining the sequence of tasks to be

FIGURE 1  
sample programme

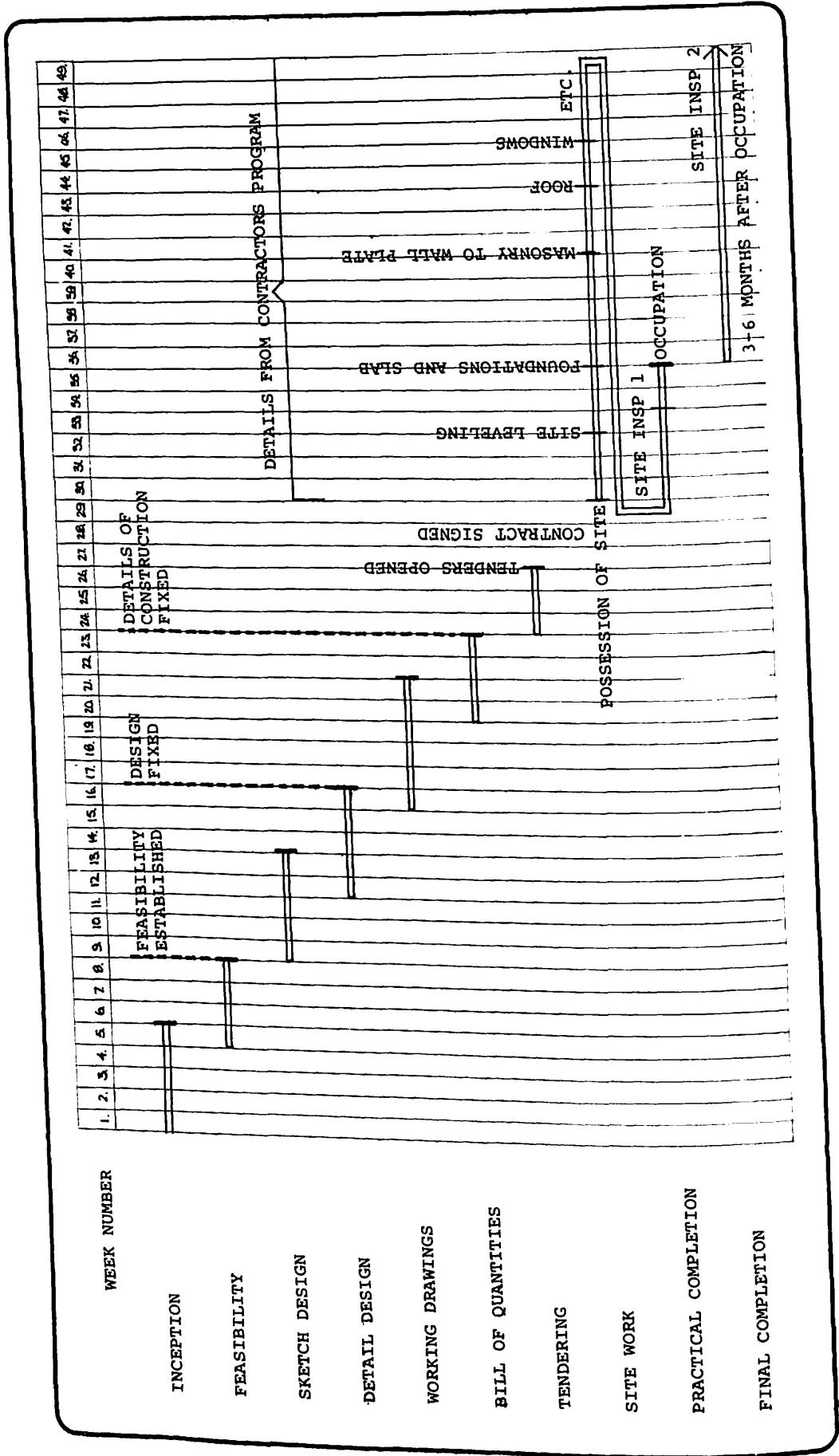



undertaken and allotting a time period for each. The sequence of work common to all building projects is set out in summary form at the beginning of each chapter and the specific stages are described in detail in the relevant sections of the manual. This information combined should be sufficient to draw up a programme for a particular job.

project programme

To complete the programme a time period must be allotted to each stage and an overall length of time fixed. Figure 1 shows a programme for a hypothetical building project of medium size such as the addition of a new maternity unit. The time scale shown is a relative one relating the time for each stage to the duration of the whole job. The actual time periods in terms of weeks can only be assessed in the light of each set of circumstances. Seasonal variations in rainfall particularly should be noted as they can effect the building programme considerably. What is important is to see which activities may overlap and which can only be started after the preceding one has been completed. A properly prepared programme referred to regularly, should reduce to a minimum the delays so often caused by an incorrect ordering of the work sequence.

selection of a contractor

Some of the later tasks may require action at an early stage, particularly the selection of a contractor. In many rural areas there will be no choice of contractor, in this case, or where for other reasons the choice is obvious, then the earlier the contractor is approached the better. A local contractor is in the best position to advise on the type of materials and construction available locally; he can also give some indication of the likely cost and time the project will take. Do not enter into any agreement at this stage; a number of precautions and safeguards are necessary first, particularly with a contractor who is virtually certain to get the job.

page 121

It may be necessary to order in advance certain basic building materials for which a long delivery time is expected. Also hospital equipment, some of which may come from overseas, should be ordered in good time.

## 2.4 SITE SELECTION

The remaining task before designing the buildings is the selection of a suitable site. In the case of extensions or, for example, where land has been donated, the location will be predetermined, but where there is a choice, a number of criteria must

be taken into account. Even a donated site should be rejected if it falls short on too many of the following considerations.

site area

There is no limitation in building so severe as the shortage of space; it is therefore essential that any site is easily capable of providing for all present and future needs. Bearing this in mind, and that for reasons of economy, flexibility and amenity, the layout of departments will be fairly spread out, the site area for say a 120-bed hospital and housing should be at least 4 ha (10 acres), whereas a health centre requires about 1 ha (2.5 acres). Both these site areas have been determined after studying a number of medical units and they are average figures. It would be quite possible to build on less space if need be, but in cases where no cost is involved, such as the allocation of government land for a government hospital, considerably larger areas could be reserved.

location

The location of medical facilities is vital to their successful operation. They should be sited close to the centre of the population served, preferably near the largest village, and be well connected to the regional communications network. This will not only be convenient for the largest number of patients but will aid in bridging the commonly experienced gulf between hospital and community. Having stressed the importance of proximity to the community, it should be said that areas emitting noise and pollution or harbouring disease-carrying insects, for example, factories, main roads, rubbish tips, and stagnant water, must be avoided or certainly kept down wind.

selection criteria

The determination of the size and preferable location for the site will cut down the choices considerably; even so all possible sites should be further checked against the following considerations.

topography and vegetation

A hilly site, though invariably more expensive and difficult to develop, may provide opportunity for a more pleasant design with possibilities of views and good ventilation. Slopes greater than 1:12 are too steep for easy walking and sites on top of hills should be avoided. Good ground cover is a great asset which apart from enhancing the visual and thermal environment, is a good indication of the prospects for a future hospital garden.

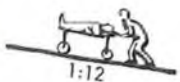

local climate

In hot areas, north or south facing slopes attract less solar radiation and are therefore desirable; more important, they facilitate the orientation of the building so that it faces north and south. In hot, humid areas, however it will be more important to catch the breeze. In highlands, a slope which catches the early morning



drainage and subsoil

sun is welcome. In areas where the nights are cold, the bottoms of valleys or depressions should be avoided if possible as they are the coldest. In arid areas exposed sites are to be avoided due to the nuisance of dust storms.

A site which has good natural drainage will be easier to build upon, will not flood or cause mud holes and will be unlikely to harbour insect breeding grounds. The bearing capacity and stability of the ground will affect the cost of foundations. Heavy clays which are liable to expansion when wetted should be avoided particularly in flood situations. Sands and gravel are generally good except on sloping sites where erosion can be a problem. Rock is good for foundations but is difficult to remove if the site has to be levelled. Test holes should be dug to a depth of at least 1 m to establish the subsoil conditions and, if any doubts arise as to the suitability for building, samples should be taken for analysis by an engineer.

services

It is doubtful whether any main services will be available. Electricity can be generated, sewage can be treated in septic tanks, but a plentiful supply of good water is imperative. This must be established beyond doubt. Water supply is discussed more fully in Chapter Six but a source capable of giving 200 litres per hospital bed per day would be adequate.

page 105

existing buildings

Existing buildings are generally an asset either for use as ancillary buildings (hostel, garage, stores etc) or for reclaiming building materials for use in new buildings.

ownership

Ownership may appear clear but should be established beyond doubt. The government department responsible for land development and planning will usually be able to advise on ownership and if the land is registered the owners' name will be found in the land register. The local authority should be consulted as to whether there are any planning controls affecting the use of the site or any public rights of way crossing it. The land should be clear of any restrictive covenants which might affect the freedom of development.

Finally, before plans can be drawn up a survey of the chosen site must be carried out. This does not need to be an elaborate affair, but should incorporate the features described above and their position, the overall dimensions of the site, and all changes in level. Notes on making a rudimentary survey are included in Appendix Two.

page 134

**INCEPTION:** State the aim of the project - outline the accommodation required - assess financial, material and personnel resources.

**FEASIBILITY:** Outline responsibilities - determine whether new building is needed - appoint an architect if possible - make detailed list of accommodation - prepare a provisional cost estimate - draw up a program - evaluate, select and survey the site - contact relevant authorities.

ESTABLISH THE FEASIBILITY AND PROCEED WITH THE DESIGN

**SKETCH DESIGN:** Make a diagrammatic plan of the main elements - prepare alternative designs related to the site - select suitable design and show main dimensions, allocation of space and building materials.

**DETAIL DESIGN:** Design each room and fix sizes - decide on construction method and all materials - show position of furniture and equipment - prepare and agree final design drawings - make new cost estimate - obtain outline approval of relevant authorities.

THE DESIGN SHOULD NOT BE CHANGED AFTER THIS POINT

**WORKING DRAWINGS:** Make accurate drawings giving all information needed to construct the works - select all fittings, fixtures and equipment - obtain quotes for special items - obtain building regulations approval.

**BILL OF QUANTITIES:** List all materials and items to be used and their quantities - make final cost estimate - order long-delivery materials - initiate site clearance.

**TENDERING:** Make short list of contractors - issue working drawings, bill of quantities and contract conditions to selected contractors - scrutinize tenders and select the best - make any changes required for cost reasons - sign the contract - nominate subcontractors.

CHANGES BEYOND THIS STAGE WILL COST EXTRA TIME AND MONEY

**SITE WORK:** Agree contractors program - supervise work on site - hold 2-weekly progress meetings with contractor - make interim payments.

**PRACTICAL COMPLETION:** Inspect the work and make list of defects - hold hand-over meeting and accept keys from the contractor.

**FINAL COMPLETION:** Inspect the works and check that the defects are made good - settle final account by releasing the retention sum.

CHAPTER THREE

CHAPTER FOUR

CHAPTER FIVE

CHAPTER SIX



## CHAPTER THREE - SITE PLANNING

The sensible development of available land will greatly affect the success of the project, not only initially but for the entire life of the hospital, health centre or dispensary. This chapter deals with the arrangement of the main building elements on the site and the drawing up of a master plan.

### 3.1 PLANNING METHOD

No two building problems are identical; the variables of needs, topography and climate as well as the personalities involved, combine to make the application of any standard solution a gross over-simplification. Consequently, no prototype plans are proposed but rather a sequence of diagrams showing the functional relationships that exist within a hospital and an analysis of the various types of building arrangements that can be produced.

In the case of the hospital, one can think of buildings in terms of those belonging to a nucleus of medical departments whose relationship to one another is critical, and a periphery of supporting buildings which serve the medical functions, the precise location of which is less critical. Even so the design of the nucleus should not be carried too far without a clear idea of the distribution of the peripheral elements on the site.

FIGURE 2  
the nucleus simplified

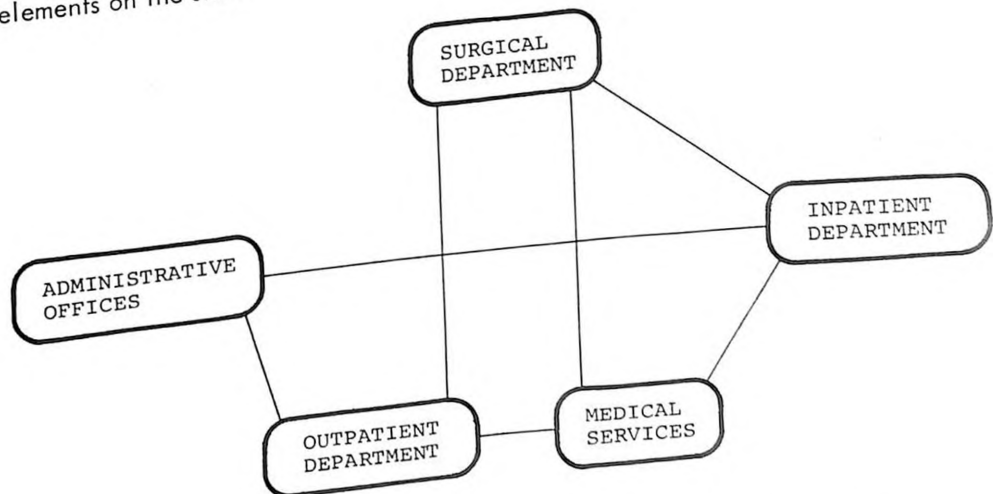

the nucleus

Figure 2 shows the five basic elements of the nucleus: the administration, outpatient department, medical services (laboratory, X-ray etc), surgery and inpatient department in the form of a relationship diagram. The lines connecting

the boxes indicate a functional relationship which, if translated into physical terms, would manifest themselves as routes for the movement of patients, staff or goods. This type of diagram is the architect's basic planning tool and can be used in solving planning problems of any scale.

The object of the exercise is to position the elements of the plan in such a way as to minimize the length and complexity of the connecting lines. In practice this can be done by sketching several alternatives and selecting the most successful, or by cutting out pieces of paper representing each element and moving them around until a satisfactory arrangement is found. The arrangement should take into account what might be needed in the future as well as initial requirements.

relationship diagram

The next step is to break each department down into its constituent parts and repeat the operation as in the example in Figure 3. The diagram becomes more complex and it is impossible to arrive at an ideal arrangement. Compromises have to be made and some longer lines, determined by the volume and type (patients, staff or goods) of traffic the routes are expected to carry, accepted.

FIGURE 3  
nucleus relationship  
diagram

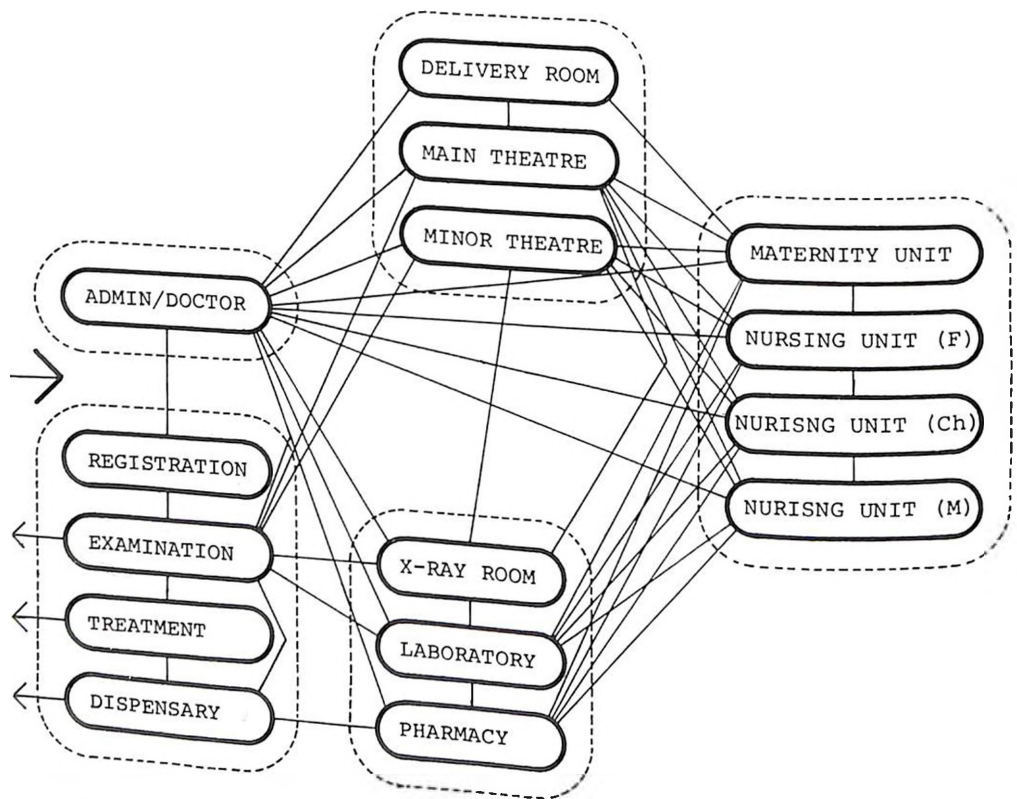

the first plan

The abstract relationship diagram with its many connecting lines in all directions can be rationalized to produce a plan which, although still diagrammatic, is much



closer to a positioning of actual buildings with the connecting lines now approximating to major and minor pathways. This can be done in a number of ways, depending upon the planning approach, site characteristics and personal preference. Figures 4 and 5 show two alternatives, the first using a central spine arrangement with branches off it, the second based upon a gridiron system of circulation. The pros and cons of these and other systems are discussed later in this chapter.

FIGURE 4  
the nucleus linear form

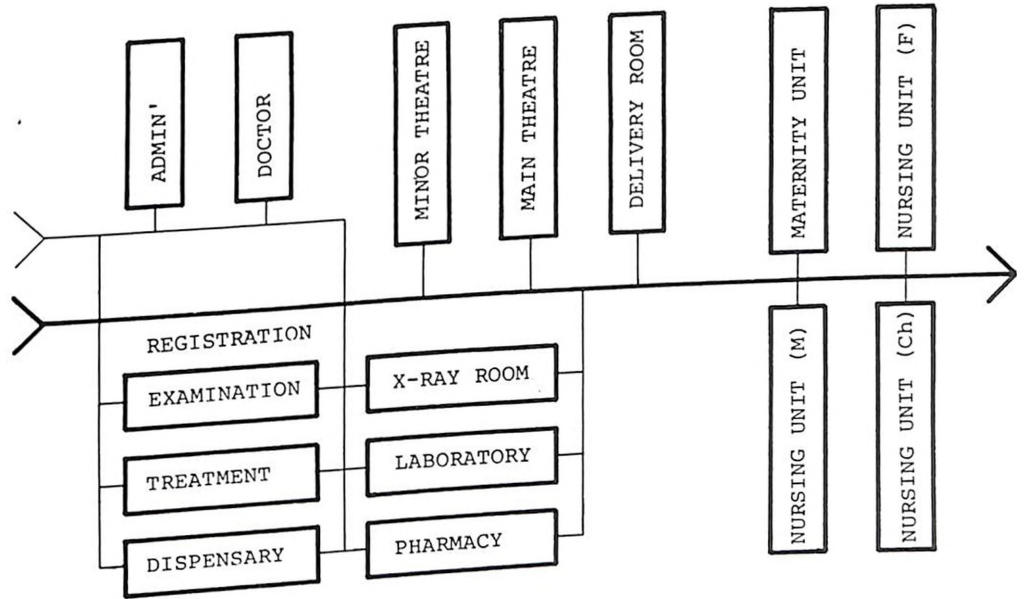
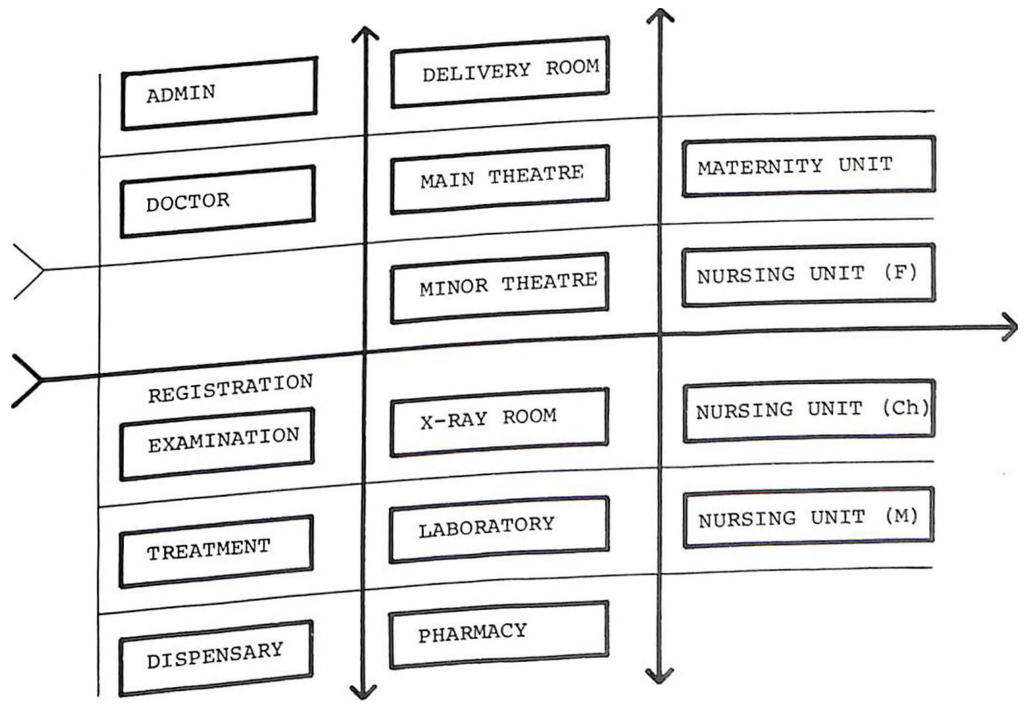

FIGURE 5  
the nucleus in grid form



the periphery

Although the locational requirements of the peripheral buildings are not so stringent, there are some factors to be taken into account in positioning them around the nucleus:

- all buildings have an obvious connection with at least some part of the nucleus
- any function likely to cause air pollution (smoke or smell) should be to the leeward side of the nucleus
- most buildings, particularly the garage and main stores, will require vehicular access
- staff housing will probably be situated on the most attractive part of the site, but should not be too close to the nucleus in order to provide some off duty peace and quiet. Conversely the noise from staff quarters may be disturbing to patients in the wards
- most important of all is that peripheral buildings should never be placed in such a way as to restrict the future expansion of the nucleus.

These factors are shown diagrammatically in Figure 6.

FIGURE 6  
periphery relationship  
diagram

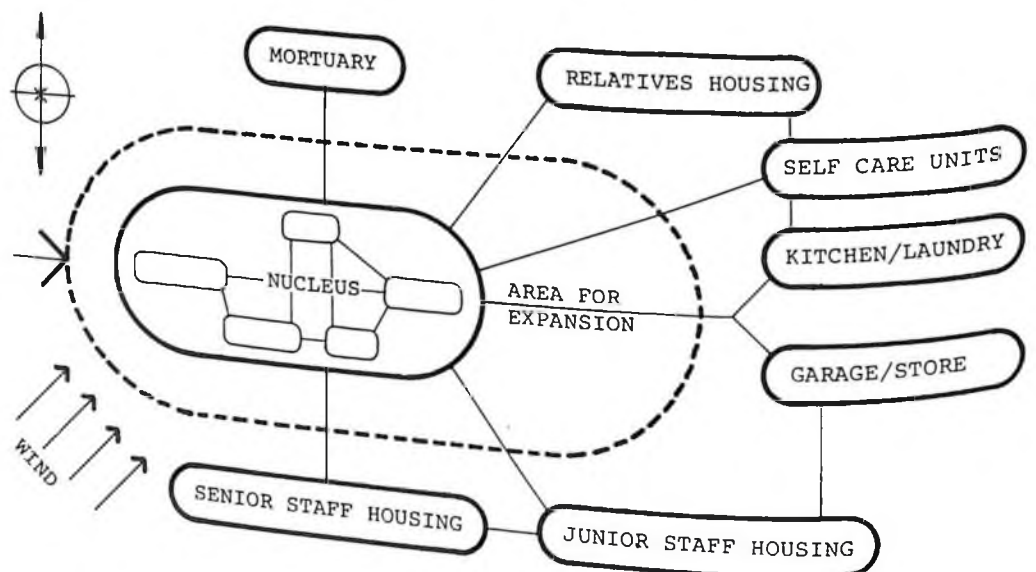

adding new buildings

Although Figures 2 - 6 and accompanying text refer to the development of a completely new hospital, the same methodology can be applied to a smaller unit or to the addition of new buildings to an existing hospital. In the latter case the drawing up of a relationship diagram can highlight the causes of existing bottlenecks and needless walking, in which case the strategic positioning of a new building, perhaps coupled with the change of use of some existing ones, can result in an improvement of the functioning of the entire hospital.



health centres

The site planning for a health centre is a simpler matter but the same principles apply. The main elements of diagnosis and treatment are similar to those in the outpatient department of a small hospital. Besides this there will probably be a laboratory, health administration offices, a small maternity unit and a few holding beds. Clinics may be held in the main building or have their own accommodation. Figure 7 shows a relationship diagram for a health centre from which a simple layout of one or two buildings can be envisaged.

FIGURE 7  
health centre relationship  
diagram

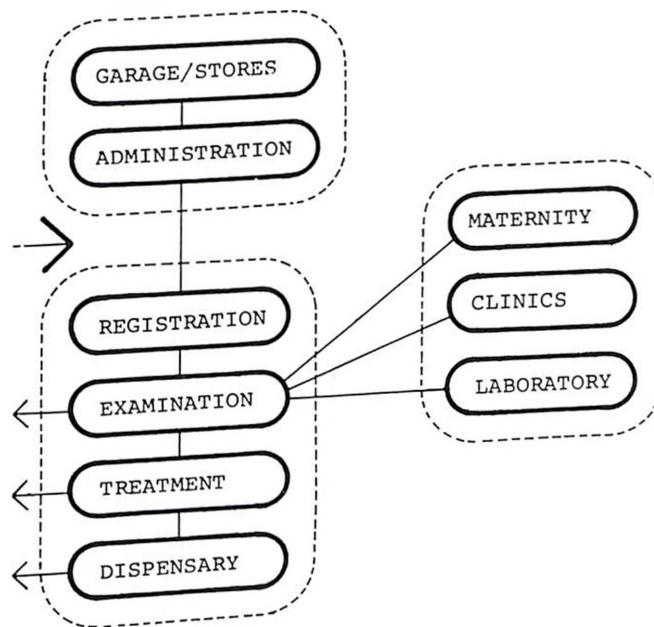

### 3.2 DESIGN CONSIDERATIONS

For a successful and workable building, the functional relationships described above must be satisfied. There are, however, other factors both objective and subjective which have considerable impact upon the eventual shape of the hospital.

climate

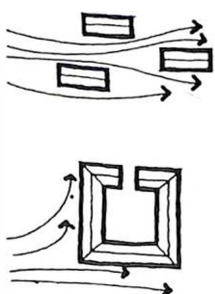

The climatic zone in which the site falls must be established and, if possible, climatic data should be studied and local knowledge tapped. Generally, however, in tropical countries the sun should be excluded by facing buildings north and south and any available breeze should be caught, except in highland areas where some sun penetration might be welcome and where high winds may have an excessive cooling effect. Open arrangements of buildings allow for greater ventilation but at the same time provide less protection against high winds and dust storms. The converse is true for enclosed arrangements such as courtyards and squares. A sufficiency of natural light is not normally a problem in tropical areas

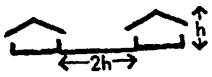

but generally the faces of buildings requiring light should not be spaced closer together than twice their height.

sound and noise

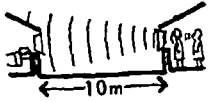

The problem of sound is usually that of the reduction of noise. Buildings should be spaced 10 m apart for conversational privacy when windows are open. Courtyards are noisy especially if they have a hard ground surface such as concrete and parking areas should never be surrounded on three sides by buildings. Soft ground surfaces such as grass absorb sound. External noise sources are best controlled by solid walls, the nearer the source the better. Trees and foliage are fairly poor sound barriers, tending only to diminish high frequency noises.



topography



The contours of the site will affect the choice of building type. Diffuse arrangements of smaller units are the most adaptable for undulating sites. Longer buildings should run with the contours. Flat sites present fewer building problems but may need special drainage provision. Building in depressions should always be avoided. Variations in level, although a problem in some ways, should be regarded positively in that they can provide pleasant views, good ventilation or protection from strong winds and a reason for a more imaginative arrangement of buildings.



expansion

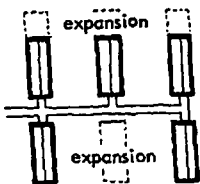

The layout of buildings should be loose enough to allow for growth, but extra money should not be spent in anticipation of future expansion which may not take place and which in any case may not be desirable. It is ideal to allow for the extension of individual buildings by leaving space beyond the gable end of each block and for the addition of further units by setting aside zones for expansion within the master plan. The future growth of the circulation and services networks should also be considered.

construction

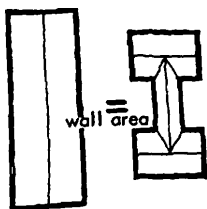

The size of buildings should, as far as possible, be standardized in order to reduce costs and allow for future changes in use. This particularly applies to the cross dimension which, if kept constant, enables standardization of the roof construction whereas the length of the building can be varied incrementally. Simple rectilinear blocks are the easiest, and therefore cheapest to construct although there are other planning and aesthetic criteria which may work against this. External walls are expensive, making small buildings and those with highly articulated facades more costly per unit area.

soil conditions

Parts of the site with poor subsoil should be avoided. For foundations the best soil is sand or gravel. Heavy clays are liable to swell dangerously when wet whereas

soft clays may give under load, causing cracking. In very wet areas fine sand can become 'quick' and move under the foundations. Organic soil (peat) is unacceptable for building, and filled land, unless of well compacted sand or gravel, should be avoided.

services

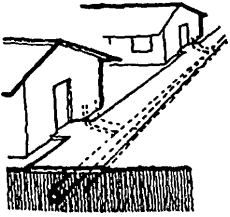

The connection of services such as sewerage and water supply is always expensive. Buildings should therefore be arranged in such a way that these connections are as short and direct as possible. This particularly applies to those parts of the building such as toilet blocks and laundries which consume most water and dispose of most waste material. Due to the frequent maintenance required by most services, the main runs should be easily accessible, for example running at the side of foot paths or roads, and should never have to run beneath buildings. Supply services such as water and electricity can sometimes be accommodated in the roof structures of the buildings and covered ways where they can be very easily maintained.

architectural quality



There are also subjective considerations which are no less important for being a matter of personal choice. A plan consisting of rows of identical blocks may be efficient, but if it looks like a prison to the occupants then much of the advantage is lost. The character of the medical unit and its acceptability to both patients and staff is determined by the shape of the buildings and the spaces between them. Outside spaces are important and often have a function and character as clear as inside spaces. They should therefore be designed in a deliberate way as 'outside rooms' which people will use for working, relaxing or even for the temporary storage of furniture while adjacent rooms are being cleaned. Well defined spaces are more useful and pleasant to be in than spaces which are merely the left-over areas between the buildings.

landscaping

Both the preservation of existing foliage and new planting is of the utmost functional and psychological benefit. Not only is the shade afforded by trees almost always welcome, but more general planting can have an overall cooling effect through the absorption of solar radiation and by evaporative cooling. Trees are also useful for defining outside spaces and providing windbreaks though care should be taken not to build too close (2 - 3 m) to existing large trees because of the risk of damage to foundation walls by roots. Good ground cover reduces unpleasant reflected glare and the nuisance of wind blown dust. Finally, the planting of a vegetable garden besides providing a reliable source of food can serve as an outdoor classroom for nutrition education.

### 3.3 ALTERNATIVE LAYOUTS

The preceding diagrams and guidelines can be expressed in terms of different building layouts which satisfy the various requirements to a greater or lesser degree. This poses no problems for dispensaries and health centres where only one or perhaps two blocks are involved but for hospital buildings several quite different alternatives are possible. Figures 8-10 show three basic types of plan suitable for the nucleus of a rural hospital and some variations on these are described below.

linear alternatives

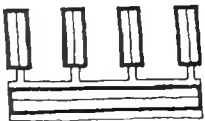
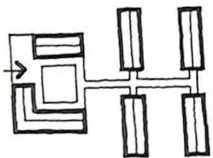
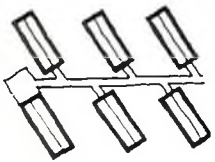

The buildings can be set at an angle to the spine providing improved ventilation possibilities, views from the buildings and the dispersal of noise. By varying the angles and spacing of the blocks along the spine, contours can be followed and uneven areas of the site avoided.

The repetitive nature of a linear plan can be alleviated by grouping the more public facilities into a square giving a better sense of 'place' and a clearer separation of outpatient and inpatient departments.

Alternatively the outpatient department and medical services can be positioned along the spine giving direct access from both in and outpatients whilst keeping them separated. This gives a good compact plan although in hot areas where north and south facing buildings are advisable it is unsatisfactory.

rectilinear alternatives

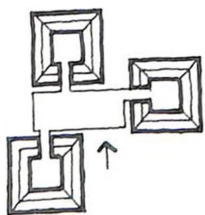

Other types of plan falling into this group are those where the buildings are set around a rectangular open space. The single square is only suitable for smaller units and has the distinct disadvantage in tropical countries that some of the rooms are bound to face east and west. Also squares are 'closed' arrangements, which are difficult to add on to in a sympathetic way, as opposed to grids and linear types which are 'open'.

Courtyard plans are similar in effect to the gridiron with many of the same advantages. It is possible to avoid orientation problems by positioning less used rooms such as stores on the east and west faces. It is also more adaptable to uneven sites than the larger square which involves steps or ramps in the building to take up changes of level. Both square and courtyard schemes tend to provide the pleasant environment normally associated with well defined spaces and each provide ample protection from high winds and dust storms which can make linear or dispersed arrangements very unpleasant.

the linear plan

The linear system of planning is extremely adaptable lending itself to many variations. Figure 8 shows the simplest arrangement in which the various departments are positioned at right angles along a central circulation 'spine'.

FIGURE 8  
linear plan

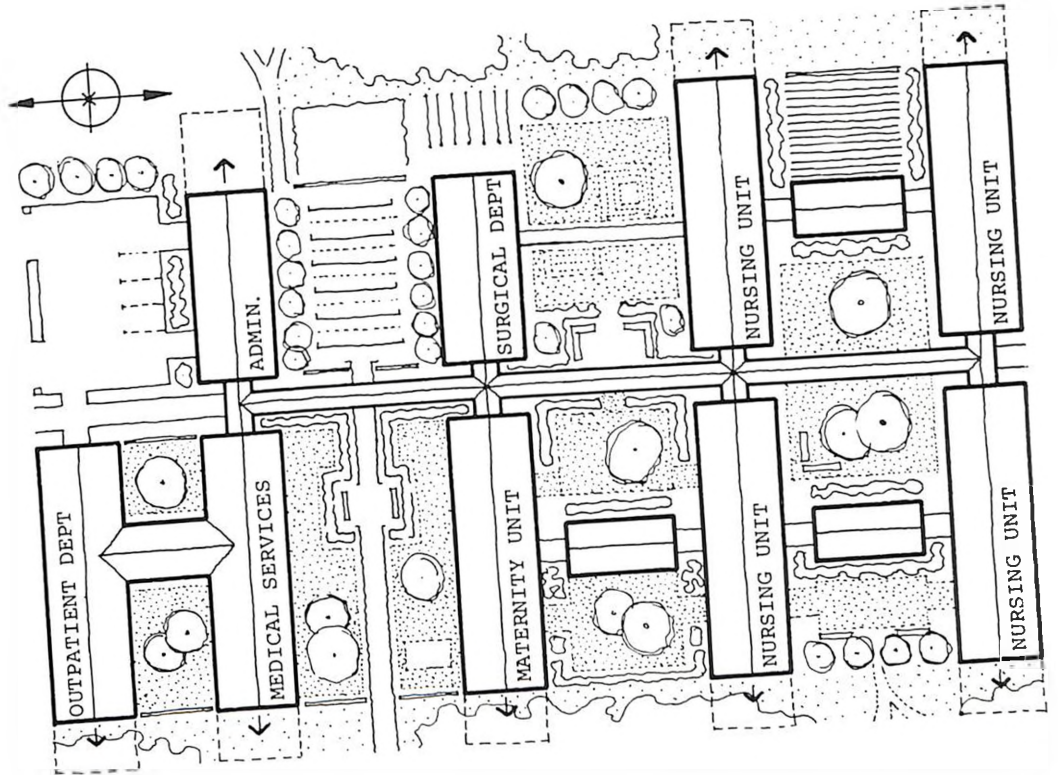

CATEGORY	EVALUATION	RATING		
Climate and orientation	Suitable for most climates except where high winds cause a tunnel effect between buildings. The spine should run north/south.			+1
Topographical adaptability	Can accommodate a slope along the spine with blocks following the contours. May cause drainage pockets between buildings.			+1
Circulation and planning	Circulation of people and services is efficient and economical. No separation between staff and patient movement but control is easy.			+2
Flexibility and extendibility	Similar blocks and their separation eases flexibility. Extension of buildings or addition of new ones is straight forward.			+2
Construction and economics	Repetitive nature helps standardized building methods and allows for phasing enabling maximum economy to be achieved.			+2
Architectural quality	Basic form lacks interest with no defined spaces but can be improved by variation or addition of secondary buildings and landscaping.			+1



the rectilinear plan

The most common form of rectilinear planning is the 'gridiron' which, in hospital design, is usually composed of separate rectangular blocks positioned in such a way as to form a chequer board of buildings and open space with circulation along the coordinates of the grid as shown in Figure 9.

FIGURE 9  
rectilinear plan

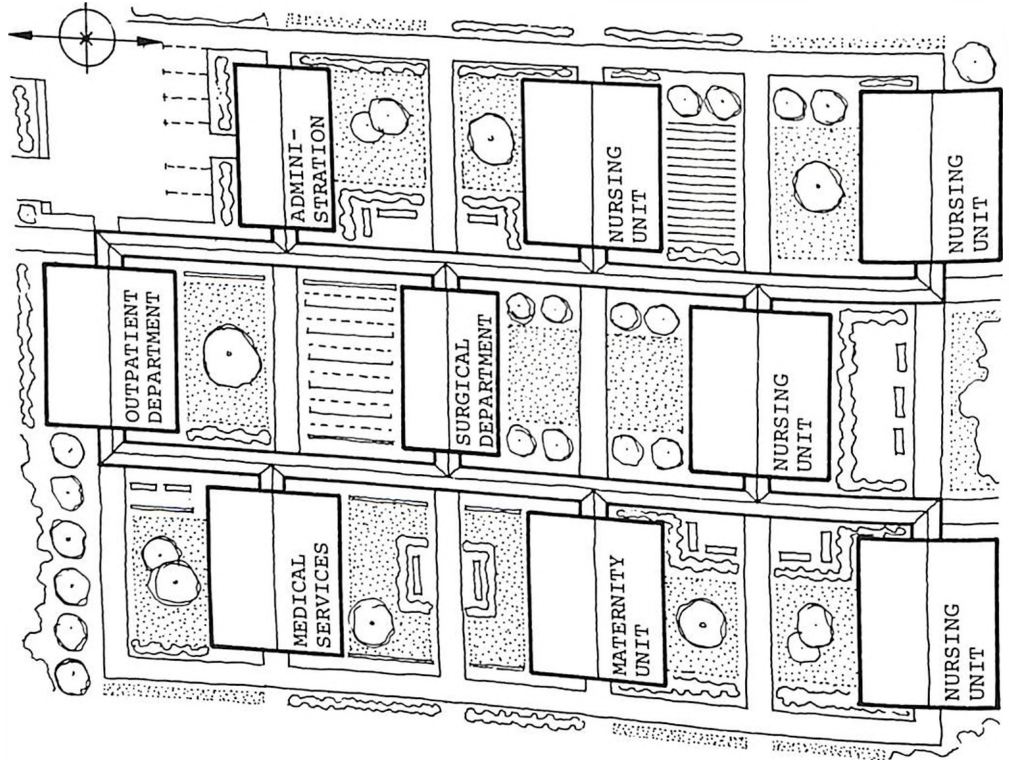

CATEGORY	EVALUATION	RATING		
Climate and orientation	Suitable for most climates though small number of rooms may face east/west. Gives well protected outside spaces.			+1
Topographical adaptability	Can accommodate moderate slopes in either direction by using ramps along the circulation routes.			+1
Circulation and planning	Circulation is flexible though extended. Routes can be covered partly by verandahs to the buildings. May be confusing.		0	
Flexibility and extendibility	Difficult to extend individual buildings unless pre-planned. Addition of new buildings is straight forward.		-1	
Construction and economics	Repetitive nature helps standardized building methods. Square blocks increase structural and wall costs, otherwise economical.			+1
Architectural quality	Creates pleasant courtyard spaces which can be landscaped differently according to their functions.			+2

the dispersed plan

Commonly called the 'pavilion' type the dispersed plan is found in many existing bush hospitals where generally there has been no shortage of space, and buildings have been added gradually over a number of years. The buildings are typically scattered over the site although Figure 10 shows a fairly tight arrangement.

FIGURE 10  
dispersed plan

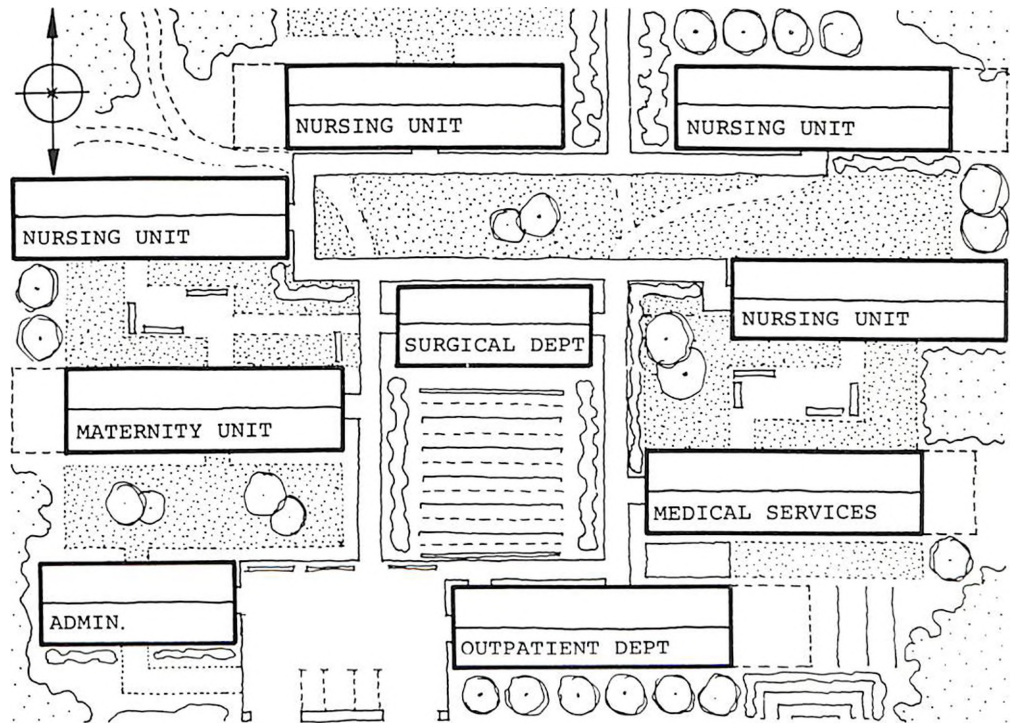

CATEGORY	EVALUATION	RATING		
Climate and orientation	Suitable for most climates except the dispersal of buildings can make circulation unpleasant in heavy rain or high wind.			+1
Topographical adaptability	Extremely adaptable to variations in contours. Blocks can be positioned to avoid obstacles and preserve existing vegetation.			+2
Circulation and planning	Circulation is extended and therefore difficult to protect. The relative positioning of the buildings can be ideal.		0	
Flexibility and extendibility	Similar blocks and separation eases flexibility. Extension of buildings or addition of new ones is straight forward.			+2
Construction and economics	Repetitive nature helps standardized building methods and allows for phasing enabling maximum economy to be achieved.			+2
Architectural quality	Poorly defined outside spaces give little character. Most successful on sites with good natural landscaping.		-1	

### 3.4 THE MASTER PLAN

A master plan of the site which will form the basis for current and future development, should now be drawn up at the scale 1:200. The plan should show all existing and proposed elements including:

- the property boundary
- topographical features such as hills, valleys, rivers, rock outcrops etc, with contour lines if possible
- existing buildings and structures
- existing vegetation including ground cover
- the compass points and direction of the prevailing winds throughout the year
- the position of existing service lines (water and sewers) and roads and footpaths crossing the site
- the direction of main population centres, public transport routes and access points into the site
- the position of proposed new buildings with areas for expansion
- the position of proposed service lines, septic tanks and water storage
- proposed roads and pedestrian routes
- proposed landscaping.

The master plan is an extremely important document and ought to be discussed as widely as possible and modified accordingly until it meets all the established requirements. It is impossible for such a plan to remain valid for a long period during which needs and the ability to meet those needs are changing. The master plan should therefore be revised periodically, especially at times when new buildings are to be added.



## CHAPTER FOUR - BUILDING DESIGN

introduction

The design of individual buildings is determined to a large extent by their internal functional requirements which in turn tend to be common to medical facilities generally. It has therefore been possible to give quite detailed plans as examples of possible design solutions. The plans shown in this chapter are, however, not intended as prototypes and should not be applied indiscriminately to live situations without taking into account the local conditions. It is recommended rather that the design criteria and methods outlined below be used to prepare specific designs to meet the needs of specific situations. Dimensions on the plans are shown in metric (m - metre, mm - millimetre), imperial equivalents are given in Appendix 6.

page 144

### 4.1 DESIGN METHOD

The first step in making a design for either a building or each room within a building is to establish the design criteria. These are the functional requirements which the building must satisfy in order to operate smoothly. The design criteria for each part of a hospital are analysed in the later sections of this chapter. To transform the functional requirements into a building design there are two particularly useful design 'tools' that can be used.

relationship diagram

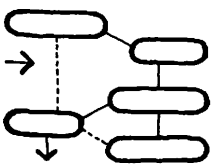

The first is the relationship diagram, sometimes called a 'flow' or 'circulation' diagram, which has already been introduced in the context of site planning in Chapter Three. It can equally well be used for building or room design. Each room within a building, or item within a room is given a diagrammatic shape preferably related to its approximate area or size. The shapes are then positioned relative to one another in accordance with the design criteria. The arrangement most nearly satisfying the criteria then forms the basis for making a floor plan. Sections in this chapter include relationship diagrams which can be modified to meet prevailing conditions.

building module

The second design tool is a device known as a building module which is a grid whose co-ordinate spacing relates to common dimensions used in design and construction. By positioning the building elements such as walls, doors and windows on the gridlines of the module, the design can be rationalized making the eventual construction simpler. The grid is usually composed of two orders, one being a multiple of the other (Figure 11).

FIGURE 11  
building module

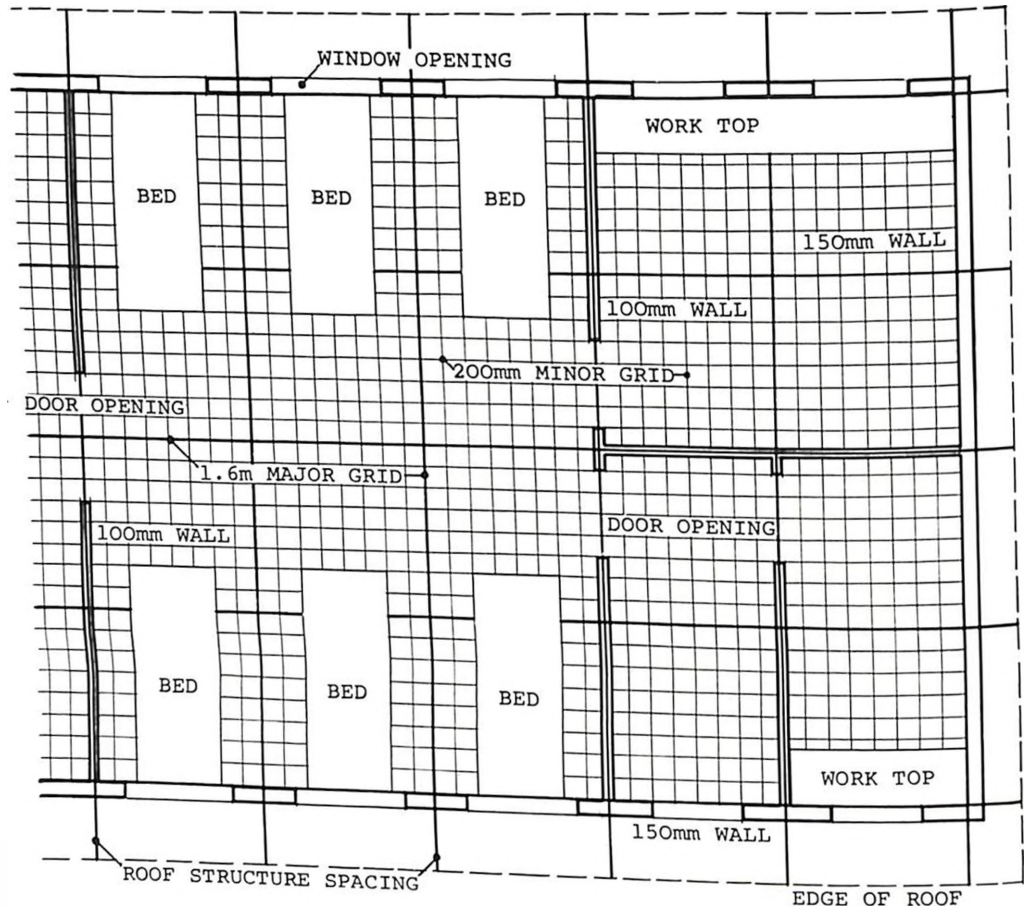

the major grid

The larger grid is related to the structure of the building and major planning dimensions such as the spacing of roof trusses and, in the case of hospitals, the spacing of beds. All main internal and external walls should fall on this grid to avoid complicating the structure which means that, besides being suitable for the structure, the grid itself or multiples thereof should allow for reasonable room sizes.

In this manual a co-ordinate spacing of 1.6 m has been chosen for the major grid. This figure is based on an optimum spacing for beds and is arrived at by balancing two conflicting factors. One is the need for adequate nursing space around each bed. The other is the natural tendency to accommodate as many beds in a ward as possible. It is also supported by observations made in a large number of rural hospitals in East Africa where the actual spacing varied from 1.2 to 1.8 m. The 1.6 m dimension is also suitable for the spacing of roof trusses and its first multiple of 3.2 m has been found to be a reasonable width for most smaller rooms such as offices and examination rooms. The further multiple of 6.4 m provides a versatile building width, capable of accommodating most medical functions, as well as giving an economic roof span.

the minor grid

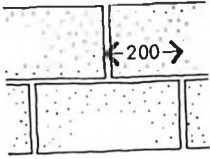

The minor grid is related to the size of common building components such as concrete blocks, ceiling boards and windows. By positioning internal partitions and door and window openings on this grid a maximum number of standard components can be used without cutting thus saving a considerable amount of money. Here a 200 mm minor grid has been chosen this being half the length, or overlap, of a standard metric concrete block. Its multiples also allow for a flexible range of choices for door and window widths and the positioning of partitions.

Again it should be remembered that, as with the relationship diagrams, the building module can be modified to meet the precise requirements of a particular job.

#### 4.2 OUTPATIENT DEPARTMENT AND MEDICAL SERVICES

outpatient department

The outpatient department provides the primary health care for patients in the immediate neighbourhood of the hospital and for patients referred to the hospital for special examination and treatment from health centres and dispensaries within its catchment area. The services provided include preventive care such as ante-natal and under-fives clinics, family planning clinics and T.B. clinics as well as curative care.

medical services

The medical services are composed of those functions such as the laboratory, X-ray unit and pharmacy which directly support or supply the medical departments. These services are here considered in conjunction with the outpatient department from where the majority of users will come but the important relationship with the in-patient and surgical departments should not be overlooked.

extent of services

The size and composition of services provided is determined primarily by the number of outpatients to be seen daily and to a lesser extent by the number of in-patients using the medical services. The size and design is also affected by the availability of staff.

staff

For example, if staff are in short supply, an X-ray technician who is quite possibly underemployed for part of the time can be of great assistance in the laboratory during its busy hours as long as these two units are situated next to one another. On the other hand, if staff is readily available, it may be reasonable to provide separate accommodation for say antenatal and family planning clinics whereas if the clinics are to be run by staff who normally perform other outpatient duties

they may as well take place in the rooms where the staff normally work. The general rule is that the more separate rooms a department has, the greater the number of staff that will be needed to run it.

volume of patients

ref 3



The flow of patients through an outpatient department is determined largely by the examination facilities and staffing. It is estimated that a medical assistant can reasonably see 20-30 patients in an hour or 160-240 in an eight hour day, through these numbers are often exceeded in practice. Of these approximately 40% are likely to require injections, 10% surgical dressings, 2% minor surgery and 4% will be referred to a medical officer for further examination. These figures will of course vary from place to place and should only be used as a rough guide.

The outpatient department involves a far greater circulation of people than any other part of the hospital with large numbers of patients passing through it daily many of whom will be unfamiliar with the buildings and procedures involved. It is vital that if confusion, disorder, time wasting and bad tempers are to be avoided, the design must be as clear and direct as possible.

FIGURE 12  
outpatient relationship  
diagram

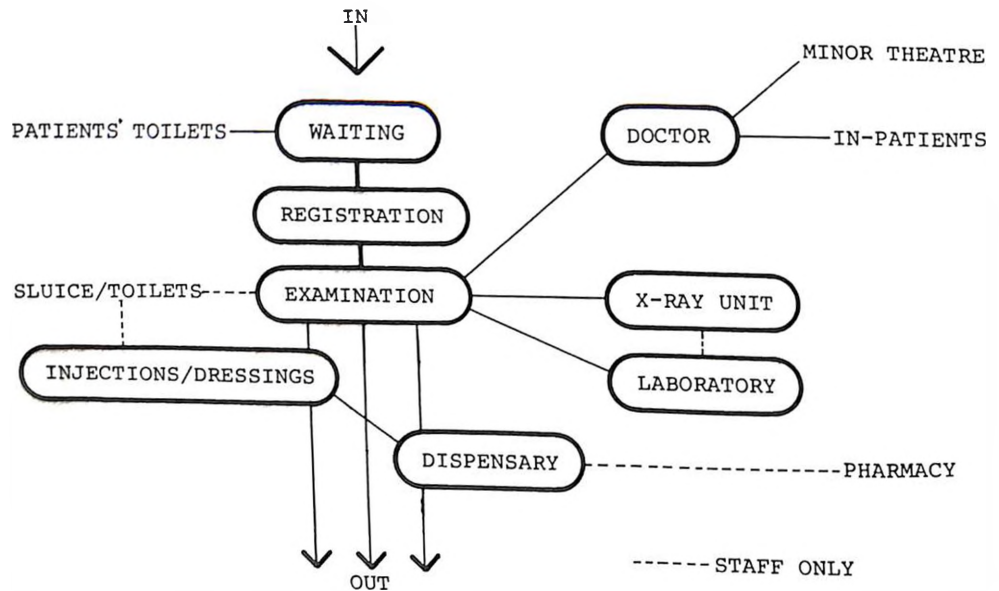

patient flow



The movement of patients through the department depends upon the system adopted but generally it will follow the sequence listed below and shown graphically in Figure 12.

- the patients arrive and need a waiting area
- some form of sorting, eg. males and females, adults and children takes place
- some form of registration takes place

- the patient is examined
- he may be sent for further examination to other medical personnel or to the laboratory or X-ray unit
- he then returns to the examiner *why? how?*
- the patient may be referred for some form of treatment such as dressing or injection
- he collects medicine from the dispensary
- leaves the unit.

In the following pages the various functions of the outpatients and medical services are dealt with individually. The design of the rooms is as important for the successful functioning of the staff as the planning of the whole department is for the ease of movement of the patients. The comments and hints are offered as an aid to avoid the most common mistakes and as guidelines on principles and details which have been found to be useful.

### Sorting and Registration

A large covered waiting area is the first essential space. It can be simply constructed, consisting mainly of a roof with lightweight walls where necessary for protection against the sun or wind. There should be fixed benches to sit on and the walls should be provided with ample pinboards and possibly a chalk board for use in health education.

Large numbers of people may arrive early or in batches by bus for instance, and often patients who have finished their treatment will be waiting for friends or buses to arrive. For these reasons the capacity of the waiting area should not be less than 20% of the total daily attendance. There should be access down wind, *\* to drinking water and to toilets* which can be in the form of pit latrines and which, if properly built and kept in good order can act as an incentive for the patients to copy them at home.

Registration systems vary but generally the office should be situated with easy access to, and a good view of, the waiting area so that the person in charge can help to keep order. A prominently displayed colour coded plan of the whole outpatient department is a great help in explaining to the patients where to go. The

waiting space

$$\frac{20}{100} \times 600 = 120$$

registration office



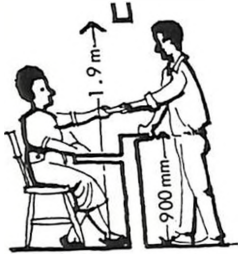

FIGURE 13  
office

office should be able to accommodate two desks and have a generous amount of well spaced shelving to carry box files containing patients' records. The hatch through which the patients are served should not be too small. There is no reason why either the patients or the staff should bend or stretch in order to communicate (Figure 13).

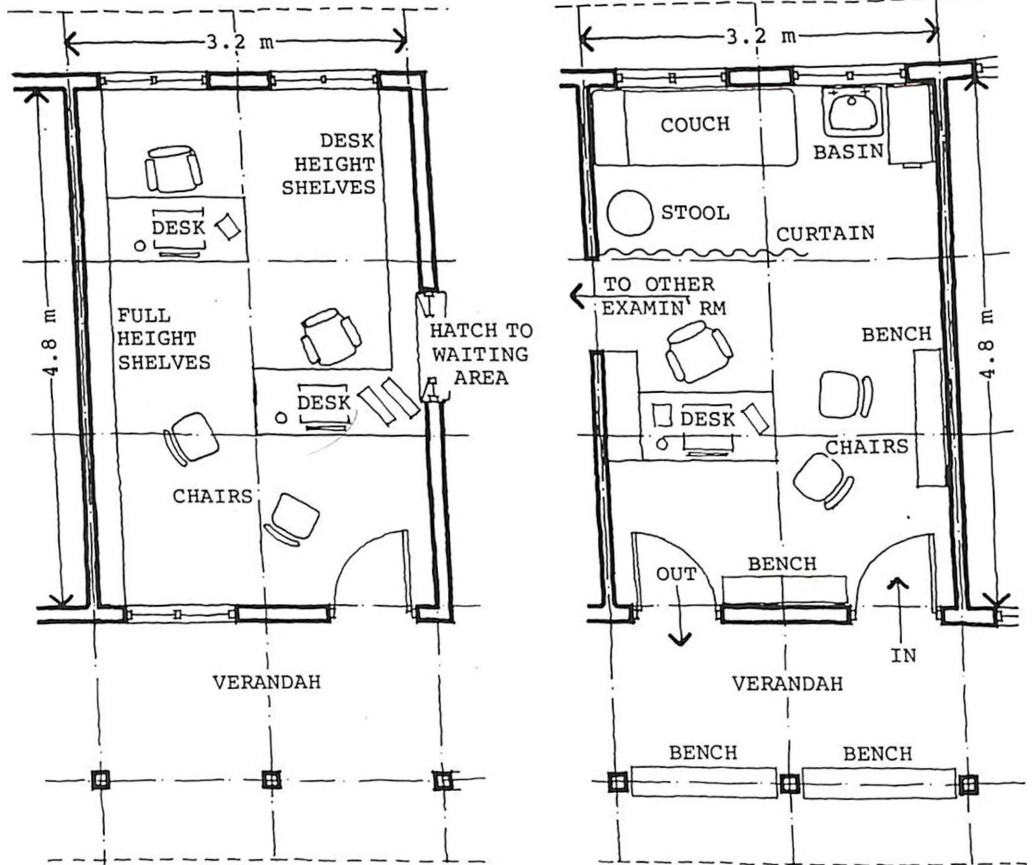

FIGURE 14 →  
examination room

### Examination Room

Whoever examines the patients when they arrive, whether doctor, medical assistant, rural medical aid or midwife, a room well lit by natural light, well ventilated and as well insulated against noise as possible, is needed. There should be separate ways in and out preferably at the same end of the room so that the examiner has his own territory at the other end. The doors should open into the room, not out into the waiting crowd, and a connecting door between adjacent rooms is useful for allowing consultation between colleagues (Figure 14). If training of medical assistants is undertaken in the hospital, it is useful to provide a room adjacent to the examination room with three separate cubicles in which the trainee can carry out examinations.



furniture

The room must have enough space for a desk and chair, a small book case for hand books, a lockable cupboard, a hand wash basin, a chair for the patient and a bench for accompanying children or other relatives. To allow children to come with their mother is important; they become familiar with the hospital and otherwise their crying outside the door of the examination room is a distraction. There should be an examination couch capable of being screened from the rest of the room. It can be argued that there is little need for an examination couch with only 2-3 minutes available per patient, but this is only an average time and many patients must be examined lying down.

### Laboratory

The size of the laboratory and its arrangement and equipment will vary according to the size of the hospital, the number of outpatients and the staff available. At least two rooms are necessary however for the laboratory proper, one for the examination of unclean samples, stools and urine, and one for haematology and biochemical work. In a rural hospital both in and outpatients will be served and provision should ideally be made for separate entrances for each category of patient (Figure 15).

FIGURE 15  
laboratory

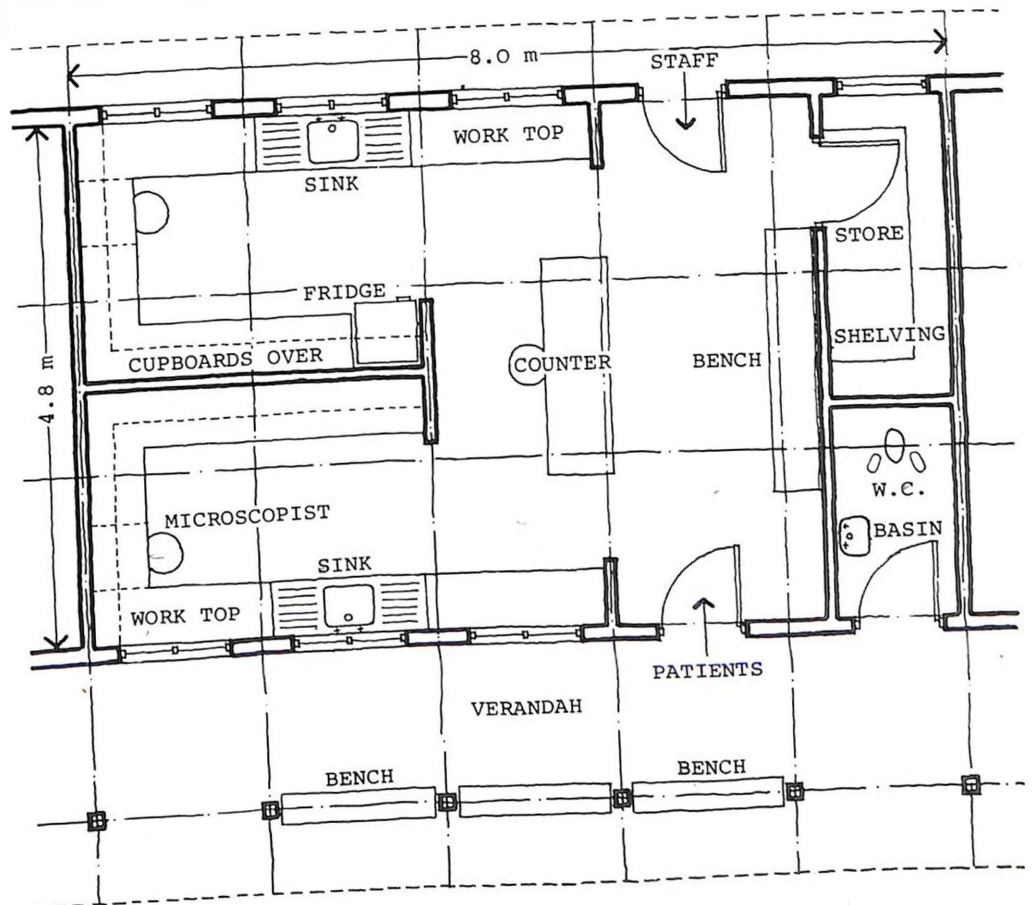

## sample taking



A great number of people will visit the laboratory and all of them will have to deliver samples of either blood or excreta. An ample space, separated from the laboratory by a counter, is needed for taking blood samples. It is usually expedient to line a number of patients up at a time and, after having taken the necessary details for the laboratory register, take samples in an 'assembly line' fashion. A fixed bench along one wall is most useful for this procedure and it can also be used as a couch for people who feel faint after giving blood. An arrangement of pigeon holes for staff from other departments to leave samples and later pick up the results can also be placed in this area.

Since stool and urine samples will be needed from a large number of people, at least one w.c. cubicle near, but outside, the laboratory will be needed. The 'eastern type' of lavatory is most useful for this purpose as many people find it difficult to produce a stool sample into a small container on a 'western type' lavatory.

## colorimetric tests

Much laboratory work depends upon colorimetric tests which require daylight for reliable and easy reading. It is therefore wise to place work tops near to the windows using the darker areas for storing the samples. If however electrically operated colorimetric apparatus is to be used, then the reading is easier in subdued light.

## microscopy



A common mistake is to place a microscope in such a way that the microscopist faces the window which provides the source of illumination. The glare from the window in his eyes when concentrating on a relatively dark field is, however, a common cause of tiredness and headache. The illumination is just as good if the microscope is placed sideways near the window with the microscopist facing a relatively dark wall.

Generally, laboratory spaces should have as much impervious work top area as possible placed 900 mm above the floor for comfortable standing work, with cupboards underneath and shelves above. Frequent clear spaces are needed under the work tops as knee spaces where stools are to be used. Each section will need a sink and the 'clean' area a refrigerator.

## X-ray Unit

The design of the X-ray unit is a specialized matter requiring that a number of safety precautions are taken into account. The extent of the precautions depends

upon the type and size of machine and therefore the advice of the manufacturer should be sought. Besides the machine, the size of the room affects the thickness of the protective walls in that the shorter the distance between the machine and the walls, the thicker the walls must be. Government safety regulations must also be observed and these should be obtained, usually from the government radiologist, at an early stage.

The X-ray room should be able to accommodate the machine itself with sufficient space around to manoeuvre a stretcher trolley easily. In addition two small changing rooms are needed and space for a desk, a work top and a small book-shelf for reference books. If exposed films are to be stored in this room a steel filing cabinet 2.1 m high and 900 mm wide will hold about 3000 films and is ideal for the purpose. The control console should be behind a heavy screen for the protection of the technician. The door must be wide enough (1.1 m) for the machine to be taken in and out for repair or replacement (Figure 16).

FIGURE 16  
x-ray unit

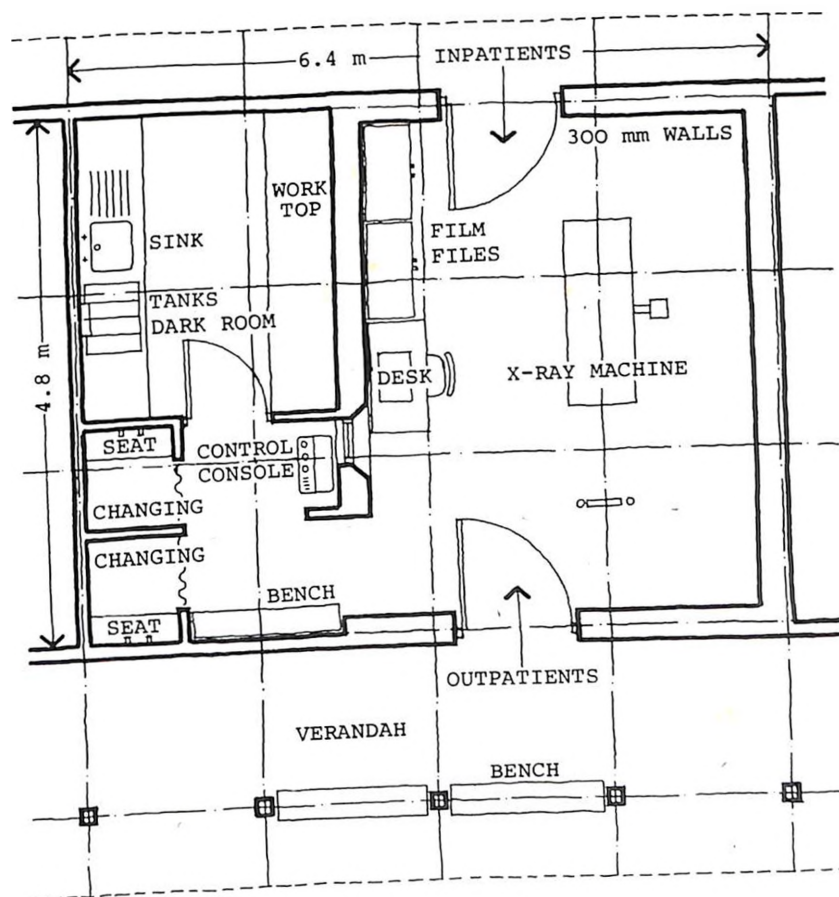

darkroom

The darkroom should be large enough to accommodate the developing, rinsing and fixing tanks and a large sink and work top area. It can be entered through

a light proof lobby but in a small unit with only one technician this is not essential. Running water is essential and a drained floor useful. It is common to use the darkroom for the storage of new films and chemicals, and well ventilated cupboards or shelves should be provided, divided to hold stocks of different sizes. Light proof drawers should be used for common sizes in day to day use. The work top should be ample for loading even the largest cassettes, with compartments below for storing empty ones. Rails for drying processed film are best placed over the sink and sturdy hooks for storing film frames are easily made out of steel piping cemented into the wall. A viewing screen should be on the wall adjacent to the developing tanks.

### Treatment Rooms

The demands for treatment facilities vary a great deal depending on the area served. In urban and semi-urban districts with some industry and road traffic, for example, the need for treatment of minor injuries is greater than in the rural setting, while in some rural areas eye diseases, for example, account for a large proportion of outpatient work. If factors of this kind are known, they should be taken into account.

treatment groups

Generally outpatients can be divided into two main groups, those who need injections and those in need of some form of dressing, application of ointments or lotions, syringing of ears etc. A third, but much smaller, group will need minor surgical procedures. This implies that a minimum of three rooms are needed for outpatient treatment.

room design

The dressings and injection rooms can be the same size and have some design features in common. Bottlenecks often occur in the treatment rooms because the procedures involving preparation of injections and dressings and the cleaning and sterilizing of instruments are time consuming. The time spent can be minimized if the rooms are in effect divided into two zones, one in which the staff can make notes and prepare their instruments undisturbed and one in which the patients line up in batches to receive their treatment. As with the examination rooms the treatment rooms should have separate ways in and out.

work area

In the staff zone, ample cupboards, work tops and shelves should be within easy reach so that unnecessary movements are kept to a minimum. A sink and electric or gas cooking plate are essential for cleaning and sterilizing instruments. It is



also useful if, by the provision of interconnecting doors, utensils can be collected on a trolley for cleaning in a separate sluice room.

In the dressings room, a two tier bench fixed against the wall in the patients' area is indispensable. Patients who need dressings etc on the upper part of the body sit on the lower bench, while dressings and attention to ailments on the legs and feet are much easier for staff when the patients sit on the upper bench. The staff will require stools or ideally typist type chairs with castors, to sit on while they attend to the patients (Figure 17).

dressings



FIGURE 17  
dressings room

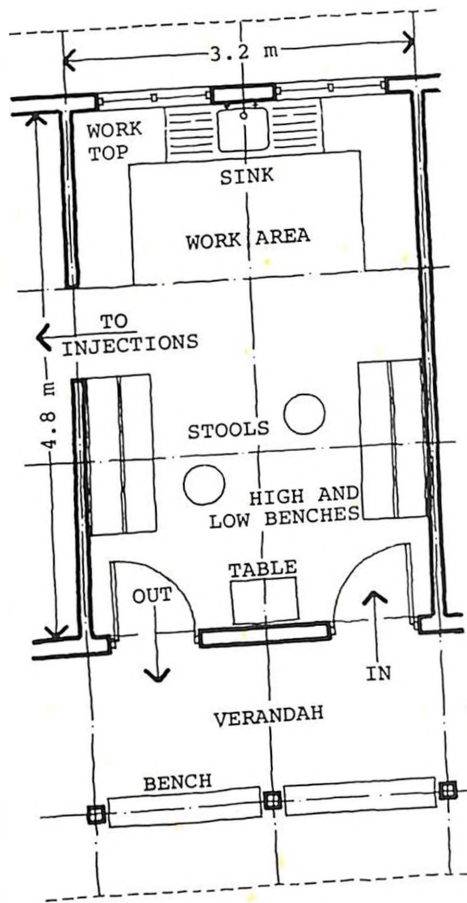
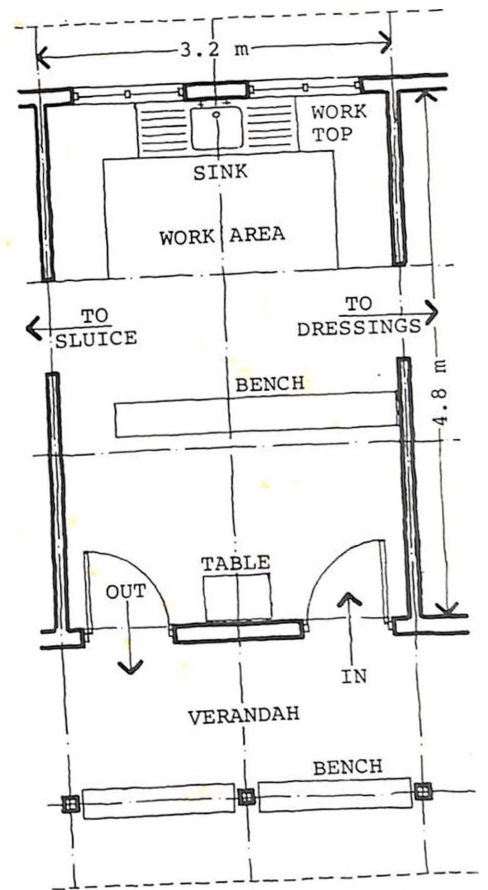

FIGURE 18 →  
injections room



injections

In the injection room a free standing bench forming a separation between staff and patient areas is ideal for patients to sit on while receiving injections, it allows the discreet uncovering of the part of the buttock usually chosen for injections (Figure 18).

minor theatre

The minor or 'septic' theatre needed for minor surgical procedures such as suturing of small wounds, opening of abscesses and application of plasters may be situated in the outpatient department or alternatively, in the theatre block where it can

benefit from shared equipment and sterilizing facilities. The decision is affected by the anticipated relative usage by outpatients and inpatients but in this manual its design is dealt with under the surgical department.

Drugstore, Pharmacy and Dispensary

The facilities for storing, preparation and distribution of drugs can be situated together in the best position to serve the whole hospital. Alternatively the drugstore and pharmacy can be placed together serving all departments with drugs as well as a separate dispensary in the outpatient department. The first alternative is more compact and therefore efficient, the disadvantage being that as the majority of users of the dispensary are outpatients it involves situating the whole unit in the outpatient department which is not ideal for the drugstore and pharmacy.

FIGURE 19  
drugstore and pharmacy

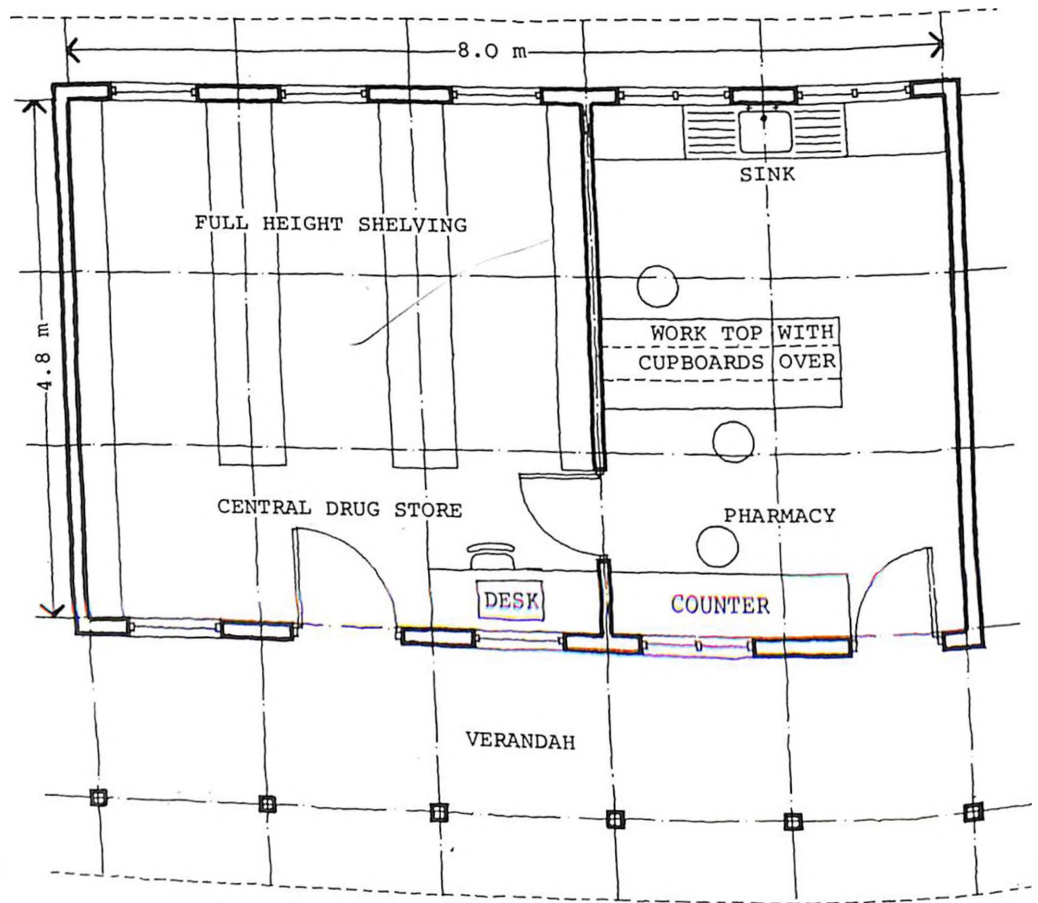

drugstore

The drugstore should obviously be secure and visually controllable during working hours. The main requirement is for plenty of floor to ceiling shelving with the shelves spaced at varying heights so that while tall bottles can be stored smaller items need not be piled on top of one another to avoid wasting space. The store



keeper will need a desk from which he can issue items to staff members from different departments, or alternatively all items can be issued via the pharmacy.

pharmacy

The pharmacy must be well lit, have as much work top area and cupboard space as possible and at least one sink. Drugs will be distributed from the pharmacy to all other departments including the outpatient dispensary, out-lying and mobile units. It is therefore important that vehicular access is provided (Figure 19).

dispensary

The outpatient dispensary requires a small work area with work tops, a cupboard and a sink for batching the drugs which arrive in bulk from the pharmacy. At the other end of the room a counter upon which the most commonly prescribed drugs can be set out should be situated next to a hatch through which the patients are served (Figure 20).

FIGURE 20  
outpatient dispensary

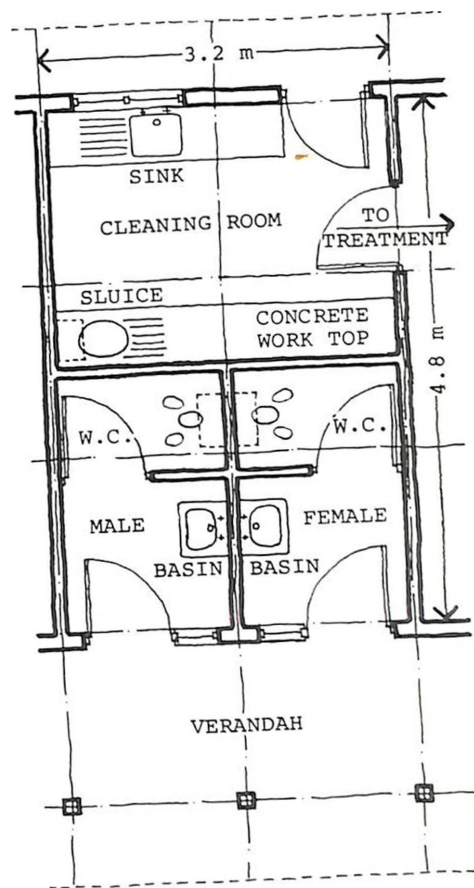
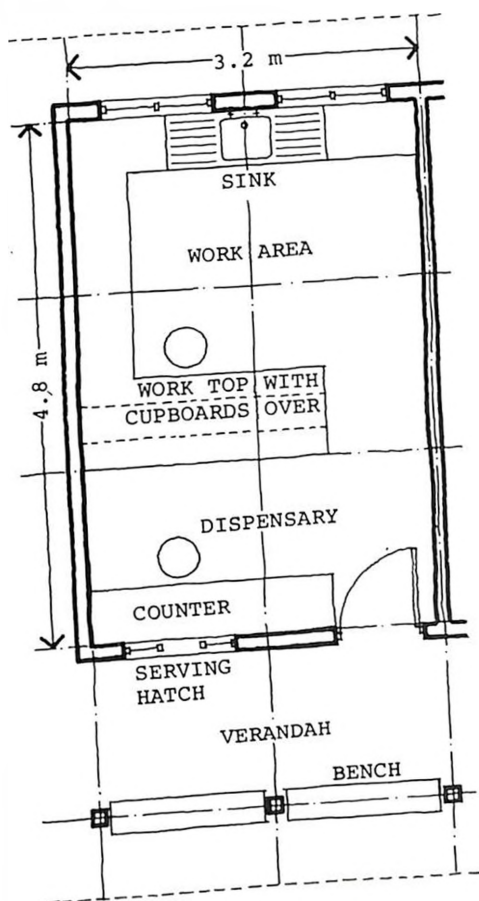

FIGURE 21 →  
sluce and toilets

### Sanitary Facilities

Besides the toilet provision already mentioned in connection with the waiting area and laboratory, two further facilities are required for the outpatient department as

a whole. The first is for two toilets for male and female patients, each consisting of a w.c. and hand basin. These can be associated with a cleaners room containing a sink and w.c. type sluice set in concrete work tops, with provision for storing cleaning materials (Figure 21). Secondly, male and female staff changing facilities are required with ample locker space and a w.c. and basin in each. Finally there should be some provision in the form of a bath or shower for patients who need to be bathed completely.

### Outpatient Department Planning

A plan for the outpatient department can now be made by combining the elements needed in such a way as to satisfy the requirements of the relationship diagram shown in Figure 12. It is impossible to generalize about a design solution, there being so many variables as to what should be included, as well as differences in local conditions. Even for identical circumstances several alternatives are possible, nevertheless, and in order to give some idea of the possibilities three examples are illustrated here.

the basic plan

The first example (Figure 22) shows what could be considered the simplest workable unit for an outpatient department which might also be suitable for the nucleus of a small health centre. It consists of a single building capable of dealing with approximately 160-240 patients per day requiring five trained staff members to operate. The rooms are arranged in such a way that for a smaller number of patients the staff could be reduced by sharing activities.

small capacity O.P.D.

The second example (Figure 23) is designed to deal with the same number of patients but with improved facilities, notably the addition of an X-ray unit and increased laboratory size. The design consists of two blocks connected by a secondary waiting area to form an H-shaped plan. This provides an improved internal environment and better control over the movement of patients. The plan provides for patients to enter and leave at the same end of the building and to this extent it deviates from the diagrammatic relationship diagram.

medium capacity O.P.D.

The third example (Figure 24) has twice the capacity and might be considered suitable for a typical rural hospital of around 100 beds and handling about 400 outpatients daily. For a unit of this size it is no longer feasible to think in terms of a single block as this would be too long. The patients enter and leave at opposite ends of the building but this could easily be reversed to give a similar situation

FIGURE 22  
basic outpatient department

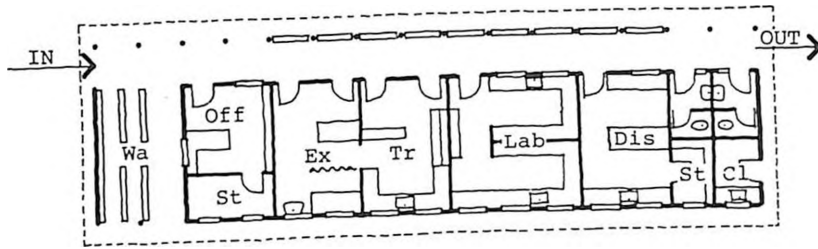
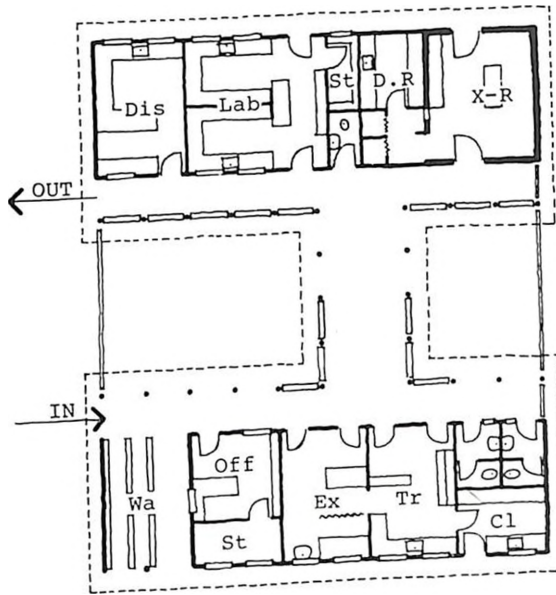

FIGURE 23  
small capacity outpatient department



LEGEND

- Wa - WAITING
- Off - OFFICE
- Ex - EXAMINATION
- Tr - TREATMENT
- Dr - DRESSINGS
- Inj - INJECTIONS
- X-R - X-RAY UNIT
- D.R.- DARK ROOM
- Lab - LABORATORY
- D.S.- DRUG STORE
- Ph - PHARMACY
- Dis - DISPENSARY
- Cl - CLEANER'S RM.
- Ch - CHANGING RM.
- St - STORE

FIGURE 24  
medium capacity outpatient department

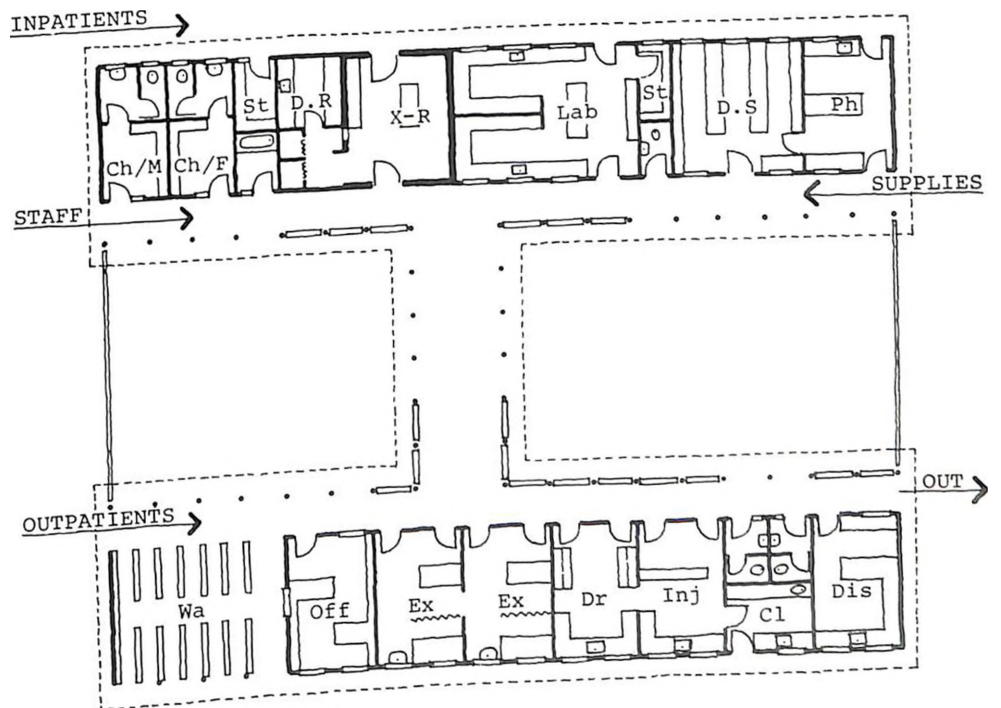

as in Figure 23. In this example the outpatient activities and the medical services are clearly expressed as separate buildings whose organization closely resembles the basic relationship diagrams in Chapter Three. Outpatients visiting the laboratory or X-ray unit in the medical services block always return to the outpatient side. Inpatients on the other hand use the medical services from the opposite side thus remaining segregated from the outpatients. As with the other plans, it is assumed that the doctor's office, to which some patients will be referred, is located separately but fairly close by.

design features

All these examples satisfy the criteria set out earlier in this section and also incorporate some additional design features. From an economy point of view, a standard building module (1.6 m and 200 mm) is used throughout with a uniform structural span (6.4 m). The buildings are simple rectangular blocks suitable for most types of materials and construction methods. The sanitary fittings are all placed in such a way as to minimize the length of water supply and drainage runs.

flexibility

An element of flexibility is maintained by spanning the roof trusses from the front to the back walls, which means that any of the internal walls could be knocked down or modified at some future date without affecting the stability of the building. All the plans are open ended allowing for easy future extension, should that be necessary. The blocks are positioned so that the main faces of the buildings can always face north and south.

#### 4.3 ADMINISTRATIVE OFFICES

The extent of office accommodation required will depend upon the staffing of the unit and its role within the regional health framework. In this respect the Ministry of Health or other governing body should be consulted as to their general requirements. Besides this there are a number of offices needed which can be determined by the size of the unit itself.

number of offices

In a typical rural hospital, offices will normally be required for senior medical staff: the medical officer, his assistant and the matron. Although the medical officer will be in overall charge of the hospital, he should be relieved of much of the administrative burden by an administrator who will be responsible for keeping the accounts and central filing and coping with day to day matters. He may well have his own assistant requiring a small office and a large amount of lockable storage space for hospital files and stationery supplies. In addition there may be a

separate admissions office and the previously mentioned registration office in the outpatient department. If trainee staff are employed, it is important not to neglect their requirements for office space which they will need as a base and for study purposes.

location

Administrative offices are often found in the outpatient department but the generally high level of noise and activity make this situation unsatisfactory. It is far better to group all the offices together in a small block some distance away but convenient to the outpatients. The design of offices is a simple matter requiring only that they be well lit, have plenty of shelf space and be as well insulated against noise transmission as possible. An area of about 15 m<sup>2</sup> is generous for senior staff members and at the same time adequate for two junior members sharing.

### Doctor's Office

The doctor's work in a rural hospital includes a variety of activities. Besides the clinical work with patients there is teaching, administration, public health and regular visits to outlying dispensaries. It is therefore difficult to determine an ideal location for the doctor's office. One possibility is to have two separate units with an examination room in the outpatient department and an office in the administration block. Generally this is not a good solution. In practice the doctor will tend to use one of the two for most of his work or he will be constantly moving between them to the confusion of any one wanting to find him. It is therefore proposed that the doctor's office be situated along with those of the other senior members of staff in the administration building.

office design

The doctor's office should be spacious enough to accommodate an administrative area containing a desk, ample book cases with glass doors for the hospital library (the glass doors are no luxury in often dusty rural areas) and a conference table with chairs enough for small staff meetings. Part of the room should be curtained off and have an examination couch and a trolley for instruments. A small cloak-room with a w.c. and wash basin is most useful (Figure 25).

examination room

Ideally a separate room next to the office should be provided for gynaecological examinations and minor procedures requiring the undressing of the patient. It is important that there is separate access to this room so that an assisting nurse can take patients in and out and prepare for examinations while the doctor carries on with his work in his own office.

FIGURE 25  
doctor's office

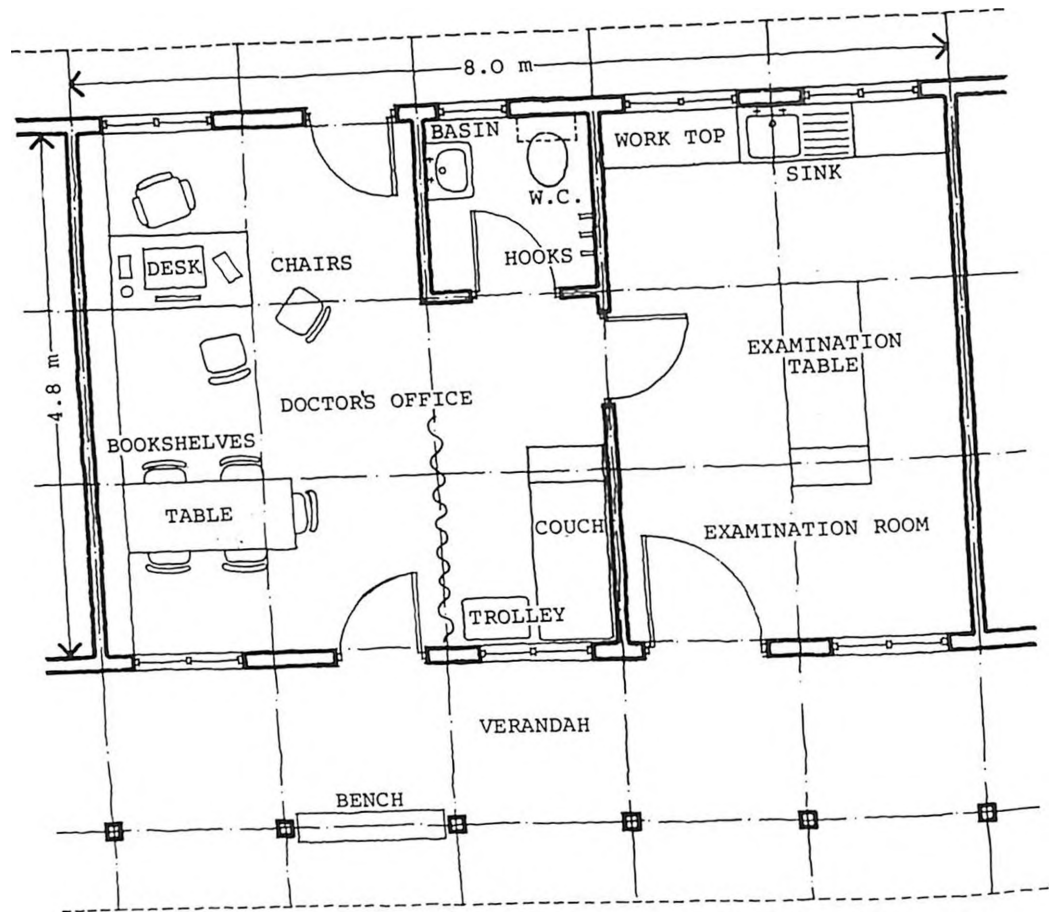

#### 4.4 SURGICAL DEPARTMENT

The surgical facilities provided should be able to cope with most surgical and obstetrical emergencies and the routine procedures commonly required by people living within the neighbourhood of the hospital. The range of surgical activity may be extended by the availability of visiting specialists or narrowed by the proximity of a regional hospital to which patients can be easily referred. Nevertheless, if the facilities can accommodate routine work, then the range or procedures beyond that will depend more upon the skill of the doctor and the surgical equipment at his disposal than upon the buildings themselves.

composition

There are three types of activity which call for the use of surgical methods: aseptic surgery, septic or minor surgery and child delivery. They each require rooms that share some common facilities such as a sterilizing room and common equipment such as instruments and anaesthetic apparatus and they require a similar quality of building. The rooms are sometimes used in conjunction with one another as for example when complications arise in the delivery room and the patient is transferred to the



theatre for delivery by caesarean section. From these points of view it is convenient to group all three rooms together although there are some further factors which argue for their dispersal. The main one is that each room serves a different part of the hospital, the main theatre serving the general or surgical wards, the delivery room serving the maternity department and the minor theatre serving predominantly the outpatients. Depending on the overall plan of the hospital, the work load and the availability of staff, it may not be feasible to serve these different departments at one central location.

functional relationships

In situations where funds and staff are scarce and where the workload is modest, the surgical department may only consist of a block containing an operating theatre, sluice room and sterilizing room. If, however, all the surgical elements and ancillary rooms for a larger hospital are grouped together, a fairly complex architectural problem is created. The diagram in Figure 26 shows the relationship of the elements to one another and to the rest of the hospital.

FIGURE 26  
surgical department  
relationship diagram

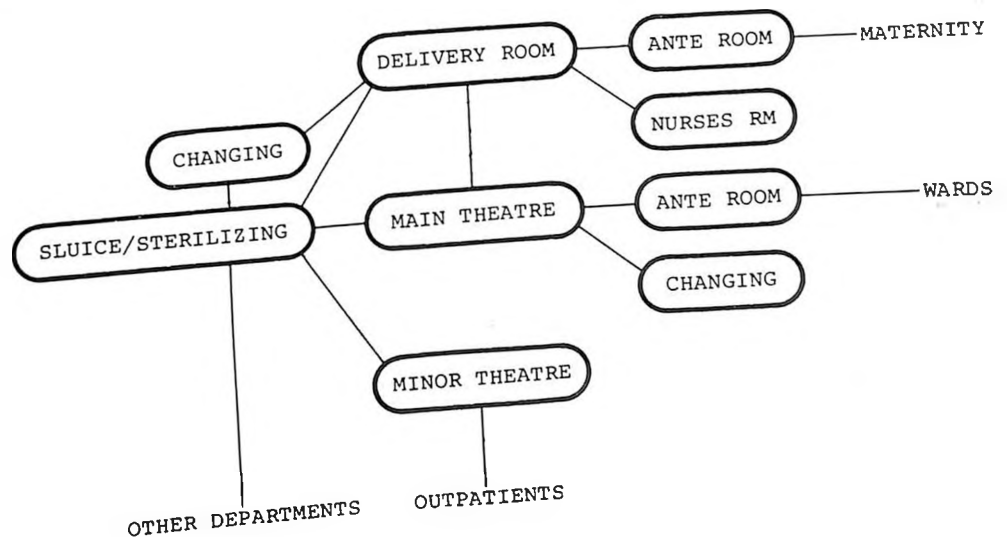

In the following, the various facilities in the surgical department, their functions and relevant design criteria are dealt with individually, always bearing in mind that functionally each unit is closely linked to the others.

### The Operating Theatre

For the layman a certain amount of mystique is often attached to an operating theatre and the concepts of sterility and asepsis. It is important to point out therefore that the theatre is simply a room where surgical operations take place. Theatre work is based upon routine and drill designed to facilitate the various activities,

preserve the sterility of the surgical field, instruments and surgical team and to prevent mistakes. The architectural design should be compatible with this (Figure 27).

FIGURE 27  
operating theatre

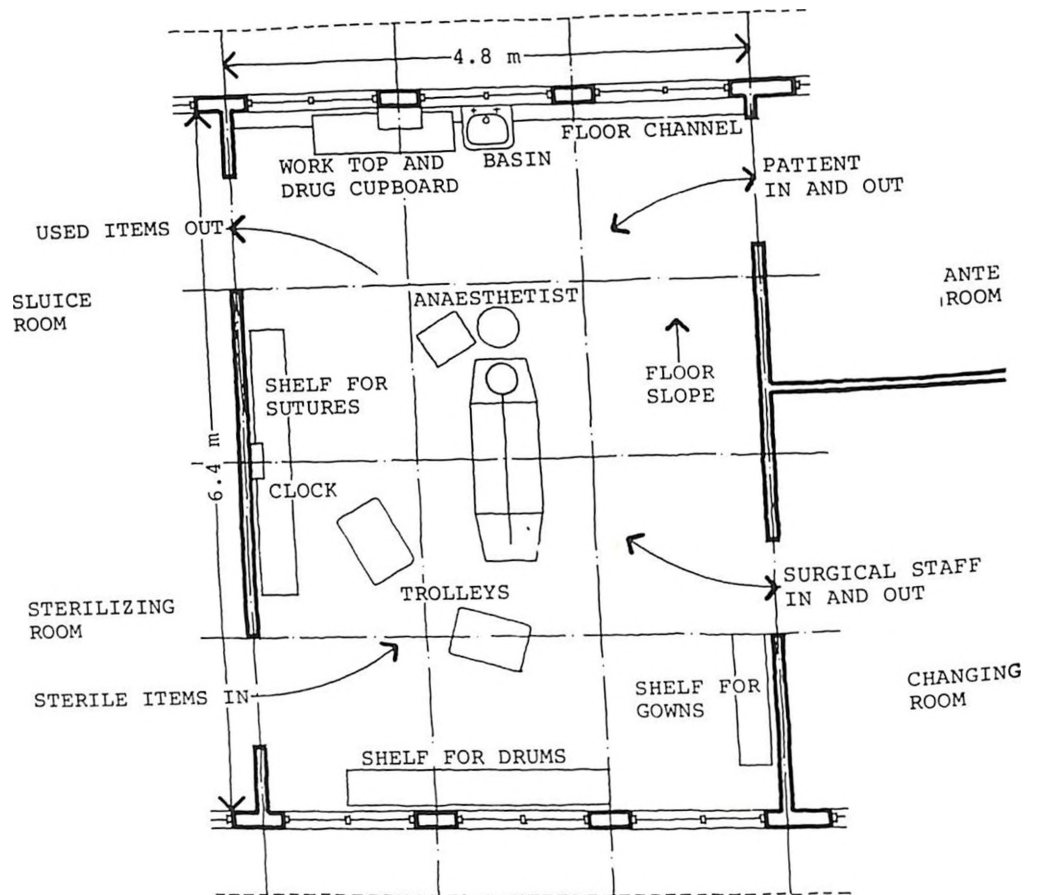

surgical staff

The number of surgical staff should be kept to a minimum consisting normally of the surgeon, his assistant and the nurse in charge of the instruments. The anaesthetist works at the head end of the operating table and may himself have an assistant or trainee. Also 'on the floor' is a further nurse or theatre assistant whose job is to clear away used items and count swabs etc. The anaesthetist, his assistant and the theatre assistant are not 'sterile' and an important part of the drill is to ensure that their work and movements do not compromise the sterility of the operating team and its equipment.

sterile and unsterile zones

To ensure this the theatre is divided into a sterile zone at the foot end of the operating table and an unsterile zone at the head end. This demarcation is not of course precise but rather an indication of the kind of activities permitted in the different parts of the room. It concerns the comings and goings from the ancillary rooms quite as much as the activities within the theatre itself.

In the unsterile zone the anaesthetist and the theatre assistant can move freely without interfering with the operation. The patient's entrance and access to the sluice room should be at this end of the theatre to prevent unsterile items and personnel passing through the sterile zone. The surgeon and theatre nurse operate in the sterile zone and access from the sterilizing room and from the staff changing room and scrub-up should be located in this half of the theatre.

other design principles

Besides adhering to the principle of maintaining sterile and unsterile zones there are three basic requirements which must be fulfilled:

- cleanliness
- adequate space
- good quality lighting and ventilation.

cleanliness

It goes without saying that an operating theatre must be as clean as possible which means that it must be easy to keep clean. Small amounts of dirt brought in from outside on shoes and trolley wheels are less of a hazard than generally believed. The same is true of dust blown in through windows. The major source of infection is generated within the theatre itself. Pus and excreta spilled on the floor must be effectively washed away between each operation.

The theatre must contain as few corners, niches and crevices as possible for these are the places where contaminated deposits form breeding grounds for micro organisms. All surfaces should be smooth, crack free and impervious.

theatre floor

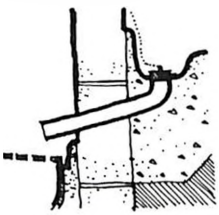

walls and ceiling

The floor should ideally have a terazzo surface but a smooth concrete finish is perfectly acceptable. To ease washing down, the floor should slope (1:100) towards an open channel along the foot of the wall at the unsterile end of the theatre. The channel should have a plugged outlet leading directly outside to an open gully. This arrangement is far superior to the usual drain hole covered with a grille of which the main function is to hide from view the undesirable deposits underneath it. An ideal arrangement for actually washing the floor is to fit a sparge pipe to the wall at the sterile end about 150 mm above the floor which can flood the entire floor by simply turning on a tap.

Smooth walls do not necessarily imply the use of expensive imported materials such as ceramic tiles. In fact a poorly executed tiled wall will have more cracks and crevices than a far cheaper sand and cement backwash application painted with one coat of emulsion and two coats of eggshell gloss. The roof construction should

be closed off by a ceiling of say softboard or expanded polystyrene with a similar painted finish.

#### details

Architectural details such as mouldings, architraves and window boards should be eliminated where possible and the number of doors kept to a minimum. Every time a door is opened and closed dust from the floor is whirled up into the room. Also door frames and ironmongery (handles, locks, hinges etc) may harbour more germs than the door is supposed to exclude. In this respect, no doors are needed between the anteroom or changing room and the theatre and they are only required between the sluice and sterilizing rooms and the theatre if these rooms will be in use when the theatre is not.

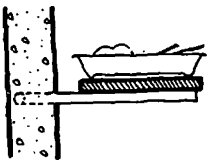

The same principle applies to any kind of fixed furniture which should be avoided in favour of mobile trolleys. Where shelves are needed they are best set away from the wall by 50 mm to ease cleaning, and resting on simple metal rods built into the wall so that they can be lifted off for thorough cleaning or repainting.

#### theatre size

The second basic requirement is for adequate space. A room of approximately 5 m by 6.5 m will provide sufficient space for all normal theatre activities. In places where a heavy case load is expected, it is far better to build a second theatre than to make the first one larger. Extra space in the theatre will only become the repository for all sorts of seldom used equipment.

There must be space enough for the staff to move freely within their zones without brushing up against walls, equipment or each other. Additional space is needed for manoeuvring and parking the patient's stretcher next to the operating table and for parking a number of trolleys carrying sterile supplies without congestion.

#### shelves

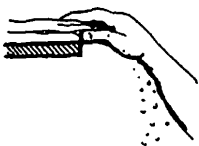

Several shelves are needed particularly for sterilized drums, for sutures and for gowns, caps and gloves. Shelves for gloves must be at least 1.2 m high so that, after scrubbing up, the hands can always be kept higher than the elbows ensuring that water will run back up the arms rather than down over the clean hands and on to sterile items. All shelves should, in any case, be 1.0 m high so that trolleys can be parked beneath them.

#### anaesthetic equipment

The anaesthetist's equipment and drugs are usually laid out on a trolley. He also needs a small lockable cupboard and a work top area within easy reach of his place next to the patient's head. A sink in the same area will be a great help to the

anaesthetist for cleaning his instruments. The tap on the sink can be used to operate an induced suction device where a more expensive electric suction pump is not available.

other items

Other miscellaneous items may be required including a clock, a screen for viewing X-ray films and one or two drip stands. The latter are best replaced by long wire hooks suspended from the ceiling near the head of the table thus avoiding the clutter of stands. Electrical outlets where provided should be 1.5 m above the floor to minimize the danger of ignition of explosive gases used in anaesthesia.

electric lighting

The third basic requirement is for good quality lighting and ventilation. Where electricity is available, the ideal is a scialytic operating lamp fixed to the ceiling and movable in all directions. The lamp is quite heavy and although the normal roof construction should be strong enough to carry it, care must be taken that it is fixed to the main timbers and not merely to the ceiling supports. Otherwise three fluorescent tube lights arranged in a triangle and suspended over the operating table give a surprisingly good and shadow free light.

Even if electricity is available, it may not be completely reliable and it is therefore unwise to design in such a way as to make it a necessity. Most surgical operations can be performed by daylight if the windows are well designed.

windows

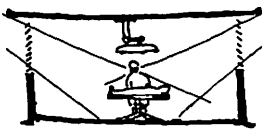

Windows should be at the head and foot ends of the theatre and be of the order of  $5 \text{ m}^2$  in area each. Most important the head of the windows should be high, at least 3.0 m above the floor to give a good angle and spread of light into the room. The cill can be about 1.6 m above the floor so that the wall below can be used for shelving and to ensure privacy from outside. The windows should of course face north and south and be shaded by a roof overhang of at least 800 mm. Roof lights are to be avoided in tropical countries due to the excessive heat gain caused by solar radiation. Reflective wall finishes such as high gloss paint or glazed tiles create glare which can cause eye strain and it is often suggested that pale colours are more restful to the eyes than white.

ventilation

Good and easily regulated ventilation is essential making adjustable glass louvre windows the best choice. Ideally the top and bottom areas of the window should be capable of being adjusted independently. In most places insect screening is a necessity but it should be borne in mind that this will cut down the flow of air through the window slightly.

## Sluice and Sterilizing Room

A room for the cleaning and preparation of instruments, utensils and linen is indispensable no matter what the surgical arrangement. The size and design will vary according to the function served within the hospital from a small intermittently used unit serving only the operating theatre (Figure 29) to a more comprehensive sterilizing facility serving other parts of the hospital with sterile packs of instruments and linen as well as the theatre (Figure 28). In either case the same design principles apply.

FIGURE 28  
sluice and central  
sterilizing

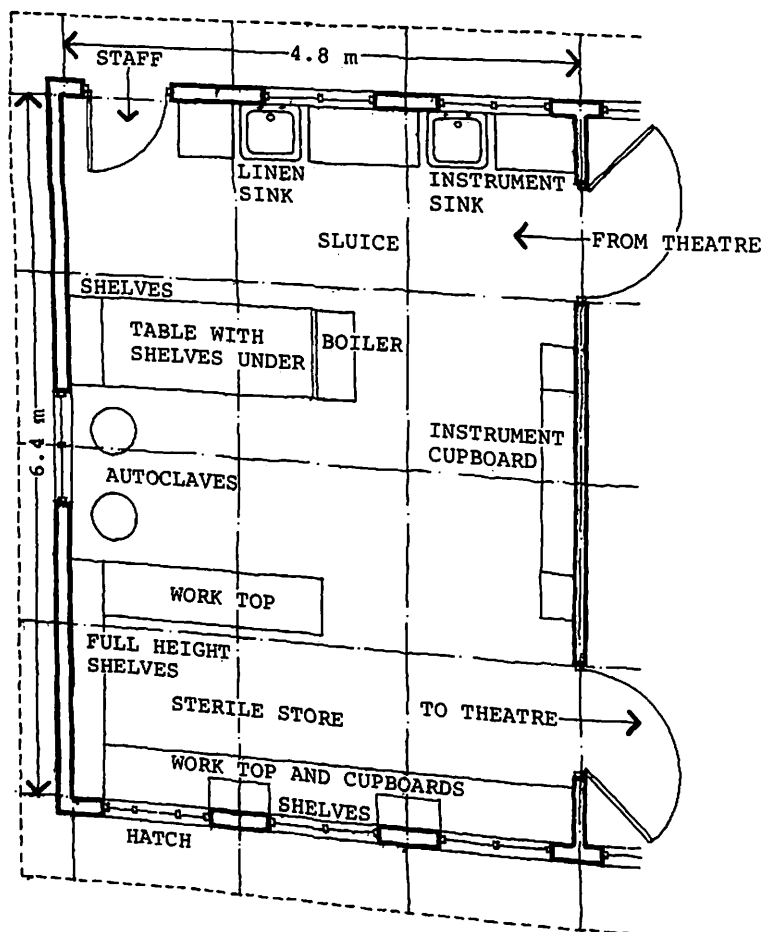

sterilizing process

The functional relationship of the sterilizing unit to the theatre involves the following processes. Used instruments and linen come from the theatre into the sluice area, the instruments are washed in a shallow sink and then loaded onto trays for sterilizing or put directly into a boiler. From there they are put back onto a trolley which returns to the theatre by way of the sterilizing area where further sterile items may be picked up. If the instruments are not required immediately they can be stored clean for future sterilizing or they can be packed, autoclaved and stored sterile. Linen is usually stored temporarily in the sluice area where a



deep sink is required for the immediate soaking of bloodstained or badly soiled items. From there it is taken to the laundry for washing after which it returns to be folded and packed into drums for autoclaving. A table at least 800 mm by 1.6 m is needed for this with shelf space for empty drums. After autoclaving it is stored in the sterile area. The separation of sterile and unsterile procedures and materials is vital and it is essential that the routes to and from the theatre are quite separate.

#### central sterilizing

If the sterilizing facility is to meet the needs of the entire hospital there arise conflicts of function between the intermittent specialized service required for the theatre and routine general sterilizing for the wards and outpatient department. There will also be a greater number of permanent staff who will need their own changing facilities. These factors require the sterilizing unit to be separated by doors from the theatre so that staff only enter the theatre when absolutely necessary. The larger number of staff and room area makes it possible and desirable that there be a clearer definition of the three zones of sluice, sterilizing and sterile store. There should only be outside access via the sluice area, possibly with a hatch in the wall of the sterile store area through which sterile packs for other departments can be collected (Figure 28).

#### fitted furniture

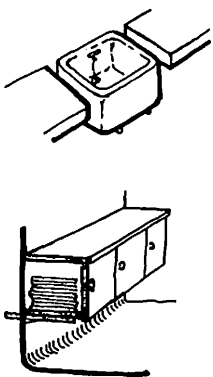

The observations in the previous section regarding cleanliness are equally applicable here. There will inevitably be a considerable amount of fitted furniture such as cupboards, work tops and shelves as well as sinks, boiler and autoclave. The best course of action is to separate, as far as possible, each item from the next and from adjacent wall and floor surfaces. It is virtually impossible, especially with a limited range of materials, to make a completely sealed joint between, for example, a sink and a work top or a cupboard and the floor, and it is these imperfect joints rather than the items themselves that harbour germs. In these cases a gap of 75 mm should be left between a ceramic sink and a concrete work top to allow cleaning in between and cupboards should, if possible, be raised above the floor. As in the theatre, shelves should be set away from the wall by 50 mm and be easily removed for cleaning.

#### choice of materials

The choice of materials, particularly for work surfaces is important. Terrazzo, which can be formed to make draining boards and sinks as well as ordinary work tops is ideal and has been used very successfully. If this is not available or is too costly, concrete slab surfaces are satisfactory although sinks should be of ceramic ware. Stainless steel sinks have a good surface but the way they are

formed creates crevices on the underside which will never be cleaned. Plastic laminate surfaces (formica, melamine etc), which are usually stuck on to plywood or blockboard, have a nasty tendency to delaminate in tropical climates and are best avoided. For shelving, marine plywood can be used but it is not often available in rural areas; alternatively planed timber or chipboard with a good paint finish (4 coats) can be used.

Ante Room

In this context the ante room is simply a lobby immediately adjacent to the theatre where the patient can be prepared and wait for admission to the theatre itself. The main advantage of such a provision is that it cuts down the time which elapses between the completion of one operation and the start of the next (Figure 30).

FIGURE 29  
minimal sluice and  
sterilizing

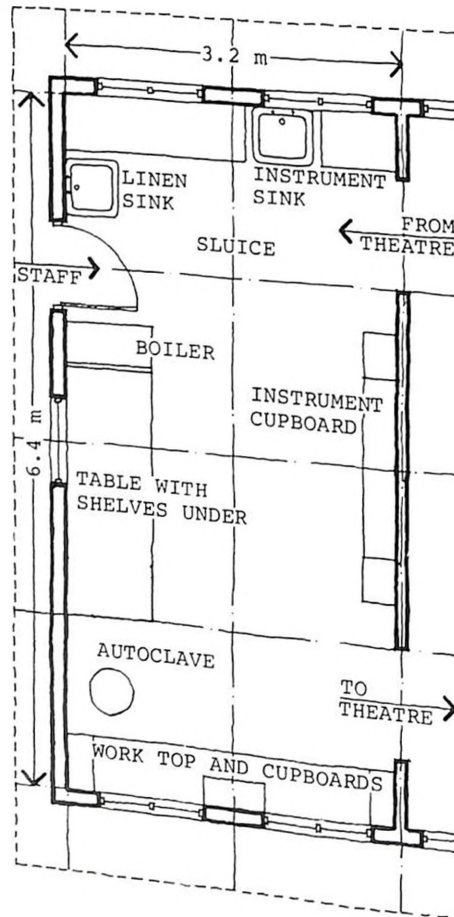
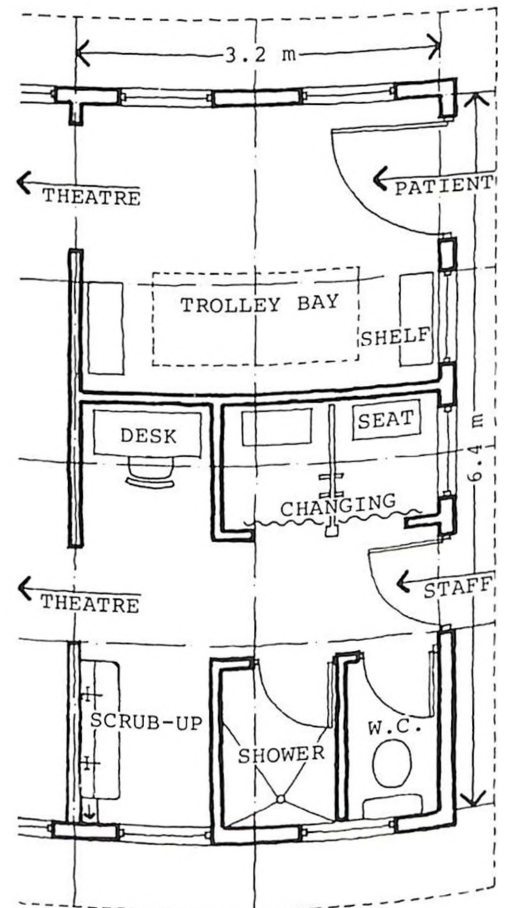

FIGURE 30 →  
ante room, changing and  
scrub-up



size

The ante room must provide a space large enough (say 3 m x 2.5 m) to park an incoming patient and remove his ward blankets and allow an outgoing patient to pass. Besides this there should be sufficient room around the waiting patient to allow for quick examination or minor preoperative procedures by the surgeon or

anaesthetist. It is sometimes proposed that X-rays, particularly of fractures, should be taken in the ante room, but if mobile equipment is available it can just as well be used in the theatre itself.

Once the operation is complete the patient should be taken straight from the theatre back to the ward. The usefulness of a separate recovery room in a rural hospital is debatable. It involves the duplication of equipment such as suction and oxygen apparatus and, more important, of staff, both of which are already available in the wards.

### Changing and Scrub-Up Room

To complete the series of functions which can be said to support the main activity of surgery, a room is needed in which the theatre staff can prepare themselves for their work. This facility can be dispensed with only if nearby changing rooms are available and scrubbing up is possible in the theatre. There is no fundamental objection to the latter and in cases where money and space are limited this is preferable to the alternative of scrubbing up in the sluice room.

facilities

The changing room should contain at least two changing cubicles (male and female) with coat hooks, a seat and a rack for outdoor shoes in each. It is highly desirable also to have a shower and w.c. unless these facilities exist very close by. A couple of chairs are welcome for resting between operations and a shelf placed at desk height (700 mm) can be useful for making notes or drinking coffee (Figure 30).

scrub-up

The scrub-up area must directly adjoin the theatre with, if possible, a low separating wall so that the surgeon can see the patient on the operating table while he is scrubbing up. The earlier comments regarding cleanliness, materials and fittings are equally relevant here. One important detail which is frequently overlooked is the necessity for mounting scrub-up basins sufficiently high (1.0 m from floor to rim) to avoid stooping, with the taps high enough above the basins (1.4 m above the floor) to ensure that both hands and elbows can be kept over the basin with the hands always higher than the elbows.



An alternative to scrub-up basins, which are expensive and sometimes unavailable, is to have an inclined panel, of galvanized steel or terrazzo, as a protection from splashing which is open at the bottom so that water can fall directly into an open

floor channel and from there straight out of the building. This also obviates the need for drainpipes which, besides being costly, can themselves be unsanitary.

#### Staff Changing Room

A small changing facility is needed for the staff who work in the sterilizing unit. Its size will depend upon the number of ancillary staff and whether the delivery room staff is also served. It is recommended that a small separate building is constructed so that future extension of the theatre block is not compromised. A changing room with about  $1.5 \text{ m}^2$  of floor area per person is needed. There should be a locker space for each person and at least one w.c., a shower and two hand basins. It may be convenient to locate a small cleaners' room with a sink and storage space for cleaning materials in the same building.

#### The Minor Theatre

The minor or 'septic' theatre can be located in the theatre block although, as mentioned earlier, its services are strongly related to the outpatient department. It will provide for minor surgical procedures such as the suturing of small wounds, opening of abscesses and the application of plasters.

size

The size of this theatre can conveniently be the same as the main theatre with much the same physical characteristics of good lighting, ventilation and cleanliness. The number of staff required for the surgical procedures is less, making the operating field smaller in area, but this is made up for by the fact that a number of supportive activities which, in the main theatre take place in ancillary rooms, are in this case accommodated in the theatre itself (Figure 31).

Thus, besides the space for an operating table there must be at least two sinks, one of which should have no waste trap so that it can be easily cleaned out if it becomes blocked by plaster of Paris. In addition a desk and chair are needed for making notes, a small bookcase for hand books, a lockable drug cupboard and a large amount of work top area and cupboard space. Immediately outside the door should be a covered area with a bench for a number of people to wait for their turn.

The relationship to the main theatre is mainly one of shared equipment and staff although it is possible that a patient could be transferred between one and the

other. There should, however, be no direct connection between the two in order to cut down the risk of cross-infection.

FIGURE 31  
minor theatre

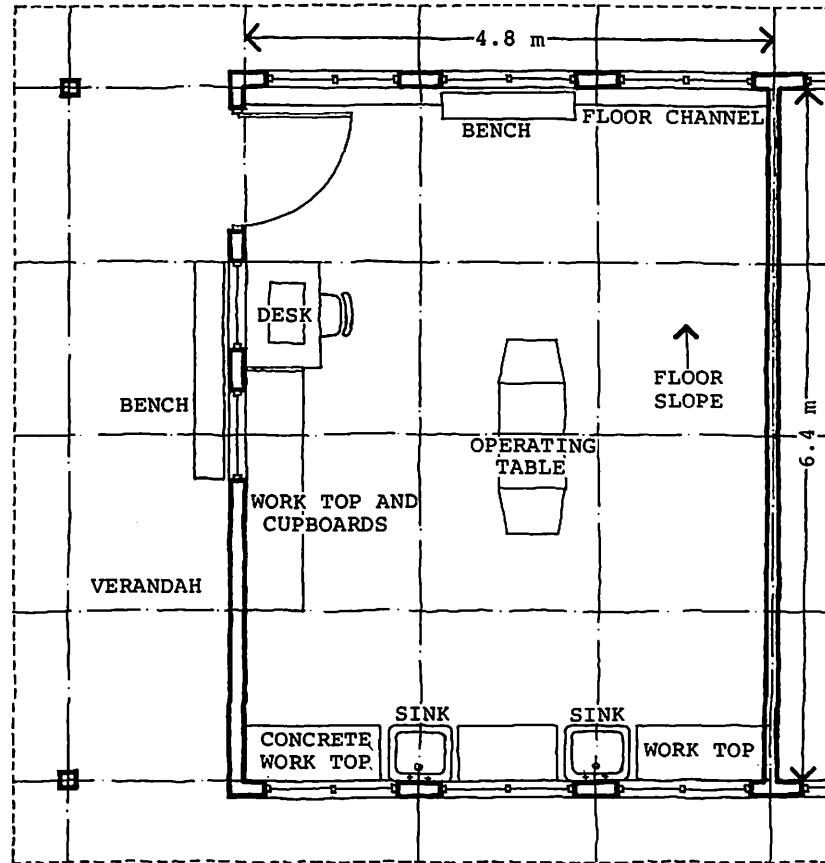

Handwritten notes: 4.8, 6.4, 1.2

delivery room

Although the delivery room has been taken into account in this section and may indeed form part of the surgical department (as in Figure 35), its detail design is dealt with however in relation to the maternity unit in the next section on the inpatient department.

page 73

Surgical Department Planning

The various elements described in the previous paragraphs can be combined together to form a surgical department to meet the needs of a particular situation.

the basic theatre

Figure 32 shows the minimum arrangement that is capable of coping with surgical work consisting of a theatre and small sluice and sterilizing room. This plan is not recommended for normal situations but in circumstances where funds are extremely short but nevertheless some surgery must be undertaken, it is an adequate and extremely economical solution. It could also be considered a stopgap measure



FIGURE 32  
the basic theatre

LEGEND

- Th - THEATRE
- Del - DELIVERY ROOM
- MTh - MINOR THEATRE
- Sl - SLUICE
- Ste - STERILIZING
- An - ANTE ROOM
- Ch - CHANGING
- D.R. - DUTY ROOM
- Sc - SCRUB UP
- Sh - SHOWER
- St - STORE

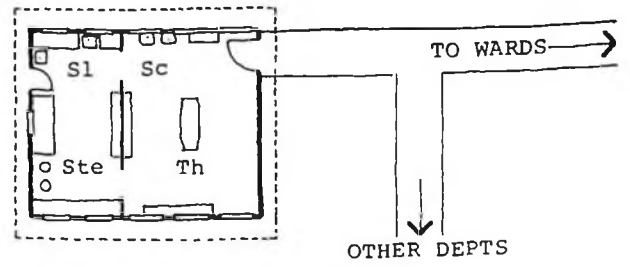

FIGURE 33  
intermediate theatre

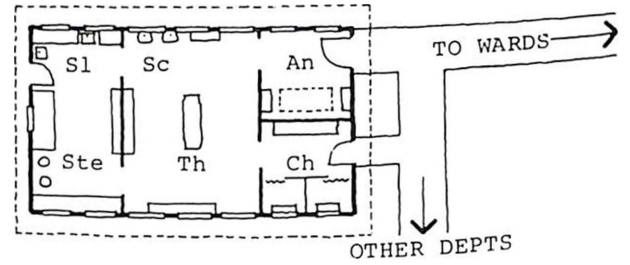

FIGURE 34  
recommended theatre

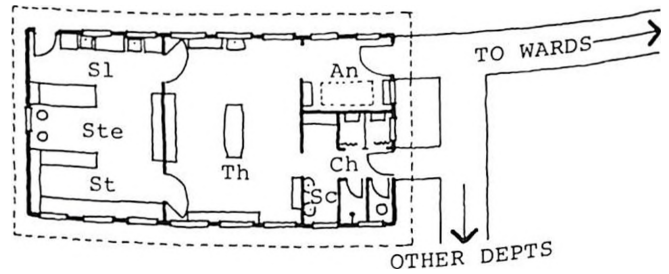
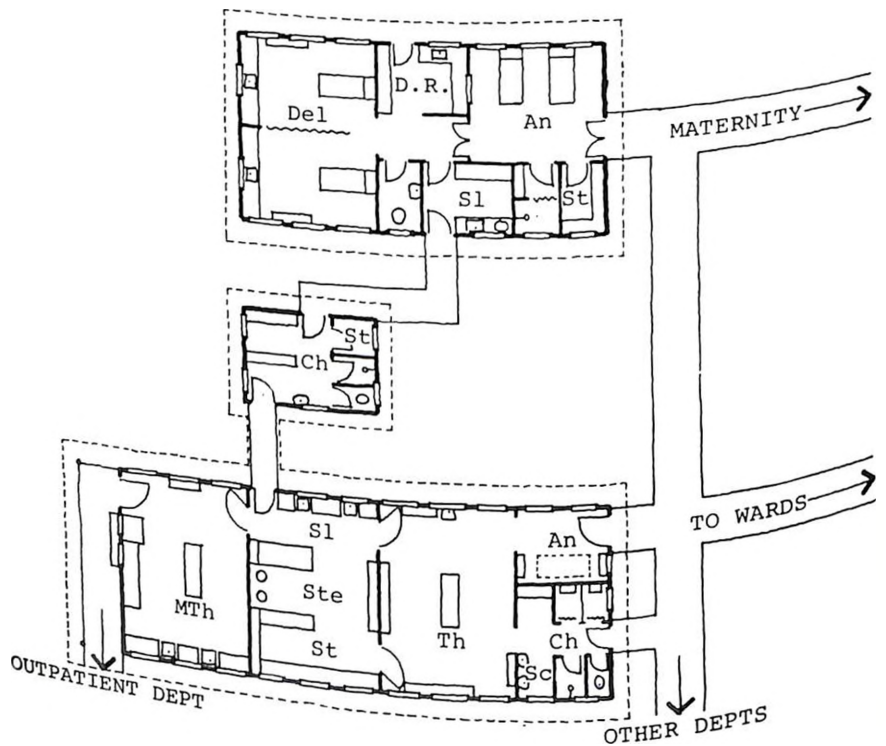

FIGURE 35  
full surgical department



capable of providing a service until it can itself be expanded or until a more comprehensive unit can be built from scratch.

intermediate theatre

The next step up is a similar arrangement but with an ante room and surgical staff changing room. This increases the efficiency of the unit by allowing for a quicker turnover of cases and, by providing amenities for the staff, enables them to be more productive. The small sterilizing unit is retained, making it unsuitable for situations where sterilizing for other departments is to be undertaken. For reasons of economy, scrubbing up takes place in the theatre and no shower or toilet is provided within the theatre block (Figure 33).

recommended theatre

The plan in Figure 34 with a larger sterilizing unit could be ideal for the average rural hospital where the theatre is in intermittent use but the sterilizing room is active daily, preparing sterile items for the wards and outpatient department. The changing room is provided with a shower and toilet and scrubbing up is separate from the theatre. Also a small changing room for sterilizing staff would be needed, probably in the position shown in Figure 35. While this is a great improvement over the minimum arrangement it should be borne in mind that its cost would be two to three times that of the basic theatre.

surgical department

Finally, a full surgical department composed of a main theatre, a minor theatre, a delivery room and all necessary ancillary rooms is shown (Figure 35). With this plan, should the load on the main theatre become too great, the minor theatre could be converted into a second main theatre with the surgical team alternating between the two. In this case an additional ante room could be added on at the further end of the building.

#### 4.5 THE INPATIENT DEPARTMENT

Essentially the inpatient department of a hospital provides care for those patients who need treatment at such frequent intervals that they must stay within the hospital. In the rural hospital it will consist of a number of general nursing units, a maternity unit and several self-care units.

##### The Nursing Unit

The general nursing units provide accommodation for patients who can only be nursed in beds, who require attention several times a day from the staff and who

are too ill to cook their own food and keep themselves clean. Whether they accommodate men, women or children or whether the patients suffer from surgical or medical diseases makes little difference from a design point of view.

childrens' wards

There is a tendency to regard the childrens' ward as a special unit requiring special facilities. In the rural hospital this is not necessarily the case. For many reasons it is desirable for a child, when admitted to hospital, to be accompanied by its mother. Firstly she will provide a homely environment; in many cases the child can be nursed in the mother's bed and in most cases the mother can provide basic nursing care for her child thus relieving the staff. Finally and perhaps most important, the mother will learn something about the care of sick children.

There are however some children who need to be nursed in their own beds, for example, those with burns or fractures. Even so an equal number of beds ought to be provided in the same ward for their mothers. This ward should be of the same design as the other nursing units in order to preserve the overall flexibility of the inpatient accommodation.

The nursing unit is made up of one or more bed wards and a number of supporting facilities such as the nurses' duty room, an examination room and sanitary accommodation. The optimum capacity of the unit is determined by several factors.

nursing unit size

The first is the availability and capacity of the staff. Observations have shown that although conditions vary from place to place, wards containing around 20 beds are optimal from a nursing point of view. The second consideration is that one w.c. will serve 8 to 10 patients satisfactorily and, although they are used less frequently, the same is true for showers because of their longer use time. Since no ward should have less than two w.c.s or showers it follows that a bed ward of less than 16 beds would be uneconomical. The third factor is the need to maintain maximum flexibility in the use of the total number of beds. The need for male, female and childrens' beds may vary considerably from time to time and, in a hospital with around 100 beds, the smaller the wards the more flexibility they will provide.

In this manual a nursing unit of about 20 beds is suggested although local experience may lead to a different conclusion. Nevertheless, the same design principles will apply.

intensive care

Besides the beds in the main ward, two single bed rooms, one of which can normally be used as an examination room, are needed for isolation cases or for patients needing special care. The question of whether to include an intensive care unit in a rural hospital is a controversial one. It should be borne in mind that only 1-2% of the patients will need intensive care, that is more or less constant supervision combined with clearing of airways, administration of intravenous drips, oxygen and drugs.

In a hospital with say 100 beds, an average of two patients will fall into this category. While the number can at times be higher, it is debatable whether these few patients should be nursed in a separate unit containing all the necessary facilities, and where at least one staff member is constantly on duty, or whether they should be treated in the corner of the general ward nearest the nurses' duty room. If the former solution is preferred then one or two of the single bedrooms in one of the nursing units can be set aside for this purpose without making any major design changes.

#### Bed Wards

Two basically different ways of arranging beds within a ward are possible, each with its own merits and shortcomings; both types are considered here. They require different overall building dimensions and consequently are not interchangeable once the building is completed.

'Nightingale' ward

The most commonly found ward in developing countries is the 'Nightingale' ward in which the beds are arranged in rows at right angles to the length of the room with a general circulation area down the centre (Figure 36). The chief advantage of this system is its economy in that a low floor area per bed ratio ( $5.1 \text{ m}^2$  per bed) is achieved and a relatively narrow building width (6.4 m) will suffice which allows for an inexpensive form of roof construction.

supervision

The 'Nightingale' ward is flexible in size so that any ward capacity can be achieved in increments of two beds whereas systems based on groups of beds limit the choices to say 8, 16, or 24 beds. From a nursing point of view opinions differ but it can be said that supervision of the whole ward is easily possible from one position and that the path from the nurses' station to any bed is direct.

patient environment

The chief disadvantage and the reason why this type of ward is being phased out in many countries is that its barrack room appearance provides a poor patient

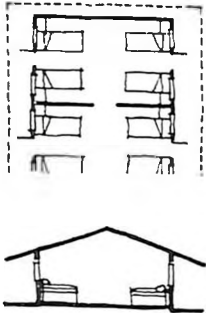
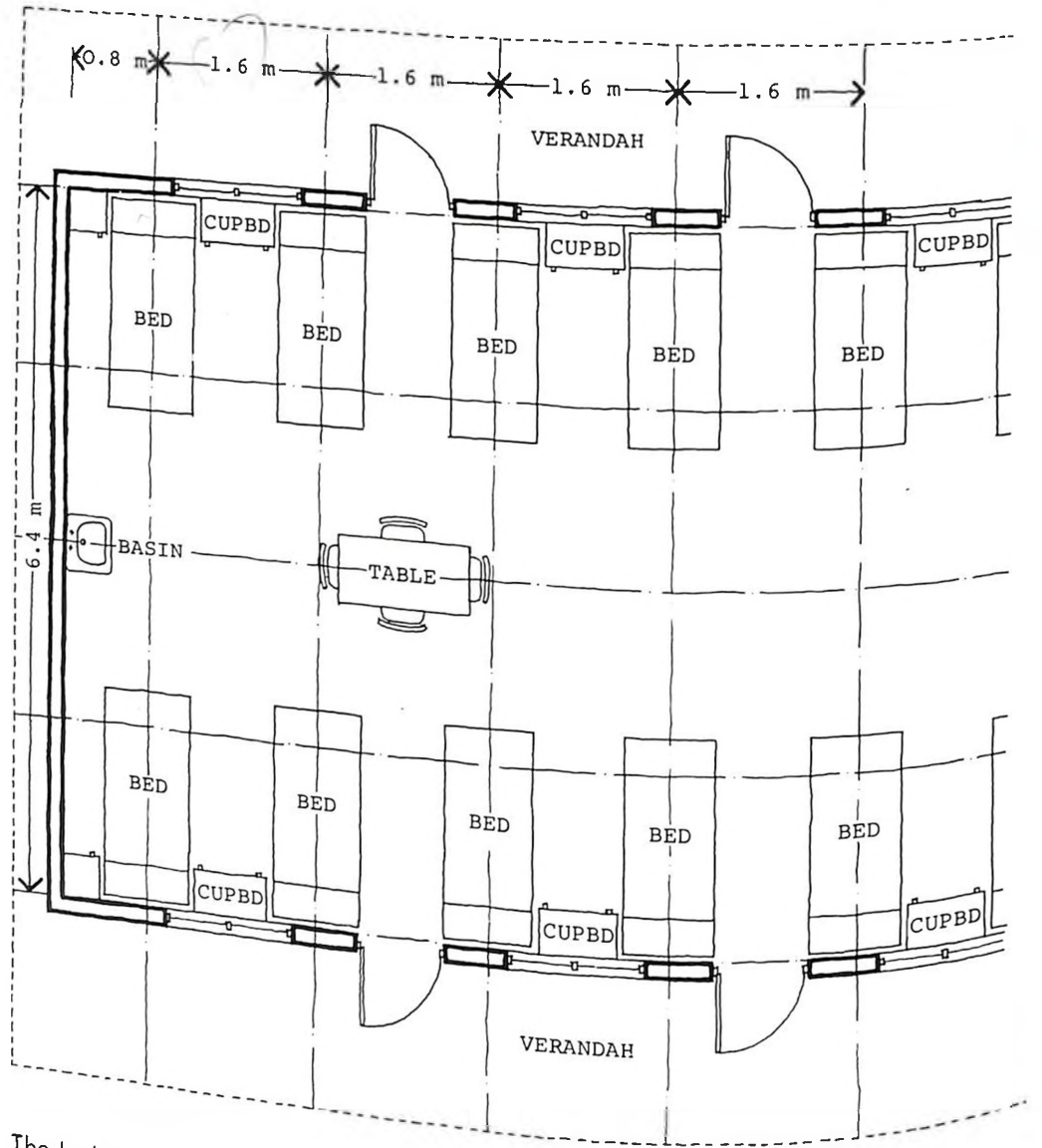

FIGURE 36  
the Nightingale ward



'Rigs' ward

The bed arrangement which is increasingly preferred is the so called 'Rigs' plan in which the beds are placed parallel to the axis of the building, usually in groups of four situated on either side of a central corridor (Figure 37). Alternatively, the beds can be in groups of six with a side corridor which is particularly effective where the corridor can be replaced by an external verandah (Figure 38).

supervision

The disadvantages are firstly that direct visual supervision of all the beds in the ward is impossible. In an adult ward this may simply mean placing those patients



likely to require most attention nearest to the nurses' duty room, but in a children's ward, it is usually desirable to have all the beds in view. Secondly, the arrangement of beds is such that if patients are moved in their beds, the manoeuvring is more difficult than in the 'Nightingale' ward requiring that the beds be more generously spaced. This leads to the third disadvantage of the 'Rigs' plan, namely that the floor area per bed ( $5.6 \text{ m}^2$ ) is higher and the necessary span of the building greater (8.0 m) both of which tend to make it more expensive than a Nightingale ward. A comparison of overall ward sizes and area per bed is made in Figure 38.

FIGURE 37  
the Rigs ward

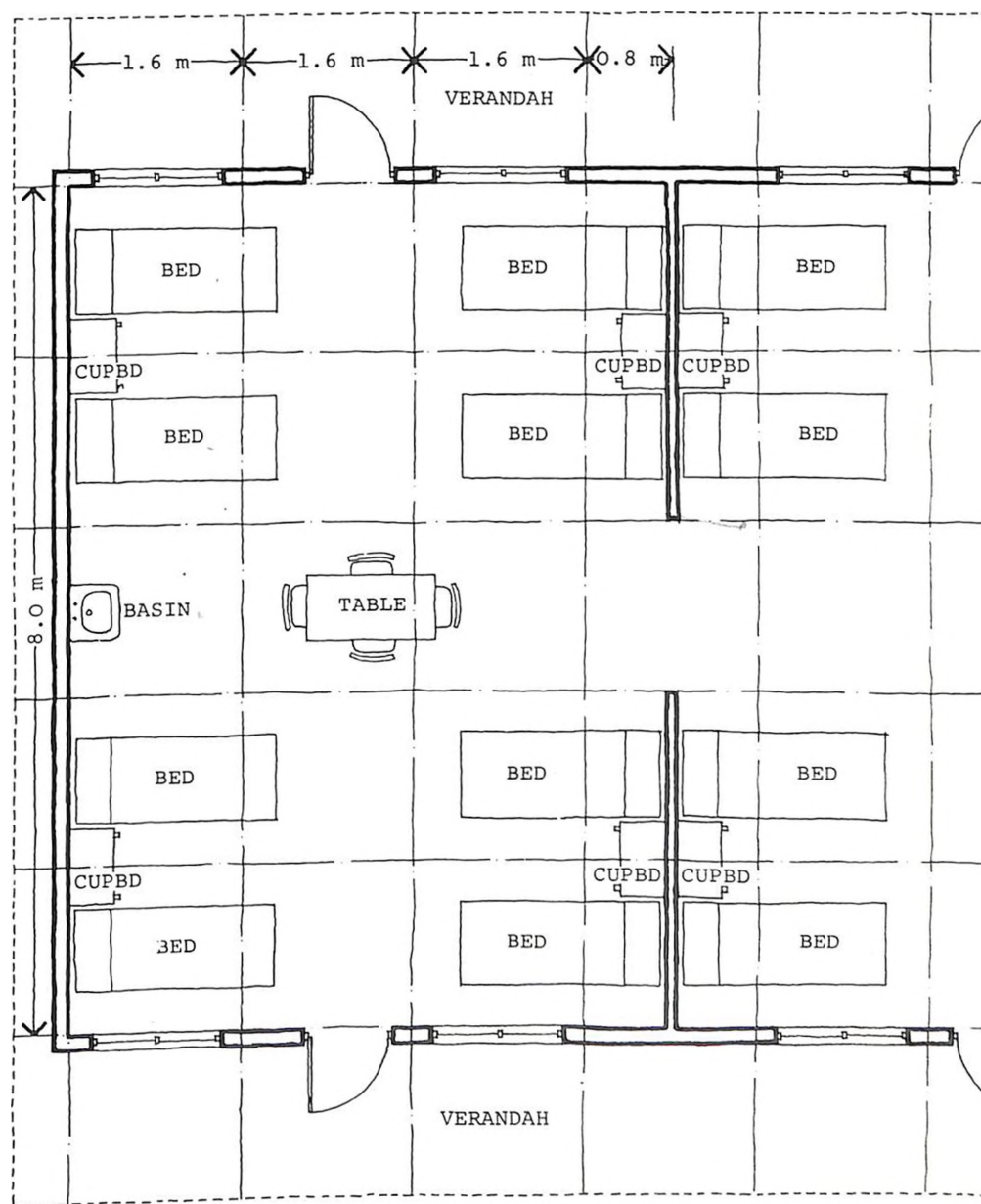
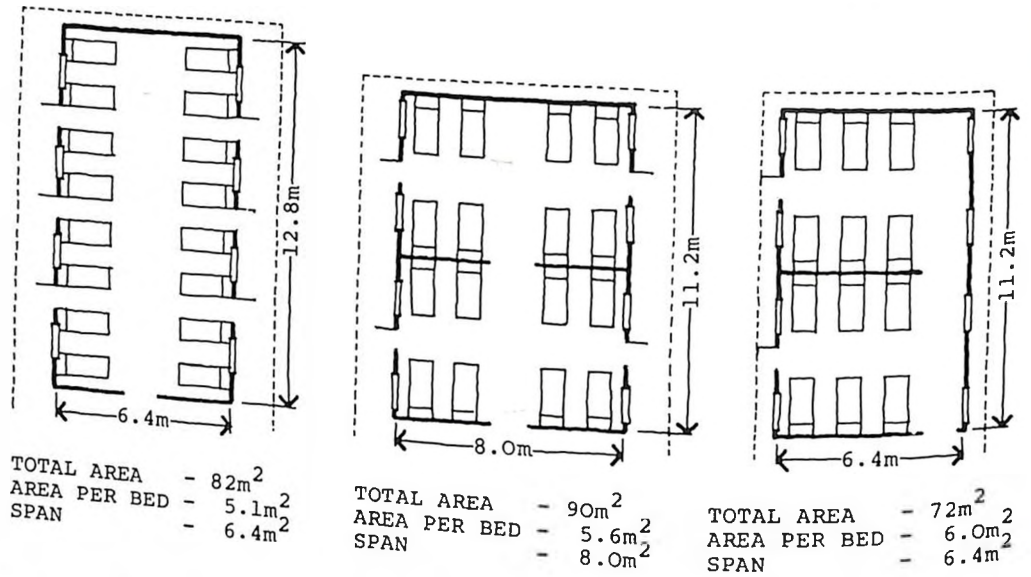

FIGURE 38  
area per bed comparison



patient environment

The chief advantage of the 'Rigs' plan is the improved quality of patient environment it produces due to the smaller groupings of beds and the fact that natural light falls from the side rather than from the front and back of the patient.

The general use of two or four-bedded rooms is not considered here, firstly because of their higher cost and secondly because without electronic calling systems it is virtually impossible to supervise such arrangements.

bed spacing

page 34

As mentioned earlier in this chapter, a bed spacing of 1.6 m is suggested based on an 800 mm wide bed with an 800 mm space in between. This gives a fairly compact arrangement reflecting the commonly felt need to accommodate as many beds per ward as is reasonable. On the other hand, the beds should not be squeezed any closer together. This can be discouraged by fixing bedside cupboards to the wall at the proper intervals and further by placing doors in alternate spaces between the beds. Also the unsatisfactory practice of placing beds in corners can be prevented by the same means (Figure 39).

FIGURE 39  
the Nightingale ward  
(section)

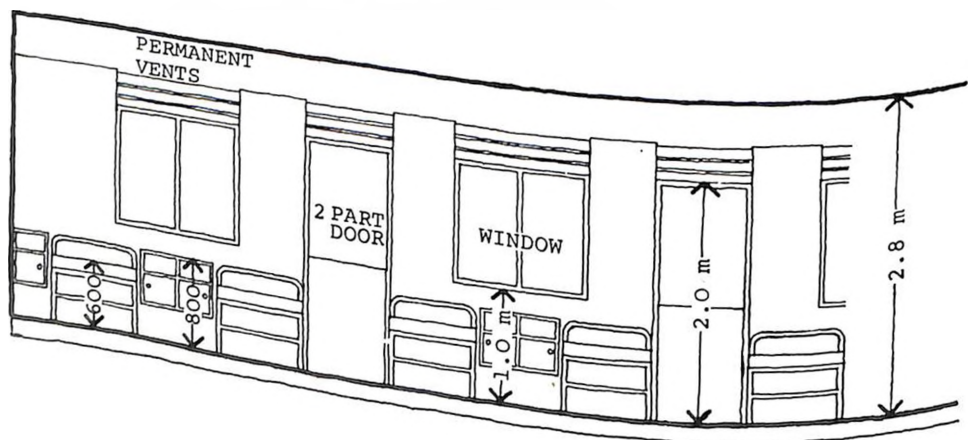

#### ward design

Besides room for the beds, each ward needs additional space for general circulation and one or two tables for ambulant patients to sit at and take their meals. A wash basin should also be provided in each ward. Ideally, verandahs, where patients can relax during the day, should run along each side of the ward. These can be connected to the ward by several doors so that patients and visiting relatives do not cause congestion around the main entrance. As the wards are quite large rooms, the ceiling should be fairly high (say 2.8 m) and the space well lit and ventilated.



Wherever possible bed tables and cupboards should be fixed directly to the wall clear of the floor and the floor itself should slope towards the outside doors to facilitate washing down. Another useful detail is to incorporate a step skirting of 50 x 100 mm to prevent beds being pushed against the walls and damaging them.

#### ward construction

The wards can be constructed very simply, for example the floor can be of plain concrete with a roof supported on brick or concrete piers and the walls filled in with local materials such as mud and wattle. In many climates there is no need for a ceiling and the window openings can be unglazed with only a simple timber shutter. This type of construction will result in a considerable saving of money which, bearing in mind that the wards account for a large portion of the total floor area of the hospital, will cut the overall cost substantially.

#### duty room

The nurses' station or duty room ought to be immediately adjacent to the bed ward. It should contain a work area with standing height work tops and cupboards, at least one of which should be lockable for drugs, also a sink and space for a boiler. Some of the work top area should be clear underneath to allow trolleys to be parked. At the other end of the room a work top at desk height will be needed for writing as well as two or three chairs. The detail design of the duty room should be made in full consultation with the matron and nursing staff.

#### examination room

A small room is needed in each nursing unit for private examination and consultation with patients, usually by the doctor. This room can also be used for minor treatments such as the changing of dressings. It should contain an examination couch, a wash basin and a small desk. As mentioned previously, this room can serve alternatively as a second single bedroom.

#### sluice and storage

A sluice room for washing utensils, emptying bed pans and the temporary storage of soiled linen is needed. It should contain a concrete work top with a ceramic

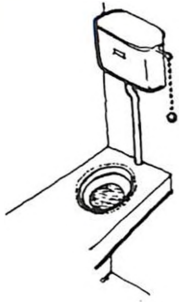
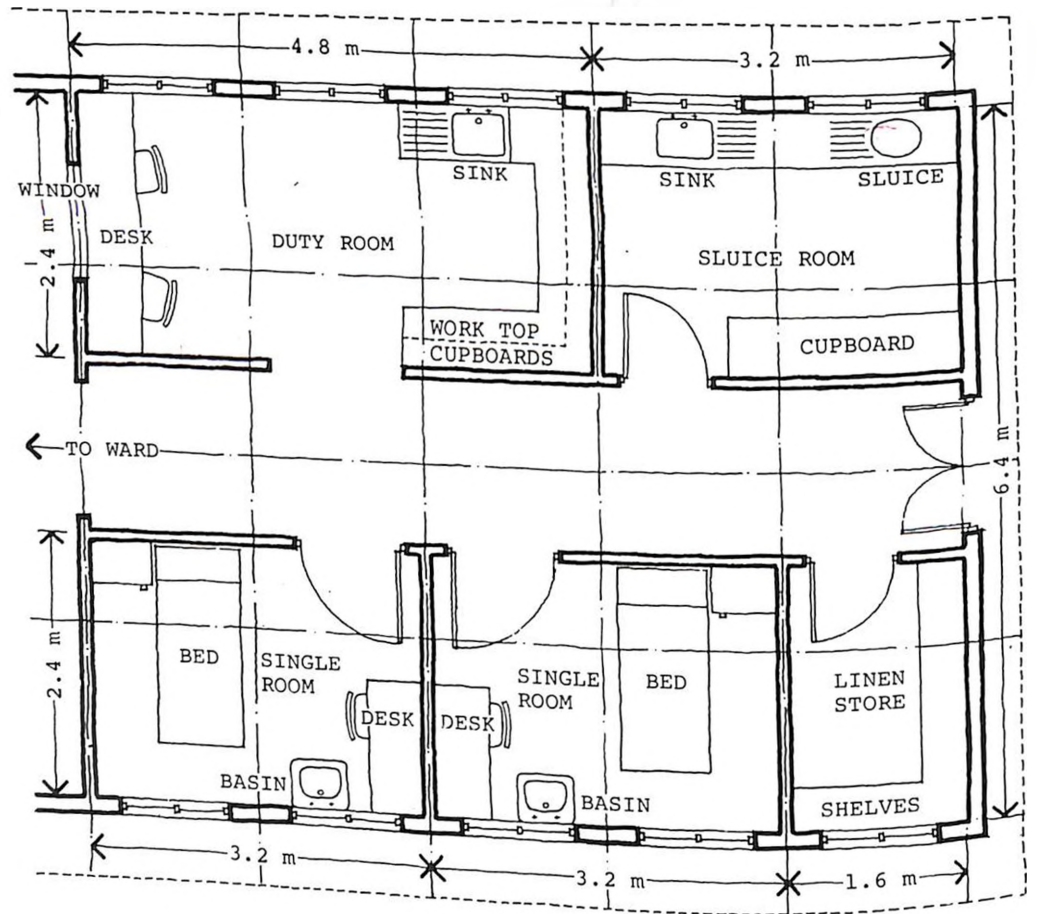

FIGURE 40  
nursing unit ancillary rooms



sanitary facilities

A sanitary block containing a w.c., shower and wash basin for each 8 to 10 patients should serve each nursing unit. The building should be well ventilated and blocks serving adjacent units can be placed next to one another to obtain economies in the installation cost. An important design factor is the location of the sanitary facilities. Most people will not use a toilet which opens directly off a habitable space, including a ward. This fact coupled with the nuisance that can arise from the spread of odours from the toilets into the rest of the building make it desirable that the sanitary block is situated outside the main building. The separation need not be great and the route between can be covered against the weather (Figure 41).



FIGURE 41  
nursing unit sanitary block

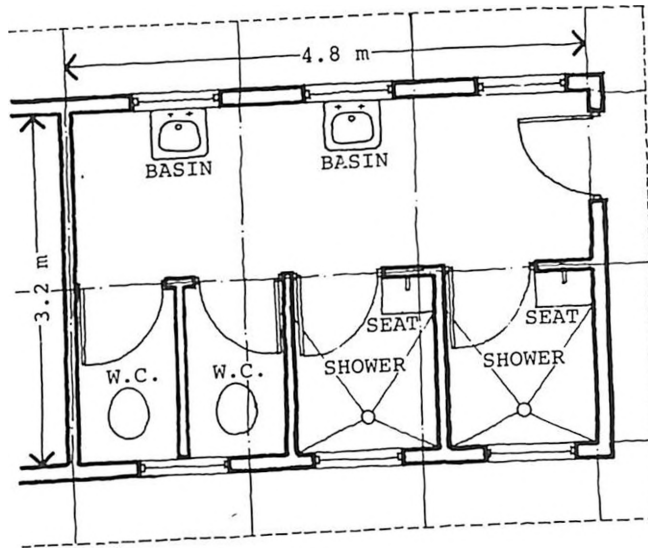

1.6  
4.8  
8.0  
1.6  
-----  
6.4 3.2

Planning of Nursing Units

Figure 42 shows how the various elements of the nursing unit can be combined together. A 'Nightingale' ward is shown but the same arrangement could be made for a 'Rigs' ward. The building would simply become wider and the supporting facilities re-apportioned accordingly. There are two alternative positions for the sanitary block, at the side or the end of the ward. The choice depends upon the relationship to other nursing units and the overall planning of the inpatient department.

FIGURE 42  
nursing unit

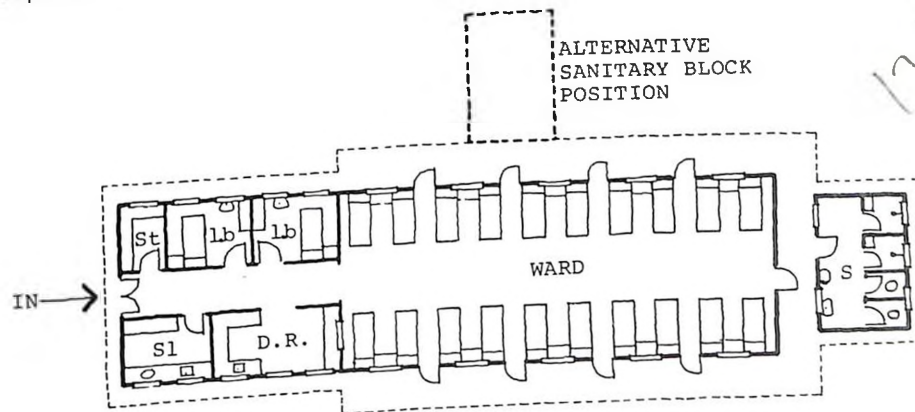

LEGEND

- D.R. - DUTY ROOM
- Sl - SLUCE ROOM
- lb - ONE BED ROOM
- St - STORE
- S - SANITARY BLOCK

12.8  
4.8  
-----  
17.6  
6.4  
-----  
11.2

inpatient department layouts In Figure 43 two different layouts of nursing units are shown, one with the buildings at right angles to the circulation route and the other with them parallel to it. In the latter case, the supporting rooms of two wards are joined together with a



common entrance which means that some of the rooms such as the sluice, examination room and linen store can be shared. In each layout four nursing units each with a 20-bed ward and two one-bed rooms are shown giving a total of 88 beds. The same arrangement could, however, be used with smaller or larger capacity wards to meet specific requirements. Although general nursing units are indicated, a maternity unit could easily be added or substituted.

FIGURE 43  
inpatient department

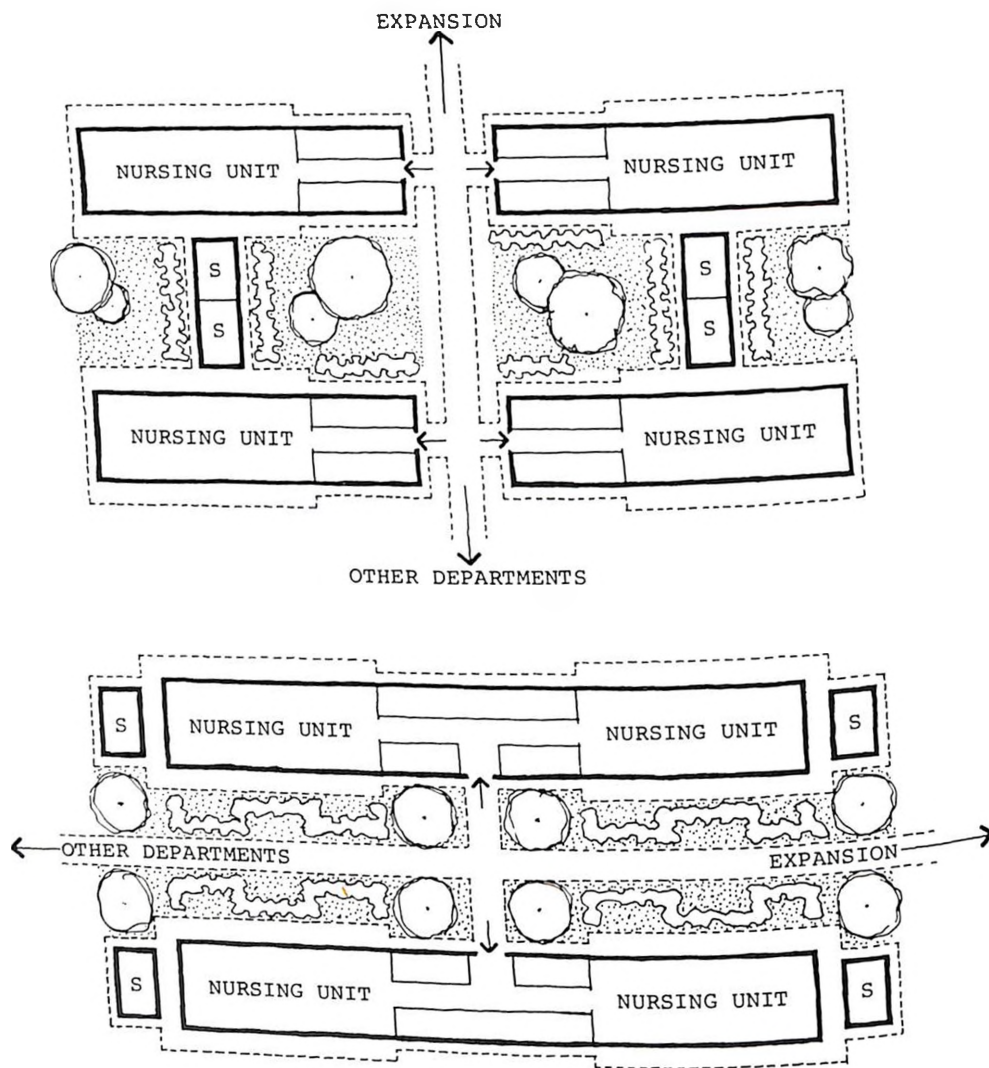

### The Maternity Unit

The maternity unit consists of a nursing unit which, with minor modifications, can be of the same basic design as the general nursing units, and a delivery unit.

capacity

The capacity needed in the two units differ from place to place depending on the attitude of the local population, the availability of maternity beds in health centres in the surrounding area, the size of the catchment area and the transport

situation. In most hospitals it would be reasonable to set aside 20% of the total number of beds for maternity use, provided these are used for postnatal patients and their newborn babies only. Antenatal patients should be catered for in a hostel or self-care unit unless special conditions warrant their admission for treatment. In this case they can be looked after in the female ward or in the separate bed rooms in the maternity unit itself.

### Maternity Nursing Unit

In most places it is an accepted, and perfectly acceptable, practice to leave newborn babies with their mothers so that cots for babies are not needed in the wards. Where there is strong feeling that cots are needed, these should be in the form of cradles attached to the foot ends of the mothers' beds where they will take up no extra space.



maternity ward

There should be room in the maternity bed ward for a free-standing table where the staff can demonstrate simple practical baby care to the mothers. Free wall space should be fitted with blackboards, pin boards, and any other teaching aids so that maximum use can be made of the patient's stay in the hospital for health education.

'premature' room

All maternity units should have at least two single bedrooms where special cases such as eclampsia patients can be adequately nursed. A special room for premature babies is a necessity. It should be close to, and have large glass windows facing, the nurses' duty room for easy supervision and so that parents can see their babies without having to enter the room. The room should contain enough space for four cots, a table for changing the babies, a wash basin and resuscitation equipment.

Finally the linen room and sluice room should be of generous size because of the special demand for frequent changing of soiled linen.

### The Delivery Unit

Whether the delivery unit is built in direct continuity with the maternity ward or as a separate block is of minor importance, especially if it contains a waiting bay for patients in the first stages of labour. It should if possible, however, be placed near the operating theatre so that a patient can be easily transferred should the need for surgical intervention arise (Figure 35).

waiting area

The delivery unit should contain a waiting bay for patients in beginning labour which can also be used for the examination of the patient when she arrives. Close to it a shower room is needed which is large enough for the nurse or midwife to assist the patient in bathing; hand rails should be provided for the patient to hold onto. A small lobby for undressing is also useful (Figure 44).

FIGURE 44  
delivery unit ancillary  
rooms

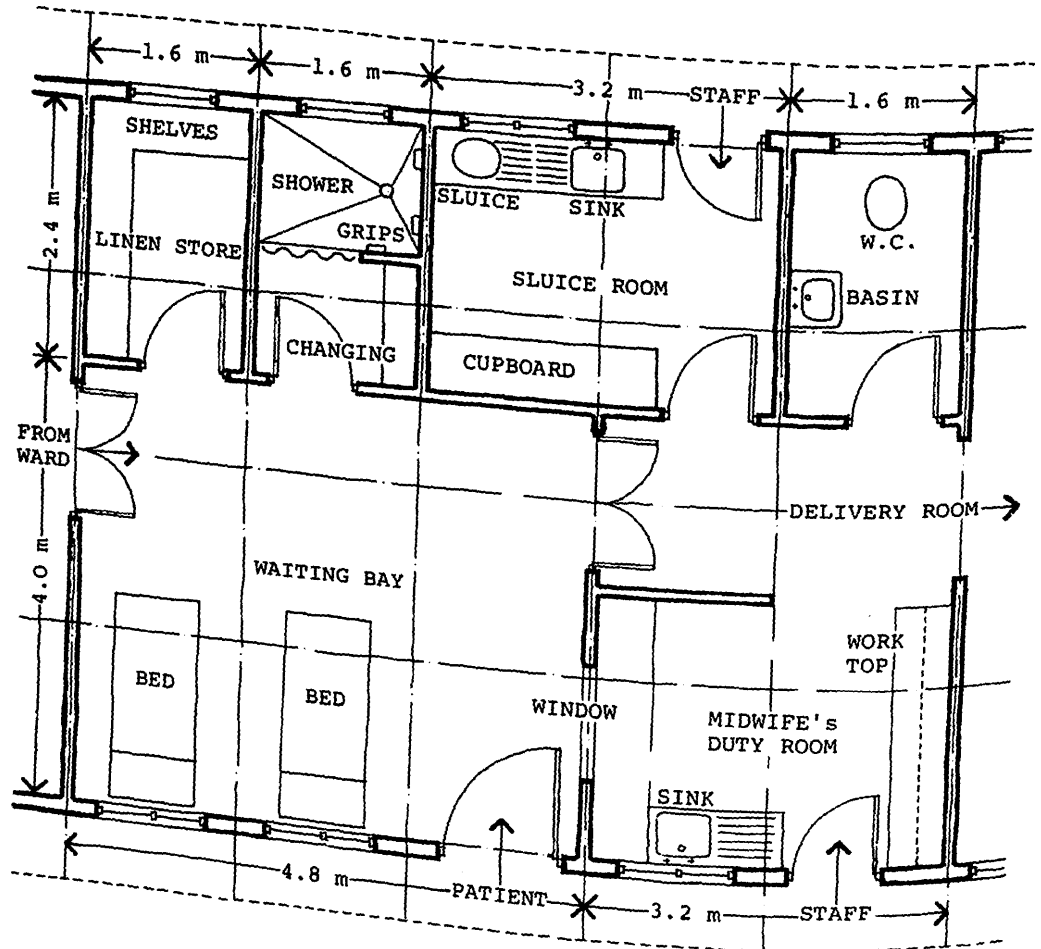

duty room

The midwives' duty room should be placed so that easy supervision of both waiting area and delivery room is possible. Apart from desk space, it should contain a drug cupboard, stores for instruments and suture material, a boiler, spacious work tops and a wash basin. A separate exit from this room is useful for the staff.

w.c. and sluice

Also next to the delivery room a w.c. is needed. Enemas are often given during labour and it is impractical for the patient to have to move to the other end of the building to reach the toilet. The sluice room can be next to the w.c. and should have a sink and sluice set into a concrete work top. It too should have its own outside door so that soiled linen can be taken directly out to the laundry. A further small room is required for the storage of clean linen.

At the appropriate stage in labour the patient is taken into the delivery room (Figure 45). The design criteria for this room are not dissimilar to those for the operating theatre and the observations in Section Four of this chapter about lighting, ventilation and floor and wall surfaces apply equally here.

FIGURE 45  
delivery room

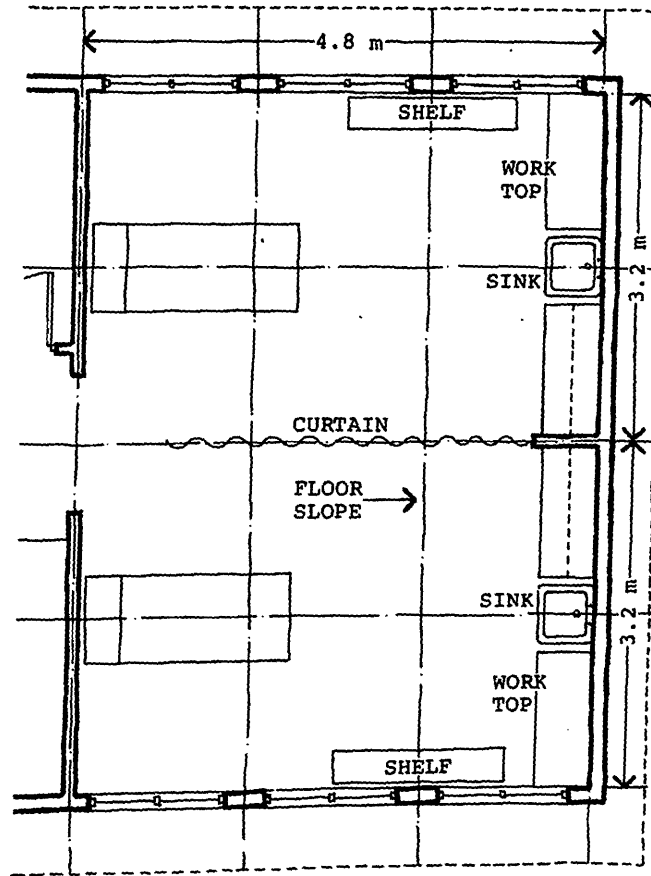

There should be space for two delivery beds with ample room on both sides as well as at the foot. Two ceramic sinks with adjacent work tops are essential, the latter placed high enough for trolleys to be pushed under them. Shelves for sterile drums and a 'high' shelf for gloves and gowns are useful. Both work top and shelf design can be as proposed for the operating theatre.

Finally a changing room and w.c. for the delivery unit staff is no luxury where the midwife and her assistants are working often long hours. If the unit is near the theatre block, this facility can be shared with the theatre staff (Figure 35).

#### Planning a Maternity Unit

Figure 46 shows a plan for a complete maternity unit. The arrangement of the four main elements, the ward, its supporting facilities, the delivery unit and the



FIGURE 46  
maternity unit

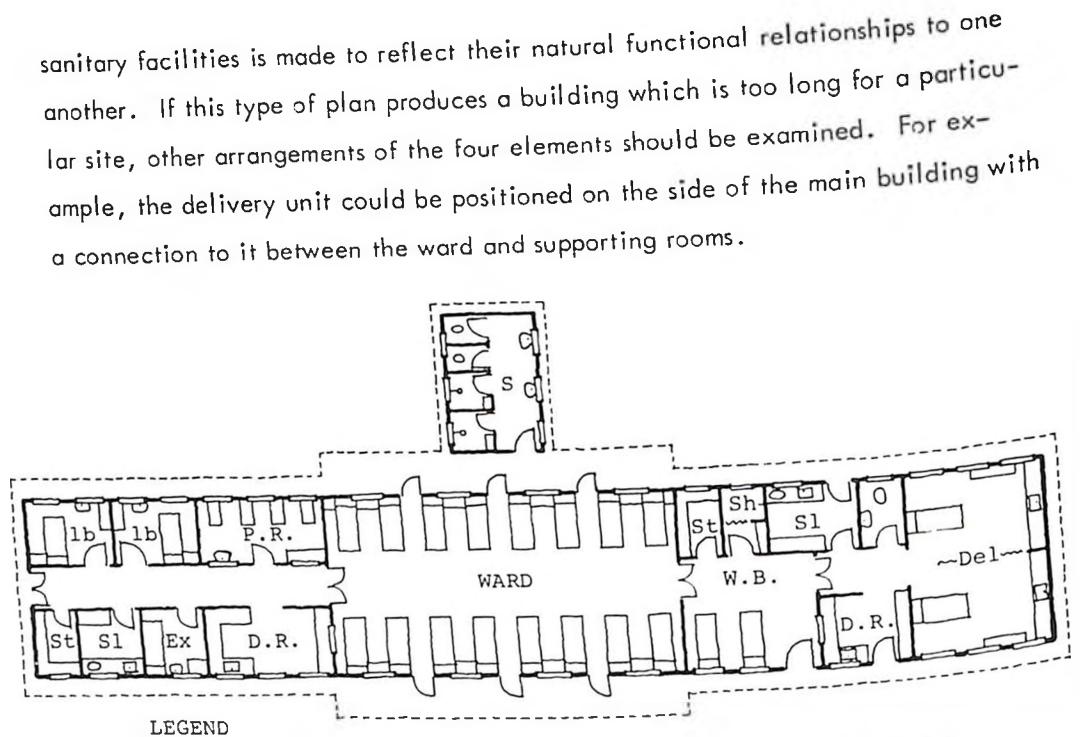

**LEGEND**

D.R. - DUTY ROOM  
 Sl - SLUICE ROOM  
 1b - ONE-BED ROOM  
 Ex - EXAMINATION  
 P.R. - 'PREM' ROOM

Del - DELIVERY ROOM  
 S.B. - SANITARY BLOCK  
 Sh - SHOWER  
 W.B. - WAITING BAY  
 St - STORE

Self-Care Units

There is one more group of patients who at present take up nearly half the beds in most rural hospitals and who could and should be accommodated in wards different from, and cheaper than, the standard nursing unit. These are the patients who are able to look after themselves, who can cook their own food but who cannot be adequately treated as outpatients. This group includes patients who need dressings or injections several times a day, and pregnant women who are booked for delivery in hospital, but who live so far away that they would be unable to reach the hospital in time if they were to wait for the delivery to start at home.

composition

The rational answer to the needs of these patients is a number of hostel-like self-care units near the hospital nucleus. Each unit can be composed of several four-bed rooms each with lockers for the patients' clothes. A communal kitchen for each 4 to 6 rooms should be provided, with a sink and a raised cooking slab, the latter to discourage the dangerous practice of cooking on the floor (Figure 47).

sanitary facilities

In many places where water is in short supply the sanitary facilities need consist only of well made and maintained pit latrines as long as decent washing facilities are available. The ideal solution, of course, is to provide a sanitary block



similar to that for the nursing units though in this case a ratio of one w.c. for 12 to 15 patients would be satisfactory. The sanitary facilities should be a little way away and could be shared between two or more units.

FIGURE 47  
self-care unit

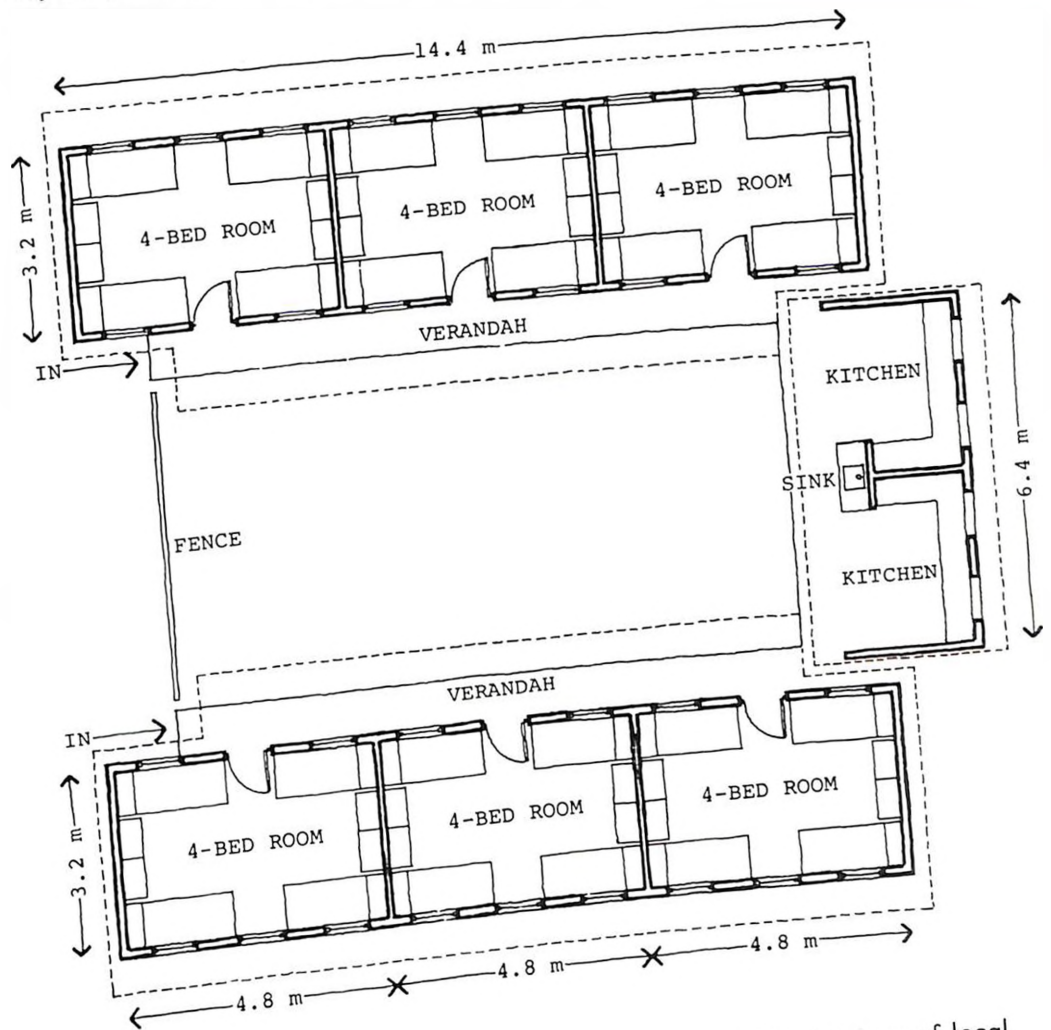

construction

Self-care units can be constructed very cheaply taking full advantage of local materials and methods of building. There is actually no reason why they should differ in any great way from the patients own homes except perhaps in terms of spaciousness and light and ventilation standards. Ideally the self-care wards should be a model of high quality traditional construction.

#### 4.6 MORTUARY

In most rural hospitals post mortem examinations are only performed infrequently, nevertheless a small mortuary will be needed. It should be sited on the leeward side of the hospital with separate vehicular access.

design

A single room of similar size to the examination room in the outpatient department ( $15 \text{ m}^2$ ), with a wide door for stretcher trolleys is needed. In the middle of the room should be an autopsy table 2 m long by 750 mm wide with the head end towards the door. The table can be made of concrete with slightly raised sides and a central gully sloping towards a ceramic sink at the foot of the table. The sink should have a laboratory type tap to which a hose can be attached for sluicing down the corpse and slab.

Along the wall at the opposite end of the room to the entrance should be a concrete work top and sink for the examination of organs removed from the body. This work top should also have a raised edge and slope towards the sink, also fitted with a hose. On the side walls there should be ample shelving for instrument containers and chemicals with some of the shelving set at work top height (900 mm) so that it can be used as a desk for making notes.

construction

The type of construction and detail design can be similar to that proposed for the operating theatre. A high standard of natural lighting and ventilation is required and the surfaces must be easily washed down. In this respect a sloping floor with an open channel leading directly outside is most useful.

Provision for storing bodies is not usual in a rural hospital because when patients die they are normally taken straightaway by their relatives. If however it is necessary, due perhaps to the proximity of a main road where traffic deaths may occur, then one or two separate, well ventilated small rooms of approximately  $6 \text{ m}^2$  each can be provided opening directly off the autopsy room itself.

#### 4.7 ANCILLARY SERVICES

Besides the strictly medical functions of the hospital, there are a number of essential supporting functions to be housed. The most important of these are the laundry, kitchen, workshop and garage. These elements, besides sharing a common service function, require a similar standard of construction so that in a new hospital they could be placed together in a single block somewhere on the edge of the nucleus. Certainly there are good reasons for placing the laundry and kitchen together; they both serve generally the same parts of the hospital and both consume large amounts of hot water. The garage and workshop on the other hand serve the hospital in a less direct way and it is probably more important to consider vehicular access and the noise nuisance they may generate than solely proximity to the other hospital buildings.

## Laundry

Dirty linen from all parts of the hospital is usually collected daily into a central location for laundering. The process involved is fairly straight forward. An area is needed for receiving and sorting the dirty linen and a sink should be provided for soaking badly soiled items. For washing at least two sinks are required, one for soaping and one for rinsing but four would be preferable for a small hospital. Each sink should be a minimum of 600 x 500 x 400 mm deep with a sloping front to facilitate scrubbing. An alternative arrangement is to have, instead of a sink for soaping, a sloping slab with a channel drain along the back and two or three taps above. In any case, draining boards at least as wide as the sink should be provided at each side. Both sinks and draining boards can be made of concrete or of galvanized metal if that can be fabricated locally. Stainless steel sink units are totally inadequate for laundry purposes and ceramic sinks are too vulnerable to chipping (Figure 48).

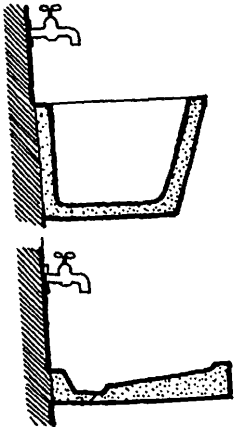
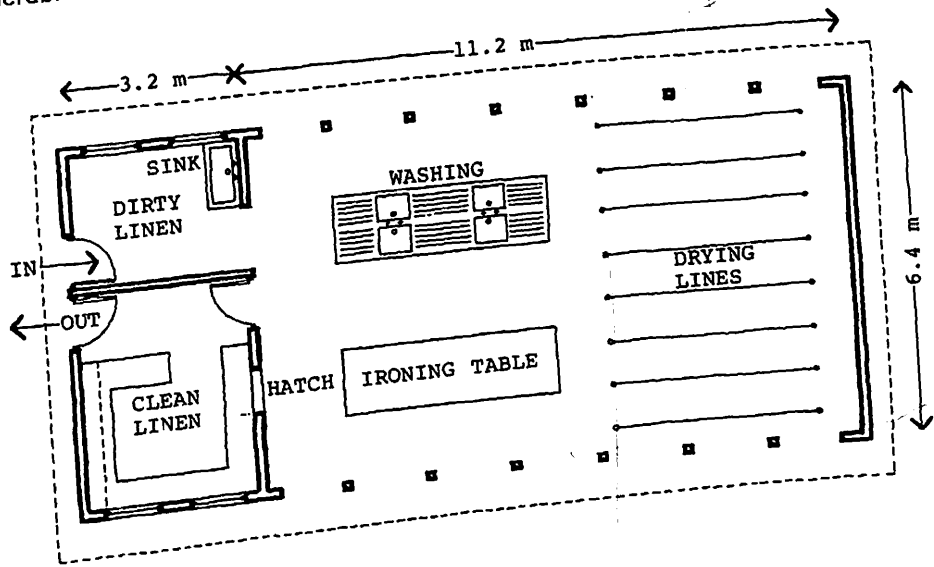

FIGURE 48  
laundry



use of water

Laundries can use a vast amount of often precious water. Even if generally rainwater is not conserved, it is sensible to design the laundry roof so that water can be collected, rainwater being soft and therefore ideal for washing purposes. It is also possible to re-use rinse water for soaping the next batch.

drying and ironing

After washing a large area is needed for drying lines; (0.8 m<sup>2</sup> of drying area is required per bed sheet) this is generally outside except of course during rainy periods when there must be adequate indoor drying. Even this can be unsatisfactory due to the higher humidity levels in the rainy season and therefore the drying area should be well ventilated and preferably provided with some source

of heat. Sometimes the hot water boiler is situated in the centre of the drying area. Nearby there should be a large ironing table, preferably free-standing to allow people to work all around it. If electricity is not available hot-plates will be needed for heating up flat irons.

linen room

Finally a clean linen room is needed with ample slatted shelving for airing and from where linen is dispatched back to the different parts of the hospital. A small lock-up store is also useful for keeping laundry materials in. The construction of the laundry can be a very simple 'open' type, but the floor should be made of concrete laid to a slope so that it will drain itself.

### Kitchen

The internal arrangement of the kitchen depends upon the catering system of the hospital. In many places, for example, most of the patients' food is prepared by relatives, leaving only those on special diets to be catered for by the kitchen. If however all the patients are served from the kitchen, the system is usually that the food is sent out in large containers, say one for each ward, with an equivalent stack of clean plates. The food is then served from a trolley in the ward itself and then the dirty containers and dishes are collected up and returned to the kitchen for washing.

FIGURE 49  
kitchen

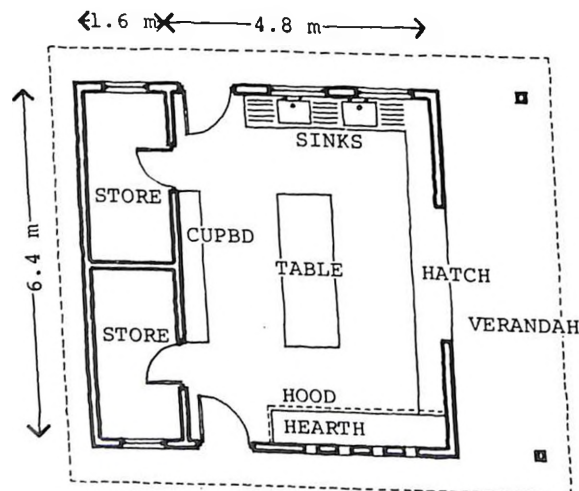

kitchen design

Figure 49 shows a kitchen arrangement suitable for this kind of system based upon the needs of a hospital of around 100 beds. Unless a great deal of money is available for sophisticated equipment, the kitchen design should not be too specialized.

In cooking, for example, any number of fuels may be used in all manner of cooking devices. A raised concrete plinth with a large galvanized metal hood above connected to a flue to collect the smoke, can serve as a hearth upon which cooking can take place.

sinks

For food preparation and the later washing of dishes, two large sinks are needed with ample draining boards on each side. Again the sinks can be of concrete but here they should not be so deep as in the laundry. A shallow sink of 250 mm will cause less fatigue through bending. The taps should, however, be placed high enough above the rim of the sink to allow large cooking pots to be washed.

Work top areas are useful but there is no substitute for a large wooden table (say 1.2 x 2.4 m) around which a number of people can sit preparing food. Drawers and cupboards are needed in the kitchen for utensils in regular use and a large well ventilated and secure store room is needed which can be compartmented for dry goods and fruit and vegetables.

Construction of the kitchen can be the same as the laundry and a similarly high standard of ventilation is needed. In fine weather much of the work of cooking and preparation will go on outside and allowance should be made for this.

kitchen teaching

Kitchens sometimes fulfil a very valuable secondary function of nutritional education where mothers in particular can be instructed on the nutritional value and best methods of cooking different foods. In this respect the kitchen should represent as far as possible, a model which can be copied at home, particularly with regard to fire safety. This type of teaching activity may require additional space.

### Garage and Workshop

A well appointed maintenance unit for both equipment and vehicles is essential. So much potentially useful hospital equipment lies idle for the want of some small repair. A good workshop can also be used for the manufacture of items of furniture from locally available materials, avoiding the cost and difficulty of obtaining such things from outside.

garage design

The garage should have at least two maintenance bays each 6 x 3 m, one with an inspection pit. A stoutly made standing work bench should run along the wall at the end of the bays. It is useful if the roof construction is strong enough for a

block and tackle to be fitted for lifting out engines. The garage workshop and the general workshop can be combined and the size will depend upon the equipment to be housed. Most commonly, general woodworking benches with vices are the most useful with some provision for welding (Figure 50).

FIGURE 50  
garage and workshop

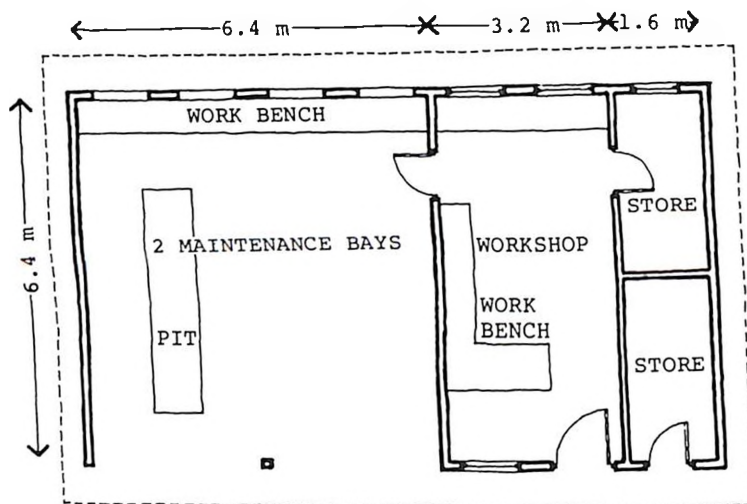

It is common to include in the maintenance block a large general-purpose store for bulk items such as building materials, gardening supplies and odd pieces of furniture and equipment. In any case a store for garage and workshop supplies is needed.

#### 4.8 HOUSING

ref 8

The design of staff housing is beyond the scope of this manual although it is a vital element in any hospital design, in fact it has been estimated that typically it accounts for up to 30% of the capital cost of a rural hospital. Housing is required for different levels of staff and specifications for each grade are usually laid down by the government ministry or agency concerned.

relatives' shelters

Besides accommodation for hospital staff, there should be some kind of shelter for the relatives who invariably accompany patients. It is usual to provide at least as many places for relatives as there are beds in the hospital. The shelters themselves can be as simple as possible, perhaps along the lines of the self-care wards in Figure 47.



## CHAPTER FIVE - BUILDING CONSTRUCTION

introduction



ref 8

In the context of diminishing natural resources and world shortages of money and materials, it is a significant fact that often over 80% of the cost of setting up a new hospital is spent on the buildings. It is central to the purpose of this manual to show that a smaller proportion of the health budget can be spent on medical buildings without lowering the quality of medical care. The principle that effective and acceptable medical buildings can be designed and built simply and economically is followed throughout this chapter.

### 5.1 BUILDING METHOD

local architecture

Having developed a building plan from the guidelines set out in Chapter Four, it now becomes necessary to decide upon a method of enclosing the space shown on the plans in the most efficient way. The best guide to an appropriate type of construction is to study other buildings in the area, for example, their shape, whether they have flat or pitched roofs, and the materials from which they are made. It is generally true that the further one deviates from the local architecture, the more money and time will be used in building. Other factors such as climate, use of materials and labour and maintenance are discussed later.



selection of construction type

It is recommended here that a form of rationalized traditional construction should be adopted. This method falls somewhere in between two extreme approaches. The first and much used is the prototypical standardized type of solution in which a building system is worked out and applied regardless of the local conditions, in which case the building cannot meet all the precise local requirements with respect to climate and topography, nor can money be saved by taking advantage of local materials and techniques. The other extreme is to consider each design problem completely separately and produce a wholly individual solution for each medical unit. This method, though time consuming, produces better results but is usually found unworkable due to lack of architectural manpower.

rationalized traditional construction

In rationalized traditional construction local variables are taken into account but are incorporated into the buildings in a systematic way, usually by designing within a building module such as described in Chapter Four. Further rationalization can be achieved if all factors, such as space standards, which are not subject to

page 33

prefabrication

local variation are standardized. Some examples of this type of construction are shown in Section Six of this chapter.

Great hopes have been held out for prefabrication as the means of providing inexpensive buildings quickly, but these expectations have not generally been realized in practice even in intensively industrialized nations. In the developing world there are some fundamental objections to industrialized building systems:

- they are capital-intensive relying on expensive machinery rather than manpower, whereas in most developing countries manpower is plentiful and capital is in short supply
- the necessary arrangement of a central plant dispatching manufactured building components to scattered sites is often not suitable where the transportation network is not highly developed
- the materials from which components are made and certainly the machinery used in their manufacture is generally imported from abroad
- prefabrication generally requires expensive handling equipment (cranes etc) on site which is beyond the resources of a small contractor.

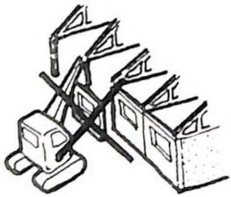

Prefabrication is not, therefore, recommended in this manual except for on-site prefabrication of such repetitive items as roof trusses, lintels, formwork and common joinery.

local materials

There is a cardinal principle to be applied in the selection of building materials, namely that local materials should always be preferred to imported ones. The reasons for this should be obvious, but nevertheless are often not appreciated:

- there is nearly always a saving obtained from using materials and equipment which do not include transportation charges or import duty in their price
- it is sensible to encourage the economy and employment situation of local districts by using goods of local manufacture
- local materials have the advantage that they can always be easily maintained or replaced
- the use of local materials can lead to a type of architecture which is in harmony with neighbouring buildings.

Set against these advantages are two important factors. The first is that many items needed in even the most simple construction, such as cement or roofing timbers, may not be locally produced. The second is the commonly held attitude

that certain materials (ceramic tiles, P.V.C. floors, etc) are 'suitable' for medical buildings whereas others (fairfaced blockwork, concrete floors, etc) are not. When dealing with situations of extremely limited resources, this attitude must change.

determining construction standards

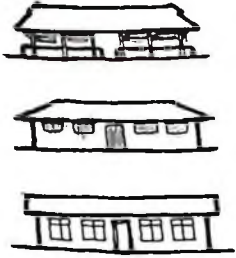

To begin with it is neither necessary nor desirable for all medical buildings to be built to the same standard, in fact some, including relatives' shelters and self-care wards, need satisfy only the basic requirements of soundness, durability and shelter from the elements. From this basic level of building a range of construction types of higher standard can be worked out to suit the function of each medical building. If this is done, following the rule that any higher standard can only be justified if it leads to the possibility of a higher level of medical care, then each building will be only of the standard that it needs to be and the best use will be made of the money and materials available.

## 5.2 CONSTRUCTION AND MATERIALS

Introduction

It is not the intention here to detail the many different building methods to be found in the developing world as there have been several books and manuals written on this subject. Rather a number of alternative construction methods and materials are considered for the main building elements, with notes on their suitability for different circumstances. With these notes it should be possible to make the best selection of materials and building method for a particular job.

ref 17

### Foundations

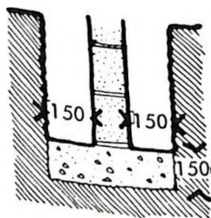

foundation walls

The most common type of foundation is a poured concrete strip footing where a trench is dug (usually 300 mm wider than the wall to be supported) to a depth where the ground is firm and undisturbed. The bottom of the trench should be square and flat and the sides vertical. The thickness of the footing should be equal to the projection beyond the wall or 150 mm, whichever is the greater.

In some circumstances cement may be prohibitively expensive or it may be difficult to obtain. In this case a burnt brick or stone footing can be used but the bricks must be laid up with a proper cement-sand mortar to avoid deterioration from moisture penetration. This precaution applies equally to foundation walls which are built off the footing but nevertheless are still below ground. These

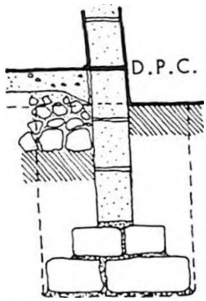

walls should always be made of durable materials jointed with good quality mortar and with a damp-proof course (D.P.C.) of bituminized felt, polythene or similar material running through the wall at the floor level. This last measure is especially important, as often more damage is caused by damp rising up from the foundations than from rain falling on the wall itself. The provision of an inexpensive D.P.C. can therefore add years onto the life of a wall even if it is constructed of 'impermanant' materials.

### Floors

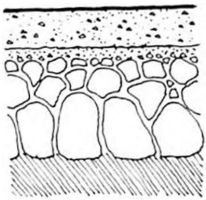

Most rooms will require a 75 mm thick concrete floor slab cast over a 225 mm layer of hardcore of stones or broken blocks with sand or ash bedding. In areas where the soil is stable or where there is very little rainfall, the hardcore can be omitted and the slab laid directly on well-rammed earth. For some rooms, such as the shelters for relatives or temporary accommodation erected in times of epidemics, a rammed earth floor will itself be quite adequate. It should be possible to trowel the surface of a concrete slab sufficiently smooth to use as a finished surface, bearing in mind that a too smooth floor can become dangerously slippery when wet. The finished floor level should always be at least 150 mm above the surrounding ground level to avoid moisture penetration.

cement screed

If the quality of workmanship is low, leaving a poor surface on the slab, then a sand and cement screed of no less than one inch thick can be applied to the slab. This is an expensive item, being rich in cement, and is liable to cracking if not properly laid; therefore it should be avoided wherever possible.

timber floors

Timber floors are susceptible to attack by termites and other insects and should not be used. The more expensive floor finishes such as thermoplastic tiles are unnecessary extravagances requiring maintenance and causing difficulties when replacement is necessary.

### Walls

earth walls

The simplest and most economical methods of wall construction are those using locally obtained earth either in the form of mud bricks or blocks, rammed earth or mud and wattle. All the advantages previously mentioned in connection with the use of local materials apply here. The disadvantages, of course, are lack of permanence and the relatively poor quality of internal surface. Both of these can be

ref 19

mitigated by applying a thin rendering of mud mixed with a binder such as cow dung to the surface and renewing it yearly. Regular whitewashing also has a preservative effect besides giving a clean and bright appearance. Common mud walls are amazingly durable in dry areas but in areas where heavy rainfall is experienced a generous roof overhang of at least 800 mm is essential. Where mud walls are reinforced with sticks they should be treated with Dieldrin or other preservative either directly or by adding it to the water when making the mud. This will ensure that termites do not destroy the wall by eating away the internal wood skeleton. Alternatively local timber such as mangrove, which is not susceptible to attack, might be obtainable. These earth forms of construction are indigenous to vast areas of the world and should not be rejected out of hand for some hospital buildings such as the shelters required for relatives or self-care wards.

swahili construction

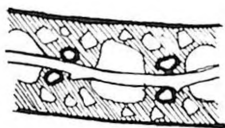
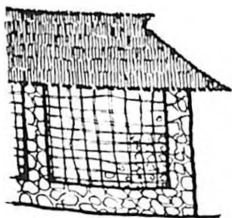

Many regions have highly developed traditional building methods appropriate for medical buildings such as the Swahili type of construction found along the coast of East Africa. In this method a lattice of mangrove poles is erected into which fist-sized stones are pushed. The small gaps between the poles and stones are then filled in with mud with a final layer of sand-lime rendering on the outside. This gives a very sturdy building with the two added advantages that termites do not attack mangrove poles and a high quality surface can be obtained because plaster adheres well to the stone chippings projecting from the mud. Of course this type of method can only be adopted where the technique is commonly used for other buildings.

burnt brick walls

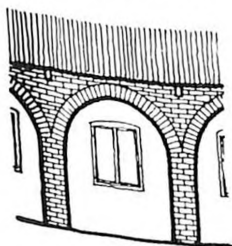

ref 20

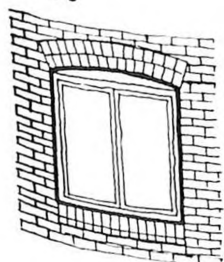

A great improvement on the above are burnt clay bricks which combine the good qualities of mud bricks with permanence and greater structural strength. The two prerequisites are a good supply of firewood or other fuel and clay of a suitable quality. By-product fuels such as coffee husks and sugar cane waste have been used successfully and should be investigated where more traditional fuels are in short supply. Clay containing one part in five of sand is ideal and this kind of mixture can often be found about half a metre below the surface in river valleys and plains. Although not difficult, brick making requires that the proper procedures are followed carefully and technical literature should be consulted. Brick is one of the most attractive and versatile building materials if skill in laying is available. Not only can it be used for plain walling, but also for columns, window cills, vaults and arches, obviating the need for expensive reinforced concrete lintels and metal cills.



stone walls

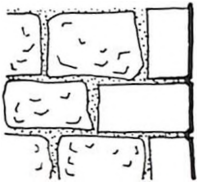

Natural stone is an excellent building material being permanent and attractive with a hard surface giving good weathering properties as well as having the same capabilities as brick for forming arches and cills. Cost and availability are the only obstacles to its use although, if there are local quarries, semi-dressed stone will probably be cheaper than concrete block.

concrete block walls

Concrete block work has become the standard solution to low cost wall construction although it cannot compete pricewise with the indigenous methods mentioned above. It relies entirely on the availability of cement, not only for the blocks but also for the bonding mortar. Cement which besides being expensive may in some cases be unavailable. Concrete block provides a sound wall although by itself it is not waterproof. This can be overcome by rendering the outside surface with a layer of sand-cement render of at least 10 mm thickness.

wall protection

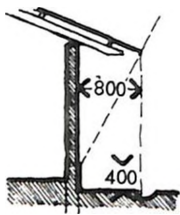

Alternatively a plain wall can be protected from rain by a generous roof overhang or verandah with the base of the wall up to 400 mm above the ground painted with bituminous paint. It is important to note that there is no appreciable difference in the rate of rain penetration between a 150 mm thick wall and one of 200 mm making the former the better choice unless structural requirements dictate a greater thickness.

plastering

Where the craftsmanship is of a high enough standard, it is recommended that plaster be omitted as an internal finish bearing in mind that for a fully plastered wall half the cost of the wall goes into the plastering. A reasonable substitute is a wash of sand and cement brushed on to fill up the small cavities in the blocks which costs less than one third the price of plaster. The wall can then be finished off in most cases with whitewash or with one coat of emulsion and two coats of gloss paint where a high quality washable finish is required. From an aesthetic point of view, block work is rather dull and often out of sympathy with more traditional buildings unless it is rendered and lime-washed on the outside.

brick and block laying

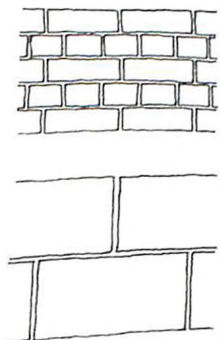

Burnt brick and stone walls should preferably be laid with cement mortar but if this is not available, mud mortar can be used instead without losing too much strength. The reason for this is that the elaborate bonding of brick and stone walls gives the wall a natural stability which is not so dependent on the strength of the joints. Concrete block walls on the other hand, depend more on good quality joints and should always be laid with cement mortar. In any case there is less to be saved by economizing on mortar where it only accounts for less than 10% of the wall whereas in brickwork it can be as much as 30%.

#### timber walls

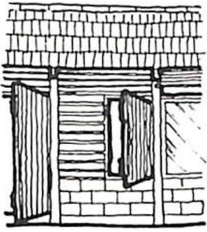

Timber walls are often not favoured because of their vulnerability to attack by termites. This need not be a deterrent where timber pressure impregnated with preservative can be obtained or where there are local species of wood that are not susceptible to attack. Timber combines high strength with lightness of weight and simplicity of construction and is ideal in hot, humid climates where large areas of ventilation can be gained by the use of louvres and shutters. It also lends itself to on-site prefabrication of wall panels, roof trusses, etc which can speed up the building process.

#### corrugated iron walls

Corrugated iron has been extensively used for walls, being speedy to erect and effective in keeping out the rain. Its chief disadvantages are its very poor thermal insulation qualities, its need for regular repainting and the fact that it is usually manufactured from imported materials, which means it may become increasingly expensive. It has however frequently been used for temporary buildings in which a lower standard of construction can be more easily accepted. Such buildings often fulfil a useful purpose for a number of years before they are replaced and even then the corrugated iron sheets can be carefully removed and reused for roofing a more permanent building.

#### Roofs

#### thatched roofs

Thatching, whether of grass, reeds or palm leaves, can be compared to mud walls in terms of suitability. It has the same advantage of minimal cost and can always be erected, maintained or replaced with local materials and labour. The permanence of thatch depends very much upon the workmanship and type of thatch used. A well laid roof of papyrus reed can last for more than ten years. Again a good indication is to look at the quality of workmanship and materials on neighbouring buildings.

Thatching has further advantages of good thermal insulation and lightness of weight, the latter allowing the supporting structure to be extremely simple, and to consist of wooden poles or bamboo for example. On the other hand, thatch can harbour insects or even snakes, there is some risk of fire and some leakage may occur in heavy rain but, as with mud walls, the thatched roof is quite suitable for ancillary hospital buildings.

#### corrugated iron roofing

Of the sheet roofing materials, corrugated galvanized iron, (c.g.i.) is by far the most common although by no means the most effective. As with other sheet



asbestos cement roofing

materials, an orderly support structure is required with preferably a simple rectangular roof shape to minimize cutting and wastage. The roof structure can be light being more determined by the weight of a person maintaining the roof than the weight of the covering material. Some roof truss designs are shown later in Appendix Three.

The reasons for the wide spread use of corrugated iron is that it provides the cheapest 'permanent' roof, it is light to transport and handle in construction and requires little skill to erect. Against this, it is becoming increasingly expensive, it requires some maintenance in the form of painting to retard rusting, it has virtually no thermal insulation value and is very noisy in heavy rain. These last two points can be largely overcome if some form of ceiling is installed although this of course increases the cost considerably.

In terms of performance, asbestos cement sheets are superior in almost every respect, particularly in that they are completely maintenance free, have some insulation value and are quieter in heavy rain than corrugated iron. The main disadvantage is cost, which is usually higher than corrugated iron, and availability which depends much more on the manufacturing capacity of the country. They also are heavier, requiring a more substantial support structure and needing more skill in construction if costly breakages are to be avoided. Breakages are also common in transit over the poorer roads serving rural areas which means that when ordering it should be made clear that only whole, undamaged sheets will be accepted on-site. If it is available and can be afforded, asbestos cement sheeting should always be preferred to corrugated iron for medical buildings.

aluminium roofing

In some areas aluminium sheeting is used but it is usually more expensive than iron sheeting without very much improvement in performance. The rust-proof quality of aluminium is somewhat offset by its tendency to corrode by electrolytic action with the alkali component in the concrete or cement mortars used to fill in between the top of the wall and the roof sheeting. If this is guarded against by separation or coating the vulnerable surface with bitumin, then aluminium is virtually maintenance free. Aluminium is considerably superior to corrugated iron and comparable with asbestos thermally in that it not only reflects sunlight, but is fairly low in its emission of the heat which it does absorb.

ref 30

tile roofs

Tiles and slates of clay or concrete make a durable and attractive roof and although they are heavy and therefore require a substantial supporting structure

ref 27

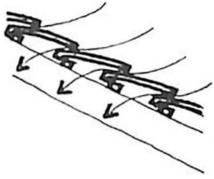

they are not necessarily expensive. Recent studies in Kenya have shown that several types of locally made tiles can compare in cost with c.g.i. sheeting, even allowing for the additional cost of the supporting structure. Concrete tiles have a poor insulation value whereas clay tiles are better insulators. The latter should however not be used without a ceiling where the nights are cold in that the open nature of a tile roof allows cold air to penetrate the building and after rain considerable discomfort can result from evaporative cooling.

shingle roofs

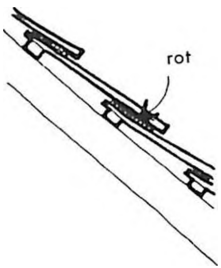

Shingles are lighter in weight than tiles and can form a good roof if properly laid. If cedar is available no treatment is necessary, but if poorer quality wood such as cypress is used, the shingles should be impregnated by prior soaking in motor oil to increase their resistance to water. The periodic re-oiling of shingle roofs serves little purpose in that wet rot usually sets in between the overlapping pieces where water is retained after the rest of the roof has dried out and where the oil will not penetrate.

roof design

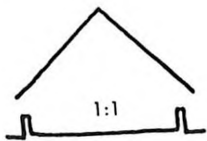
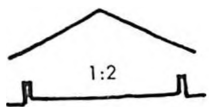
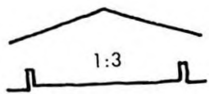
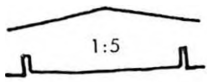

The overall shape and slope of the roof is as important as the choice of materials. The standard pitched roof with gable ends is the common solution due to its simplicity of construction which allows for sheet materials to be used without cutting and for economical roof trusses to be used for the supporting structure. The critical design consideration is the slope of the roof which is in turn determined by the covering material. As a general guide the following minimum slopes should be adopted:

- single sheet c.g.i. with sealed ridge flashing 1:5
- overlapping sheets of c.g.i. 1:3
- concrete and clay tiles 1:2
- timber shingles 1:1
- thatching 1:1

If the walls are of concrete block, the roof slope should be such that there is a minimum amount of cutting of the blocks where the gable wall meets the underside of the roof. In this respect a slope of 1:3 gives the best results.

ref 26

mono-pitch roofs

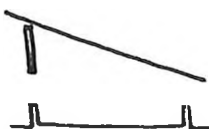

A mono-pitch or lean-to roof is suitable for small spans of about 3 m having the advantage that if a single sheet is used it can be laid almost flat (say 1:10). Large spans are less satisfactory because it is difficult to use a truss for the supporting structure and the pitch of the roof must be steeper because a single roofing sheet can no longer be used. Furthermore a steep slope on a mono-pitch roof



tends to create a high wall on one side of the building which is difficult to shade and wasteful in material.

hipped roofs

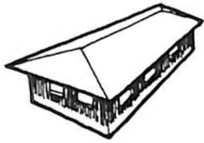

Hipped roofs are more difficult to construct as they involve special rafters and cutting of the covering material. They also limit the expansion of the building in the long direction. A hipped roof does however save money in the masonry work by cutting the wall area to a minimum and also it gives what many people consider a friendly appearance.

Other more exotic roof shapes such as domes and vaults are not considered in this manual but can be appropriate where they form an indigenous part of the local architectural culture and in these situations their use is to be encouraged.

### Ceilings

In climatic regions where either the nights are cold or the days very hot, then the installation of a ceiling is essential particularly if the roof covering has poor insulating qualities. It is also desirable to have a ceiling where extreme cleanliness is required such as the theatre and laboratory, although in most hospital rooms, including the wards, ceilings are not necessary from a functional point of view. In fact ceilings can present a considerable nuisance in that they provide excellent breeding grounds for insects, birds and bats, which in turn can create extremely unpleasant odours and a generally unsanitary situation. Ventilation openings should be well screened and bats can be deterred by allowing some light into the ceiling space. The omission of ceilings wherever possible is a sensible and worthwhile way to economize bearing in mind that the incorporation of a ceiling will add about 50% to the overall roof cost.

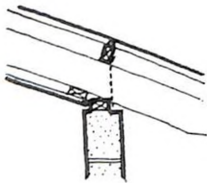

ceiling materials

In paramedical buildings, if ceilings are needed for insulation, traditional local materials such as bamboo, papyrus or split sisal poles can be used, but such ceilings tend to harbour vermin and are therefore inappropriate for medical buildings. Where a sealed ceiling is required, softboard or expanded polystyrene is the common answer, polystyrene having approximately 60% higher thermal insulation value.

softboard and polystyrene ceilings

Softboard of 12 mm thickness is fairly robust and usually available, but can be attacked by termites and is susceptible to mould in damp climates. Polystyrene of 19 mm thickness is a far better insulator, is cheaper and unaffected by moisture.



or insects. It does however require careful handling both in transit and construction to avoid chipping or cracking, but has the advantage that if care is taken to keep the surface clean, it needs no painting. If painting is necessary then P.V.A. emulsion must be used whereas a simple lime wash can be used on softboard ceilings.

hardboard ceilings

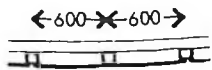
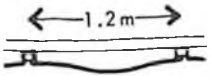

Hardboard of 3 mm thickness is the cheapest ceiling material which still gives a good quality paintable surface. It is often seen sagging badly due to the too wide spacing, usually every 1.2 m, of the supporting battens. This common mistake arises from the fact that when hardboard is new it has considerable stiffness giving a false impression of strength. It loses its initial rigidity after some months, particularly in humid climates, causing the ceiling to bulge downwards. The simple remedy is to ensure that the ceiling battens are spaced no wider than 600 mm apart in both directions. Hardboard is a poor insulator and varies a great deal in quality, some types being nothing but improved cardboard and quite unsuitable for any building purposes. The better qualities have a first class surface and are less susceptible to deterioration by moisture than is, for example, softboard.

plaster ceilings

Plaster ceilings are excellent from a performance standpoint, but they are costly and difficult to execute and therefore rarely seen in remote areas. Similarly, corrugated iron ceilings with an earth backing, although having the advantages of durability and good thermal and sound insulation are little used today in this case because of their great weight and poor appearance.

### Windows and Doors

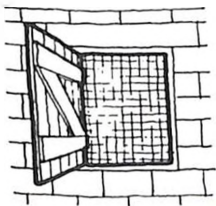

The simplest and probably most common type of 'window' in rural areas is a timber framed unglazed opening with 50 mm steel mesh burglar proofing, if necessary, and a side hung wooden shutter. It is a cheap and effective solution for many hospital buildings including kitchens, laundries, and even wards and offices except in areas where climatically it is unacceptable, for example, where it is cool during the daytime.

insect proofing

Insect proofing is essential to some spaces such as the theatre and laboratory and in some regions may be desirable for all rooms. The choice of material between galvanized metal and nylon mesh will depend upon cost and availability as both deteriorate, the former by rusting and the latter under the effects of ultraviolet

light. Any type of insect mesh tends to cut the free flow of air through an otherwise open window and this should be taken into account when estimating the area of ventilation needed.

timber windows

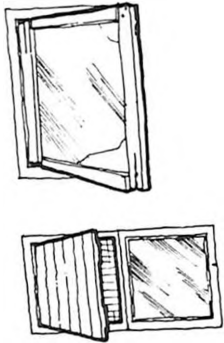

Timber framed glazed windows attempt to combine natural lighting requirements with variable ventilation, but in most cases they are unsatisfactory. The main problem being that for the small wooden frame around the opening part to hold the glass properly for a number of years, it requires well seasoned and preserved wood and expert joinery. Otherwise the joints will open and eventually the glass will break. A recommended alternative is a combination of the above with the glazed areas permanently fixed and so not liable to deterioration, and ventilation achieved by separate wooden shutters or louvres over unglazed openings.

steel windows

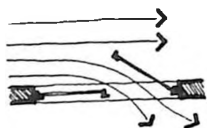

Metal casement windows are widely made from standard steel sections and provide a long lasting window as long as the metalwork is painted approximately every five years. Casement windows are quite effective ventilators being capable of scooping air into the building provided they open the right way, although there is no vertical control of air movement and the often large, fixed panes cut down the total openable area. If the panes are small, the cost of replacing broken glass is minimal and there is no need for separate burglar proofing, as long as the latches are secure. Casement windows are often made locally and inexpensively from standard sections, but the quality should be checked before ordering.

louvre windows

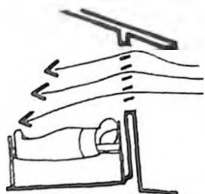

The adjustable louvre window has gained in popularity for medical buildings due to several factors. Firstly, it is inexpensive (cheaper than the factory made metal casement); secondly it not only gives variable ventilation up to almost 100% open but also allows the direction of the breeze to be controlled; and finally any width of opening can be used by simply cutting the glass louvre blades to the correct length. The objection to louvres, that they are more difficult to burglar-proof, does not apply in many hospital buildings and in any case, bars can be incorporated horizontally between each louvre. One further advantage is that where ventilation is required, but not light, say in the lower part of examination room windows, the glass louvres can easily be replaced by an opaque material such as asbestos or the glass panes can simply be painted white.

doors

For external and internal doors a well made ledged and braced door is usually the best solution being cheap, durable and capable of local manufacture. Flush doors are not recommended because the lower priced types which can compete with

ledged and braced doors are susceptible to impact damage by trolleys, etc and tend to disintegrate under harsh climatic conditions being held together entirely by glue. Panelled doors are attractive but require a high level of craftsmanship; if this is available then a panelled door is a good choice for main entrance doors.

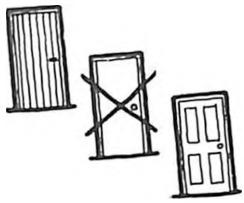

Many different widths of doors both single and double are found in hospitals, but in fact there need only be two types: those which, for any reason at all, a bed or stretcher may need to be taken through and which must be 1.1 m wide, and those which will never have to accommodate a stretcher and which need only be 800 mm wide. Double doors are not generally recommended except in places where they will remain open most of the time, as they are vulnerable to damage and are more difficult to use. Doorways also have an important ventilation function in that they can, if well placed, provide the low level ventilation necessary in hotter areas. Doors with separately hinged upper and lower sections are extremely versatile for both light and ventilation and deserve to be more extensively used.

door openings

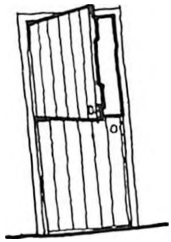
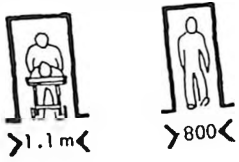

### 5.3 MAINTENANCE AND IMPROVEMENT

maintenance policy

An important factor in the selection of building materials is their expected performance during the life of the building. It should go without saying that, in considering material costs, the ongoing or maintenance cost should be taken into account as well as the initial price. It has been the situation for a number of years in industrialized countries to accept high initial costs for sophisticated, highly durable materials in the expectation that maintenance costs will be minimized. In developing countries this practice can be challenged and possibly reversed. Where capital is extremely limited and imported materials are even more expensive than in their country of production, and where there is considerable unemployment in rural areas, it makes better sense to use lower cost local materials, the maintenance of which will provide much needed employment.

maintenance vs replacement

A clear distinction should be drawn between maintenance which is labour intensive and replacement of worn out elements which is capital intensive. In the latter case, it is far better to add say 25% to the cost of a roofing material, which anyway will add only 5% to the total building cost, than be faced with replacement costs within a few years which, due to inflation, are likely to be considerably greater than the initial cost of a more durable material.

## improvability

It follows from the above that materials should be chosen which have a long life even if they require some maintenance during their lifetime. This particularly refers to the main elements of the building, the floors, walls, roof etc, where extra investment is really worthwhile. It is better for a given amount of money to spend more on the superstructure and save on finishes which are often not necessary, but which can in any case be added or improved at a later date. The principle of improvability is basic to economic building where, due to lack of funds, buildings must often be constructed in the simplest possible way initially.

### insect and fungal attack ref 21

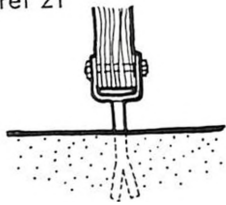

One important factor affecting the durability of buildings in tropical countries is the deterioration of timber due to insect or fungal attack. Insect attack comes mainly from termites and various wood boring beetles, and can be counteracted by design considerations such as isolating all timber components from the ground with metal termite shields or, preferably, by treatment of the timber with some kind of preservative.

### timber preservation

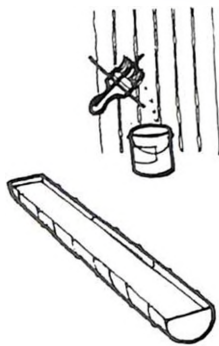

Preservatives can be applied in a number of ways of varying effectiveness. The mere painting of the timber with preservative is almost totally ineffective and should not be accepted; the alternative on-site method of immersing the timber for 24 hours in a bath of preservative is more efficient and acceptable where no better alternative is available. Timbers should be immersed after all cutting has been done to ensure that the preservative soaks well into any exposed end grain. The best method, however, is to purchase timber pressure-impregnated at the timber yard; this method is fully effective and although such treatment facilities are available only at main yards, it is worth paying the likely transportation surcharge to obtain it.

### insecticides

ref 8

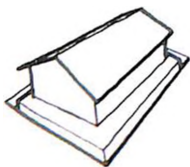

A further precaution that can be taken, particularly against termites, is to poison the soil beneath and immediately surrounding the building with a solution of Dieldrin. In practice this means treating the foundation trenches and all the ground upon which the building will stand with  $4\frac{1}{2}$  litres of 0.3% Dieldrin emulsion per square metre raked in to a depth of about 150 mm. Further protection can be gained by digging a 400 x 400 mm trench around the building and treating it with the same solution at a rate of 2 litres per metre and then replacing the soil in the trench and treating it in the same way. This latter practice, although effective, should not be followed where there is a danger of poisoned ground water running off into nearby streams or wells. The life of mud and wattle, and sun-dried brick buildings can be extended by using a similar solution of Dieldrin in place of plain water in the mud making process.

fungus

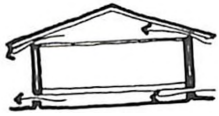
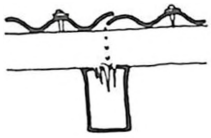

timber seasoning

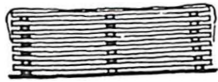

fire

Fungal attack only occurs in timber with a relatively high moisture content (over 20%), usually caused by inadequate curing of timber in the first place or by the timber coming into contact with a source of moisture within the building, for example, where a roof timber is lying directly under a crack in the roofing material. It can also occur in damp areas such as floor or roof spaces which are not ventilated sufficiently to keep the timbers dry. Fungal attack, which usually shows in the form of mould, can be counteracted by avoiding the use of unseasoned timber and not allowing the type of conditions described above but as with insect attack, the most effective defence is to build only with pressure impregnated timber.

The seasoning of timber on site is a simple procedure requiring only that the timber be ordered 2-3 weeks in advance of its use in the building. It should then be stacked in such a way as to allow air to circulate around each board and, of course, it should be protected from the rain.

Finally the danger of fire in timber buildings or building components is often feared. In single-story buildings this fear is generally unfounded so long as the burglar-proofing does not prevent escape in case of fire. It is also often the case that the furnishings within the building, particularly foam cushions and mattresses cause death by smoke inhalation long before the fabric of the building catches fire. Nevertheless it may be prudent to use a timber preservative containing a fire retardant. Fire-retardant paints are expensive and not very effective. Some local timbers are particularly fire resistant and any timber of larger cross section (say more than 100 x 100 mm) will resist fire for a considerable time.

#### 5.4 LABOUR AND SELF-HELP

Great use has been made in many places of the principle of self-help especially in the building of medical units. This is usually confined to the fund raising and organizational aspects but can be extended to encompass the construction process itself. The simplest and frequently most useful contribution that can be made is in the manufacture of building materials such as concrete blocks or bricks. It should be borne in mind that of necessity the helpers will be inexpert in building matters and therefore in an operation where quality control is of utmost importance a good deal of time must be allowed for supervision.

self-help construction

If self-help methods are to be used in the actual construction, thought should be given as to which particular tasks lend themselves to unskilled labour. For example, it is easier to build secondary walls using self-help manpower if the main



walls and roof have been soundly erected by a contractor. In this connection the supply of self-help labour may be somewhat sporadic; this means that if the basic shell of say a new clinic building is quickly contractor built, it can be put into use while the secondary walls and windows etc can be completed at a more leisurely pace on a self-help basis. Besides the potential cost savings that can accrue from self-help methods, they are an important feature in encouraging local involvement. On the other hand if self-help labour is misused, on abortive work for example, it will have the reverse effect.

## 5.5 CLIMATE

The effect of climate on building construction and materials is as complex as it is acute which makes generalized statements difficult and possibly misleading. Meteorological data should be consulted as well as local statistics and experience.

ref 30

roof design

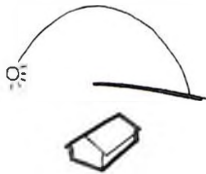

The key building component for thermal comfort in all tropical areas due to the high arc of the sun is the roof itself. A lightweight roof is unlikely to provide a comfortable environment in hot or cold climates unless the external surface is reflective, and insulation in the form of a ceiling is incorporated on the underside. In this respect it has been shown that there is no thermal advantage to be gained by increasing the height of the ceiling, and there is little advantage in ventilating the roof space. This is because in both cases the heat being transmitted is radiant and is little affected by the amount or temperature of the air between the source and recipient surface. This being the case, it is virtually as effective for the ceiling to follow the roof slope as it is to construct what may be a more expensive horizontal ceiling. The ceiling material should be chosen with thermal insulation in mind as well as the criteria already discussed in Section Two of this chapter.

page 92

roof shape

The overall shape of the roof can also affect the level of comfort inside the building. A steep roof is cooler than one of shallower pitch because the roof presents a sharper angle of incidence to the sun's rays. If a gable roof is used, it allows for high level ventilation in the end wall which can have a beneficial cooling effect. On the other hand, a hipped roof with a good overhang at the eaves gives effective shading to the walls on all sides of the building. These factors should be weighed with the general considerations for roof shapes in Section Two of this chapter.

page 91

### heavy walls

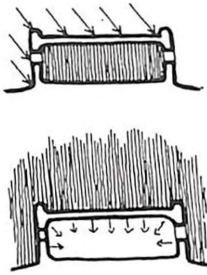

There are two approaches to the design of walls to meet different climatic conditions. The first is to build heavy walls of materials with a high thermal capacity such as brick or concrete block. (The thermal capacity of a material is the extent to which it can absorb heat per unit volume and is proportional to the density of the material). This type of construction is suited to places where the days are hot and the nights cold such as desert or highland areas with generally low levels of humidity. In these situations the heavy walls absorb much of the sun's heat during the day preventing the inside of the building from heating up rapidly and then at night, when the air temperature drops, the walls emit their heat keeping the rooms warm.

### lightweight walls



The second type of wall is one made of lightweight materials such as timber or open blockwork which have a low thermal capacity. This kind of wall is suitable where the days are hot and the nights are only a few degrees cooler, in which case the structure of the building soon loses the heat it has absorbed during the daytime allowing the maximum benefit to be obtained from whatever drop in air temperature occurs at night. It is also desirable to have a high standard of ventilation so that the cooler air can pass easily through the rooms.

### solar protection

Whatever the wall construction, it is important to shade as much of the wall area from direct sunlight as possible by providing a generous roof overhang (800 mm minimum for a wall of normal height). Glazed window openings are particularly vulnerable in that the glass allows the shortwave solar radiation to enter but prevents the lower temperature longwave radiation to leave the building creating what is commonly known as the 'greenhouse effect'. Windows can be shaded by canopies or blinds, the latter being more efficient if placed on the outside of the glass.

### verandahs



The verandah is an architectural device of great value as shown by its extensive use in traditional buildings in tropical countries. From a climatic point of view, it provides shading for the whole of the main wall of the building and cuts out a large amount of the sky glare which can be a major source of discomfort. Whatever the wall or roof design, the advantage will be lost if the main faces of the buildings do not face north and south.

### effect of climate on materials

Finally climatic conditions can have an adverse effect on building materials. Changes in temperature, for example, cause expansion and contraction of materials which, over a long period, especially if the changes occur quickly as after

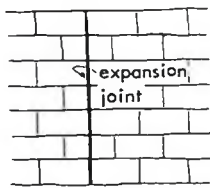

ultraviolet deterioration

the cooling effect of rain, can cause cracking in rigid walls or roofs. Equally serious can be the expansion and contraction caused by wetting and drying action following rain which often causes serious cracks in concrete blockwork. Apart from protecting the walls from the sun and rain by an overhanging roof and the inclusion of a D.P.C., cracking can be prevented by allowing frequent vertical expansion joints (about every 2-3 m in concrete blockwork) in the wall material.

The ultraviolet content of solar radiation can cause chemical changes in materials resulting, for instance, in the rapid deterioration of bituminous products. For this reason asphalt roofs should be protected from direct sunlight by light coloured stone chippings, aluminium paint or even a coat of lime-wash. Paints deteriorate more rapidly when exposed to solar radiation since this is liable to cause the breaking down of polymerization and loss of plasticity which causes cracking and flaking.

### 5.6 CONSTRUCTION EXAMPLES

In order to give some idea of the kind of construction that might be appropriate for rural medical buildings, two types are here described in greater detail. Each method has been designed bearing in mind the design considerations set out in Chapter Four and the principles of economical building outlined in this chapter. As with the design proposals, these methods of construction should not be indiscriminately copied. Apart from climatic and material differences between one place and the next, there may also be special factors such as earthquake conditions which must be taken into account.

FIGURE 51  
masonry type

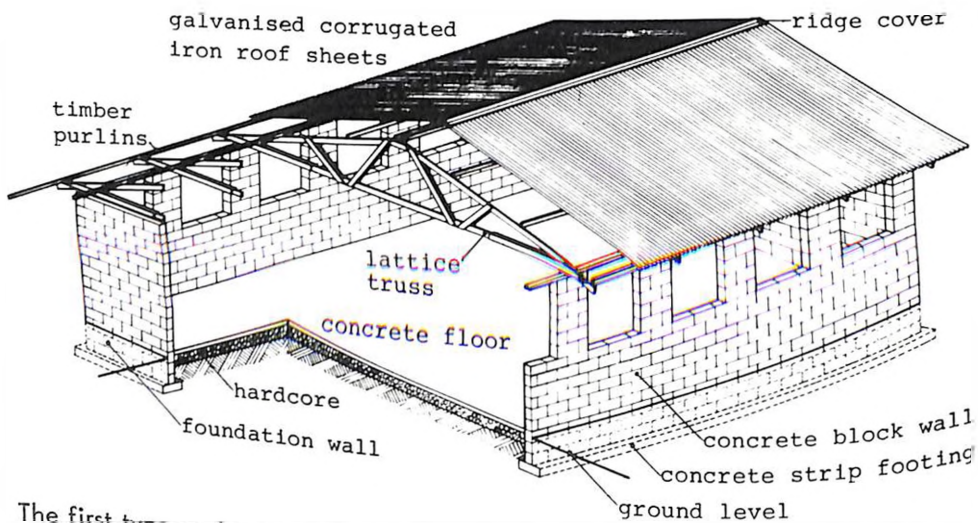

masonry type

The first type as shown in Figure 51 uses solid walls of, for example, brick or concrete block which would be suitable in moderate climates or where the days are



hot and the nights cold. It also depends upon the availability of masonry materials and probably requires a contractor to do the bulk of the work.

FIGURE 52  
column type

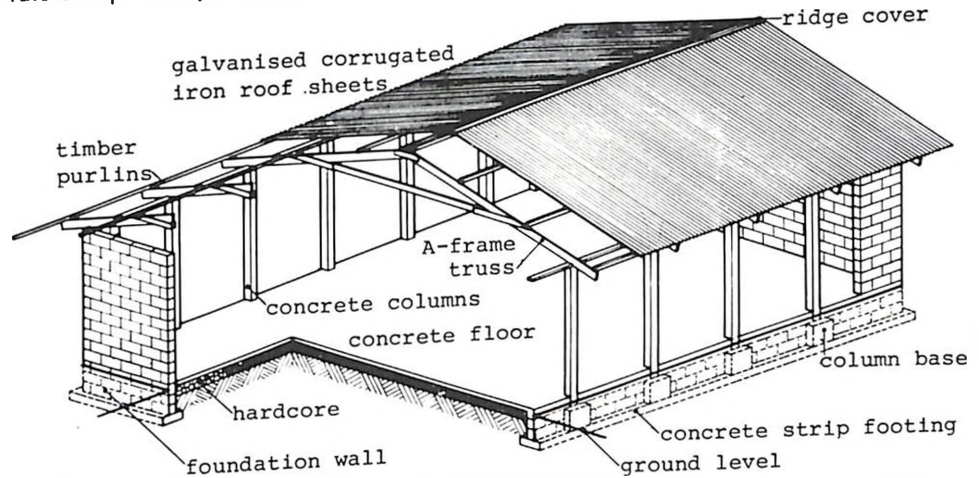

column type

The second type as shown in Figure 52 uses a basically open method of construction with concrete or timber posts to support the roof and non-structural infill walls between the columns. This method is better suited to climates with little difference between day and night time temperatures in which case the spaces between the columns can be filled in with lightweight screens of wood or reeds etc, allowing maximum ventilation. This type is also suitable where an element of self-help is anticipated in that once the columns and roof are erected all the walls can be built by self-help labour using local materials. Of course both types may be used for different buildings in the same hospital.

FIGURE 53  
verandah type

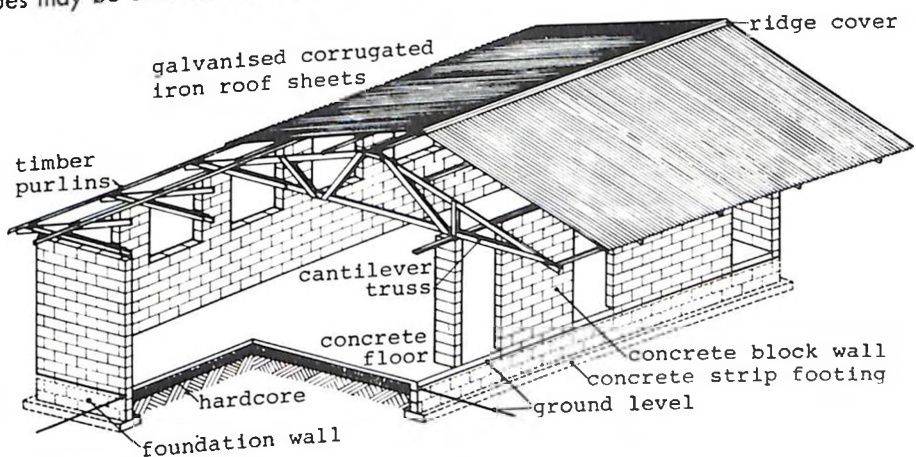

verandah type

Both illustrations show a 6.4 m wide block which would be suitable for many medical buildings including wards. The shell of the building only is shown to give an idea of the minimum amount that can be built initially at a very low cost. Figure 53 shows a variation with a 4.8 m wide building and 1.6 m verandah, which would be more appropriate for outpatient buildings where the rooms are smaller but generous covered waiting areas are needed.

FIGURE 54  
masonry type showing a  
lattice truss

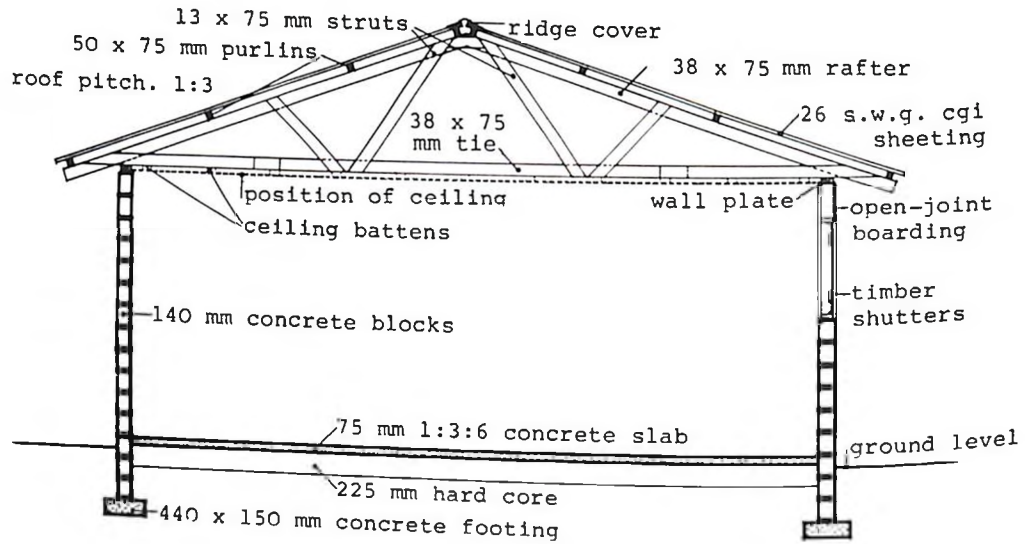

FIGURE 55  
column type showing an  
A-truss

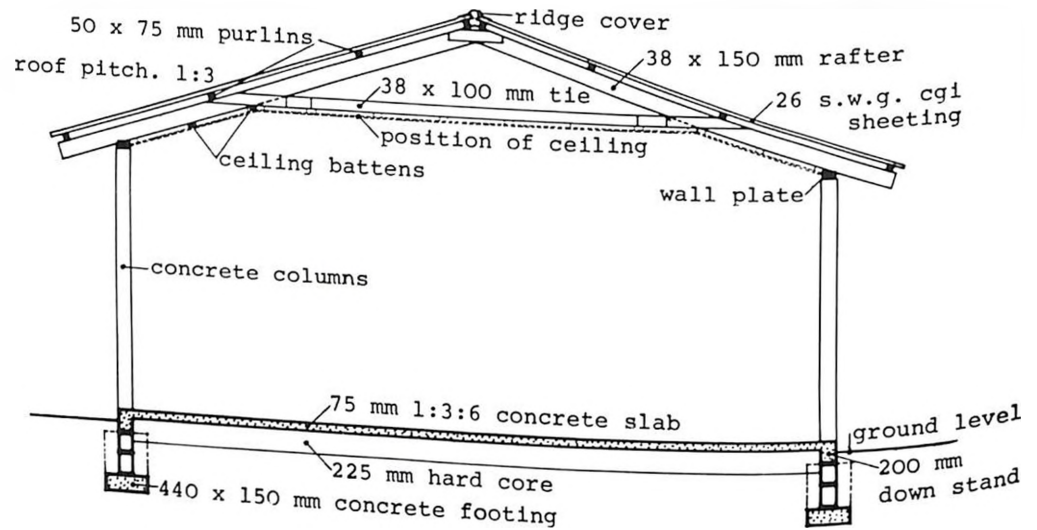
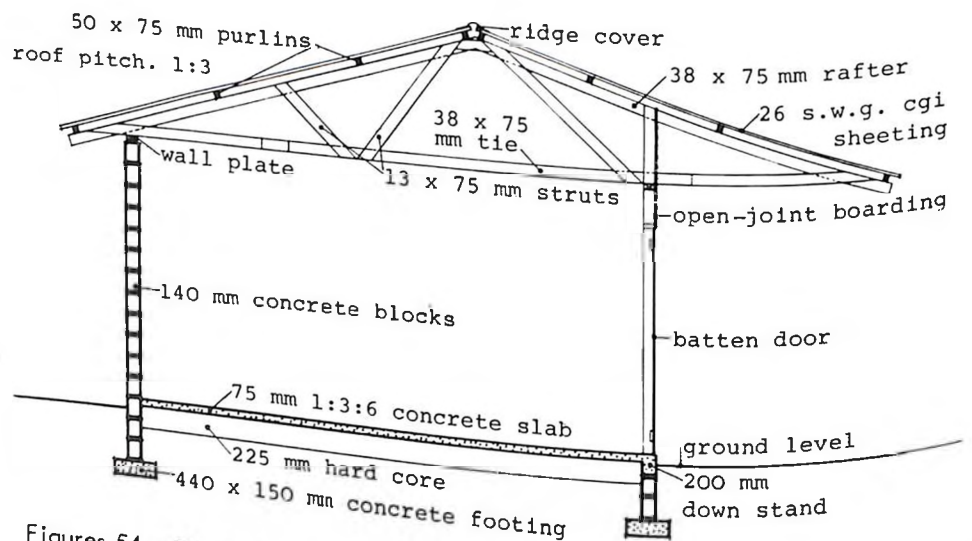

FIGURE 56  
verandah type showing a  
cantilever truss



sections

Figures 54 - 56 are cross sections through the building showing the constructional details and, in particular, how the roof truss design can be varied according to the type and size of the room. The A-frame truss in Figure 55 has the advantage



that for a given external wall height, the ceiling of the room can be about .4 m higher which makes it ideal for large uninterrupted spaces such as wards. The lattice truss on the other hand (Figure 54) uses about the same amount of timber but is better adapted to cover smaller rooms which require flat ceilings (to avoid cutting the tops of partitions) or where part of the roof extends outside the building to form a verandah as in Figure 56.

trusses

The trusses have been designed for maximum economy and ease of fabrication. The A-frame truss is easier to make but requires joints of good quality because if any one of them fails the whole roof may collapse, also it uses fairly large timbers (38 x 150 mm rafters). The lattice truss is more complicated to make but due to the greater number of members and joints it can tolerate lower grade timber and some poor joints without failing. Also the timbers themselves are smaller in cross section (38 x 75 mm rafters) which may make them more easily obtainable. Economical and tested designs for both types of truss are shown in detail in Appendix Three.

page 138

infill walls

The question of how best to fill in the openings left in the main structure produces several alternatives. Figure 57 shows a masonry wall with two different window solutions. The first is a simple timber shutter over an unglazed opening with permanent ventilation above. Adjustable glass louvres can replace the shutter either initially or as an improvement at a later date. The second is similar but narrower with additional fixed ventilation below the cill for areas where low level ventilation is desirable.

FIGURE 57  
windows in masonry type

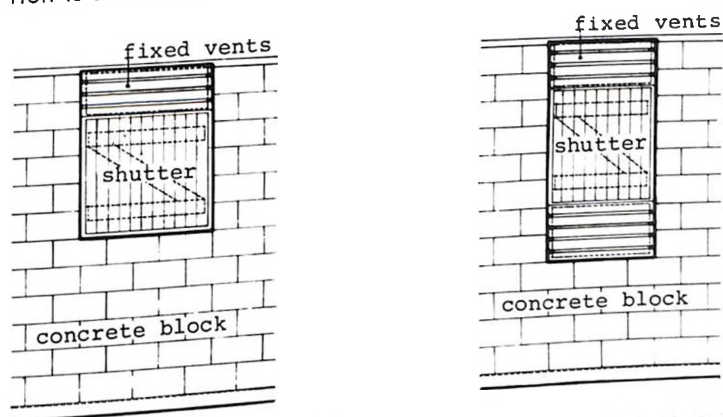

openings

Figure 58 shows the open type of structure which can be infilled in a great variety of ways including very simple traditional methods, such as mud and wattle, which can be executed by self-help labour. The first example shows a small shutter with fixed ventilation above, set in a mud and wattle wall. The second shows a larger area of both variable and fixed ventilation, again with the alternative of timber shutters or glass louvres for the openable part.

FIGURE 58  
windows in column type

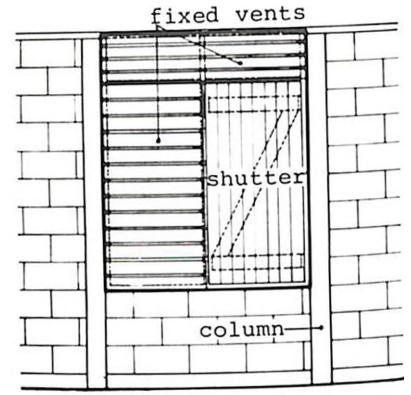
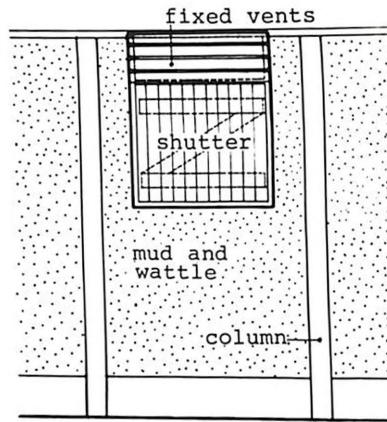

details

Figure 59 shows two alternative detail sections through the outside wall of a building. These are the kind of drawings from which a contractor could construct the building. They incorporate many of the guidelines mentioned earlier in this chapter such as the inclusion of a D.P.C., a drop of 150 mm between the floor and ground levels and the provision of insect screening to the eaves.

FIGURE 59  
detail sections

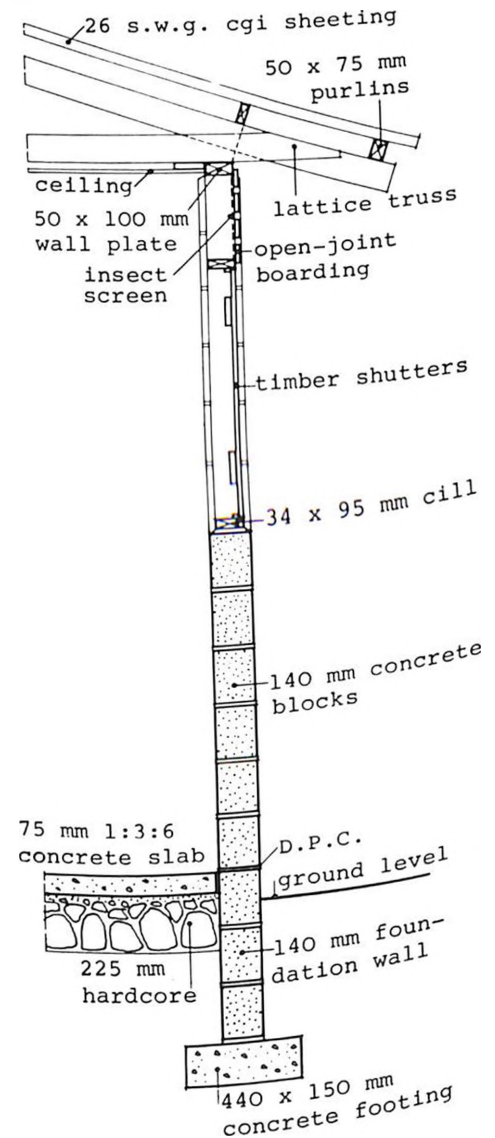
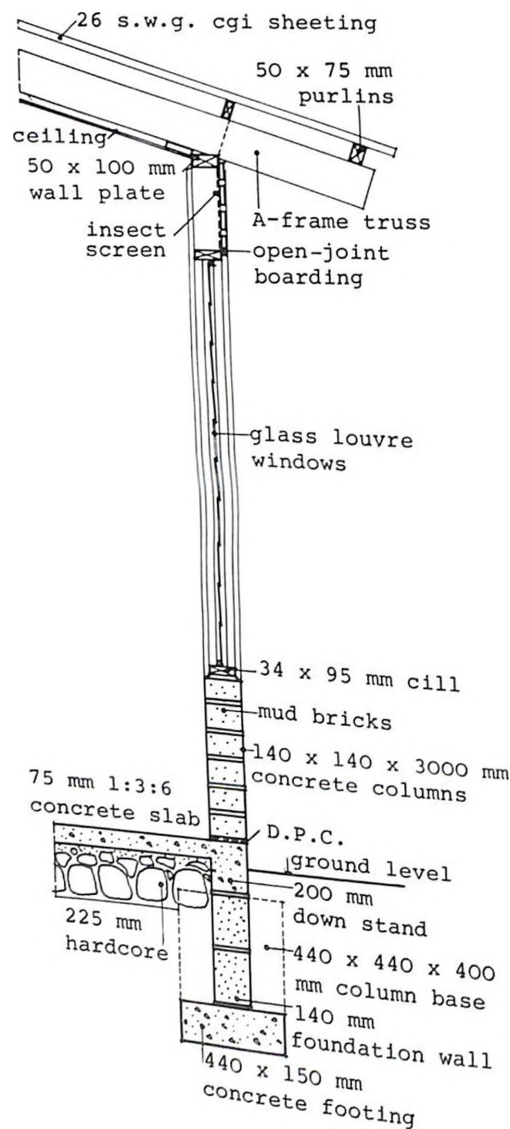

## CHAPTER SIX - BUILDING SERVICES

introduction

Medical buildings are great consumers of water and sanitary services and their proper provision and design is critical to the health and well-being of the patients and staff. Because of this there are a number of by-laws regulating the design of water supply and sewage disposal systems. These by-laws should be consulted before the work proceeds and, if possible, the advice of an engineer should be sought.

### 6.1 WATER SUPPLY

ref 23, 24

Water is the most precious resource in the operation of any kind of health facility and an adequate and suitable supply must be ensured before building commences. This involves assessing the demand for water, locating a suitable source and developing a system of distribution from the source of supply to the fittings.

#### Demand

ref 1

In many cases the demand will exceed the supply but wherever possible a supply of 100 litres per day per patient and member of staff is a reasonable minimum that should be aimed at. Where this amount is not available, the provision of water using fittings must be limited. In this connection it should be borne in mind that:

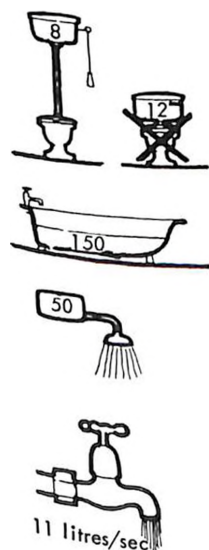

- high level w.c. cisterns require 8 litres to flush and will be used on average three to four times a day by each patient
- low level w.c. suites use more water (10-12 litres) and should not be used
- a bath takes about 150 litres each time it is used
- showers require only about 50 litres and therefore should be preferred to baths where possible
- a tap usually delivers about 11 litres of water a minute but this of course varies according to its function and the amount of control exercised over its use
- wastage of water through leaking pipes, dripping taps, etc can account for as much as 25% of the total consumption and must be guarded against.

## Water Source

The most obvious water source is usually a lake or river, but for several reasons this may not be the most satisfactory. Lakes are often polluted, if not by industrial effluent, then by animal and human waste, and bilharzia and other water-borne diseases may be present, especially nearer the shores. If lake water is to be used, it is best to draw the water from as far from the shore as possible. River water may be similarly polluted particularly if there is human settlement upstream, in fact it is safe to assume that any surface water will be contaminated and therefore require some form of treatment. In any case it must be ascertained that the supply is available all year round.

wells

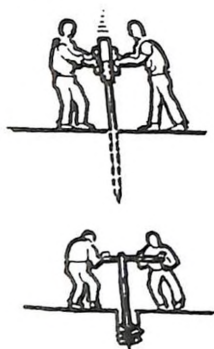

In the absence of a good surface water supply, it will be necessary to dig a well or sink a borehole. Finding water in this way is difficult particularly if no geological information is available, but shallow test holes can be made by driving in a 50 mm diameter pipe with a pointed end or alternatively a hole can be bored using an auger. If a deep-water well is needed, then more elaborate and expensive equipment is required and the services of an engineer should be sought. Boreholes made in gravel beds near large rivers will provide a better quality of water than can be found in the river itself and will often give a year round supply even if the river is seasonal. The potential output of a well or borehole can be gauged by pumping the well dry and then noting the time taken for it to refill. Again local knowledge of underground water may be extensive.

hand-dug wells

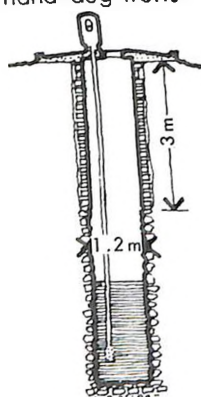

well-rings

Hand-dug wells are the most common requiring little equipment to excavate. They are usually between 6 and 10 m deep with a diameter of 900 mm or 1.2 m, the latter enabling two persons to dig at the same time. If the ground is at all unstable the well should be dug a metre at a time and then be revetted with timber to protect the diggers. The top 3 m of the well should be lined with well jointed masonry and a waterproof concrete apron sloping away from the pump should protect the top from contamination. Wells should be situated on well drained level ground above the flood level and at least 30 m from the nearest source of pollution.

A more sophisticated method of making a well is to use concrete well-rings. In this system a section of concrete pipe of about one metre diameter by 800 mm high is placed on the ground where the well is to be. A hole is dug the same size as the pipe so that the pipe sinks into the hole. This process is repeated, each time adding a further section of pipe, until the required depth is reached. This method



has the advantage of giving protection while digging and leaving a finished well which is protected from possible pollution from contaminated water in the upper strata. It is most suitable where the ground is soft and has a fairly high water content.

springs

Spring water is usually of good quality provided that the land near the seat of the spring is carefully controlled and protected from animals. It is usually free from harmful bacteria if the water has been filtered through at least 3 m of soil although it may gain some chemical impurities during this process. A stream which re-appears on the surface after a short period underground should not be mistaken for a spring.

rainwater

Rainwater in rural areas is generally pure, except perhaps for the presence of dust particles, but careful assessment must be made of the amount of water that can be collected and stored.

rainwater conservation

Assuming that all the rainwater can be collected from the roofs of the buildings of say a small hospital, it is estimated that 150 litres of water per patient will be collected for each 10 mm of rainfall. This means that in desert and semi-desert areas where water is most needed but the annual rainfall is less than 300 mm, a total amount of less than 4,500 litres per patient per year can be conserved. At the ideal minimum consumption rate of 100 litres per patient per day, this provides a supply for only 45 days. If on the other hand this amount is made to last the full year, then only 12 litres per patient would be available daily. This last figure is extremely small but nevertheless may satisfy the need for 'pure' water if alternative sources are available for bathing and washing clothes etc.

rainwater storage

In areas of moderate rainfall of say 1000 mm per annum, a full five month's supply at 100 litres per patient per day is possible or alternatively a full year's supply at 40 litres per day. In the latter case it may be impractical to provide a year round supply if, as often happens, the rainfall occurs only within certain months. For example, to maintain a water supply, even of only 40 litres per patient per day, over a dry period of four months in a 100 bed hospital would require a storage tank measuring 10 x 20 x 2.4 m high.

rainwater collection

If rainwater is to be conserved it must be considered in the design of the buildings. Large capacity gutters should be fitted to the roofs with a sufficient fall to avoid the formation of stagnant pools which form breeding ground for mosquitos. The use



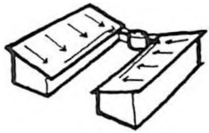

selection of source

of mono-pitch roofs will cut the cost of collection by halving the number of gutters and generally simplifying the system. Both roofs and gutters should be kept clean and it may be necessary to let the first shower run to waste after a long dry period during which dust, leaves and bird-droppings will have accumulated.

When several sources are available they should all be checked thoroughly and a selection made based upon the following criteria:

- the reliability of the source
- its purity
- the ease with which it can be supplied to the consumers.

Analysis of the suitability of water, though essential, is a job for a skilled laboratory worker and cannot be covered in this manual.

### Supply

Water can be transported from the source to the hospital storage tanks by gravity or pumping. Where a considerable distance is involved, a careful survey should be made to establish the relative levels of the source and storage tanks to establish whether gravity feed can be relied upon or alternatively the height the water is to be raised by pumping.

mechanical pumping

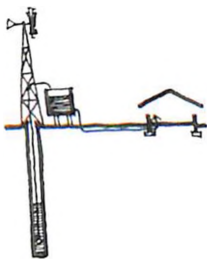

Where the money and a ready supply of power, either electrical or by petrol engine, is available then a mechanical pump is the obvious choice. A small direct drive 'displacement' pump is most suitable for shallow wells of up to 6 m deep. This type of pump has a cylinder below the water level with an operating rod extending above ground to a source of power such as a petrol engine, electric motor or windmill. If a windmill is used extra storage should be allowed for times when the wind does not blow, but on the other hand only a small capacity pump is needed because when there is wind it operates continuously. Direct suction pumps can also be used up to a depth of 6 m.

submersible pumps

For deeper boreholes of over 6 m a submersible pump, which must be powered by electricity, is required. This is a more sophisticated device costing more money and requiring expert periodic maintenance. One consolation of using electric motors is that they can be used for pumping water at times when other requirements for electrical power are minimal. If the source of supply is from a river or lake then a hydraulic ram pump may be appropriate. This type of pump works on the

principle that a large volume of water, albeit with a low head, can be used to raise a smaller volume of water through a much greater height by hydraulic pressure. The system must be designed by an engineer but, in the right circumstances, it can provide a good solution requiring no power to operate.

hand pumps

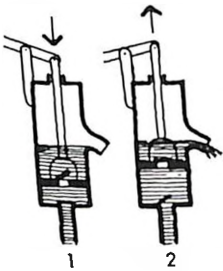

Often a hand pump will be the only feasible alternative for small units such as dispensaries, although it should be borne in mind that typically such pumps will raise about 35 litres per minute through 6 m and their effectiveness diminishes with increasing height above sea level. Manufactured hand pumps are widely available but the simpler types can also be made locally. It is wise when selecting any pump to take into account what is commonly used in the area for this will give an indication as to what type or make of pump can be maintained and for which spare parts are available.

rope and bucket lifts

Even more basic methods such as rope or bucket lifts can be employed, but even lower delivery rates of only about 15 litres per minute must then be expected. Also any type of non-piped water collection system will mean that the supply will become contaminated and therefore will require purification treatment, even if the source itself is pure.

treatment

In many rural areas the water supply will require some sort of purification before it can be used either for general purposes or for human consumption. The type of treatment required varies so greatly from place to place that general suggestions are of no value. It is therefore recommended that expert advice is obtained before deciding what procedures are necessary.

### Storage and Distribution

The capacity of water storage needed depends upon:

- the size and population of the hospital or medical unit
- the amount of water available
- the reliability of the source.

If either of the last two factors are insufficient or variable the points previously mentioned in connection with the storage of rainwater must be considered. If however there is a sufficient and reliable source, a central reservoir large enough to contain three days supply, calculated at 100 litres per person (staff and patients) per day, is required. The period of three days is based upon the need for settlement for 48 hours and a reasonable time allowance for pump maintenance. The

reservoir should have at least two separate containers to safeguard against leakage and to allow for periodic cleaning out without having to cut off the supply.

distribution

From the central reservoir water can be distributed to each department by gravity feed through small diameter pipes, 13 mm being adequate for the branches. Units such as the theatre and maternity, for which the supply of water is critical, should have their own storage tanks of about 500 litres to act as a secondary reservoir in times of shortage. A stopcock should be incorporated at the point where the main supply enters each section of the buildings so that the fittings in that part can be maintained and also so that low-priority users can be cut off from supply during times of acute shortage.

water pipes

Various piping materials are available. Galvanized steel piping with screwed connections is tough, durable and available in a wide range of diameters from 12 - 150 mm. Plastic pipes are increasingly popular due to their lightness in weight and lower cost, rigid P.V.C. is suitable for larger diameters of 50 - 150 mm whereas flexible polythene is preferable for small bore systems. Some protection is required for the latter from ultraviolet deterioration if exposed to sunlight and from sharp stones, if laid in the ground. Inside the building, plastic pipes should be positioned out of harm's way, preferably at high level with galvanized drops to fittings. It should be remembered that if polythene piping is used it requires closely spaced supports along horizontal runs to avoid sagging.

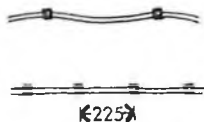

fittings

Fittings such as taps, shower roses etc, should not be economized upon. Cheap fittings will not last the life of the building and are likely to malfunction causing water-hammer (an annoying knocking in the pipes) or more seriously, a wastage of water through leakage.

### Water Heating

A comprehensive hot water system whereby hot water is supplied from a central boiler to each sink, wash basin, shower and bath can be considered a luxury for many medical buildings. This is partly due to the cost of installation but more importantly to the cost and availability of fuel. Even in areas where wood is abundant it is questionable whether, in view of the environmental problems of deforestation, it is wise to install a comprehensive wood-burning hot water system.

boilers and insulation

Where considerable amounts of hot water are required, as for example in the laundry and kitchen, a simple gravity-feed system can be fabricated locally using

almost any fuel for firing. For specific points where hot water is needed, gas-fired constant supply heaters are a reliable solution. In any case the distance between the heating process and the draw-off point should be minimized and all hot water pipes should be insulated to cut down heat loss.

solar water heaters

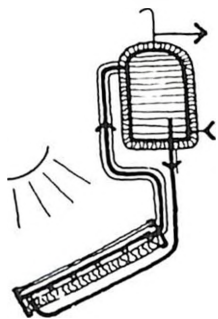

If enough capital is available, then running costs can be completely eliminated by the installation of one or several solar water heaters. Although designs have been made for local fabrication, it is more reliable to buy a unit from an experienced manufacturer. The standard sized unit will give a good quantity of hot water for most of the year in tropical countries and even in cool seasons will take the chill off the water making bathing considerably more pleasant. In Kenya a unit giving 180 litres of hot water a day costs K sh 3000/- (US \$430) and would probably pay for itself in less than two years.

## 6.2 WASTE DISPOSAL

ref 23, 25

The critical factor in determining the type of waste disposal system to be used is the availability of an ample water supply. Where there is sufficient running water then a waterborne sewerage system carrying waste matter away from sinks, sluices and water closets is to be preferred, although due to the frequent misuse of water closets and local objections to them, it may be necessary to have some pit latrines even where water is plentiful.

disposal method

page 105

If the supply of water is not unlimited then a careful estimate must be made of the number of water using fittings, particularly w.c.'s, that can be kept operational year around and the number of people using them. A pit latrine is far more satisfactory than a w.c. with no water and it should be remembered that 30 - 40 litres of water a day will be consumed by a water closet for each person using it. (In a sanitary block serving a ward this would amount to 300 - 400 litres for each w.c.). In this section both waterborne and dry methods of waste disposal will be considered.

### Septic Tanks

The most common way of dealing with waterborne sewage is by the use of septic tanks, assuming that public sewers are not available. Septic tanks are not merely storage containers for effluent, but provide the first stage of sewage treatment by



FIGURE 60  
septic tank  
section

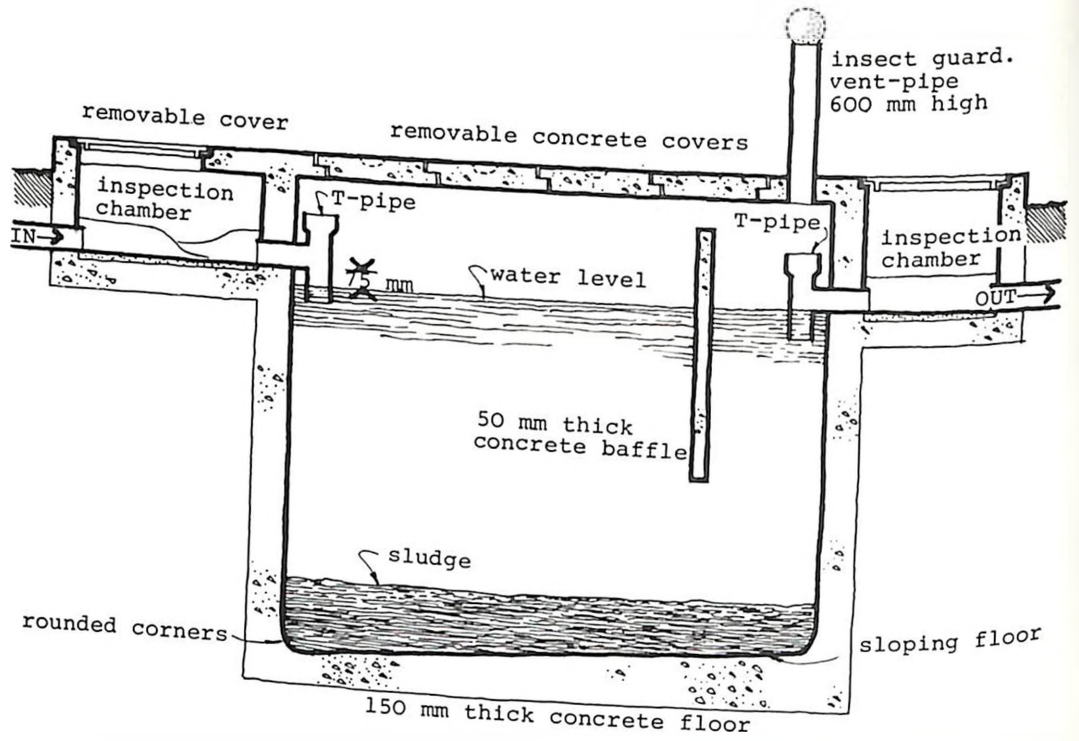

plan

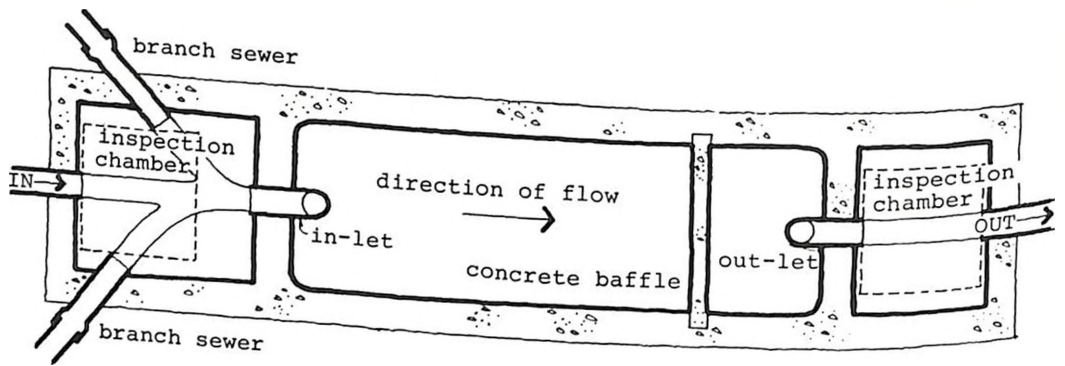

site plan

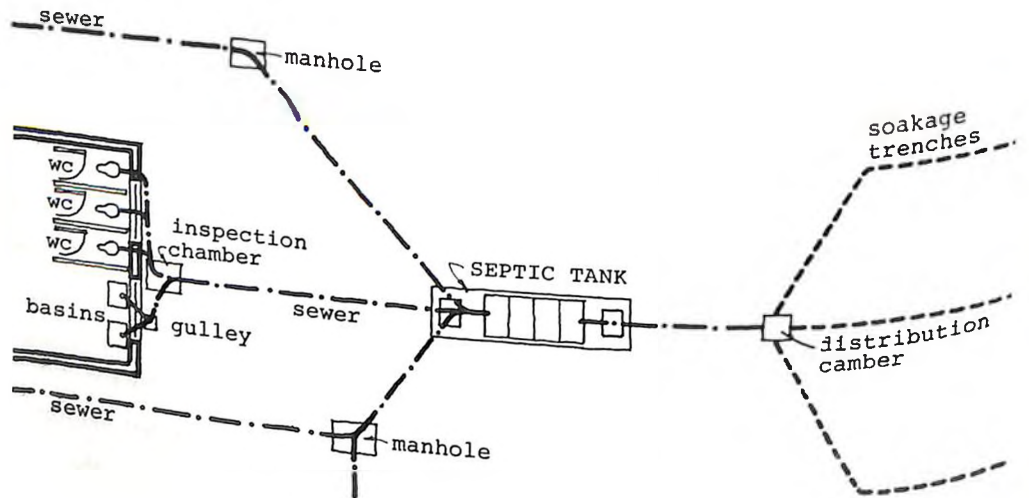



breaking down the solid matter by bacteriolytic action. It is important therefore that the addition of detergents or disinfectants, which interfere with this action, be avoided. Theoretically, septic tanks should be particularly effective in tropical climates where the warm temperatures enable the biological action to proceed at a maximum rate; this is often offset however by the failure to maintain an even flow-off of the effluent. Septic tanks should be designed to cope with all types of liquid waste, but surface water should be excluded. A typical design for a septic tank is shown in Figure 60.

septic tank capacity

ref 23

The overall capacity required can be determined from the formula  $V = P(Q+S)$  (where  $V$  is the volume,  $P$  is the number of users,  $S$  is the volume of sludge storage - 120-150 litres per person is reasonable -, and  $Q$  is the volume of water discharged per person per day). The last factor ( $Q$ ) will vary according to the availability of water using sanitary fittings, however, it will always approximate to the amount of water consumed by the hospital. As a guide, a septic tank serving say 6 w.c.s and 6 bath wastes should be 2 m long by 1 m wide by 1.6 m deep whereas one serving 20 w.c.s and 20 baths should be 3.6 m long by 1.4 m wide by 1.8 m deep.

contaminated waste

It is a common misconception that parts of the hospital discharging septic wastes such as the theatre should have a separate disposal system, but as waste from any part of the building may contain infected matter there is little point in this. It is, however, an advantage of a septic tank system that it isolates hospital waste from the domestic effluent of the surrounding community.

soakaways

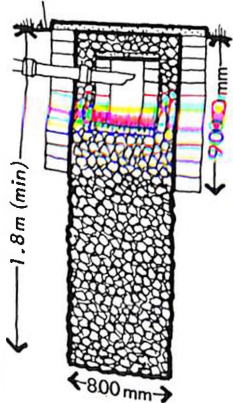

The effluent from the septic tank should be discharged into a soak-pit at least 15 m from the nearest building or distributed into disposal trenches between 600 - 800 mm deep containing ballast with sand blinding. The ground moisture thus created can and should be absorbed by growing fruit trees or vegetables to avoid the appearance of stagnant surface water. The sludge from septic tanks should be removed periodically, say every three to five years and buried or composted. As with all other sewerage installations, the design of septic tanks and soakaways should comply with the prevailing building by-laws, and wherever possible the advice of an engineer should be sought.

### Pit Latrines

The siting of pit latrines is very important and depends largely upon the soil conditions and topography of the area. In normal dry soil pollution from a pit latrine

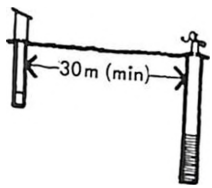

will travel only a few metres but if the water table is penetrated, then distances of 30 m are not uncommon. For this reason pits should be sited at least 30 m from the nearest well or other source of water supply. In extremely permeable ground conditions, such as gravel beds, these distances should be extended considerably and the possibility of using water-tight pits examined.

FIGURE 61  
standard pit latrine

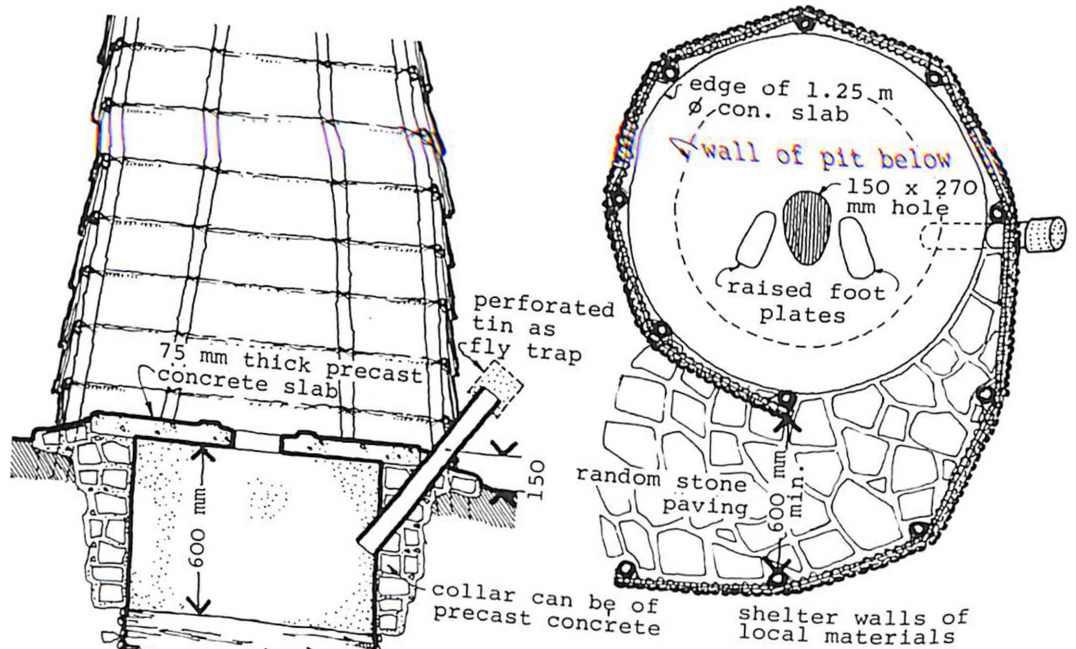
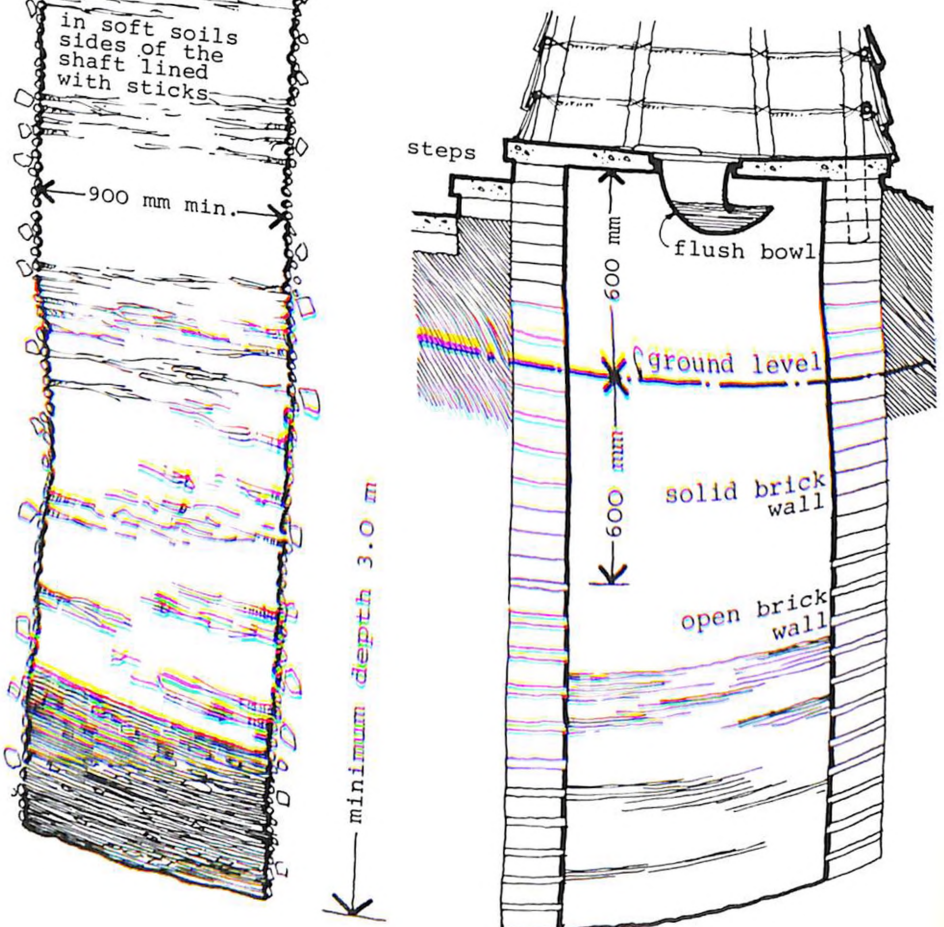

FIGURE 62 →  
pit latrine for high water table



### pit latrine size

The standard pit latrine should be a minimum of 3 m deep with a diameter of at least 900 mm to facilitate digging. The volume of the pit should be sufficient for a life of at least five years, assuming that a capacity of 50 litres per person per year is required. Figure 61 shows a typical design.

### pit latrine design

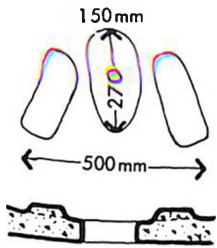

The sides of the shaft can be generally reinforced with sticks and the top 600 mm should have a concrete collar either precast or made insitu. The top of the shaft is best sealed with a circular reinforced concrete slab of 1.2 m diameter which can be precast and rolled into position. A 150 mm x 270 mm hole is needed in the centre with two raised foot plates on either side. The upper surface of the slab should be finished smooth with cement rendering and painted with two coats of a 5% solution of silicate of soda to prevent the concrete absorbing liquid sewage.

### water-seal bowl



An improvement of this basic arrangement is the addition of a shallow water-seal bowl which is flushed manually. This prevents insect breeding in the pit, cuts down the odour nuisance and requires less than 2 litres of water to flush as compared to 8 litres for a w.c. cistern. The bowl, whether of clayware, concrete or plastic, should be fixed in such a way that it can be removed for cleaning. The pit can be ventilated by a pipe protected by an insect guard.

### borehole latrine

A variation of the standard type is the borehole pit which is dug with an auger and is consequently narrower, usually 400 mm diameter, and deeper, up to 10 m. This provides an hygienic solution, but of necessity has less capacity and therefore a shorter life. Boreholes can only be made in light soils containing no large stones, in which they can be drilled very quickly.

### built-up latrine

In places where the water table is close to the surface in the wet season, the top of the latrine should be built up at least 600 mm above the ground level. The pit should be lined with an impermeable material extending from the top to 600 mm below ground level. Below that the walls can be of open construction as shown in Figure 62.



**INCEPTION:** State the aim of the project - outline the accommodation required - assess financial, material and personnel resources.

**FEASIBILITY:** Outline responsibilities - determine whether new building is needed - appoint an architect if possible - make detailed list of accommodation - prepare a provisional cost estimate - draw up a program - evaluate, select and survey the site - contact relevant authorities.

ESTABLISH THE FEASIBILITY AND PROCEED WITH THE DESIGN

**SKETCH DESIGN:** Make a diagrammatic plan of the main elements - prepare alternative designs related to the site - select suitable design and show main dimensions, allocation of space and building materials.

**DETAIL DESIGN:** Design each room and fix sizes - decide on construction method and all materials - show position of furniture and equipment - prepare and agree final design drawings - make new cost estimate - obtain outline approval of relevant authorities.

THE DESIGN SHOULD NOT BE CHANGED AFTER THIS POINT

**WORKING DRAWINGS:** Make accurate drawings giving all information needed to construct the works - select all fittings, fixtures and equipment - obtain quotes for special items - obtain building regulations approval.

**BILL OF QUANTITIES:** List all materials and items to be used and their quantities - make final cost estimate - order long-delivery materials - initiate site clearance.

**TENDERING:** Make short list of contractors - issue working drawings, bill of quantities and contract conditions to selected contractors - scrutinize tenders and select the best - make any changes required for cost reasons - sign the contract - nominate subcontractors.

CHANGES BEYOND THIS STAGE WILL COST EXTRA TIME AND MONEY

**SITE WORK:** Agree contractors program - supervise work on site - hold 2-weekly progress meetings with contractor - make interim payments.

**PRACTICAL COMPLETION:** Inspect the work and make list of defects - hold hand-over meeting and accept keys from the contractor.

**FINAL COMPLETION:** Inspect the works and check that the defects are made good - settle final account by releasing the retention sum.

CHAPTER SEVEN →

## CHAPTER SEVEN - CONTRACT PLANNING

introduction

Once all the decisions have been made concerning the layout and design of the new buildings and the materials and method of their construction, the procedures necessary for the actual building work can be started. This process includes broadly:

- the preparation of drawings and other information for the builder to use
- the selection of a suitable contractor
- the supervision of the work on site
- the final commissioning and occupation of the building.

The successful completion of each of these stages will make or break the project and should therefore be watched over most carefully. It is assumed throughout this chapter that a local contractor will undertake the building work but the same procedures are just as important if direct labour is to be used.

### 7.1 CONTRACT DOCUMENTS

introduction

The purpose of the contract documents is threefold in that firstly they provide a basis upon which a contractor can give a price for the work to be done; secondly they describe the works which the contractor undertakes to complete when he signs the contract; and thirdly they provide all the information which the contractor actually needs to construct the buildings. The contract documents usually consist of working drawings, a specification or bill of quantities and the contract itself.

#### Working Drawings

Working drawings consist of plans, sections, elevations and details of the site and buildings. They provide all the technical information necessary for the contractor to construct the building. They are technical drawings usually made by an architect or draughtsman but this should not deter others from making their own drawings. Figures 63-65 show the basic drawings required as drawn by an architect using proper drawing instruments, but equally useful drawings can be made either freehand or with a ruler on squared paper. Drawings should be to a scale such as 1:50 where 10 mm on the drawing represents 500 mm in reality, and show all the component parts of the building, noting the material from which they are made,



FIGURE 63  
working drawing plan

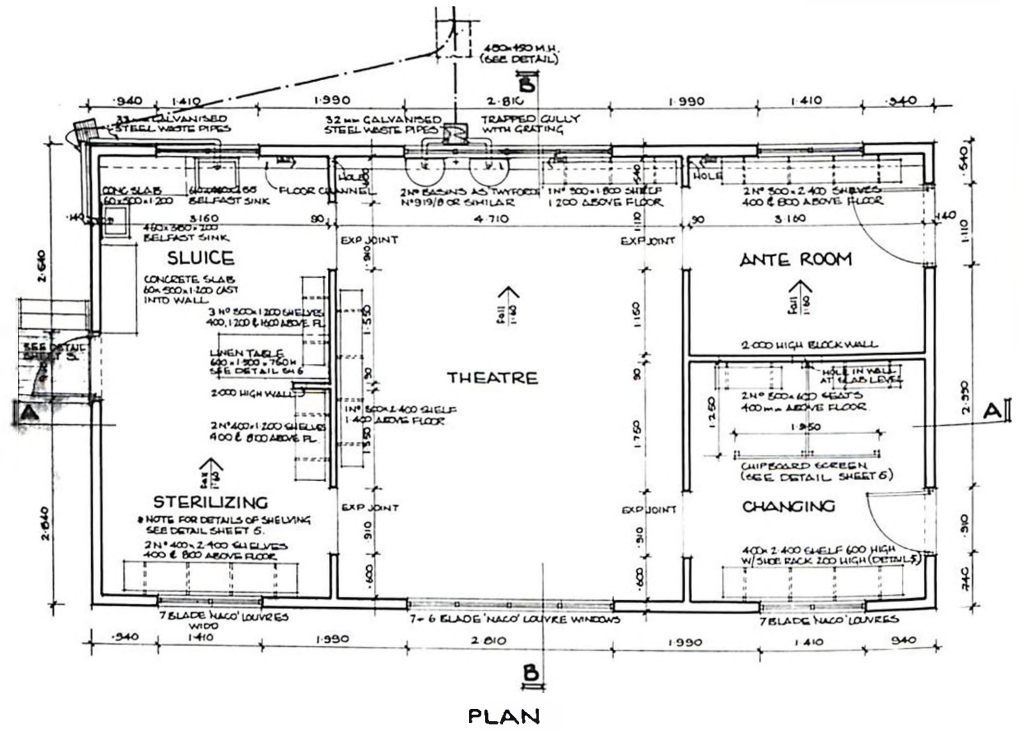

FIGURE 64  
working drawing section

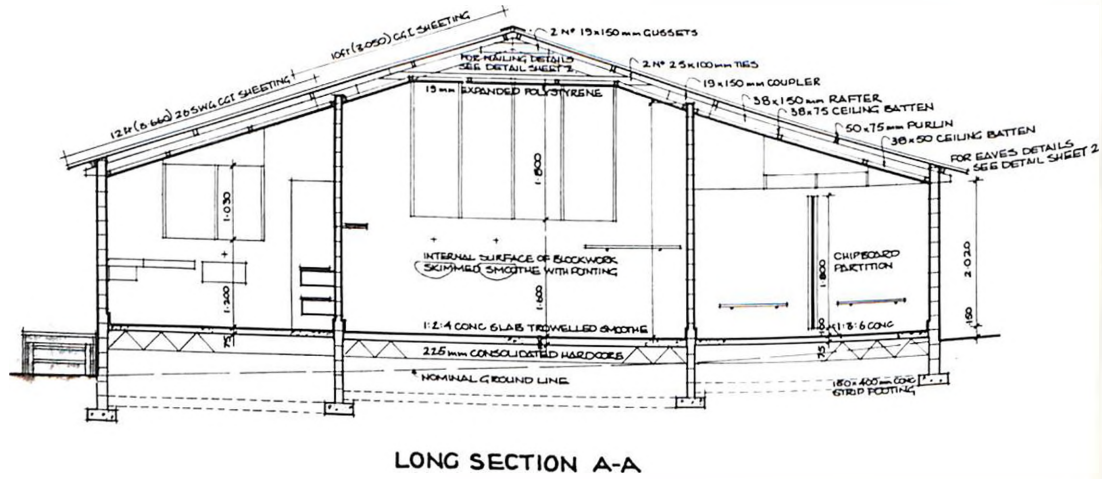
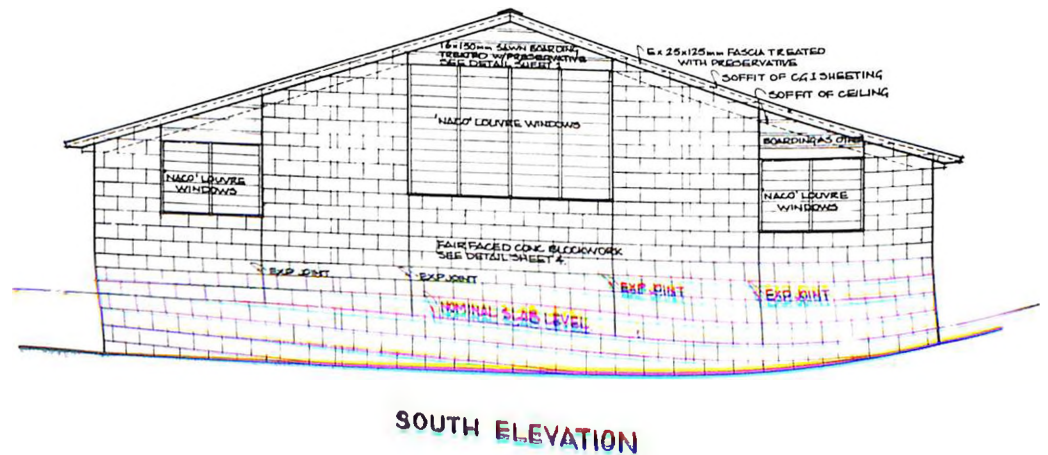

FIGURE 65  
working drawing elevation



their size and their position. Generally these will include:

- main elements such as: foundations, floors, walls and roof including the openings to be left for doors and windows
- secondary elements such as: doors, windows, partitions and ceilings
- fixtures and fittings such as: sinks, baths and w.c.s, shelves, cupboards and benches
- finishes such as: plastering, floor covering and painting
- service runs such as: sewers, water pipes and electrical wiring.

## details

Besides the main drawings which show the overall layout of the building, a further set of detail drawings will be needed to show how the building is constructed. These will cover such items as the roof construction and fitted furniture and also doors and windows that may be made off the site. As with the main drawings, the details can be drawn freehand on squared paper as in Figure 66.

FIGURE 66  
free hand detail

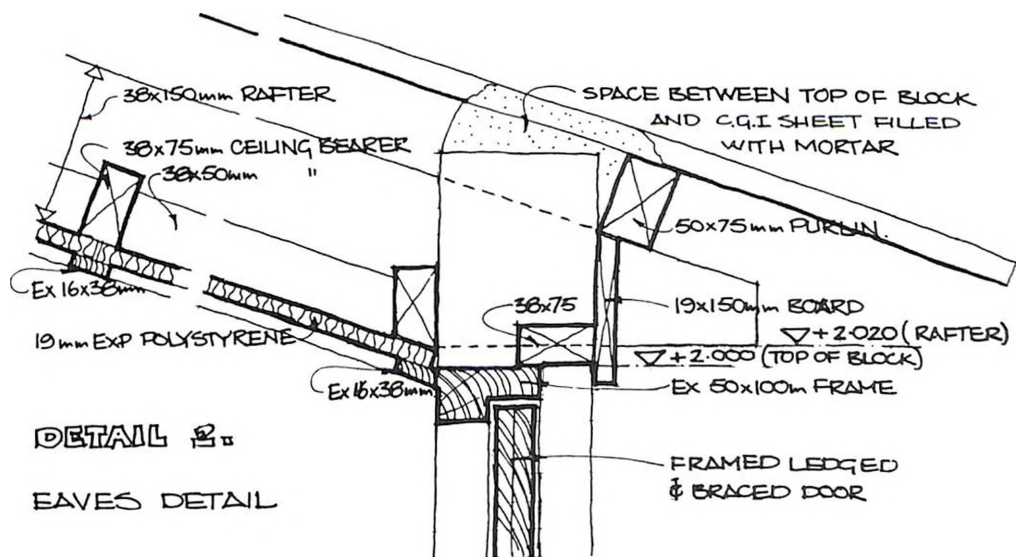

## site plan

The only other drawing required is a site plan showing the exact position of the new building in relation to other buildings or landmarks on the site. This can be drawn to a small scale, say, 1:200 and should show any external works related to the construction, and all service connections to the building.

The working drawings should only be started after the design has been finalized and must be completed before a contractor can give an accurate price for the work and before the contract can be signed. Changes in the drawings after this stage are likely to cause additional expense.

FIGURE 67  
bill of quantities sample  
page

Item No.		Unit	Quant.	Rate	SAs.	ctr.
	<u>E. ROOF</u>					
	<u>(1). Timber support structure</u>					
	Provide, assemble, erect and fix the following in select quality <u>Cypress soft wood pressure impregnated</u> (Colcure or similar approved timber preservative); in <u>sawn (unplaned)</u> members					
	UNIT OF MEASUREMENT l.m. = linear metre sq.m. = square metre c.m. = cubic metre					
E. 1	38x150 mm. (1 1/2"x6") rafters;	l.m.	25.00			
E. 2	19x150 mm. (3/4"x6") coupling pieces to joints in rafters nailed to same as shown in detail on drawings;	l.m.	4.80			
E. 3	ditto to joints at ridge;	l.m.	4.00			
E. 4	25x100 mm. (1"x4") ties (main ceiling bearers) nailed to rafters as shown in detail;	l.m.	14.80			
					quantity in metres or number of items	
E. 5	25x150 mm. (1"x6") rafters along gable walls;	l.m.	25.00			
E. 6	19x150 mm. (3/4"x6") coupling pieces to joints in above as item E. 2;	l.m.	2.40			
E. 7	ditto to joints at ridge;	l.m.	2.00			
E. 8	25x100 mm. (1"x4") ties (ceiling bearer) as item E. 4;	l.m.	7.40			cost per unit
E. 9	50x75 mm. (2"x3") purlins nailed to rafters;	l.m.	73.30			
E. 10	25x75 mm. (1"x3") coupling pieces to joints in purlins nailed to both faces as shown in detail;	l.m.	12.00			
					total cost of item	
	in <u>planed</u> members:					
E. 11	25x125 mm. (1"x5") barge board nailed to purlin ends	l.m.	26.00			
E. 12	Provide and paint three coats Sadolin's Pinotex wood preservative in approved colour to barge board	sq.m.	7.15			
	CARRY FORWARD					
	summary of cost for this page					

Bill of Quantities

A bill of quantities is a document which lists all the materials and work to be undertaken giving an amount for each item, a sample is shown of a typical page in Figure 67. It is most useful in that an estimate of the cost can be quickly made



by simply adding the unit cost for each item and computing the total costs which added together give an overall price. It also helps the contractor with his pricing and ensures that the price he gives for the contract covers all the work. The proper pricing of a 'bill' by the builder will not only ensure an accurate and realistic price, but will result in a lower bid than would be made by using a more casual method of estimating. Also the 'bill' makes the ordering of materials either by the owner or the builder a simple task.

making a 'bill'

Ideally a bill of quantities should be drawn up by a quantity surveyor, but as in most cases one will not be available, it ought to be possible for a doctor or administrator to make a useful bill for a simple building listing all the major materials such as cement, timber and roofing material with a quantity for each. This will be essential if the employer, in order to keep control of capital expenditure, buys all the materials himself, hiring the contractor on a labour-only basis. In any case it will pay dividends in both cost savings and in the smooth running of the contract.

page 126

specification

If a proper bill cannot be made a specification will suffice to supplement the information shown on the drawings. It is similar to a bill giving a precise description of all the materials and items to be used in the contract. The main disadvantage is that the quantities are not included which means that the contractor must measure the amounts needed from the drawings in order to make his estimate. Consequently estimates from say, three contractors will not necessarily be comparable.

### The Contract

The contract is the legal document which binds the employer or building owner and the contractor or builder to an agreement in which the contractor undertakes to construct the buildings according to the drawings and bills of quantity within a given length of time, and the employer undertakes to pay the contractor an agreed sum of money upon satisfactory completion of the work. If an architect is employed, he is the third party to the contract and although he is usually retained by the employer, he stands as arbiter in the case of contractual disputes.

contingencies

It is clear that the contractor only agrees to build the works as described in the drawings and bills which accompany the contract and therefore can claim extra money for any necessary work originally left out. For this reason it is imperative that the drawings be checked carefully and that a contingency sum of at least

10% be allowed for the inevitable omissions. This amount should be kept separate from the contract otherwise the contractor will tend to use it up as a matter of course. Most contingencies arise in the initial stages when the foundations are being made for it is then that unforeseen problems such as pockets of poor soil are most likely to come to light. It is therefore not unreasonable if a larger percentage of the contingency sum is used up in the earlier stages of the contract. For example the cost of the foundations should only be about 10-15% of the total contract sum, but 20-30% of the contingency sum may be used up during this stage of the work.

contract clauses

Besides the basic agreement involved, a good building contract should also include further conditions to ensure the smooth running of the building phase. The following areas at least should be covered.

start and completion dates

The contract should specify when the contractor can take possession of the site and on what date the works will be finished.

damages for delay

If the contractor takes longer for the work than is agreed for reasons not approved by the architect, (see below) then he should be required to pay damages to the employer. The amount should not constitute a penalty but should rather be determined on the legitimate loss to the employer caused by the delay in occupying the building. This is normally assessed in terms of loss of rent or business but in the case of a hospital, a fair amount would be 10% of the value of the uncompleted work divided by 52 to give a weekly rate.

incentives

If time is particularly important, it is in order to offer the contractor an incentive bonus scheme whereby he is paid an amount for each week that his actual finishing date precedes the agreed **completion** date, but any such scheme should be arranged outside the contract.

extension of time

In some *circumstances* the **contractor** may have a justifiable reason for delay in the completion of the contract. The proper criterion for determining what is justifiable is whether the contractor could possibly foresee the cause for the delay at the time of signing the contract. An example would be if the contract was signed just before the start of the rainy season, the contractor cannot claim that he has been held up by the rains which he should have allowed for in his programming; if on the other hand there is unexpectedly heavy rain for several days at a normally dry time of year, then the contract could reasonably be extended by the same number of days.



granting of extensions	The same reasoning can be applied to other common causes for extension requests, such as difficulty in obtaining materials or shortage of labour. Examined in this way, it is found that very few requests for extension can be justified. On the other hand the contractor's difficulties, particularly in obtaining materials and skilled labour in remote areas, deserve some sympathy and understanding in considering claims for extension. It is wise to ask the contractor if he has taken these things into account when he first commits himself to a completion date.
building regulations	The contractor should be responsible for complying with any rules, regulations or by-laws passed by local or central government relating to building, although approval of the drawings should have already been gained by the employer. He should inform all interested bodies, including utility companies and pay any necessary fees for such things as stopping off existing water or electricity mains.
variations	Inevitably there will be some variation from the way the works were originally described either because of an omission in the original drawings or because some new item is to be added. In this case the contractor should provide a separate estimate for the work and materials involved and if the estimate is acceptable he should be instructed to go ahead and the payment duly made. On no account should the contractor proceed with any variation without permission of the architect or the employer.
insurance	The contractor should be required to take out an insurance policy against injuries arising out of the work on site otherwise the employer may become liable.
defects	It should be specified that the contractor make good any defects such as cracks, and mistakes such as the wrong placement of doors or windows which arise from faulty workmanship. This obligation should extend at least three, and preferably six months, beyond the end of the contract when shrinkage cracks for example will still be appearing. Ideally, the defects liability period should be long enough to encompass the normal range of weather conditions especially the rainy season when faults in the roof for example may first become apparent.
provisional and prime cost sums	Certain lump sum items may be included in the contract. Provisional sums are amounts to cover items which cannot be described, and therefore costed, at the time of tendering such as restorative work to the site made necessary by the new works. Prime cost sums (P.C. sums) can cover items such as equipment and furniture for which a separate price, from a supplier, has been obtained before tendering making it unnecessary for the contractor to estimate those items.

payment

The method of payment of the agreed contract sum is most critical to the control of the work by the architect or employer. The best procedure is to make payments in instalments either monthly, in which case the work done during the past month must be valued (this is really only possible for larger jobs where a quantity surveyor is employed) or else at definable stages in the work such as slab level, wall plate level, completion of roof etc. The latter method is preferred for small developments in that the amounts due at each stage are easier to assess.

cost breakdown

To help in estimating the amount due at each stage it is best to ask the contractor to break down his total price giving a price for each part of the work, either at the time of tendering or before the job begins. Although it is difficult to generalize, the following breakdown for a typical low cost building can be used as a guide:

- foundations	13%
- floor	6%
- external walls	14%
- internal walls	13%
- windows and doors	10%
- roof	20%
- sanitary installation	18%
- electrical installation	6%

time of payment

Whichever method is chosen, it is absolutely vital that payments are not made until the corresponding work has been completed and inspected thoroughly, preferably by an architect. Once the money has been paid it is extremely difficult to persuade a contractor to rectify poor or inaccurate work. On the other hand once the work has been completed satisfactorily, the contractor should be paid promptly so that he can pay his workmen and buy further materials for he will usually be short of capital. Even so payments should be made for only 90% of the value of the work completed, 10% being retained until three or six months after completion by which time all defects should have been rectified.

arbitration

Finally it should be agreed in advance and laid down in the contract that any dispute arising out of the work which cannot be settled between the parties themselves should be referred to an independently selected arbiter, preferably an architect, surveyor or other person familiar with building matters, whose decision

will be final. There are several advantages of arbitration over normal legal proceedings for the settlement of building disputes. Firstly it is quicker, an important factor when work on site maybe at a standstill; secondly it costs a good deal less because lawyers are not normally retained; and thirdly the arbiter will be an 'expert' as opposed to a judge who may be quite ignorant of building technicalities. An arbiter can usually be appointed by the head of the architectural professional body.

Considerable space has been devoted to the contract, reflecting its importance in the building process. It is all too easy to enter into a loose and friendly agreement at the start when no clouds mar the horizon only to find there is no legal recourse when problems arise. If some of the suggested contract clauses seem harsh on the contractor this is not to imply intolerance of his problems but rather that it is easier to be tolerant over specific troubles that arise if generally one is operating within a sound legal framework. It should be borne in mind that the contractor himself will often be inexperienced in the administrative aspects of his work and may appreciate guidance and co-operation in many areas.

standard forms

Most standard forms of contract are designed for large scale projects and are inappropriate for small works in rural areas. It is therefore recommended that a short form, such as the one shown in Appendix Four, which is specially adapted for small works, should be used.

page 139

## 7.2 TENDERING

competitive tendering

There are two generally accepted methods of selecting a building contractor. The first and by far the most common is by competitive tender. In this method a number of contractors (minimum three, maximum six) are selected and each asked to prepare an estimate based upon the working drawings, bill of quantities, if available and the contract conditions. Then generally the contractor who submits the lowest estimate or tender is selected to do the work, providing that he has priced for the complete job. If there is a sufficiently wide choice, only those contractors whose work is known to be good and who are capable of preparing a proper estimate should be asked to tender. The tenderers should not know who their competitors are and a fairly short period (two-three weeks) should be allowed for estimates to be prepared. The tenders should be submitted in sealed envelopes by a specified time and opened at the same time in the presence of an independent witness.

checking the estimate

Before the contract is signed with the lowest tenderer, his estimate should be scrutinized to ascertain that he has considered all the work in his price and is satisfied with the amount of time allowed for the job. It is difficult to check the contractor's prices without prior experience of local costs, but it might be useful to compare his cost breakdown with the one given earlier in this section to see if any items are disproportionately highly priced. If a bill of quantities is used, the contractor's figures should be checked against the quantity surveyor's estimate.

page 124

fluctuating contract

The tender should also include a list of rates for both labour and materials used in the estimate so that future variations can be priced properly and, more important, so that future claims for the increased cost of labour and materials can be properly assessed. This last point is particularly important if a fluctuating price is asked for whereby the contractor makes his estimate at current prices and then is allowed extra money for increased costs beyond his control. It is recommended here, however, that only fixed price tenders should be obtained.

contract signing

Finally, before the contract is signed it should be absolutely clear that the contractor understands and accepts all the clauses of the contract. A contract is only valid if the parties to it fully understand its meaning.

negotiated contract

An alternative to competitive tendering is to enter into a negotiated contract. This is applicable where there is only one contractor available or where a particular contractor is well known and trusted by the employer, possibly through past work, and is therefore preferred for the job. In this method the contractor prepares his estimate in co-operation with the employer and architect. The advantage of this system is that the contractor can be brought in at an earlier stage and his local experience drawn upon for decisions about types of construction and materials which could involve cost savings, and also so that materials which have long delivery times can be ordered in advance of the start on site. The disadvantage is that the safeguards inherent in the competitive system do not apply making it more difficult to be certain that the negotiated price is as low as it should be. This system should therefore be avoided if possible, especially if the services of an architect or quantity surveyor are not available.

direct labour

A further alternative is to use the so called 'direct labour' method of building in which the employer buys all the building materials from an ordering list (a bill of quantities is not necessary) and then hires labour directly. This method involves the employer in more organizational work because he is in effect acting as his own

contractor but for small jobs it has been found to be the most foolproof way of getting a building built especially in areas where there is no experienced or reliable contractor. By eliminating the contractor's profit and allowing tight control over the use of materials, the direct labour method should provide the cheapest solution. It also enables the progress of the work to be controlled by the employer rather than the contractor which generally leads to a shorter building period.

### 7.3 APPROVALS

Before the drawings can be sent out to tender or a contract can be signed, all necessary permissions must be obtained from the authorities. In rural areas this will be a matter of contacting the local council within whose jurisdiction the site falls, who will certify compliance with the building regulations. The procedure is usually that a preliminary submission of the drawings together with a completed application form is made to the council. The building inspector or his representative will then give his comments possibly with recommendations for changes. The drawings should then be revised accordingly and resubmitted for official approval. For hospital buildings, the approval of the Ministry of Health should be sought and the Ministry of Works ought to be consulted, particularly if they are to be responsible for the maintenance of the buildings at sometime in the future.

All of the above authorities should be consulted from the earliest stages of the project so that their final approval of the scheme becomes merely a formality.

### 7.4 SITE SUPERVISION

Supervision of the work on site should be carried out daily, making it unlikely that a person well qualified in building matters will be available for the task. Nevertheless, this activity is absolutely vital to the success of the project and must be undertaken conscientiously.

purpose of supervision

The point of supervision of the contractor's work is simply to ensure that the buildings are constructed according to the working drawings. It only becomes a problem when there is some doubt about the contractor's ability or motivation and when the architect or his agent is only able to visit the site infrequently. In these circumstances the site must be visited daily by some interested representative of the



employer. The person with most interest in building matters should be selected for this job and he should take the time to go through the drawings carefully with the architect noting particular points where problems may arise. Although such a site representative will probably be a layman in building terms, his interest in the work will in itself have a beneficial effect.

clerk of works

Of course where an architect is retained to provide a full service, then he will be responsible for supervision and will probably appoint a clerk of works to remain permanently on site or at least through the critical stages of the contract. There are many areas where the work on site can go wrong and it is only by a thorough understanding of the drawings and careful supervision that errors can be avoided. However, there are a number of things particularly to look out for.

foundations

Make sure that the trenches are dug to a depth at which the ground is solid and undisturbed and the bottom is flat and the sides are vertical. Topsoil which usually contains organic matter should be removed over the area of the building to a minimum depth of 150 mm and any pockets of poor or loose soil below that excavated and filled with well compacted hard core.

concrete floors

Care should be taken that the hard core under the slab is well hammered down and any remaining cavities filled in with finely crushed stone or sand to avoid cracking of the slab due to uneven support. Check the ingredients of the concrete before mixing. Unspoiled cement should be smooth like flour; granulated or caked cement (spoiled by water) should be rejected. Sand should be fine and clean and contain no organic material; sea sand must be washed to remove the salt, which is harmful to cement. Gravel aggregate must also be clean as well as hard and not too smooth of surface. Check also that the proportions of the mix given on the drawings (always given in the order, cement-sand-aggregate) are followed by the contractor, and that they are well mixed with not too much water, say five times as much water as cement.

concrete placing

Make a point of being on site when the slab is cast so you can check that: the ground surface has been wetted, the correct thickness is being poured, provision for any necessary expansion joints is made, that the work is done swiftly without breaks (all concrete should be in place within an hour of water being added) and that after trowelling smooth the work is covered with damp sacks or straw for at least three days. The reason for wetting the ground beforehand and keeping moist after casting is in order to avoid water being lost from the mix too rapidly. The

setting of cement is a chemical process requiring the presence of water and not, as is sometimes thought, simply a matter of the mix drying out until it is hard.

#### masonry walls

First inspect the blocks, bricks or stones to be used, particularly that their thickness dimensions are within a tolerance of 5 mm. Badly chipped blocks and twisted overburned bricks should be rejected. If concrete blocks have insufficient cement they will be brittle. A simple test is to drop the block onto a hard surface from shoulder height, if it breaks into pieces then the quality is poor. The mortar used should be checked as to the quality of cement or lime and the sand, making sure there is a minimum of large particles. It is not good practice to soak concrete blocks before laying as this will result in shrinkage cracks after drying out. On the other hand, wetting the faces which come into contact with the mortar will prevent too much water being lost from the mortar into the dry blocks thus improving the mortar set.

#### masonry laying

In the masonry laying, check that the walls are plumb and true and of even thickness. If a plaster finish is planned then the rougher the surface, chips in blocks, lumps of mortar etc, the better. If the wall is to be unplastered then good quality block laying must be done. It is always a good idea to ask the mason to make a one square metre panel of blockwork which, if satisfactory, can be used as a yardstick against which to judge subsequent work. At this stage it may be as well to check with a tape measure that the sizes of rooms and the positions of door and window openings are in accordance with the drawings.

#### roof

The roofing timbers should be straight and long enough to avoid joints in the main members. If preservative is to be applied on site, make sure that the wood is totally immersed after all cutting has been done. The rafters should be securely fixed to the wall by galvanized metal straps extending down at least four courses below the wall plate to prevent the roof blowing off at some future date. The roofing sheets should arrive on site undamaged and be of the right gauge which should be marked on each sheet. The roof must be completed before internal finishes, joinery or fittings can be started.

#### fittings and fixtures

Many items such as doors, windows, cabinetwork, etc, will be made off the site, often by a sub-contractor. If the main contractor asks approval for this, ask him to produce a sample of the work and if it is satisfactory, keep it and then give approval on the condition that the items made for the building will be to the same standard. Check that fittings, especially sanitary appliances, are fixed at the

correct height and also that doors and windows open the right way according to the drawings.

care of materials

It is the contractor's responsibility to take proper care and ensure the security of materials on the site. It is particularly important to protect cement from dampness and sunlight and to ensure that timber is stacked off the ground. Valuable items such as windows, ironmongery and sanitary fittings should be kept in a lockable store. It is also a good idea to check with the contractor at regular intervals whether he has sufficient materials on-site to avoid future delays. If in doubt about any material or procedure on site, never hesitate to ask the contractor or his foreman and, if a satisfactory reply is not forthcoming, seek advice elsewhere.

## 7.5 COMPLETION AND HANDOVER

There are two stages in the completion procedure for a building. The first is the date when the building is ready for occupation which should coincide with the date for completion given in the contract. The second is the final completion which takes place at the end of the defects liability period, 3-6 months after the practical completion according to the contract conditions, by which time all the defects in the work should be rectified and the final account settled by release of the 10% retention sum.

building inspection

A thorough inspection of all the work should be made at each stage. Before occupation the employer ought to be satisfied that the works are substantially complete in accordance with the terms of the contract. Each room should be examined and items checked off (a sample checklist is given in Appendix Five) as either satisfactory or requiring further attention. In this way a list of defects can be made which the contractor must put in order before the final completion date. It is tempting at this stage, when the long ordeal of the building period is over and there is pressure to occupy the building, to ignore what may seem to be trivial matters such as paint on the windows, badly fixed door handles, etc, but the contractor has allowed for putting these things right in his tender and should be required to do it.

page 142

installation checking

Particular attention should be given to the installations in the building. The water supply and drainage must be tested and the electricity outlets and switches tried. In this case it is advisable to enlist the help of someone with technical knowledge

and certainly the person who will be responsible for future maintenance. Finally before the building can be occupied, the approval of the local authority and possibly the Ministry of Works (where they will be responsible for maintenance) must be sought.

final inspection

The final completion should be simply a matter of making sure that all the defects noted at practical completion are made good and that any further defects such as shrinkage, cracks, and drainage problems which have arisen in the meantime are dealt with. The contractor should be given reasonable access to the building during this time and although he is not responsible for incidental damage during this period, caused for example by the moving in of furniture, it is wise to ask him to do repairs on a fee basis.

completion

After the final inspection is completed satisfactorily, the certificate of completion can be signed and the contractor receives the 10% retention sum. This effectively completes the contract procedure and it only remains for the employer to ensure that he has the necessary information in the way of drawings and technical literature to enable him to take care of the building in the future.

## APPENDIX ONE - ARCHITECT'S FEES

Architect's fee scales vary from country to country; the information given in this appendix is therefore intended only to provide a guideline as to how much money should be set aside for fees in the provisional cost estimate. If an architect is to be retained, a full scale of fees and a set of conditions of engagement should be obtained from the architect himself or from the national regulating body for architects.

method of calculation

Architectural fees are usually worked out on a percentage of the total contract value, the actual percentage varying according to the value of the contract and the extent of the services provided. If an architect is hired to design the scheme, produce all the drawings and supervise the work on site then a full fee is charged. For a small job of say, less than K sh 40,000, the fee would be 10% of the contract value, this figure decreasing incrementally to 6% for larger contracts of over say, K sh 320,000 in value.

partial service

In remote areas it may be impractical for an architect to provide a full service, but he may nevertheless be retained to prepare a design or a design and working drawings. For this partial service a proportion only of the full fee is charged. In order to assess this, the work is divided into five stages which themselves relate to the programme stages set out at the beginning of each chapter. They are:

- a - inception - preliminary discussion with the client and formulation of a brief
- b - preliminary design - the preparation of sketch design proposals
- c - final design
- d - working drawings
- e - tendering and site supervision.

The proportion of the full fee due can be worked out according to the following percentages:

Stages a and b	=	16.5%	of the full fee
Up to and including stage c	=	33%	" " " "
Up to and including stage d	=	75%	" " " "
Up to and including stage e	=	100%	" " " "



work to existing buildings

For the conversion or improvement of existing buildings, the amount of architectural work is considerable whereas the corresponding contract value tends to be low. This is reflected in the higher fee percentage usually charged for this kind of work. For example, a small conversion job of under K sh 160,000 would carry a fee of 12.5% and a large job of over K sh 320,000 would be charged at 10%.

fees and building cost

The percentage system for fee assessment by its nature makes the undertaking of lower cost projects by an architect unattractive. The architectural work involved in the design and construction of low cost buildings is as great if not greater than for medium or expensively priced buildings, but the fee is considerably less, often not even enough to cover the architect's costs.

time charging

This can be overcome by hiring an architect on a time basis to undertake a specific task such as drawing up a site plan. If this is done he will charge at a rate of around 0.15% of his annual salary per hour which means that his time should be utilized to the fullest.

## APPENDIX TWO - SURVEYING NOTES

The aim of a survey is to determine the dimensions of the site, its physical characteristics and the nature and position of natural and man-made features. In practice the main task is to locate and dimension the boundaries and establish and quantify changes in level.

plan dimensions

For a site with straight boundaries the fixing of the main features in the horizontal plane is a simple matter. The main steps as shown in Figure 68 are:

- measure the length of each side of the site
- measure the diagonals
- select one side (usually the longest) as a base line
- beginning at one end, measure the distance of important features from the base line and their position along it
- on a large site each boundary line can be used as a base line or new base lines can be set up within the site parallel to one of the boundaries
- dimensions from the base line to the object must be taken at right angles to the base line (check by making a 3, 4, 5 triangle).

FIGURE 68  
surveying a regular site

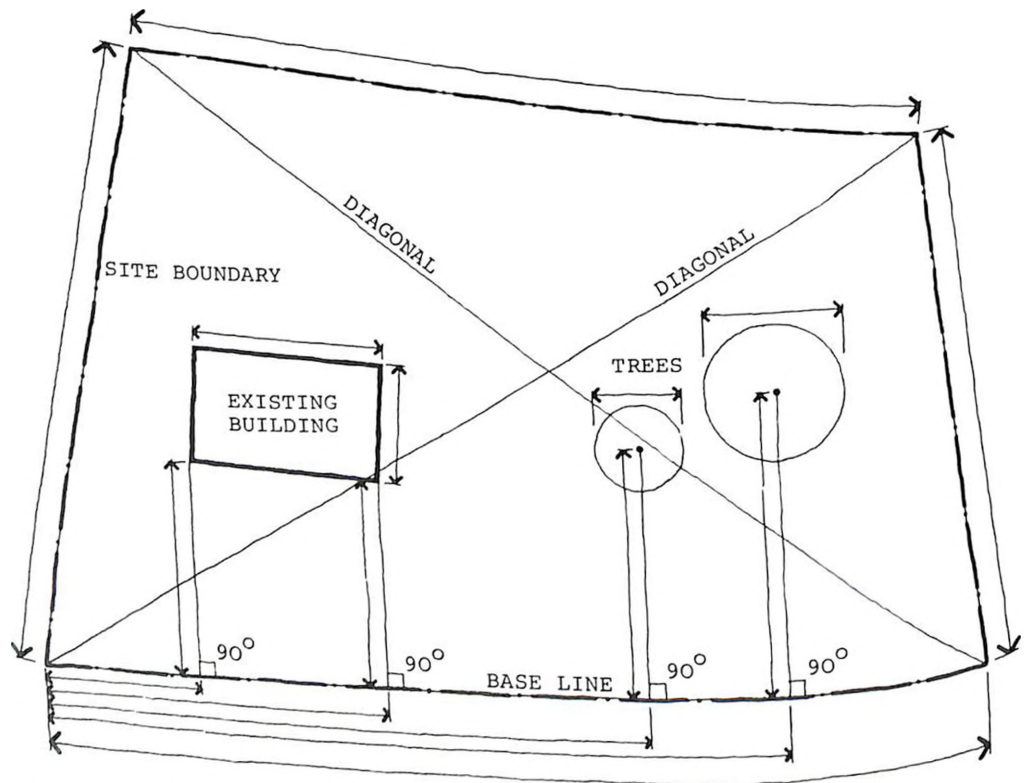

For sites with more complicated boundary conditions the same principles are followed except that four base lines, making the largest rectangle possible within the boundaries of the site, should be set out as shown in Figure 69. The base lines can be related to features on the site or simply strings tied between pegs stuck into the ground. The boundaries are plotted by taking right-angular dimensions at regular intervals along the base lines. Important features are positioned relative to the base lines and again additional base lines may be necessary for larger sites.

FIGURE 69  
surveying an irregular site

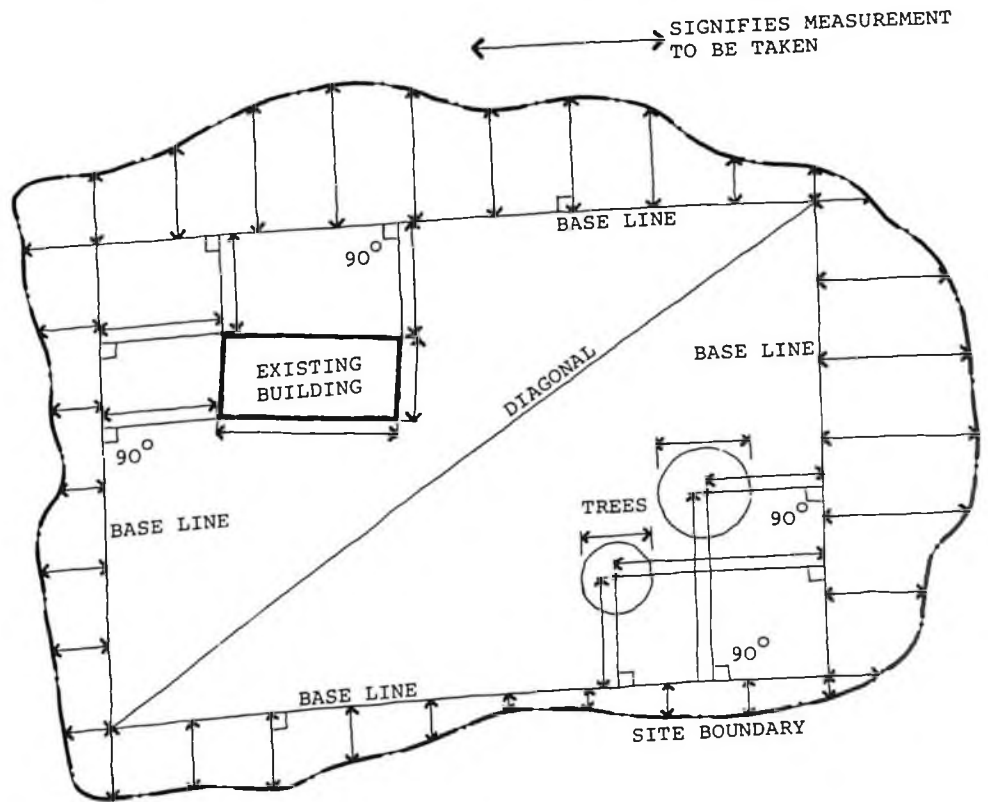

levels

The fixing of vertical dimensions or 'levels' is a more complex matter especially on a hilly site. The best procedure is to divide the site up into a grid related to the base line, the size of the grid depends upon the irregularity of the levels but a 6 m grid would be typical. One point on the grid is then chosen as the datum and the levels of the other points on the grid related to it. To do this a levelling device of some kind must be used. If a proper surveyor's level is not available, a builder's spirit level or, simpler still, a pendulum level can be used as shown in Figure 70.

levelling

The main steps as shown in Figure 71 are:

- set up the level at position 1
- a second person holds a rod vertically at position 2

- view the rod along the level marking the height observed
- measure the height from the mark to the ground (x)
- note the height of the level (y) which is a constant
- subtract x from y to give the level of position 2 relative to position 1, (if 2 is lower the height will be a minus quantity)
- repeat this procedure for all positions on the grid visible from position 1
- for distant points or ones obscured by the terrain, move the level to a suitable point whose level has already been established.

Once all the levels have been worked out they can be brought into positive figures by adding a number greater than the largest minus quantity to each of them. Additional levels can be taken where it is anticipated that new buildings will be sited or where there are particularly sharp changes in level.

FIGURE 70  
pendulum level

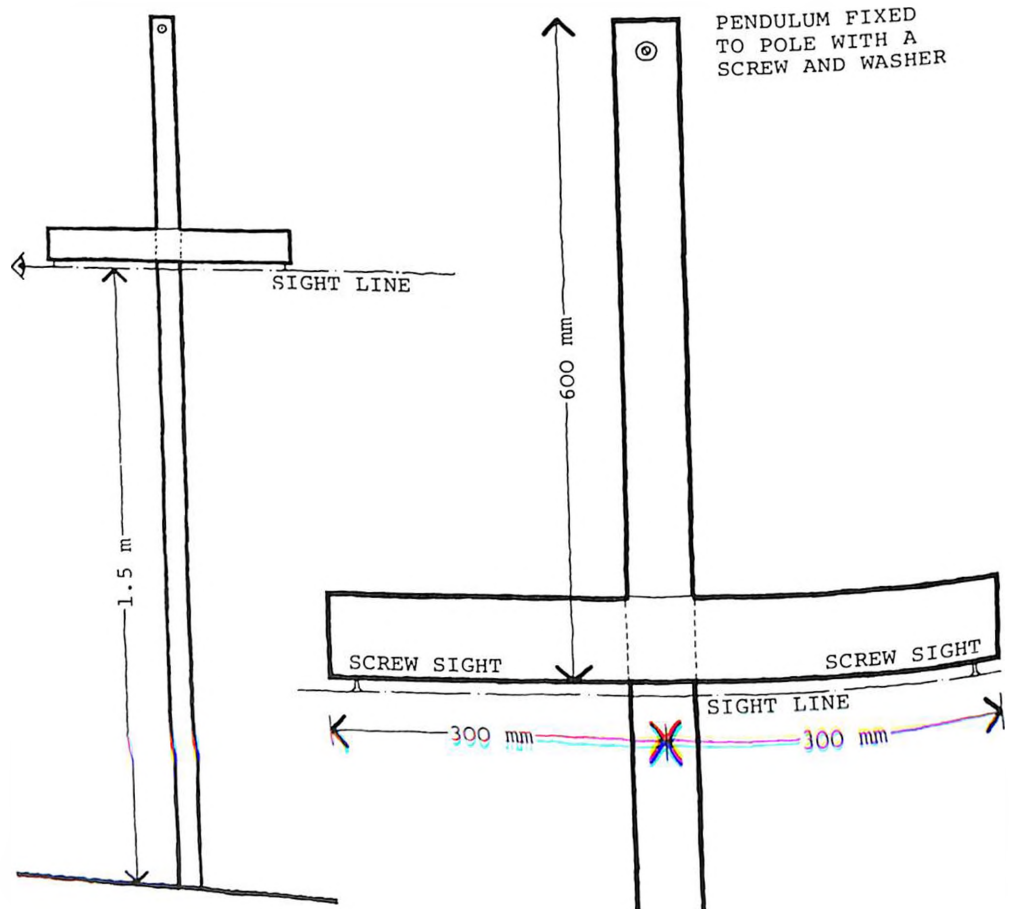

NOTE: THE T-SHAPED PENDULUM MUST BE ALLOWED TO SWING FREELY. IT CAN BE MADE ACCURATE BY ADJUSTING THE SCREW SIGHTS UNTIL THE READING ON A DISTANT OBJECT IS THE SAME WHEN SIGHTING FROM EITHER END OF THE LEVEL.

FIGURE 71  
levelling method

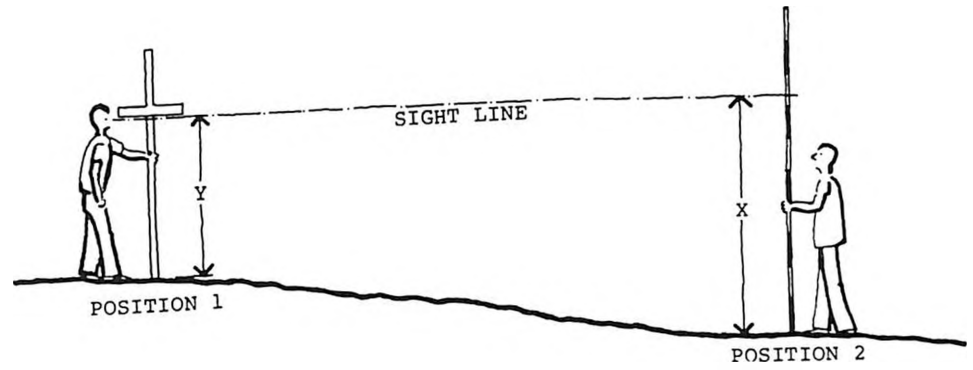

site characteristics

Other observations to be made on site and included on the survey drawing are:

- the general type of vegetation and the position of trees and shrubs and their condition
- the soil conditions and the presence of rock outcrops
- the presence of surface water in the form of streams, ponds or swamps
- the points of the compass and the direction of prevailing winds
- the position of existing buildings and their physical condition
- the position of existing roads and services and their size

All this information should be combined on a site plan drawn to a scale of preferably 1:200 which can be used as the basis for the master plan for the project.



APPENDIX THREE - ROOF TRUSSES

page 103

Figure 72 shows, in detail, two alternative roof truss designs the general features of which are described in Section Six of Chapter Five. Both trusses are designed to span 6.4 m at a spacing of 1.6 m and both have a slope of 1:3. The timber used is second grade softwood (cypress), the size of the members being shown on the drawing with a list of total amounts which can be used for ordering. The strength of the joints is important and the number of nails (50 mm long for the A-frame, 38 mm long for the lattice) required at each connection is shown. Half of the nails in each case should be driven in from one side and half from the other.

FIGURE 72  
roof truss designs

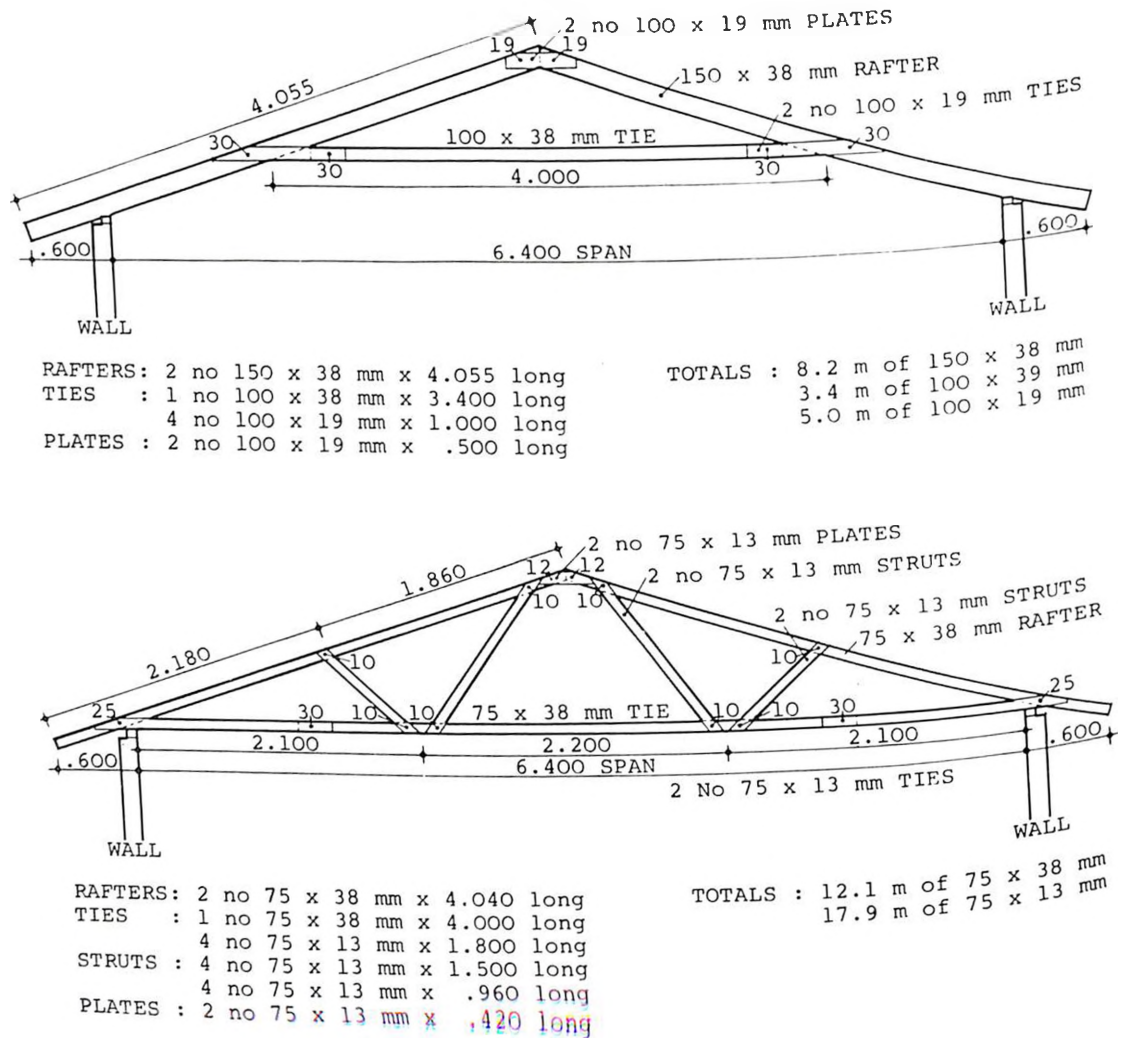

## APPENDIX FOUR - SHORT FORM CONTRACT

page 122

The following short form of contract is suitable for small and medium-sized projects up to a contract value of say K sh 300,000. It is a general form and each clause should be studied in conjunction with the notes on the contract set out in Section One of Chapter Seven. If any clause fails to meet the specific requirements of the project it should be modified or deleted. The contract wording assumes that no architect will be directly involved and that all matters are to be settled between the Employer and the Contractor with recourse (under clause 11) to a mutually appointed arbiter. If an architect is retained he should advise on the best form of contract to use.

SHORT FORM OF CONTRACT

ARTICLES OF AGREEMENT made the ..... THE DATE .....  
BETWEEN THE NAME OF THE EMPLOYER .....  
OF HIS ORGANIZATION AND ADDRESS .....  
(hereinafter referred to as "The Employer") of the one part and .....  
THE NAME OF THE CONTRACTOR .....  
OF HIS COMPANY AND ADDRESS .....  
(hereinafter referred to as "The Contractor") of the other part.  
WHEREAS the Employer is desirous of having THE NAME OF .....  
THE BUILDING OR WORKS TO BE UNDERTAKEN .....  
in accordance with the drawings numbered LIST OF DRAWINGS .....  
and the Bill of Quantities.

NOW IT IS HEREBY AGREED BY THE EMPLOYER AND THE CONTRACTOR AS FOLLOWS:-

amount of contract

1. The Contractor will execute and complete the works shown upon the drawings and described in the Bills of Quantities with materials and workmanship of the respective kinds described in the Bills of Quantities for the sum of  
CONTRACTOR TO INSERT FULL CONTRACT SUM .....

The Contract sum shall be deemed to have been calculated to include all duties on materials to be used in the works.

possession of site and completion

2. Possession of the site (or premises) will be given to the Contractor on or before the  
STARTING DATE .....

He shall begin the works immediately after such possession and shall regularly proceed with them, and shall complete the same by the  
PRACTICAL COMPLETION DATE .....

subject nevertheless to the provisions for extension of time hereafter contained.

damages for delay

3. If the Contractor shall fail or neglect to complete the works on or before the date stated in clause 2 hereof or by any extension of time given by the Employer, the Contractor hereby agrees to pay or allow to the Employer as and by way of liquidated damages and not by way of penalty, sum to be calculated at 10% of the value of any uncompleted sections, divided by 52 to give a weekly rate.

extension of time

4. If the works be delayed through any cause not under the control of the Contractor, the Employer shall make a fair and reasonable extension of time for completion of the works.

notices and fees

5. The Contractor shall comply with all rules, regulations and by-laws of any Local Authority, Water or Lighting Companies and shall conform to the provisions of any laws relating to the works and he must give all notices required by the said laws, rules, regulations and by-laws and pay all fees legally demandable.

variations

6. The Employer and Contractor agree that no variation shall vitiate the contract but that all variations involving additional expenditure shall be estimated by the Contractor and the estimate approved by the Employer before the work is executed.

injury to persons and property

7. (a) Injury to Persons. The Contractor shall be liable for and shall indemnify the Employer against all loss, claims or proceedings whatsoever whether arising in respect of personal injuries to persons whether in his employment or not arising out of or in the course of the execution of the contract and against all costs and charges incurred in relation to the investigation or settling of such claims.

(b) Injury to Property. The Contractor shall be liable for and shall indemnify the Employer in respect of any liability, loss, claim or proceedings and for any injury or damage whatsoever arising out of or in the course of the execution of the contract works to any property, real or personal, due to any negligence, or omission or default of himself, his agents or his servants or of any Sub-Contractor or to any circumstances within his control.

(c) The Contractor shall secure the due performance of these indemnities by forthwith entering into proper and sufficient policies of insurance.

defects

8. The Contractor shall make good at his own expense any defects, shrinkages, and other faults which may appear within six months from the completion of the works arising from materials or workmanship not in accordance with the contract.

provisional and prime cost sums

9. All provisional sums and prime cost prices mentioned in the specification for the execution of the works or for the supply of goods are strictly net and intended to be available in full for payment to the parties concerned. Prime cost sums shall include customs duty or other taxes and cost of packing, carriage and delivery.

payment

10. The Employer will pay to the Contractor the sum mentioned in clause 1 or such other sums as shall become payable monthly after the work done during the previous month has been executed in accordance with the contract and its value agreed by the contractor and the employer. Payments shall be made at the rate of 90%, the balance to be paid within six months after the works have been finally completed and all defects made good, whichever shall last happen.

arbitration

11. The Employer and Contractor agree that should any dispute or difference arise between them touching any matter concerning the works then either party shall forthwith give to the other notice of such dispute or difference and the same shall be referred to a third party agreeable to the Employer and the Contractor whose award shall be final and binding on all parties concerned.

AS WITNESS our hands this . . . . . DATE OF SIGNING . . . . .

SIGNATURE . . . . .  
Witness

SIGNATURE . . . . .  
Employer

SIGNATURE . . . . .  
Witness

SIGNATURE . . . . .  
Contractor

## APPENDIX FIVE - BUILDING INSPECTION CHECK LIST

The sample check list (Figure 73) is designed for use at the inspection carried out before occupation of the building and again at the end of the defects liability period. The value of a check list is as a reminder to examine each item in every room and also to provide a written record of the defects which must be made good before the retention sum is released. The four main areas for checking are:

surface

This applies mainly to floors, walls and ceilings and to a limited extent to fixtures such as cupboards and work tops. The general surface quality of each item should be checked for cracks, undue roughness, colour and cleanliness. In the case of large surfaces, particularly floors, a 3 m straight edge should be laid across them to make sure that they are flat.

position

This applies mainly to doors, windows and all fittings, although some times partition walls are not properly positioned. Both horizontal and vertical positioning should be checked especially for work tops, shelving, window openings, and electrical and water outlets.

installation

This applies only to fittings, furniture and service equipment, and is mainly a matter of checking fixings. The installation of specialized equipment such as X-ray machinery, where safety is involved, must be inspected by an expert. Water and drainage equipment should be checked for leaks and electrical outlets for loose connections.

operation

This simply involves the testing of all working items. Taps should be run, toilets flushed and switches tried. Doors and windows should be opened and closed checking for smooth operation of the hinges and the safety of catches and locks.

After each room and corridor has been inspected and either approved or noted for further attention, the outside walls and roof should be examined for soundness and appearance. The outside features of doors and windows should also be checked.

Both inspections should be carried out with the contractor present and any defects agreed with him as they arise.



The sample sheet is filled out for a hypothetical job. It is to be hoped that there would never be as many remarks as indicated here for a single room; it is intended only to give an idea of the kind of problems that can arise.

FIGURE 73  
building inspection check  
list

BUILDING INSPECTION CHECK LIST - INTERNAL NEW MATERNITY UNIT — HOSPITAL						APPROVED	
ROOM NAME: DUTY ROOM						1	2
Checked by: A. W. W.						Final Insp. AUG 1ST	
Checked by: A. W. W.						1st Insp. FEB 1ST	
ITEM	SURFACE	POSITION	INSTALLATION	OPERATION	GENERAL		
FLOOR + skirtings	MORE THAN 22 mm VARIATION IN FLOOR LEVEL						
WALLS + screens	CRACKS ABOVE LEFT SIDE WINDOW						
CEILING		SAGGING AROUND LIGHT FIXTURE			SOME COVER BEADS ARE LOOSE		
WINDOWS + fittings	PAINT SPOTS ON GLASS		WINDOW BOARD LOOSE	LATCH BROKEN			
DOORS + fittings			TWO HINGES PER DOOR NOT THREE AS SPECIFIED		KEY MISSING		
FIXTURES + fittings	UNDERCOAT ONLY ON SHELF OVER SINK		COVER PLATE LOOSE		CABINET WORK NOT TO STANDARD OF SAMPLE UNIT		
ELECTRICITY lights & sockets				TAP DRIPPING	EXPOSED WIRING ACROSS CEILING		
WATER SUPPLY pipes & outlets		TAPS TOO LOW OVER SINK					
DRAINAGE outlets & pipes			GRILLE MISSING FROM OUT-LET	WASTE SLOW IN CLEARING			

## APPENDIX SIX - METRIC/IMPERIAL EQUIVALENTS

All measures in this manual are given in metric units, that is to say in metres (m) and millimetres (mm) for linear measurement, and litres and cubic metres (m<sup>3</sup>) for volumetric quantities. It is however appreciated that imperial measures (feet, inches, gallons and cubic yards) are still in use in some areas and that many common building materials are made to imperial dimensions. For this reason the following approximate equivalents are given.

length	1 mile	=	1.61	kilometres (km)
	1 yard	=	0.91	metre (m)
	1 foot	=	305	millimetres (mm)
	1 inch	=	25	millimetres
area	1 sq. mile	=	2.59	km <sup>2</sup>
	1 acre	=	0.405	hectares (ha)
	1 sq. yard	=	0.84	m <sup>2</sup>
	1 sq. foot	=	0.093	m <sup>2</sup>
	1 sq. inch	=	645	mm <sup>2</sup>
volume	1 cu. yard	=	0.76	m <sup>3</sup>
	1 cu. foot	=	0.028	m <sup>3</sup>
	1 UK gallon	=	4.5	litres
	1 pint	=	0.57	litres
mass	1 ton	=	1.02	tonne
	1 ton	=	1,020	kilograms (kg)
	1 pound	=	0.45	kilograms
metric equivalents	1 kilometre	=	1,000	metres
	1 metre	=	1,000	millimetres
	1 metre	=	100	centimetres
	1 km <sup>2</sup>	=	100	hectares
	1 ha	=	10,000	m <sup>2</sup>
	1 m <sup>3</sup>	=	1,000	litres
	1 litre	=	1,000	millilitres

## REFERENCES

The following references have been used in the compilation of this manual. Those marked with an asterisk are especially recommended for consultation in building medical facilities in conditions of limited resources.

- \* 1. The Rural Hospital  
R. F. Bridgman  
W.H.O. Monograph Series No 21
2. Hospital Planning and Administration  
Llewelyn-Davies and Macaulay  
W.H.O. Monograph Series No 54
3. District Hospitals in Kenya, Type Drawings (Report)  
District Hospital Planning Group  
Ministry of Works, Nairobi, Kenya
4. Botswana, Low Cost Building for Rural Health Facilities  
J. Skakke  
Housing Research and Development Unit  
Nairobi, Kenya
5. Hospital Design and Function  
E. Todd Wheeler  
McGraw Hill, U.S.A.
6. Hospitals Clinics and Health Centres  
Goble  
Architectural Record, U.S.A.
7. Ziekenhuizen (Hospitals)  
Bouwcentrum  
Rotterdam, Holland
- \* 8. Medical Care in Developing Countries  
Maurice King  
Oxford University Press, England
9. Hospital Legislation and Hospital Systems  
Bridgman and Roemer  
W.H.O. Public Health Papers No 50
10. **Obstetrics and Gynaecology in the Tropics**  
Lawson and Stewart  
Arnold, England
11. Operating Theatre Technique  
Raymond Brigden  
Livingston
12. Health Care for Remote Areas  
James P. Hughes  
Kaiser Foundation, U.S.A.
13. Planning for Health  
Michael Colbourne  
New Africa Library
14. Medical Development in the Southern Sudan (Report)  
African Medical and Research Foundation  
Nairobi, Kenya
15. Health Sectors of Kenya and Tanzania (Report)  
J. Korn  
Institute of Development Research  
Copenhagen

- |   |   |
|---|---|
| 16. Medical Development in Botswana (Report)  | African Medical and Research Foundation<br>Nairobi, Kenya                               |
| * 17. A Manual on Building Construction   | Rev. H. K. Dancy<br>Intermediate Technology Group, London                               |
| 18. Field Engineering   | F. Longland<br>Govt. Printers, Dar-es-Salaam  |
| 19. Handbook for Building Homes of Earth  | Department of Housing and Urban<br>Development, Washington, D.C.                        |
| 20. Better Burnt Bricks   | T. I. Svare<br>National Housing and Building Research<br>Unit, Dar-es-Salaam            |
| 21. Timber in Tropical Building   | Overseas Building Notes No. 146<br>B.R.S. Watford, England                              |
| 22. The Construction of Farm Buildings (Report)   | Kristoffer Haugum<br>Embu Institute of Technology, Kenya                                |
| * 23. Water Treatment and Sanitation  | Mann and Williamson<br>Intermediate Technology Group, London                            |
| * 24. Smallwater Supplies   | Ross Institute Information and Advisory<br>Service, Bulletin No 10                      |
| * 25. Rural Sanitation in the Tropics   | Ross Institute Industrial Advisory<br>Committee, Bulletin No 8                          |
| 26. Roof Slopes for Low Cost Structures (Report)  | J. Eygelaar<br>Housing Research and Development Unit<br>University of Nairobi, Kenya    |
| 27. Roof Structures for Low Cost Housing, Cost Comparison for Various Roofing Materials | J. Eygelaar<br>Housing Research and Development Unit<br>University of Nairobi, Kenya    |
| 28. B.R.U. Data Sheets (Reports)  | National Housing and Building Research<br>Unit, Dar-es-Salaam                           |
| 29. Site Planning   | Kevin Lynch<br>M.I.T. Press, Boston, U.S.A.   |
| 30. Design for Climate (Report)   | Charles Hooper<br>Housing Research and Development Unit<br>University of Nairobi, Kenya |
| 31. Architect's Data  | Neufert<br>Crosby Lockwood, England   |
| 32. A. J. Metric Handbook   | Fairweather and Sliwa<br>• Architectural Press, London                                  |

