

012
TITLE

Cane sugar and its industry in Kenya.

The manufacture of 'raw cane sugar'.

'A SUGAR FACTORY'.

UNIVERSITY OF NAIROBI
LIBRARY

UNIVERSITY OF NAIROBI LIBRARY



0238833 8

UNIV. OF NAIROBI, REF. ONLY

UNIVERSITY OF NAIROBI
LIBRARY

Ed 283619

CANDIDATE _____

THE UNIVERSITY OF MICHIGAN LIBRARY

T. Mutuku Kitaha,

Master of Architecture 2,

Department of Architecture,

University of Nairobi.

Academic Year 1972/73.

A Thesis submitted in part fulfilment of the
Degree of Master of Architecture in the
University of Nairobi.



This thesis is my original work and has not
been presented for a degree in any other
University.

Signed:

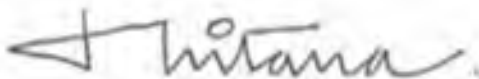
A handwritten signature in cursive script, appearing to read 'T. Mutuku Kitana', written in dark ink on a light background.

T. Mutuku Kitana



This thesis has been submitted for examination
with my approval as University Supervisor.

Signed:

Professor, Dept. of Architecture.

AIM

.01. To get involved in a programme that can within the next seven months and a half end up with a thesis and project suitable for the award of the degree of Master of Architecture of the University of Nairobi.

.02 Conditions and regulations are as laid down by the department of Architecture of the University of Nairobi and the higher degrees committee of the same University.

PREAMBLE _____

.01 For a thesis or any research work to have any meaning at all it must be occasioned.

.02 Any of its findings and recommendations should be of service to the human race as a whole or to the area in which such an exercise has been carried out.

.03 Hence the need for background study to establish relevant problems.

.04 I therefore found it fit to spend some time doing preliminary findings to enable me to pinpoint areas of our (Kenya) economy where I could spend the next seven months carrying out an exercise that could be of benefit to this country.

.05 The subject to be chosen had to have enough architectural content/quality to merit its authorship from a candidate presenting himself for an architectural degree.

CONTENTS:

.01	FRONT PAGES	Pages - - - - I to 33.
.02	CHAPTER ONE	Pages - - - - I to 33
.03	CHAPTER TWO	Pages - - - - 34 to 47.
.04	CHAPTER THREE	Pages - - - - 48 to 63.
.05	CHAPTER FOUR	Pages - - - - 64 to 89.
.06	CHAPTER FIVE	Pages - - - - 90 to 105.
.07	CHAPTER SIX	Pages - - - - 106 to 118.
.08	CHAPTER SEVEN	Pages - - - - 119 to 147.
.09	CHAPTER EIGHT	Pages - - - - 148 to 170.
.10	CHAPTER NINE	Pages - - - - 172 to 181

FRONT PAGES:

TITLE OF THESIS

CANDIDATE

DEGREE

DECLARATION

CHAPTER ONE'

Pages I-33

BACKGROUND STUDIES

Part i. Problem Establishment

Part ii. Kenya's Agricultural Potential

Part iii. Problems in Agricultural Industry

Part iv. Agricultural Institutions.

CHAPTER TWO

Pages 34 to 47

SUGAR AS A COMMODITY

- 1.00 A by the way
- 2.00 Economics of sugar
- 3.00 Sugar Industry in E. Africa
- 4.00 Policy issues for the future expansion of
the Sugar Industry.
- 5.00 Cost determinants
- 6.00 By-products of the Sugar Industry.
- 7.00 Side factories
- 8.00 Sugar production potential forecast in Kenya.

CHAPTER THREE

Pages 48 to 63

MANUFACTURE OF RAW SUGAR

- 1.00 Harvesting
- 2.00 Transportation
- 3.00 Weighing
- 4.00 Milling
- 5.00 Liming
- 6.00 Clarifying/Filtering
- 7.00 Evaporation
- 8.00 Pans
- 9.00 Crystallization
- 10.00 Centrifuging
- 11.00 Bagging
- 12.00 Sugar Storage

CHAPTER FOUR

PAGES 64 to 89

PLANT LAYOUT

- 1.00 General Objectives
- 2.00 Requirements for Machinery
- 3.00 Weight
- 4.00 Process requirements
- 5.00 Requirements for Materials
- 6.00 Movement
- 7.00 The Factor Man
- 8.00 Psychological or Personal considerations
- 9.00 Organisation & Supervision
- 10.00 Services
- 11.00 Offices/Administration

CHAPTER FIVE

Pages 90 to 105

LOCATION OF THE SUGAR FACTORY

- 1.00 Sugar cane growing areas and the agricultural policy.
- 2.00 Proximity to raw materials.
- 3.00 Availability of power.
- 4.00 Transportation arteries.
- 5.00 Government policy (zoning & pollution control)
- 6.00 Planning of plantation.
- 7.00 Labor & training.

CHAPTER SIX

Pages 106 to 118

THE OVERALL LAYOUT OF THE FACTORY SITE

- : In relation to movement - (transportation).
- : In relation to services.

CHAPTER SEVEN

Pages 119 to 147.

THE FACTORY BUILDINGS

- 1.00 The manufacturing spaces
- 2.00 Storage spaces
- 3.00 Laboratory spaces
- 4.00 Service spaces
- 5.00 Maintenance spaces
- 6.00 Supervision and Administration
- 7.00 Welfare spaces.

CHAPTER EIGHT

Pages 148 to 170.

CHAPTER NINE

Pages 172 to 181

THE BUILDING BRIEF.

HOUSING AND SOCIAL FACILITIES.

CHAPTER ONE

These opening pages are devoted to studies which form the background investigation before the choice of the subject for my thesis and project.

The analysis is divided into four parts namely:-

- : Part i. Subject choice
- : Part ii. Kenya's Agricultural potential
- : Part iii. Problems in Agricultural Industry
- : Part iv. Agricultural institutions in Kenya.

Part 1. - Subject Choice

A discussion under the heading listed below:-

- 1.00 Score for the thesis & project.
- 2.00 Subject choice procedure.
- 3.00 The development plan.
- 4.00 5 years working experience.
- 5.00 Agriculture in Kenya.
- 6.00 Agricultural history & development in Kenya since independence.

1.00 Scope for the thesis and project-

.01 At the beginning of the year the department of architecture put forward its wish that subjects/topics chosen for ones thesis and project should be derived from the current development plan(s) so that the final product can be of meaning to the author. It could also be of use to the country if steps to implement it are taken.

.02 Such a suggestion did not rule out the possibility for a candidate to tackle an entirely hypothetical problem.

2.00 Subject choice procedure _____

.01 I ruled out the idea of doing a hypothetical exercise.

.02 So I dug into the only remaining source of information - the development plan - where I made a thorough analysis of the development targets as a whole.

.03 Later on I emphasized on the physical development targets that were relevant to my field of study.

3.00 The Development Plan _____

.01 In this document all the Government Ministries had outlined their development targets in terms of policy and also actual physical facilities they intend to realize during their term of office.

.02 Such Ministries like Labor, Lands and Settlement, Foreign Affairs, Commerce and Industry etc. have much to do with policy making than provision of actual physical facilities.

.03 But Ministries like Housing, Education, Agriculture, Communications & Power etc. extend their policy making to the actual provision of physical facilities.

.04 Though it is through the Ministry of Works that the physical building work is done, it is these various Ministries that formulate the brief and later on run the facilities when they are in operation.

4.00 5 years working experience. _____

.01 In the past five years I have been involved in programmes embracing such topics like Housing, Education, Medical, Communication and even Tourism.

.02 The only important subject that I have never been involved in is Agriculture.

.03 Being at the peak of my academic career I therefore found it fitting (or say inevitable) that I carry out an exercise in a field on which our (Kenya) economy is basically founded.

5.00 Agriculture in Kenya. _____

.01 Agriculture is the most important component of Kenya's economy.

.02 The above statement is backed by statistics showing how much Agriculture contributes to both Gross Domestic Product, Exports, and employment in Kenya.

.03 Agricultural incomes provide greater savings and foreign exchange needed for development and in creating expanded markets for goods produced in the non-agricultural sectors of the economy.

6.00 Agricultural history and
development in Kenya since independence

.01 Immediately after independence the Kenya Government's greatest efforts in agriculture were directed to land transfer and resettlement programmes.

.02 $\frac{1}{3}$ of the agricultural budget in 1963/64 was spent on these functions only.

.03 Quotable examples include the million acre scheme.

.04 In this exercise both small scale and large scale farms were involved.

.05 Here it is interesting to note that due to lack of capital and management know-how (on the part of Africans who took over) it was mainly the mixed farms that changed hands during this period.

.06 These were taken over in bulk by co-operatives or by individuals after subdividing.

.07 But it was later realized that production had dropped since the take-over of these farms. Some people had even resold their farms etc.

6.00 Agri. dev. contd

.08 Another sad thing was that the majority of the new settlers had not paid back their loans as formally agreed.

.09 Thus at this particular juncture it was realised that agricultural education embracing both the technical & managerial spheres was vital for the new farmers.

.10 Farmers training colleges, the co-operative college in Kenya, the Japanese aided technical/mechanical school in Nakuru are a few examples of such education.

.11 It is only through increased agricultural efficiency especially in production & marketing that the new farmers can repay back their loans.

.12 Thus during the present controversial movement of people from over crowded to less crowded and agriculturally productive areas, the Agricultural Development Corporation and the Agricultural Finance Corporation (A.D.C. & A.F.C.) are charged with the

6.00 Agri. dev. contd.

responsibility of assisting the settlers in all ways until they can run their farms profitably.

.13 Extensive research is being done to increase the production efficiency say per acre so that farmers don't lose when they accept lower prices due to competition from elsewhere.

.14 Also interesting is some work being done to bridge the gap between hand cultivation and tractor cultivation. Capital costs in farm machinery have been labelled as the greatest consumers of a farmer's production investment.

.15 Work on better communication between agricultural areas and export ports like Mombasa is in progress.

.16 More important consideration being done is the provision of storage facilities at both ends e.g. say in the case of maize - silos.

.17 Statutory board procedures are under serious review for purposes of re-organisation in order to

6.00 Agri. dev. contd.

increase the actual income of the farmer unfairly reduced organisational red tape.

.18 An interesting development is the selective increase in the production of some potential agricultural products e.g. maize, rice, sugar etc. and the discouragement of those products with synthetic competitors e.g. pyrethrum, cotton etc.

.19 Thus the reason for the great effort of the Ministry of Agriculture is extending its irrigation schemes.

part ii. Kenya's Agricultural

Potential. _____

Looks into Kenya's agricultural potential under its two main sectors namely:-

- : Crop Agriculture
- : Livestock Agriculture

CROP AGRICULTURE

Kenya's varied climate makes it possible for a variety of crops to be grown here.

Both cash crops and subsistence crops are to be found.

The following pages discuss the various crops or crop species.

Discussion is centred on the production of each and its future prospects especially with regard to world markets.

1.00 Pyrethrum

.01 This crop had in the past contributed over 80% to the insecticide production.

.02 But recent developments in science have resulted in producing synthetic insecticides which offer a very big competition to pyrethrum growing.

.03 Pyrethrum farmers in Kenya cannot therefore extend their farms in a bid to produce more.

.04 The only way Kenya farmers can counter the competition from synthetics is to increase their production efficiency by say producing more per acre or producing pyrethrum with a higher percentage of pyrethrin in its flowers.

.05 By doing so they can be able to accept lower prices for their stuff and still realize profits.

.06 It is only in this way that they can compete with the cheaply produced synthetic insecticides.

.07 The Kenya Government is already spending some

Pyrethrum contd. _____

money on research to see how best they can elevate production efficiency in the direction pointed out above.

2.00 Coffee_____

.01 The story of coffee is an old one. The world quota system has made it impractical for Kenya to encourage farmers to produce more coffee though there is land and good climate.

.02 Some farmers have been known to unroot their trees due to lower prices offered for the crop.

.03 Infact there is a likelihood of there being enormous amounts of surplus coffee and the Government is looking into the possibility of erecting storage facilities.

3.00

Tea

.01 Tea has also got the problem of this quota system.

.02 But since this is not as great a threat as is with coffee the Government is still encouraging increased production.

.03 But this production increase is only by the small scale farmers. No big farms are being established.

.04 The Government has therefore planned to build 9 small tea factories to cater for this expansion.

4.000 Signal

.01 Here there is an increasing competition from synthetics.

.02 There therefore is no plan at all to expand its production.

5.00 Sugar



-
- .01 In Kenya sugar consumption exceeds production.
 - .02 There is need to expand production at factory level in the four existing sugar factories.
 - .03 But after a short while these factories will reach their maximum capacity.
 - .04 Therefore the increased demand for sugar can only be met by establishing new plantations and factories.
 - .05 Already plans are under way to establish another sugar factory in Mumias.
 - .06 Experimental sugar growing in this area (Mumias) has been carried out since 1967 and it has shown great success.
 - .07 Even when this scheme is in full operation it is still doubtful whether it will enable Kenya to be self sufficient in sugar and also export sizable quantities to earn the possible foreign exchange.
 - .08 Sugar industry seems to have a bright future.

9.00 Sugar contd.

.09 It looks like we need a well organised programme to even produce enough sugar for local consumption.

.10 A deeper discussion (Economic & Industrial) on sugar will follow later when I get to the backbone of my thesis/project under the possible titles "Sugar production & its processing in Kenya" or "Sugar production and its industry in Kenya".

6.30 Maize and other cereals _____

- .01 Here the problem is production at low cost.
- .02 farm machinery in big maize plantations cost nearly fifty percent of the production costs.
- .03 There are as mentioned earlier plans to carry out research on cheaper methods of cultivation.
- .04 Better maize hybrids are being worked on to increase production at the different climatic conditions.
- .05 The only setback there is in maize production in the availability of storage facilities.
- .06 These facilities should be provided at the production areas and also at Mombasa where storage could take place before exporting.
- .07 Also necessary to look into is the transportation facilities between the two ends.
- .08 Here I am talking about the erection of silos & bulk transportation vehicles.

6.00 Maize and other cereals contd. —

.09 As concerns other cereals there is not very much to say.

.10 These are only cultivated for subsistence purposes.

.11 Notable exceptions are wheat and rice but these two have not fully established themselves in the African menu.

.12 But wheat finds sizeable market in the beer industry.

LIVESTOCK AGRICULTURE

Potentially Kenya is capable of maintaining a greater herd than it is doing at present.

A look at Kenya's herd under its two main categories namely 'dairy' & 'beef' herds follows in the next pages.

1.00 The dairy herd

-
- .01 Kenya is short of enough dairy herd.
 - .02 Farmers have to keep cows that produce little milk because there are not enough good milkers.
 - .03 Plans are under way to import better dairy cows.
 - .04 Also artificial insemination is being emphasized in order to improve stock.
 - .05 There is already research going on concerning both better stock and planning of milk processing.
 - .06 During this development plan there are plans to build two new milk processing plants at the cost of £500,000.
 - .07 Also research on disease control & diagnosis, methods production of vaccines etc. are being carried out.
 - .08 This research work is to be carried out in the cattle producing areas but not in the rather too crowded Kabete laboratories where it has always

1.00 The dairy herd contd. _____

been done. Thus more research stations are to be established.

2.00 The beef herd.

.01 Here the target is to get the herd fattened in the shortest possible time.

.02 Beef finishing projects are to be set in the country to establish the best & quickest methods of doing so.

.03 Research in disease control etc. is being extended in the same way as for the dairy herd.

Part 111. Problems in Agricultural
Industry. _____

Here is a summary of the main problems facing the
Agricultural Industry:-

: Production problems

: Marketing problems.

1.00 Production problems

-
- .01 Lack of skills on the part of the farmer.
 - .02 Lack of materials e.g. dairy cattle etc. - farmers have to keep less productive commodities e.g. sheep & goats.
 - .03 Equipment for cultivation - there is need to extend loan payment time for farm equipment so that farmers' pockets are not emptied by machinery only.
 - .04 Also needed is aid in training & financing of machinery contractors.
 - .05 Water resources shortage is a big problem. Farmers have to drive their herd for distances in search of water.
 - .06 Crop failures occur due to lack of irrigation facilities.

2.00 Marketing problems. _____

- .01 An increase in the production of synthetic alternatives has reduced the market for some of our raw materials.
- .02 Also damaging is the poor management of co-operatives leading to reduced earnings by the producer (the farmer).
- .03 Poor transport facilities from the farm to the factory leads to both damaging of the commodities and delay in the processing activity.

Part IV. Agricultural Institutions
in Kenya. _____

Several institutions have been established to be guardians of agricultural development in this country. These include:-

- 1.00 The Agricultural Development Corporation.
- 2.00 Agricultural Credit.
- 3.00 Agricultural Education.

These and their basic programmes are outlined in the next pages.

Also The Agricultural Development
Commission (the A.D.C.) and its
programmes. _____

.01 This body controls many large scale farms in Kenya.

.02 Some of these it leases to farmers.

.03 The rest are retained for use together with some other five established National farms for the production of certain important agricultural inputs which are in short supply e.g. breeding stock (cattle & pig) and improved crop seeds.

.04 Also in team with commercial banks the A.D.C. intends to engage in such projects e.g. heifer production and continue to be government agency in factories of agricultural processing e.g. the sugar factories in Chemilil & Muhoroni.

2.00 Agricultural Credit.

.01 This is a credit facility establishment from which farmers get financial/material help.

.02 It is a government facility but it is run by the three agents namely:-

: The Agricultural Development Corporation (A.D.C.)

: The Agricultural Finance Corporation (A.F.C)

: The Kenya National Trading Corporation (K.N.T.C.).

.03 Loan facilities are on two basis:-

: Credit for large scale farmers

: Credit for small scale farmers.

.04 At present there is a move to have small scale farmers credited by co-operatives.

.05 Such a move is intended to ease the backpayment of the loans because the procedure would be that of deducting backpayment amounts from ones earnings at his local co-operative society.

3.00 Agricultural Education _____

.01 Highest in Kenya are the two facilities of Agriculture and Veterinary Science in the University of Nairobi.

.02 At the intermediate level are:-

: Egerton College - which turns out middle class agricultural technicians.

: A.H.I.T.I. - specialized in animal husbandry.

: Embu Farmers Institute - for farming courses.

.03 There are also farmers training/refreshers centres which form the lowest category.

.04 All these institutions need expansion. Most vital is establishment of more farmers training centres.

.05 There are hopes of a world bank loan for this purpose.

CHAPTER TWO

SUGAR AS A COMMODITY

The discussion here is divided into several headings namely:-

- 1.00 A by the way.
- 2.00 The Economics of sugar.
- 3.00 Sugar ^{Industry} Insutry in E. Africa.
- 4.00 Policy issues for the future expansion of the sugar industry.
- 5.00 Cost determinants.
- 6.00 By-products of the sugar industry.
- 7.00 Side factories.
- 8.00 Sugar production potential forecast in Kenya.

1.00 A by the way _

.01 The word "SUGAR" has in the past been regarded as a word of endearment and affection.

.02 It has remained synonymous with "HONEY" when loved ones are addressing each other.

.03 But to the weight conscious consumer today, it is a word to induce mistrust.

.04 Propaganda has it that artificial sweets in coffee and tea desserts help to keep one slim forever, pimple free and happy.

.05 Due to this discredit, people brand sugar as the cause for diabetes, heart attack and bad teeth.

.06 Consequently most 'modern' homes keep artificial sweets: women carry them in handbags and men carry them in their pockets.

.07 A discussion on "sugar as a diet of man" and "the chemistry of sugar" are beyond the scope of this thesis.

2.00 The Economics of sugar _____

.01 Sugar can be regarded as a luxury but essential commodity.

.02 People who do not normally consume sugar will do so when their incomes go up.

.03 Thus, "the amount of disposable income will determine the demand for sugar".

.04 Therefore in economics terms as far as sugar is concerned, "the income elasticity of demand is elastic".

5.00 Sugar Industry in East Africa

- .01 The demand for sugar here is greater than supply.
- .02 The yield per one is low when compared with other countries.
- .03 Also the industry is characterised by short term labor contracts of workers (unskilled) who after earning some cash for one or two months quit their jobs for no known reasons.
- .04 Very little research has been carried out to establish ways of cutting down wastes through the introduction of by-products manufactured from waste products of sugar.
- .05 As concerns the pricing of the finished sugar this is governed by a "Commonwealth Agreement Price Act".
- .06 But the individual governments fix their own prices.
- .07 Distribution is by the various state trading Corporations.

5.00 Sugar Industry in E.A. contd. _____

.08 As mentioned earlier demand for sugar in E.A. is greater than supply. But this is only true for Kenya and Tanzania. Uganda exports some.

.09 Almost all the manufacturing, (factories & plantations) are operated and owned by private companies but the government own shares.

.10 At the time of submitting this thesis the sugar surplus situation in Uganda has already changed considerably.

.11 Due to the expellation of non-citizens from Uganda the sugar factories there (formerly owned by Asians) have temporarily dropped their output considerably and consequently all the East African countries are now importing vast quantities of sugar from overseas.

4.00 Policy issues for the future
expansion of the sugar industry. _____

.01 The future of the industry will depend on whether the return from sugar of the capital employed is greater than or less than uses of capital in East Africa.

.02 One can say that this will depend on whether costs in East Africa compare favorably with those of other countries.

.03 But incase outside prices are cheaper there might be need for government to restrict importation to protect the local industries (though how local they are is still a big question).

7.00

Cost determinants

.01 In East Africa low costs are favored by such factors e.g.

: Long harvesting seasons to keep the machines busy for most of the year.

: Low opportunity costs for land and labor.

.02 But costs go high through such things like:-

: High opportunity costs for machines, fuels, fertilizers & chemicals.

: Unskilled & unreliable labor and management personnel.

6.00 By-products of the sugar industry

.01 The inclusion of by-products plants within the sugar factory can help to increase earnings for the industry.

.02 For instance MOLASSES can be distilled for medical spirits or for alcohols used in gin distilleries and some sold as cattle feeds.

.03 Other by-products from Molasses e.g. acetone, butanol citric acid, lactic acid and dried yeast can be marketed locally if produced.

.04 In addition to chemical products other commodities including sugarcane wax, carbon paper, floor wax & other wax products can be produced in fair amounts from wastes from sugarcane.

.05 Bagasse - the fibrous cane waste is at present mostly used for fuel (in the factories boilers) but could be used as packing material and for making building material such as hard board and insulation.

6.00 By-products of the sugar

industry contd. _____

.06 Sweets can also be produced as a by-product of a sugar factory. Infact one factory in Uganda (Kakira Sugar Mills) is already producing a large variety of popular confectionary.

.07 But as indicated earlier there is great necessity to carry out research to establish economical methods of manufacturing these by-products. Indeed since most of these by-products are not even manufactured the point number one should be to investigate the feasibility of such a complex.

7.00 Side factories.

.01 Sometimes there occurs what is known as a "Factory Empire".

.02 This is in the form of small factories developing within the precincts of a mother factory.

.03 E.g. within or around Madhvani's Kakira Sugar Factory in Uganda are found:-

: An edible oil mill

: A margarine and vegetable ghee plant.

: A soap factory

: A metal container plant

: A maize mill & sweet factory.

.04 Although these are not from by-products of sugar their presence can help to keep the factory site lively during a low cane season.

8.00 Sugar production potential
forecast in Kenya. _____

.01 During the period 1966-1970 it had been forecast that increase in sugar production would be by extending the then two existing (old established) factories namely:-

: MIWANI in Nyanza and

: RAMISI in the coast.

.02 But during the same period (due to increased consumption) two more factories had to be established in Muhoroni and Chemelil.

.03 By 1974 the four factories are expected to produce a total of 165,000 metric tons of sugar (of. 81,000 metric tons of sugar they produced in 1968).

.04 This production increase will be due to an increase by 40% of the cane plantation area (an increase to 40,000 hectares compared to 29,000 hectares in 1968).

.05 An increase in factory efficiency will also contribute to the increased production.

8.00 Sugar production potential

forecast in Kenya contd. _____

.06 And about £600,000 worth of new equipment will add to production capacity in the new factories.

.07 Better transport arrangements between plantations & factory will help to curb overmature cane reaching the factory.

.08 To get to the point, a look at the figures shown that in 1968 though Kenya consumed 132,000 metric tons of sugar its production was 81,000 metric tons (i.e. 62% of consumption.)

.09 In the light of this by 1974 consumption will be in the region of 170,000 to 180,000 metric tons.

.10 At this point it is important to note that the above figure has been forecast as the strenuous maximum capacity production of the existing four factories.

.11 Thus if consumption increases by 1974 the four existing factories will not be able to cater for it.

8.00 Sugar production potential
forecast in Kenya contd. _____

.12 If therefore an additional sugar scheme is started its products would find more than ready market.

.13 In fact with this in view a pilot sugar project was started in Mumias in 1967 and there is already a report on how it will develop into a full scale commercial project.

.14 Experiments have shown that sugarcane grows better in Mumias than in the other existing areas.

.15 Cane in this scheme is almost mature and the first harvest is expected by the middle of 1973.

.16 Simultaneously, construction of the factory to mill this cane is at its advanced stages and is expected to start operating by June 1973.

.17 The estimated cost of the scheme is £7 million and the government is contributing £3.3 million. The rest is supposed to come from private interests.

.18 But according to unpublished reports (unofficial)

8.00 Sugar production potential

forecast in Kenya contd. _____

Kenya is importing fantastic amounts of sugar.

.19 This great shortage pressure has even been felt by the Government because they have in recent months set up a commission to investigate the possibility of setting up another sugar industry in South Nyanza.

.20 A full report on this project is not yet out.

.21 But according to the chairman of the sugar authority, Kenya is far from being self sufficient in sugar.

.22 In fact we are importing over 130,000 metric tons of sugar yearly (Daily Nation report Nov.1972).

.23 An additional factory in South Nyanza would reduce this acute shortage even before we could think of erecting our own refinery for white sugar.

CHAPTER THREE

THE MANUFACTURE OF RAW SUGAR

the manufacturing process

This chapter outlines the process raw cane goes through from the time it is harvested from the plantation, is transported to the factory, is milled and then transformed into raw sugar which is either stored or transported to the various distributing centres.

For convenience and clarity the discussion is divided into the various distinguished processes or process stations that occur during the manufacture - namely:-

- 1.00 Harvesting
- 2.00 Transportation
- 3.00 Weighing
- 4.00 Milling
- 5.00 Liming
- 6.00 Clarifying/Filtering
- 7.00 Evaporation
- 8.00 Pans

manufacturing process contd. _____

9.00 Crystallization

10.00 Centrifuging

11.00 Bagging

12.00 Sugar storage

1.00 Harvesting —

.01 In this country most of the harvesting is done by hand using cane knives.

.02 This is due to the availability of cheap manual labor.

.03 But there is a certain percentage of mechanical harvesting done though the machines used are not fully developed to combined harvesters.

.04 They exist as separate cutting and loading machines.

2.00 Transportation

- .01 The harvested cane is loaded onto transportation trailers by front grabbing tractor cranes.
- .02 These transporting trailers are in the form of big carts pulled by tractors.
- .03 The above transportation system applies only to the nucleus estate.
- .04 The outgrowers estates transport their cane in big lorries.
- .05 For quick and unencumbered unloading the transportation trailers are designed so that they can be side tipped.
- .06 Such a design makes it possible for the trailer to be driven right next to a conveyor belt or feed table and then side tipping it by means of a hoist, thus depositing the cane to the required place.
- .07 Lorries from outgrowers farms are either tipper or are unloaded by grabbers.

3.00 Weighing...

Weigh
house

Weigh
bridge

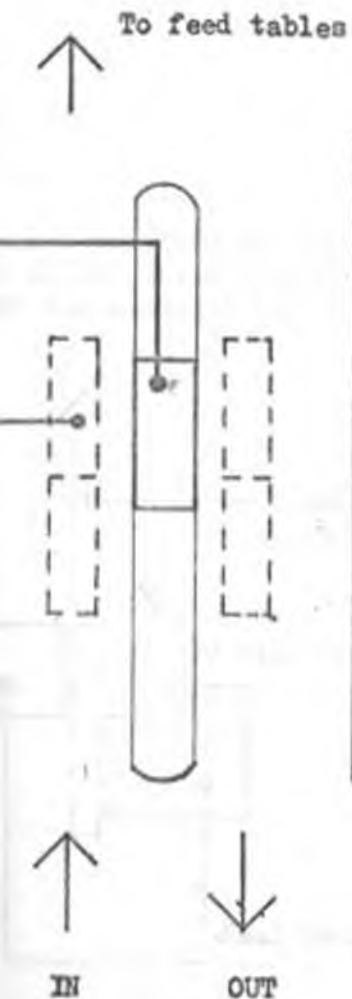

.01 On arrival at the factory site the loaded lorries and trailers are weighed as they enter and then re-weighed as they leave the factory.

.02 The difference of the two weights gives the weight of the cane.

.03 The weighing is done on weigh bridges fitted flush with the road floor level.

.04 Readings are recorded from a scale inside a weigh-house.

Weighing contd. _____

.05 On weighing, the loaded trailers are then pulled to the tipping platform for unloading onto the feed tables.

.06 If the factory is not working (say at night or on a cleaning day) the trailers then empty at a storage area from which the cane can be loaded onto the feed tables when the factory commences work.

.07 The location of this storage zone is such that a front grabber can load the cane onto the feed tables without much travelling.

Pneumatic hoist

(side tips loaded trailers to empty cane on feed tables which transfer the cane onto the conveyor belt)

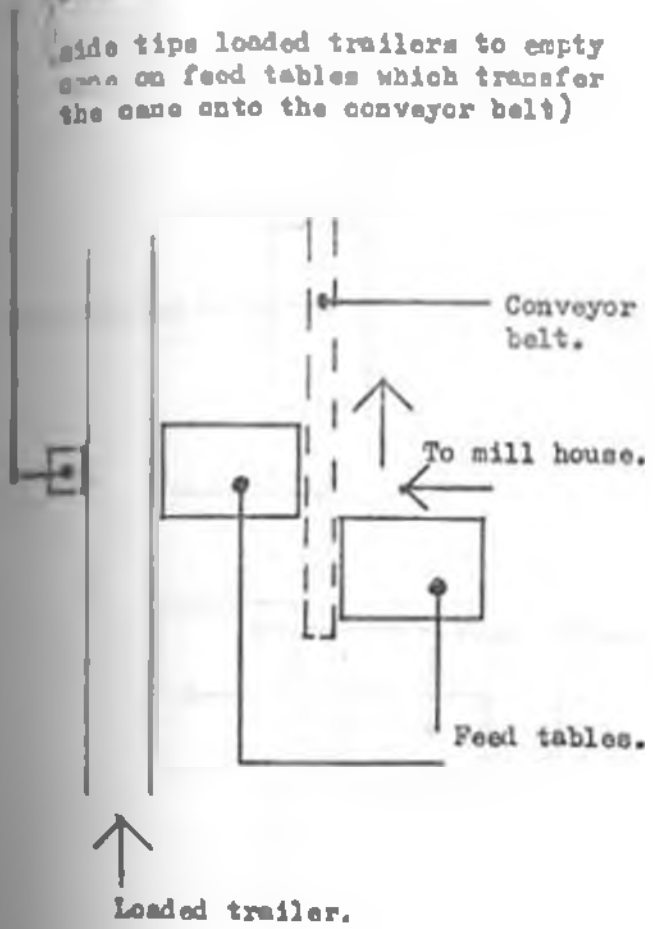

100 MILLING



CASE KNIVING

CONVEYOR
BELT.



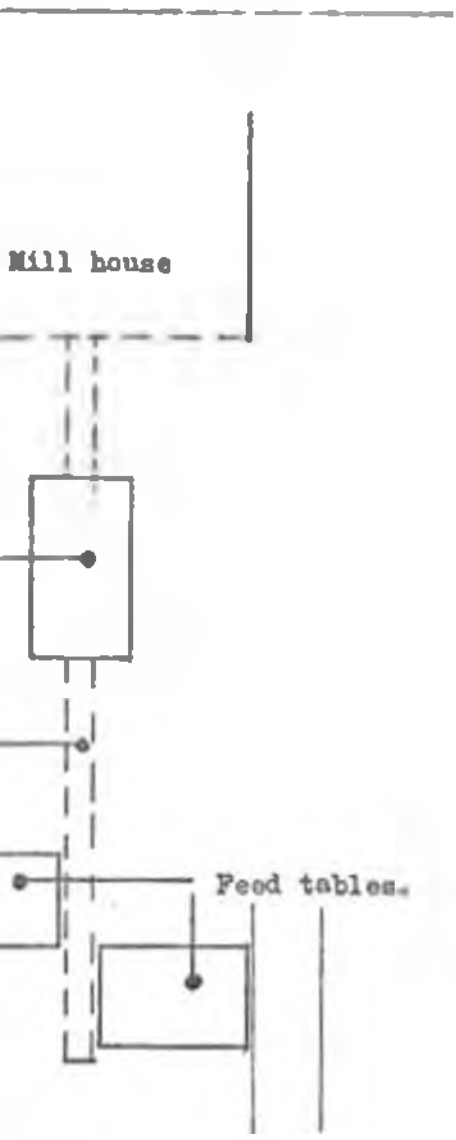

.01 The conveyor belt which transfers the raw cane from the feed tables to the mills passes through a sub station whereby revolving knives cut the cane into very small pieces.

.02 This process is intended to open up the cane fibres so that juice can be squeezed out easily.

.03 The cut cane pieces are then fed into rollers which squeeze the juice out. This is the milling station and involves five to six sets of mills - for effective squeezing.

5.00 Liming

.01 The juice leaving the mills is very dirty due to suspended fibres and mud.

.02 It has to be rendered clean before it can be processed further.

.03 The cleaning process involves adding chemicals (lime and sulphur) to help precipitate the suspended materials.

.04 At this state the juice is also weighed, to enable the factory to assess its juice extraction efficiency.

.05 Thus the juice coming from the mills is pumped to an automatic weighing container which in turn passes the juice to another container where the juice is mixed with lime.

.06 The limed juice is heated (to speed up the precipitation) and then pumped to the sulphur towers where addition of sulphur helps to finalise the precipitation.

6.00 Clarifying/filtering

.01 Juice from the sulphur towers is led to a big drum (the clarifier) which by a rotating process separates the juice and the suspended muds.

.02 But the muds referred to above have some percentage of juice in them.

.03 This is further removed by mixing the mud with the fine cane fibre from the mills and then squeezing it out in a filter system that leaves the mud in a cake form.

7.00

Evaporation

.01 Before clarified juice is ready for crystallization into sugar it is concentrated into a syrupy consistency through a multiple effect system of evaporators arranged in series.

.02 Evaporator series are normally four or five if factory expansion is envisaged one big evaporator can be installed to work in conjunction with either series.

.03 Vapor from the evaporators is disposed in a lake or pool.

8.00 Pans

(Boiling of raw sugar massécuits)

.01 Clarified juice evaporated in multiple effect evaporators to a syrupy consistency must be further evaporated in order that raw sugar will crystallize from it.

.02 This is done in vacuum pans, vessels in which the syrup is boiled under vacuum to form a heavy mixture of crystals and mother liquor called MASSECUITÉ.

.03 Vacuum pans are single effect evaporators of a diameter of approximately 4 m. (14').

1.0 crystallization

.01 There are three zones above the saturation point of cane juice namely:-

: Metastable zone - where existing crystals grow and no new ones are formed.

: Intermediate zone - where new crystals are formed in the presence of existing crystals.

: Liable zone - highest of all.

Here crystals are formed spontaneously without the presence of others.

.02 Thus at the end of boiling the low grade massecuite is discharged from the vacuum pans into the crystallizers for cooling.

.03 The purpose of cooling in the crystallizer is to maintain the supersaturation of the mother liquor at the 'metastable zone' throughout the cooling process. This avoids the formation of false grains.

9.00

cryst

.04 The crystallizers should be placed under the vacuum pans and above the centrifugals and sufficient drop should be provided to assure quick discharge of messecuite from pans to crystallizers and then to centrifugals.

.05 The above arrangements avoids pumping which is inefficient at this stage. Thus one has to utilize gravity.

10.00 Centrifuging

.01 For separation of hard and liquid phases of raw sugar centrifugals are used.

.02 Though large centrifugals can be built the centrifuging station is less flexible with large centrifugals. Smaller ones are therefore used.

.03 The liquid phase which cannot be converted into raw sugar (referred to as MOLASSES) is pumped out and stored in the molasses storage tanks.

11.00 Bagging —

.01 Raw sugar from the centrifugals goes through a conveyor belt and drier combination and is transported to storage bins.

.02 The conveyor belt should be of the vibrating type to ensure that crystals do not stick on each other.

.03 The storage bins have rot exits at which bags are attached during bagging. The operation is gravity controlled.

.04 At the bagging station the sugar bags (full) are weighed.

17,00

Storage

—

.01 Bags full of sugar are conveyed from the last manufacturing station to a storage area.

.02 The store should be moisture-proof in order not to damage the sugar (discussed further in ch. five).

.03 But the module of the store should be a bag of sugar with possible alternative arrangements.

.04 Design of store should also consider loading onto transportation vehicles when the sugar is being distributed to various suppliers.

CHAPTER FOUR

PLANT LAYOUT

Factory design is governed by plant layout as dictated by the manufacturing process. This chapter on plant (Machinery & Equipment) layout is discussed under the headings:-

- 1.00 General objectives
- 2.00 Requirements for machinery
- 3.00 Weight
- 4.00 Process requirements
- 5.00 Requirements for material
- 6.00 Movement
- 7.00 The factor man
- 8.00 Psychological or personal considerations
- 9.00 Organisation & supervision
- 10.00 Services
- 11.00 Offices (Administration)

1.00 General objectives.

.01 Plant layout is an industrial fundamental as it greatly determines the efficiency and in some instances the survival of an enterprise.

.02 It embraces the physical arrangement of industrial facilities.

.03 This arrangement whether installed or in plan includes the spaces needed for material movement, storage, indirect labor and all other supporting activities or services as well as for operating equipment and personnel.

.04 Due to the specialization of labor (operation) the handling of materials between operations should be given major attention.

.05 The objective is to have an arrangement of work areas & equipment that will be the most economical to operate and yet safe and satisfying for employees.

.06 Thus management + (men + materials + machinery) = production. This formula should be headed.

.07 A good layout takes into consideration the state of existence of the material to take advantage of dumping, moving by conveyor belt, gliding or flowing by gravity.

.08 The above factor is very important in the design of a sugar factory where the state of the raw material changes from raw cane to juice then to a syrupy consistency and lastly to sugar crystals.

.09 Movement of men, material & machinery can be in any of the three directions (cubic space).

.10 A good plant layout decides which of the three factors of production should move or their relative movement. (i.e. men, material & machinery).

.11 Thus the successful layout results in better control of costs, easier maintenance of equipment, and ability to keep factory clean.

.12 The end result is an integration of all the facilities into one big operation unit. In a sense

1.00 General objectives contd. _____

it is the making of a single operating machine out of the plant.

2.00 Requirement

.01 Plant layout work is basically arranging certain specific amounts of space with relation to each other to give us their optimum functioning.

.02 Long and narrow machines, short and compact ones, or circular or rectangular - each shape dictates the machine arrangement in relation to other machines and to other features and considerations.

.03 For every machine one needs some dimensions - length & width as a minimum.

.04 Parts of machines that swing or overhand should be noted.

NR Machine dimensions (& also those of other equipment) & their space requirements are given in the chapter dealing with the building brief.

.05 Also necessary is the height of operating equipment which should include any extensions, superstructures and feed hoppers etc. - thus enabling one to determine the height of ceilings, roof

2.00 Requirement

for machinery contd.

or overhead installations.

.06 For instance where the use of gravity is involved (e.g. in the crystallization station of sugar) particular attention must be given to height of equipment or its various parts.

1-20 Weight

.01 Some processes require very strong floors.

.02 These dictate a basement or ground floor location.

.03 Almost every kind of large, heavy machinery and equipment falls in this category.

.04 The juice extraction tandem (mills & turbines) and the boilers are typical examples of manufacturing stations of sugar requiring strong floors.

4.00 Process requirements

.01 Some processes emit fumes and smoke.

.02 Exhausts from such should be carefully placed so that their contents do not go back to the factory where they might produce uncomfortable conditions as well as corrosion.

Requirements for material _____

.01 When material waits in a regular area set aside for holding waiting material such a situation is referred to as 'STORAGE'.

.02 But when material waits in the production area when not immediately moved to the next operation the situation is referred to as 'DELAY'.

.03 The two must be provided for in the design.

.04 Typical waiting situation include:-

: Receiving or incoming material area.

: Raw or purchased material storage.

: In process storage

: Delays between operations

: Finished or outgoing material storage

: Storage areas for supplies, package materials,

maintenance spare parts, drawings and samples.

.05 All of the above mentioned are very critical in a sugar factory.

.06 Storage for tools, fixtures, standby or inactive machinery and equipment intermittently used or

Requirements for material contd.

extra handling equipment are other areas under the waiting factor.

.07 Several considerations affect a layout as far as waiting is concerned - namely:-

- : the location of storage or dealy points.
- : centralization or decontration
- : method of storing
- : space for each area and the time the material should stay there.

.08 The method of holding waiting material affects the space and location.

.09 Possibilities which help conserve space include:-

- : use of cubic space and not merely spreading over floor area.

- : It is possible to use stacking, holding on balconies, overhead carriers etc.

- : Use of outside storage space - probably protected.

6.00 Requirements for material contd.

: making dimensions of storage areas as a multiple of item dimensions .

: positioning long dimensions of materials, shelving etc. perpendicular to main service aisles.

.10 Very important also is to safeguard waiting material from:

: fire

: damage - falling or rolling

: Moisture, rust & corrosion

: dust and dirt

: even pilferage - provide strong rooms.

6.00 Movement _____

.01 Movement of at least one of the basic elements of production - materials, men or machinery - is essential.

.02 Usually it is the material - raw in process or finished products which move.

.03 It is essential to plan so that material moves as little as is consistent with other production factors.

.04 Thus one should plan a plant layout that ensures short moves but moves that are always toward completion of the product; then set up operating controls to keep it moving.

.05 Relevant physical features of the movement - hence handling - factor in a sugar industry include:

- : transportation vehicles
- : cranes and other lifters
- : conveyors - roller, wheel, belt etc.
- : chutes, tubes, pipes, guide rails.

5.00 Movement contd. _

: elevators, lifts, hoists, winches.

: water carriers, - canals, pipes, flumes.

.06 It is essential to establish a flow pattern through processes or a routing where every material move is essential.

.07 Done properly it automatically reduces the amount of handling and it means the material will progress with each move towards completion of the manufacturing process.

.08 For instance in the sugar industry the direct unloading of raw cane from the transportation vehicles to the factory conveyor belt reduces handling of cane at the factory yard.

.09 Otherwise unloading cane onto a storage yard and then using grabbers to load it onto the conveyor belt results in too much handling.

.10 Incoming material - whatever the means of receiving it - should have convenient access to the factory (plant).

5.00 Movement contd.



- .11 This is where flow of material starts and is therefore a key point in layout.
- .12 Its location should be therefore carefully planned.
- .13 The outgoing point is the end of material flow for the plant layout. It stands between the producing facilities and the outside world.
- .14 Therefore means of exporting should be as close to the last operations or finished storage as is feasible.
- .15 In the factory the movement of services or supply materials to the production areas is part of the industrial operation.
- .16 Similarly the removal of wastes e.g. ashes, muds, etc. are as important as the storage of the finished sugar.
- .17 Also important is the movement of machinery. For instance heavy machinery requires the installation of overhead cranes. This should be planned

12. Movement contd.



for.

.18 Integration of this factor with the various areas requiring machinery movement is vital for greater savings.

.19 Possibilities of integrating support for such cranes with the building structure should be exploited to the fullest.

.20 In a sugar factory the manufacturing stations which might require the installation of overhead cranes include the mill house, the main factory station, the power house and the factory work shop.

.21 Layout should provide enough aisle space for men movement.

.22 It should ensure that long conveyors do not make people go all the way round to get to the other side. This is tiring and time consuming.

.23 Nor should it tempt workers to vault over dangerous moving belts.



DANGEROUS



SAFE

5.00 Movement contd.

.24 Jumbled or crowded equipment makes it difficult for inspectors to have access for control of operations.

7.00 The factor man_

-
- .01 Here I am trying to emphasize on safety and safety and working conditions.
- .02 The factory floor should be free from obstruction and not slippery.
- .03 Workers should not be located too near moving parts, unguarded equipment, and any other hazards.
- .04 Workers should not be located under or above hazards nor should design rely too much on workers having to use safety devices or guards.
- .05 There should be adequate exits and clear enclosures.
- .06 First aid facilities and fire extinguishers should be located nearby.
- .07 No sharp moving or hazardous material or equipment should protrude into aisles or work areas.
- .08 The layout should in total satisfy all safety codes and regulations.
- .09 Less noise, vibration and good ventilation add to workers comfort.



.01 Fear of potential injury causes workers to be
timid.

.02 For instance transport operations moving
around workers scare them - piled stuff might fall
on them.

.03 Many people like to have a little room around
them.

.04 They do not like being placed next to each
other or to equipment or walls - especially if they
come from the "GREAT OPEN SPACES".

.05 At the same time workers do not like to work
alone.

.06 Two or three men assigned to lone operations
on the third shift while the rest of the plant is
quiet will eventually end up bringing their work
areas together or abandoning it and spending half
the time drinking coffee in the boiler room or even
quitting.

Psychological or personal
considerations contd. _____

.07 Women will not want to work on platforms
built up from the floor.

.08 They will also feel uncomfortable if their
work places face directions like men's changing
rooms.

.01 The best layout is useless if it does not fit the organization of the company.

.02 Actually a management organization chart itself often establishes what the overall layout plan should be like.

.03 When undertaking a layout it is therefore important to examine the company's organization chart.

.04 Such a diagram is given in the next page.

.05 Layout or structuring of departments should be such that it does not make one foreman feel that he supervises less area than another foreman of equal rank.

.06 Office location should take into consideration the viability of the area to be supervised.

.07 As a formula the biggest point about man and layout should be for all persons to feel they are part of it.

FACTORY MANAGER



.OR The success of a layout often depends as much on how well it is accepted as on how efficient it is.

10.00 Services_____

.01 Services relating to men can be summarized as:-

: access ways

: employee facilities e.g. toilets, showers, canteen.

: Fire protection - to comply with local authority regulations.

: lighting, cooling & ventilation.

.02 A good layout should take into account that the sequence of operations of a worker must be in his way of travel.

.03 The entry way, the parking lot & public transportation stops are man's starting points.

.04 And the work place is the end point.

.05 Between the above two mentioned points are or should be the passageways, locker rooms and wash-rooms etc.

.06 All these facilities should be planned in the right sequence.

111.00

Services contd.

.07 They can be under or above the production floor but should be easily accessible from workers' floors.

.08 Services relating to materials involve functions like:

: quality control - sampling, & laboratory tests - should be conducted in spaces providing adequate facilities for such scientific exercises.

: production control - involving co-ordination of all departments.

: waste control - a method of assessing or quantifying the amount of waste helps the management to establish its production efficiency.

.09 Services relating to machinery include providing room for emergency maintenance.

.10 One should not only plan for idle day maintenance.

.11 Room or spaces should be provided for the distribution of auxiliary services lines such as

10.00 Services contd

steam pipes for boilers, raw juice pipes, & power
lines.

.12 Stations using power from one source should
if possible be grouped together.

11.00 Offices (Administration) _____

.01 Amount of office space and location depend on organisation.

.02 But if possible it is best to separate general administration offices from shop offices (in a factory as big as a sugar one) so as to allow related office functions to be placed closer together.

.03 This also keeps general administrators away from factory noise.

.04 An example of good office planning is the placing of the purchasing officer near the reception office but still near the production planning officer and accounting department.

.05 Or placing the personnel near the main gate or backing up to factory.

.06 Such location requirements should be compromised in the attempt to come out with an economical yet efficient office plan.

LOCATION OF THE SUGAR FACTORY.

CHAPTER FIVE

LOCATION OF THE SUGAR FACTORY

The location of the sugar factory is analysed under several headings namely:-

- 1.00 Sugar cane growing areas and the Agricultural Policy.
- 2.00 Proximity to raw materials.
- 3.00 Availability of power.
- 4.00 Transportation arteries.
- 5.00 Government Policy (zoning & pollution control)
- 6.00 Planning of plantation.
- 7.00 Labor and training.

.01 In Kenya (as in many other parts of the world) sugar cane is grown in the fairly wet areas of the country.

.02 The coastal region and extensive areas in the lake region - Nyanza and Western Provinces - have some of the best sugar cane growing climates in Kenya.

.03 In some of these regions irrigation schemes are carried out but in others there is enough rain to support the crop.

.04 It is worth noting that the residents of these regions have been growing and still grow sugarcane (in small scale farms.) as a cash crop which they sell to local factory (sukari quru) manufacturing industries within their region.

.05 But due to increased demand for sugar the Ministry of Agriculture has been encouraging expansion of farms (even formation of co-ops.) and the use of better hybrids of cane in an attempt to build

up production in order to establish sugar processing factories.

.06 But these small scale farms plus any co-operative ones formed cannot reliably produce enough cane to keep a factory running profitably throughout the year.

.07 So the usual Government practice is that when a region proves to be suitable for cane growing the Government commissions an Agricultural Company to organise a big cane plantation in the selected area.

.08 The commissioned company normally leases the land from the Government and any people living in it are resettled elsewhere.

.09 The company then starts cane growing and also making plans for the erection of the processing factory.

2.00 Proximity to raw materials _____

.01 A factory should be near to raw materials especially where the raw material is bulky and of low value.

.02 Living examples include:-

: Location of furnaces near either coal fields or iron ore deposits.

: Cement works being alongside chalk hills.

: Breweries near to supplies of suitable water.

.03 Thus each of the above cases ensures that the bulkiest raw material has not far to travel.

.04 The location of a sugar factory should also be decided with the above point in mind.

.05 Raw cane and water are the two commodities used in great quantities in a sugar factory.

2.00 Proximity to raw materials contd.

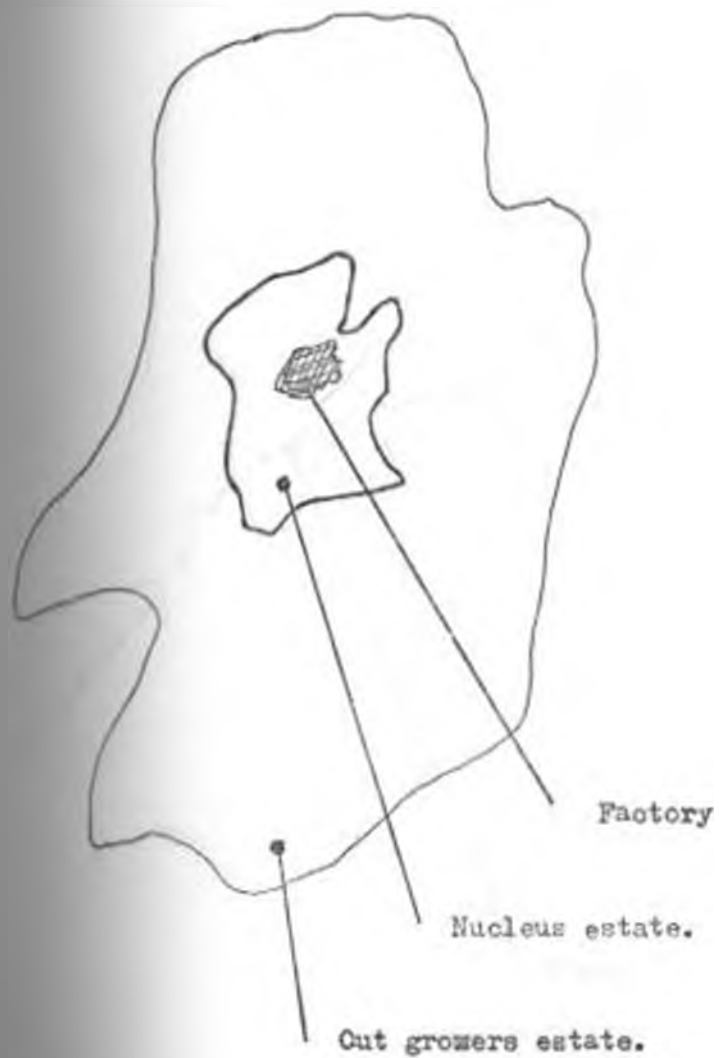

.06 The factory should therefore be located centrally in relation to the total sugar growing estate

.07 The best way is to have the large company owned plantation (hereafter referred to as the "nucleus estate") located fairly centrally in relation to the whole sugar growing region, and then have the processing factory located in this nucleus estate.

Availability of power



.01 Here in Kenya the Government and the East African Power and Lighting Company have it their policy to make available electricity to as many of this country as is possible.

.02 But though electricity has its particular uses in a sugar factory e.g. lighting, driving motors etc. it is not the main source of power in a sugar factory.

.03 Steam turbines drive most of the machinery as well as performing other heating duties.

.04 So in locating a sugar factory investigation regarding availability of reliable supplies of water is important.

.05 Sugar cane growing areas are some of the wettest parts of Kenya and therefore it is not difficult to find suitable factory location near a river.

606 Transportation arteries -----



Regional highway.

.01 When a factory is situated adjacent to a railway or main road this saves the company extra expenses in constructing transportation routes.

.02 Another hidden advantage is that such a visible location is a cheap way of keeping the company's name before the public.

.03 Therefore in locating both the nucleus estate and the factory proper it is necessary to take into consideration the existing regional highways to enable locating the factory in the most accessible site possible.

5.00 Government Policy_____

(zoning & pollution control.)

.01 Concerned Governments have passed acts governing the location of their industries.

.02 This is an attempt to keep out factories from areas which are earmarked for other developments e.g. recreation, housing etc.

.03 Of major concern today is the increase in atmospheric pollution due to industrial wastes.

.04 Our Government has as such no legal pollution control standards but none the less it has expressed concern.

.05 Now as concerns the location of a sugar factory we have already seen that it best fits within the plantation.

5.00 Govt. Policy contd. _____

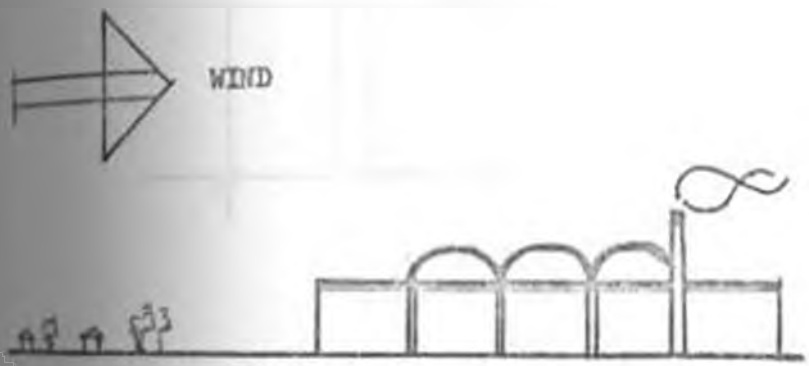
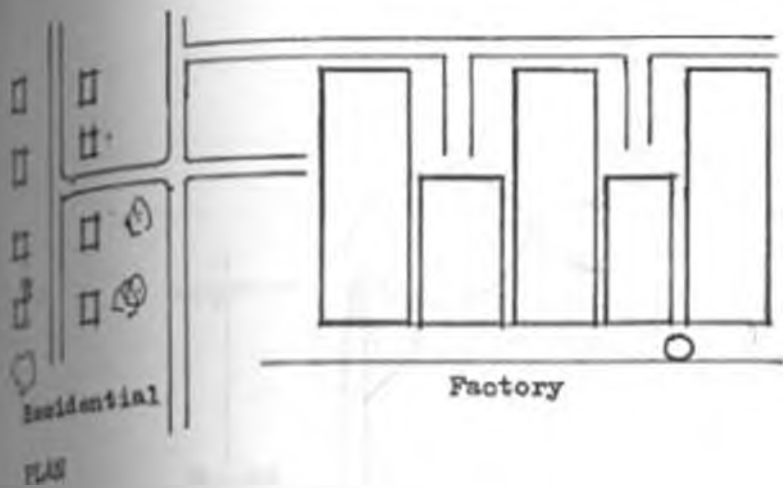

333333

.06 In such a location the two most serious pollution problems are:-

- : Smoke from the boilers
- : Dirty water & other effluents.

.07 Pollution properties of smoke are well known to most people. The most popular thing is that it dilutes the air we breathe making it even impalatable.

.08 It is therefore important to consider wind direction when laying out a factory estate (manufacturing buildings & welfare facilities) so that smoke does not blow in the direction of the residential quarters.

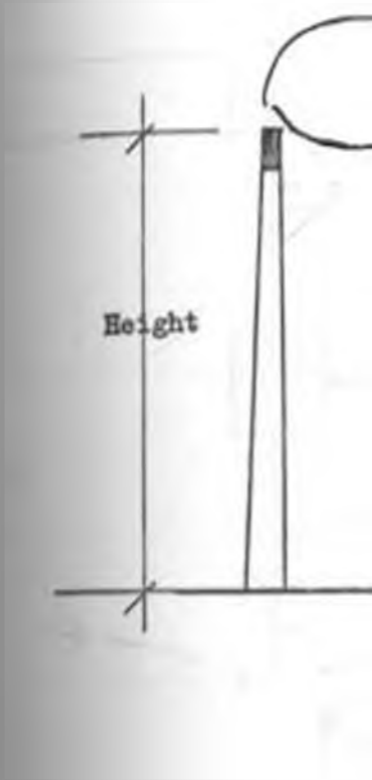

.09 Heights of smoke flues should be such that smoke comes out at heights that allow it to be blown away from the factory estate where most people are.

.10 Now as concerns dirty water (especially that from a sugar factory) no one has as yet said what pollution effects it could have to rivers if drained into them.

.11 But during my visit to these sugar cane growing areas I observed that the residents of these areas use the rivers for washing their clothes as well as their bodies.

.12 So polluting these rivers with dirty factory water is tantamount to robbing these people of their only bath tub.

100 Govt. Policy contd.

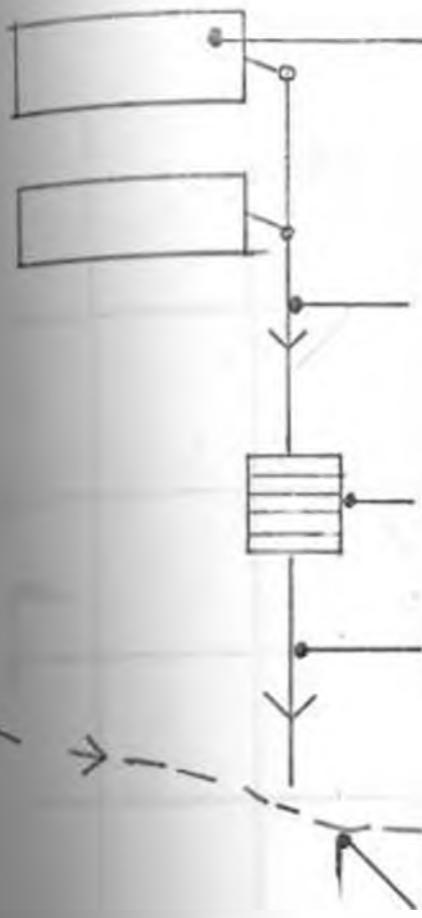

.13 The dirty water from the factory should therefore be cleaned before it is allowed to flow back to the river.

Factory

.14 This is afforded by draining this water to settlement pits where all dirt is filtered and probably chemicals added to remove all other impurities.

Dirty water

.15 I feel that there is need for Government legislation to establish an investigation to assess what actual pollution properties such dirty water has.

Settlement
pits

Clean water

River

4.01 Planning of the plantation
(Master plan of the nucleus estate)

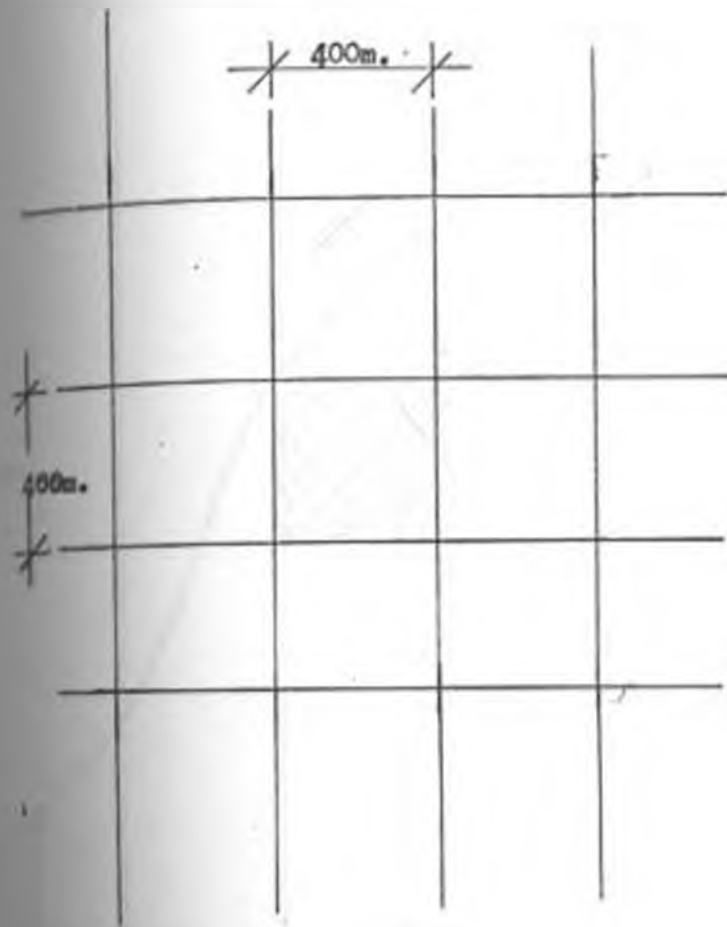

.01 A sugarcane plantation should be planned in such a way that it is easily accessible during planting, cultivation, harvesting and transportation of the cane to the factory.

.02 The common practice is to segment the total plantation into small plots of approximately 400 metres square each.

.03 Such a segmentation enables the creation of access ways all around each plot.

.04 The access ways, together with being used for movement do also serve as fire boundaries.

1.00 Planning of the plantation contd.

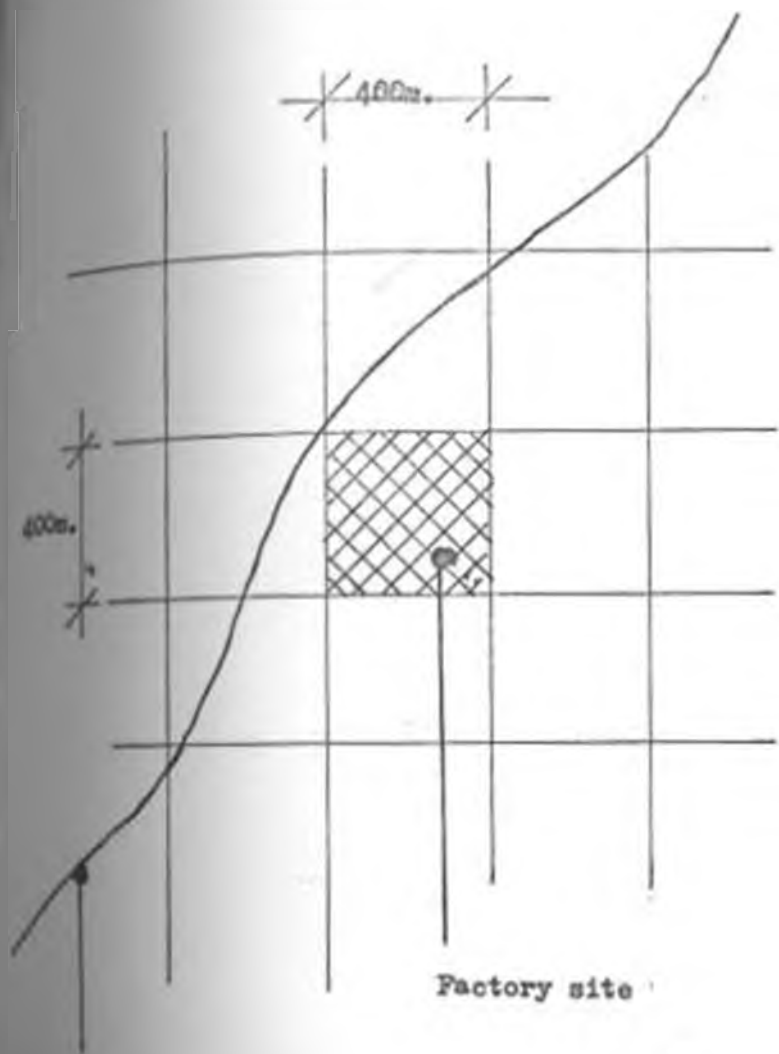

Factory site

Regional road,

.05 Such a sub-division makes it easy for the farm management especially when phasing their planting seasons and also when allocating their workers to the different work areas.

.06 It is also in one or more of these plots that both the factory buildings and the labor welfare facilities are located.

7.00 Labor & Training

.01 There are more than enough breathing bodies to be recruited to work both in the nucleus estate plantation as well as in the factory itself.

.02 But the location of the factory and its 24 hour work programme will require the workers to live at or near the work place.

.03 Alternatively workers can be transported from their homes to their work places. - a fairly expensive & complicated operation since people's homes are scattered all over the region.

.04 Anyway there is an additional chapter talking about housing and other welfare facilities.

.05 But at this stage I would like to point out that although people are available for the jobs, they need training to be able to perform the complicated operations - say in the factory.

.06 The existing sugar factories have been recruiting completely lay people and let them learn the job.

7.00 Labor & Training contd. _____

.07 But it is necessary to establish a training program (or division) to cover all aspects of work & not just the particular operation one learns in this "on the job experience".

.08 Most of the existing factories realized this and are talking about possibilities of establishing a joint training venture - it is actually of no sense for each factory to operate its own training school.

.09 Training as I tried to point out earlier should not be geared only at imparting knowledge & skills that make possible increases in output.

.10 The training should also aim at inculcating certain attitudes in work that can directly raise productivity and efficiency in labor utilization.

.11 In my visit to one of the sugar factories I saw a worker who though fully aware of what operation he was supposed to perform next did not do so until he was shouted at by the supervisor.

Training contd. _____

.12 I mean this is the kind of attitude we can ill afford - especially at this stage in African development.

.13 A-1 in sugar growing areas are characterized by people who go to look for a job when they need cash & immediately they think they have enough they quit job and go home.

.14 Thus one needs a continuous training programme to facilitate replacement.

.15 The Supervisory and other high calibre technical staff are at present very expatriate.

.16 None the less there is an attempt to Africanise.

.17 This is being done by recruiting engineers from the University & Technicians from the Polytechnic.

.18 But all these need orientation on sugar manufacturing & plant operation & maintenance.

.19 Such an orientation is what such a training facility could cater for.

OVERHAUL LAKEIT ON THE SUGAR FACTORY

CHAPTER SIX

Overall layout of the factory site

.01 The layout of any industrial unit whether large or small must be prepared with two main considerations:-

: The ease and efficiency with which the unit can be run.

: The relationship of the unit to its neighbours whether town or country.

.02 The main layout of the operation areas or sections must be planned in relation to the means of access to the site and also in relation to the roads by which raw materials and finished materials are delivered and dispatched.

.03 These areas should be so arranged that cross traffic is avoided as much as possible and that the distance between transport services and the buildings concerned is reduced to a minimum.

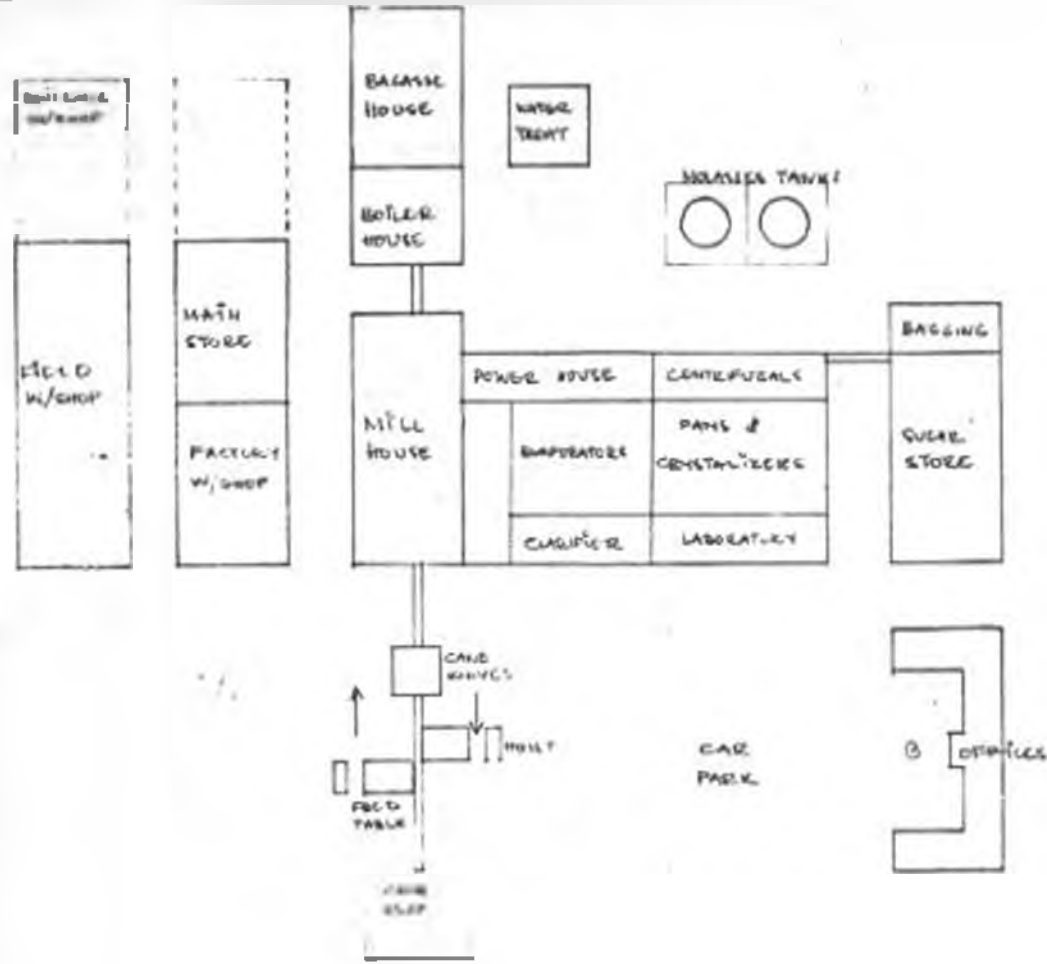

ALTERNATIVE PROPOSAL - MUMIAS SUGAR FACTORY 1:500

← *initials*

FROM CHEMILIL
TOWNSHIP

STATION



STATION

AGRI SA

FACTORY SITE

← LAPEY

RA FEL

AREA 2000

LABOR CAMP

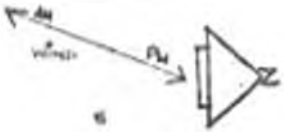

To make
water

FACTORY ESTATE - CHEMILIL SUGAR FACTORY SCALE 1:2 000

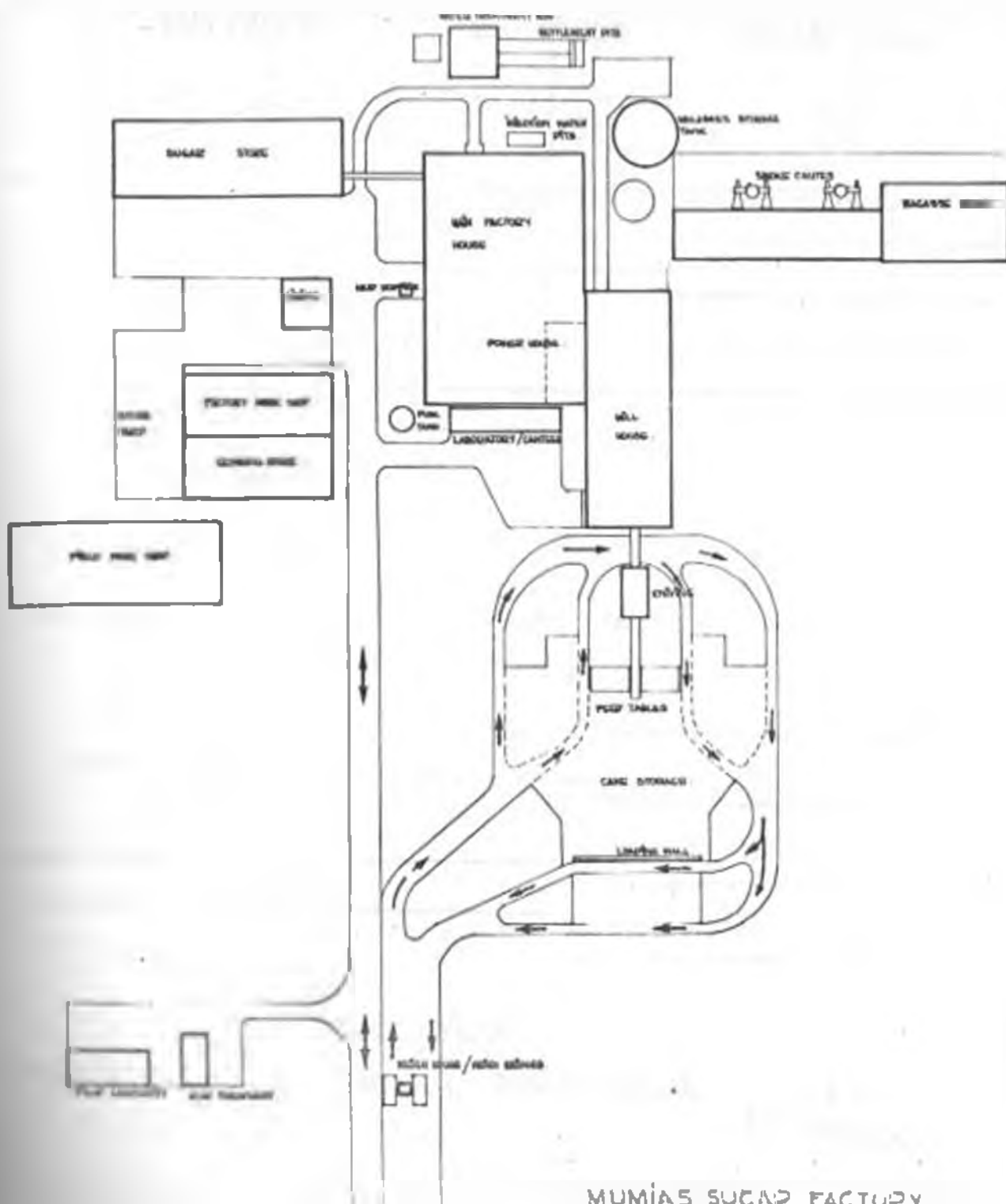

MUMIAS SUGAR FACTORY

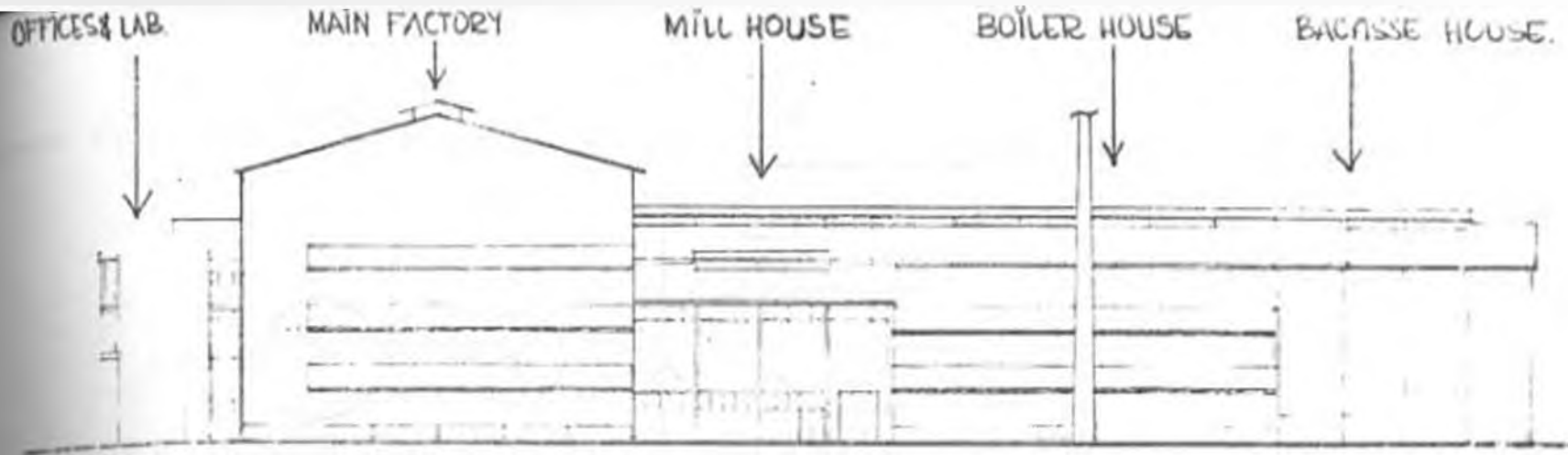

SOUTH VIEW

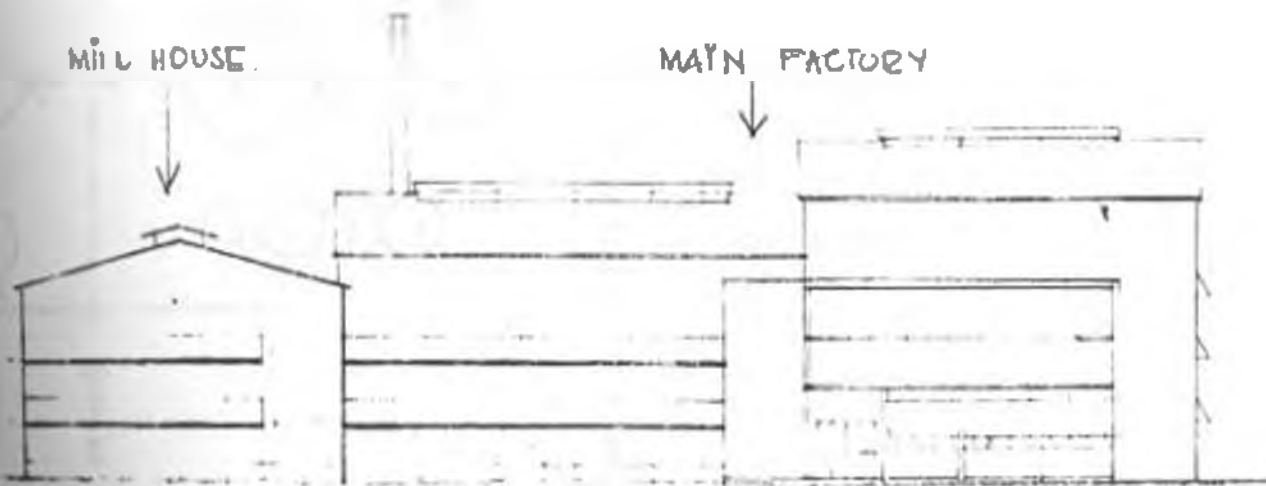

WEST VIEW

SAMPLE ELEVATIONS - CHEMILL SUGAR MILLS 1:200

← H. Stone

Functional Diagram

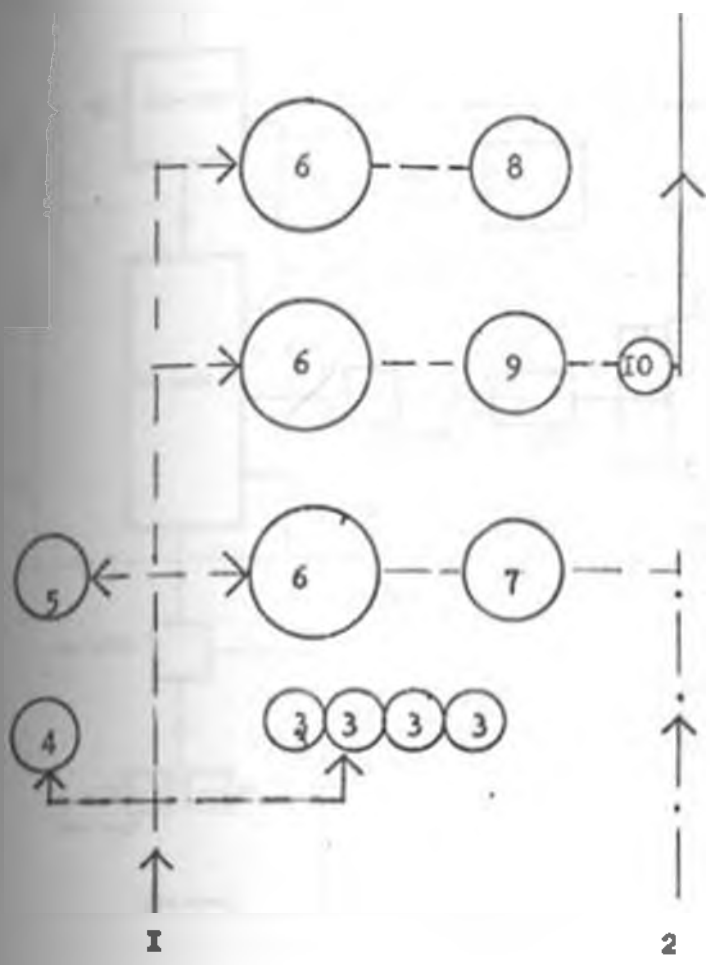

- Key:
- Personnel circulation
 - ==|---|---|---|--- Materials
 - Finished products.

- (1) Personnel entry
- (2) Goods entry
- (3) Office Administration
- (4) Gate house
- (5) Welfare
- (6) Manufacturing
- (7) Raw materials store
- (8) Goods store
- (9) Packing
- (10) Loading

1.00 Factory layout contl. _____

.04 A layout should take into consideration the relationships between different functional spaces so that related spaces are placed in relation to each other either in plan or section.

.05 In my case studies of existing sugar factories I established several distinct function space categories.

.06 The list includes:-

:THE MILL - where the actual sugar processing takes place.

:STORAGE SPACE - which includes storage for raw materials (cane) and also for the finished sugar

:THE LABORATORY - where control & testing of incoming, intermediate and finished products is carried out.

:OFFICE SPACE - where executive, and administrative headquarters of the firm (including sales, accounts, purchasing) and other sections of the firm's business operations.

MAINTENANCE & TRANSPORT - for the construction and repair of plant, & machinery; the maintenance of the factory buildings; the accommodation and maintenance of transport vehicles.

SERVICE SPACES - catering for the supply of services needed for the operation of the factory plant & machinery (such services are electricity, water, boilers, ~~etc.~~ plant etc.)

WELFARE FACILITY SPACES - for the maintenance of the well-being of the working people employed in the factory - e.g. canteen, staff room, dispensary & first aid.

HR Housing and other leisure welfare facilities are discussed in a later chapter.

.07 Each of the above space categories will be discussed later in more detail under heading 2.00 - the factory buildings.

.08 But their inter-relationship in an overall layout also in relation to movement lines and

servicing in general and also in relation to the manufacturing process is what follows below.

.09 To begin with in considering the location of any of the above function areas in a sugar factory site also the question of movement lines or transportation must be examined and the necessary allowances made.

.10 First, the transportation of raw cane to the processing stations should be analysed.

.11 This applies both to the directly arriving cane and to the cane for the storage yard - if any.



.12 The sketches attached describe how the raw material transportation is related to the mill house - where sugar processing begins.

.13 At the exit end I described methods of providing loading bays where ready stock in bags is loaded onto lorries.

.14 I have limited myself to loading bays for lorries only because this is the most popular (or usual) method of transporting sugar from the factories to the distribution centres.

.15 The exercise is therefore that of creating adequate road for lorries to enter, park, get loaded and move away.

.16 The (trucks) movement of the material in process has been already described in the chapter dealing with the manufacturing process.

100 Factory layout contl. _____

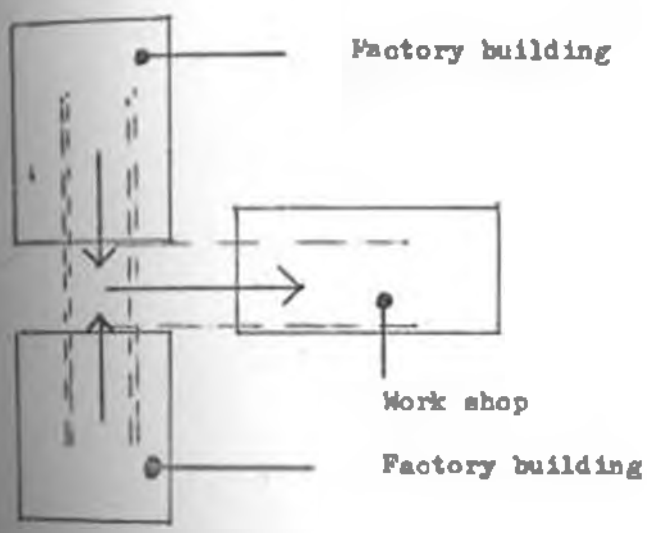
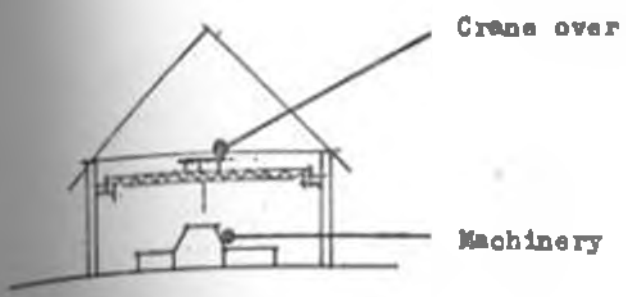

11. Arrows indicate movement of cranes from factory to work shop.

.17 But another factor to note is that a sugar factory is characterized by heavy machinery and equipment which require to be moved mechanically both within the manufacturing space to the factory workshop for mending.

.18 Equipment movement paths should be allowed for during the plan period and the location of the workshop in relation to the factory buildings also analysed.

.19 Workshops with the heaviest equipment and machinery are the mill house, the main factory building, and the power house.

6.00

Factory layout contd.

.20 The disposal of waste products from a factory is as important as the dispatch of the finished products.

.21 Therefore access for the removal of ash discharged from the boilers and also for the removal of molasses (the final waste product of sugar) should be planned.

.22 While talking about this aspect of movement or transport in a sugar factory I would like to touch on the design of the road surfaces.

.23 These are to be designed to have sufficient camber to allow for surface water to drain away quickly to keep the roads clean.

.24 Maximum sizes for commercial vehicles are used (from design guides) - as the overall sizes do affect the dimensions of loading bays, turning spaces, carages and road curves.

.25 Two most popular construction materials for

factory layout contd



factory roads are reinforced concrete and tar-macadam.

.26 Tar-macadam roads need frequent maintainance with heavy traffic and are badly affected by any solvents or acids which are bound to be accidentally spilt at some time.

.27 Thus concrete reinforced with wire mesh is to be preferred with adequate expansion joints provided to prevent crashing.

.28 The effect of service supplies on a layout cannot be over-emphasized.

.29 For instance water is used in vast quantities in a sugar factory - for both general use e.g. washing floors and for process plants - as steam.

1.30 Factory layout contd. _____

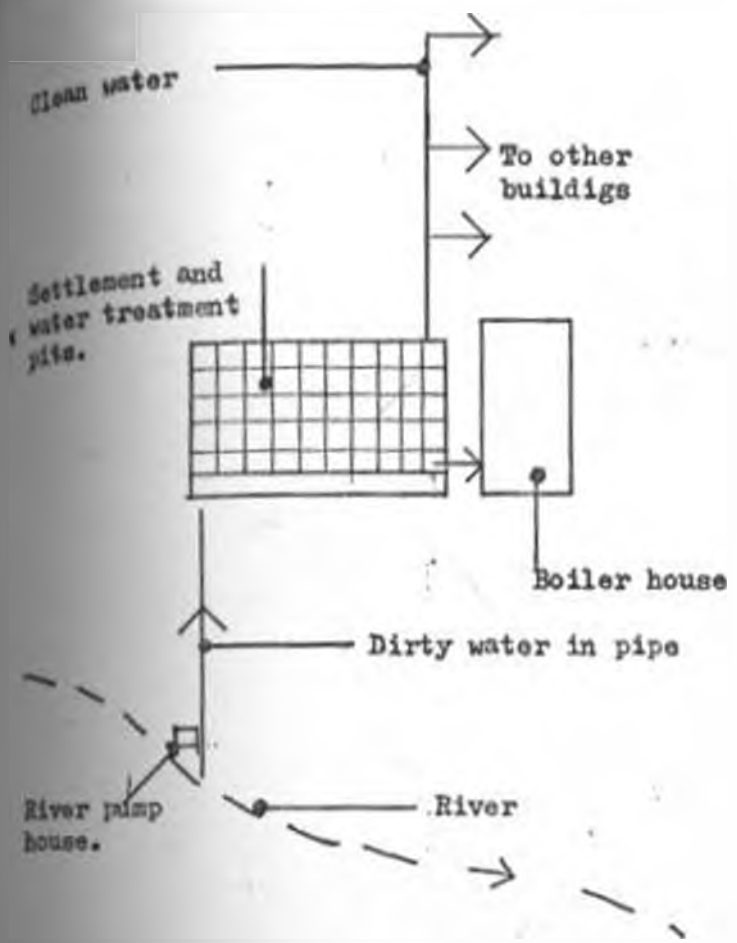

.30 Such quantities are normally obtained from a river.

.31 Since river water is usually dirty, settlement pits and a water treatment house have to be provided at the factory site.

.32 These settlement pits should be located near the factory boiler house where the bulk of the water is consumed though this should water also be available to other parts of the factory.

.33 Such settlement pits if well designed and with good gardenin; around can offer a rood scenery from an office block or the canteen.

.34 Similarly in this sugar factory where a lot of steam is required for both process plant and other heating purposes steam boilers have to be located rather centrally so that undully long pipes are avoided.

1107 (Factory layout contd. _____

.35 Talking about steam and water leads on to another important aspect of layout - and that is drainage.

.36 Four categories of drainage are to be considered in the planning stage.

.37 First is land drainage to carry natural surface water away.

.38 Next in the line is surface (Rainwater) drains for taking clean water from roofs, roads etc. to surface water sewer. These drains should preferably be laid in stoneware pipes laid in cement mortar on concrete bed and should be surrounded by concrete if running under a building.

.39 Third in the list is soil drains to take waste from lavatory basins, sinks, w.c's and other domestic sewerage (e.g. canteen waste) to soil sewer. These are to be of tested stone ware and laid as for surface water pipes.

100

factory layout contd.

.40 Lastly is the trade affluent waste from process plant and laboratory which should be laid in resting stone ware pipes or plastic pipes.

.41 These drainage requirements indicate the stratification of the drainage exercise in a sugar factory and also hints that a layout which does not consider drainage at its early stage can end up in chaos.

.42 In conclusion, planning for services in a sugar factory (and in many cases other factories) one must bear in mind that constant maintenance and alteration to main service lines is almost inevitable and if these service lines are hurried haphazardly in roadways, the frequent excavation of mains can be a recurring nuisance and expense.

.43 For instance roads which have been dug and reinstated always subside to a level below that of the surrounding surface forming a depression on which water collects thus making an untidy and dirty

100 Factory layout contd.

factory and often causing accidents especially at night.

.44 So in case service pipes have to cross a road or working area these are preferably run in ducts with adequate human accesses for maintainance.

.45 An alternative would be to carry them on walls.

.46 But pipes carried on walls are normally unsightly and an attempt is to be made throughout the design to plan for all pipe work.

THE FACTORY BUILDINGS

CHAPTER SEVEN

FACTORY BUILDINGS

0.00

1.00

2.00

3.00

4.00

5.00

6.00

7.00

8.00

In Brief

The manufacturing spaces

Storage spaces

Laboratory spaces

Service spaces

Maintenance spaces

Supervision & Administration

Welfare spaces

In conclusion.

3102 (General objectives) _____

.01 Four walls and a roof over a given floor area may at one time have been satisfactory for a factory.

.02 Infact some industries function in almost any building containing the usual number of walls, utility lines, roofs and floors.

.03 A few get by without any building at all.

.04 But others require industrial structures designed expressly to house their specific functions.

.05 Today, (especially with the more specialized forms of industry) factory buildings require to be designed in close inteoration with the manufacturing process.

.06 Thus the building being basically the shell that houses the producing man, materials, machinery and supporting activities, it must be an integral part of the plant layout.

.07 Therefore to start from scratch to design a factory building around a plant layout means that

the factory buildings contd.



the building must meet the requirements of the plant layout.

.08 But it should be understood that plant layout details cannot be worked out until the building is completely designed.

.09 And as such since plant layout is determined by the manufacturing process one can more or less establish a process plan or section to guide his plant layout & hence building design.

Examples



One storage

One process

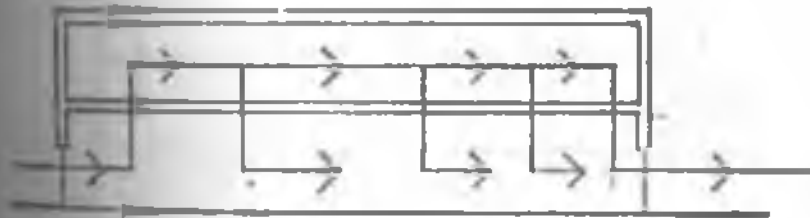

Two storage

Multi-process

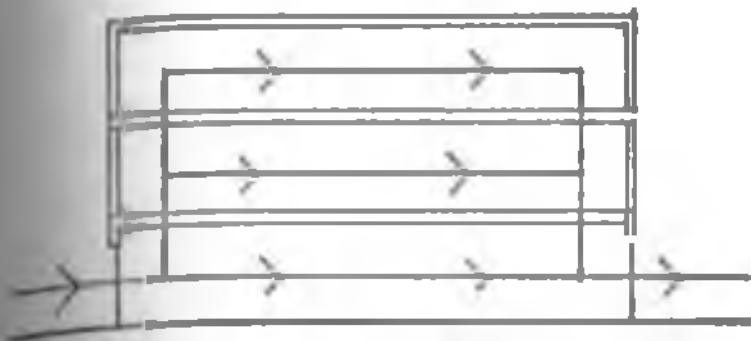

Multi-storey

Single process

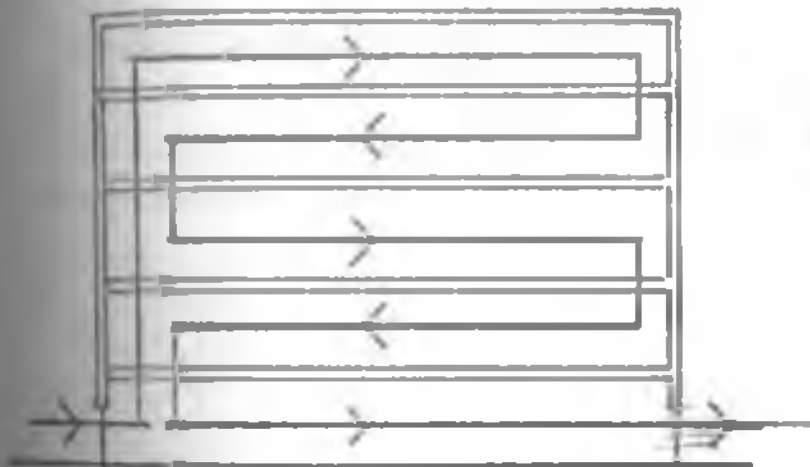

Multi-storey

Continuous process

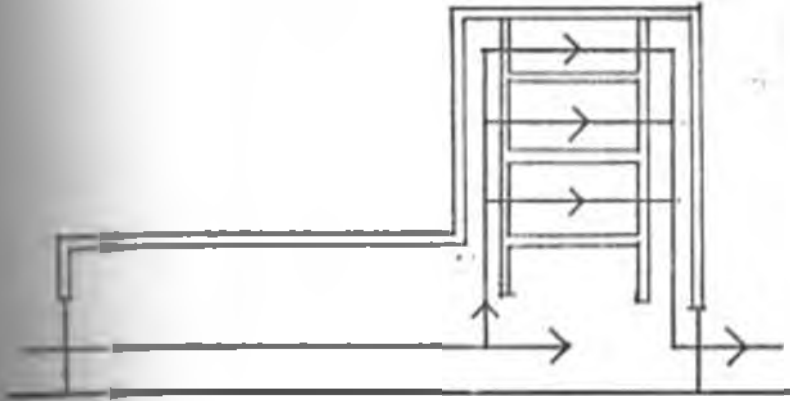

One Storey

With multi-storied storage

One process

factory buildings contd. _____

.10 Having indicated how a manufacturing process can influence section or shape of a building it is now time to move further and see how a sugar factory takes shape.

.11 This I have done by considering each of the function/activity spaces listed in an earlier page.

.12 These spaces include:-

- 1.00 The manufacturing spaces
- 2.00 The storage spaces
- 3.00 Laboratory spaces
- 4.00 Service spaces
- 5.00 Maintenance spaces
- 6.00 Supervision & Administration
- 7.00 Welfare spaces.

2.00 The Manufacturing spaces. _____



.01 In chapter three I outlined the process cane goes through from the time it is harvested until the time it leaves the factory as raw sugar in bags.

.02 Here I have translated that description into a scaled diagram.

.03 The diagram is in the form of the representative machinery and equipment used in the manufacture of sugar.

.04 Each manufacturing stage or station (indicated by a written description) is located in section relative to a base line with due consideration being given to:-

: Weight and vibration of equipment

: Limitations to the use of pumping, gravity or conveyor belt for the movement of the material in process.

.05 Thus from the diagram it can be seen that the

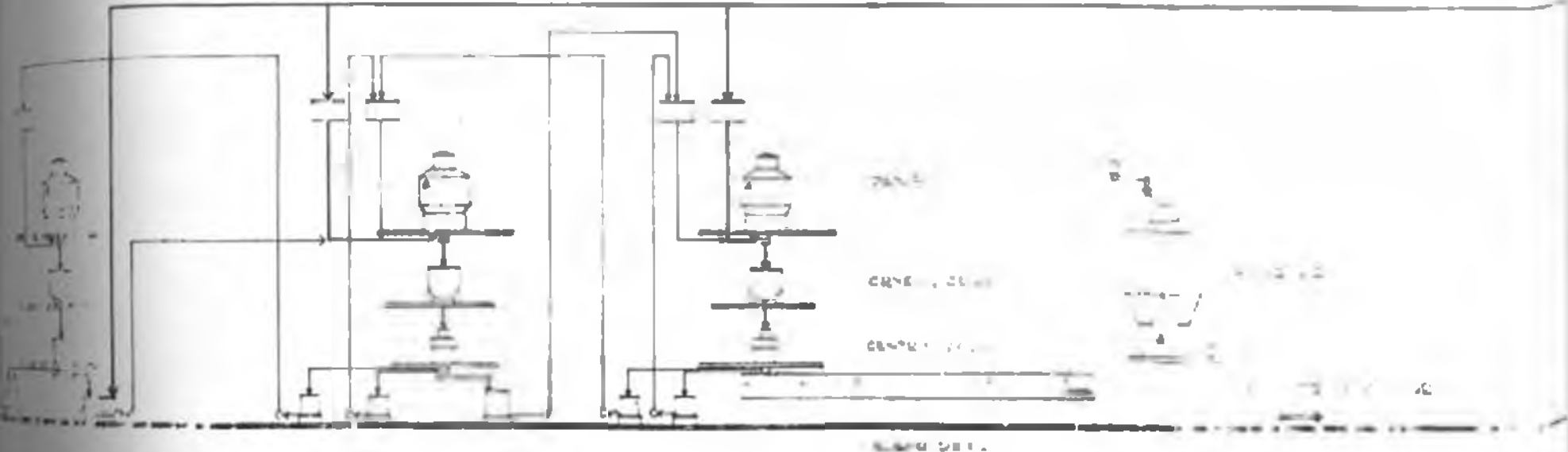
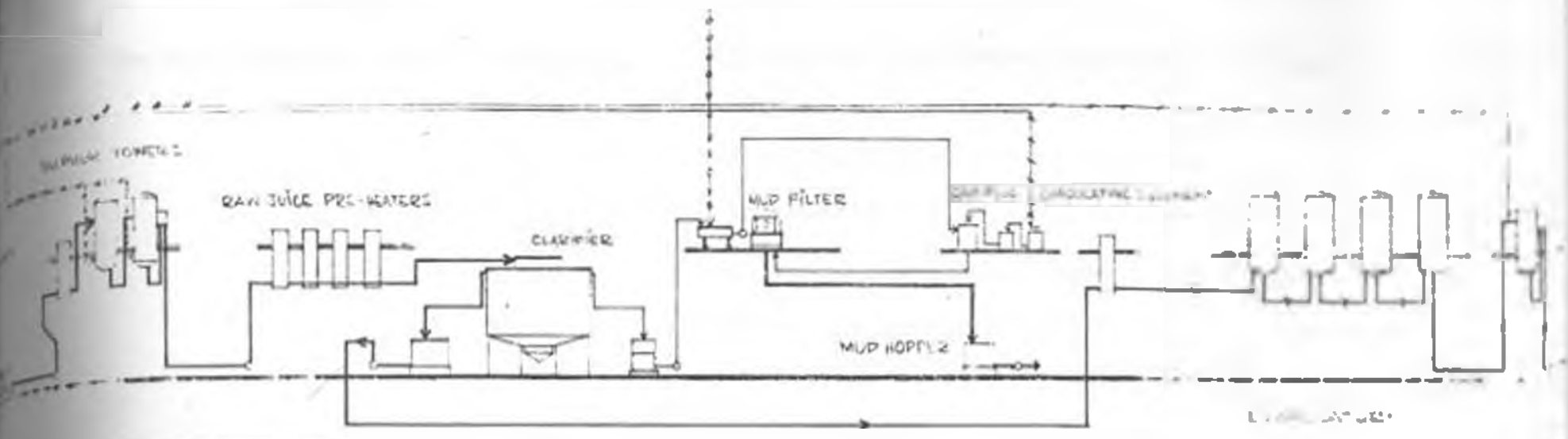

INSTALLATION / PROCESS FLOW DIAGRAM
 SUGAR MANUFACTURING STATION

SCALE 1:500

KEY

	WATER
	RAW JUICE
	MUD
	STEAM
	WASTE

4,792 The manufacturing spaces contd.

milling station (where incoming raw cane is crushed) is placed on the ground floor because it requires a strong foundation due to its very heavy machinery which also cause tremendous vibrations.

.06 Necessity to use gravity for movement of material in process has dictated the location of the centrifugal station below both the crystallizers and vacuum pans.

.07 Gravity is used in the above station because at this point the cane juice has been evaporated to a very thick syrup which is very difficult to pump.

The manufacturing spaces contd. —

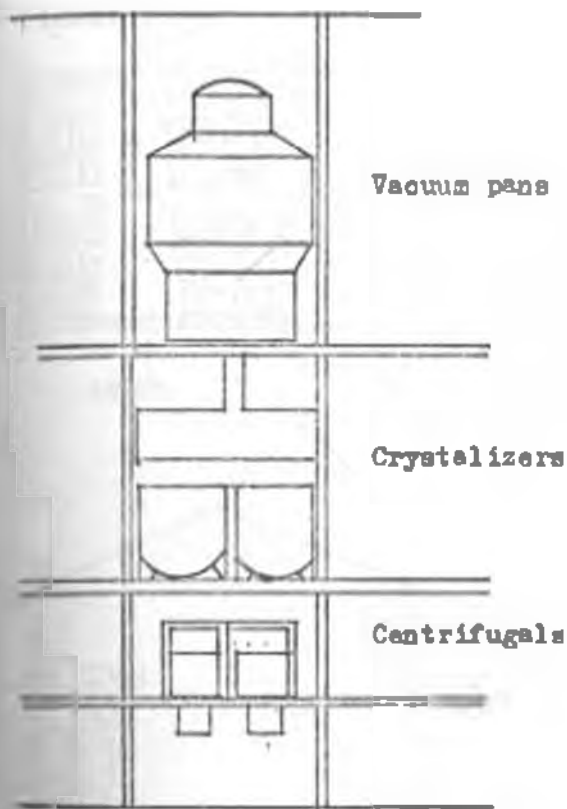

.08 Similarly the location of supporting stations is shown in the diagram.

.09 This diagram does not however include the total numbers of all the machinery and equipment used in the manufacturing process.

.10 The total numbers of each plus the space they occupy are indicated in the building brief appearing later and consequently in the design drawings.

.11 The sizes of the different machinery and equipment are then used to establish a design module when considering the structural grid and heights of ceiling heights and staff operational spaces.

2.00 Storage spaces.

Loading bay

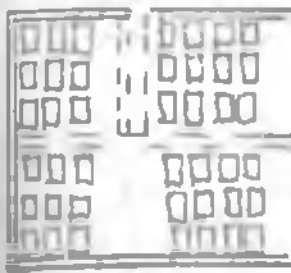

Light



.01 Processed raw sugar is stored at the factory site before it is taken away to the distribution centres.

.02 The store should be able to accommodate more than one week's total stock of manufactured sugar.

.03 Since the sugar is contained in bags the design of the store should take into consideration the size of a sugar bag and use it as a module.

.04 An important constructional detail to observe in the design of a sugar factory is that it is very important that sugar be kept dry and therefore the total floor of the store should have a damp-proof membrane to keep moisture off.

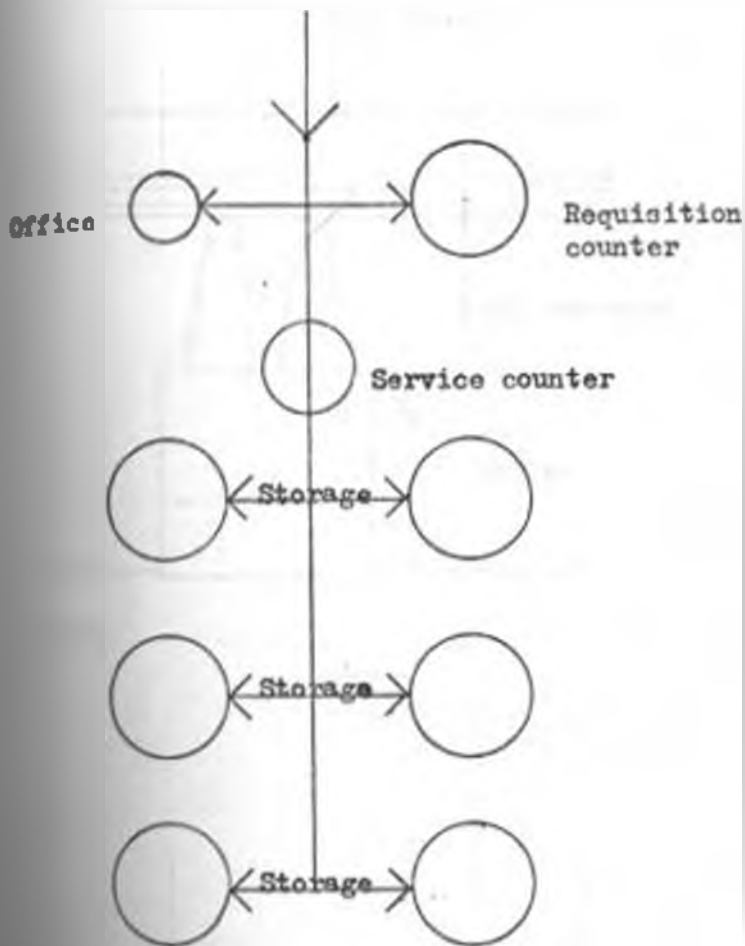

.05 Another important storage area is the general stores where all materials used in the daily supporting of the factory activities are stored.

.06 One needs storage space for the following items:-

- : For factory spare parts
- : Processing chemicals
- : Office equipment
- : Staff uniforms
- : Sanitary materials
- : Building repair materials
- : Field machinery spare parts.

.08 Although some of items included in the above descriptions (e.g. any heavy equipment) are actually stored in their place of use none the less a factory requires a central store where all requirements are made and records kept.

4.00 Service spaces. _____

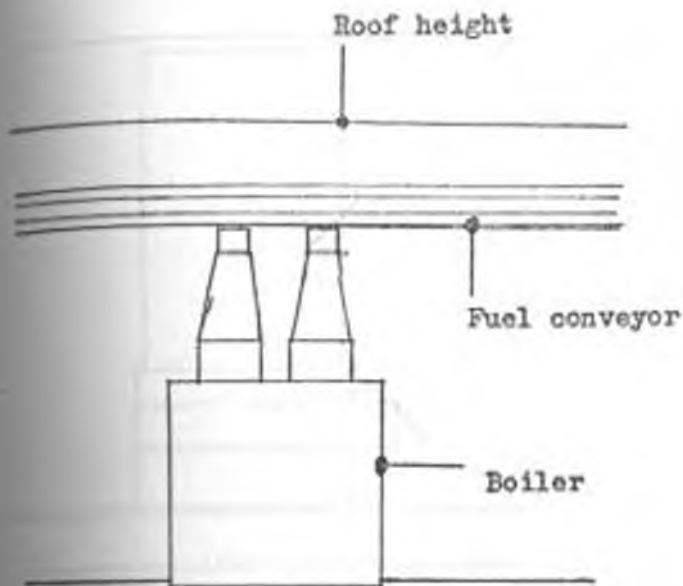

SECTION

.01 The three major service area stations are the power house, the boiler house and the river water treatment pits.

.02 The design or space allocation of the boiler house is greatly dictated by the number of boilers used and the methods of loading fuel.

.03 As I mentioned earlier the fuel used in the boilers is the fibrous cane waste from the mill house.

.04 This fuel is conveyed from the mill house by conveyor belt. Hence the design of the boiler house should allow enough room for the movement of this conveyor belt above the boilers.

6.00 Service spaces contd. _____

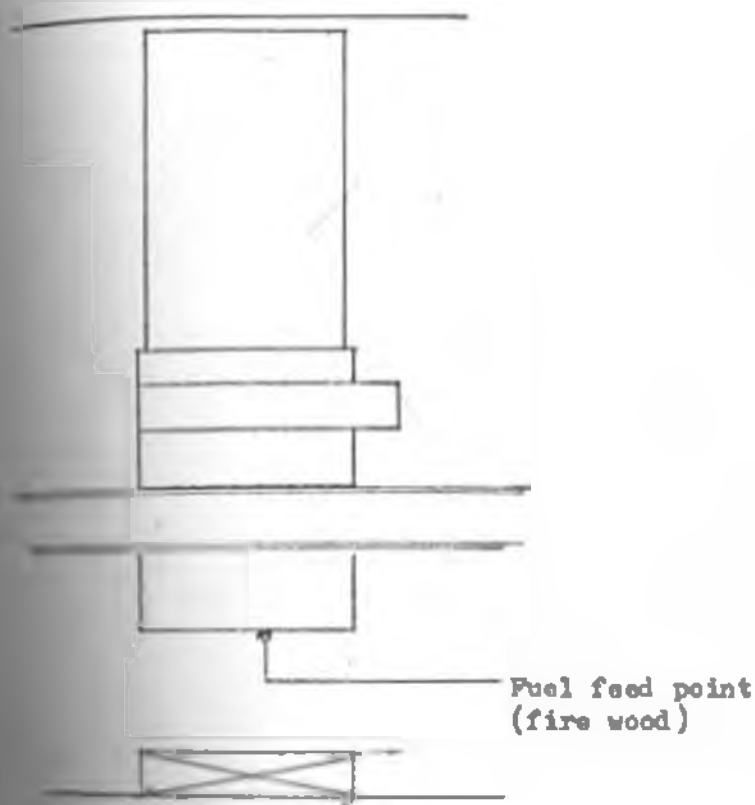

.05 This waste fibre fuel is normally very wet and cannot start burning on its own.

.06 Therefore firewood is used for the first one hour or so to start the boilers really boiling after which the heat attained by the fire is high enough to burn the bagasse.

.07 The boiler room should therefore have space for wood storage and also enough space for feeding of the firewood to the boilers as well as for removing the burnt ashes.

1.00 Service spaces contd. _____

.08 The power house embraces both a transformer station and a diesel generating plant to safeguard any emergency power failure.

.09 The shape and size of this station is by and large dictated by the size and layout of equipment.

.10 But a special feature in the power house is the inclusion of crane facilities for the movement of the heavy plant used for power generation.

4.00 Service spaces contd. _____

.11 As concerns the river water treatment ponds this greatly depends on how dirty the water is.

.12 Very dirty water will require large areas to enable it to move from pit to pit every time being treated to precipitate any suspensions it has.

.13 However, cleaner water will require fairly small area for settlement.

5.00 Maintenance spaces _____

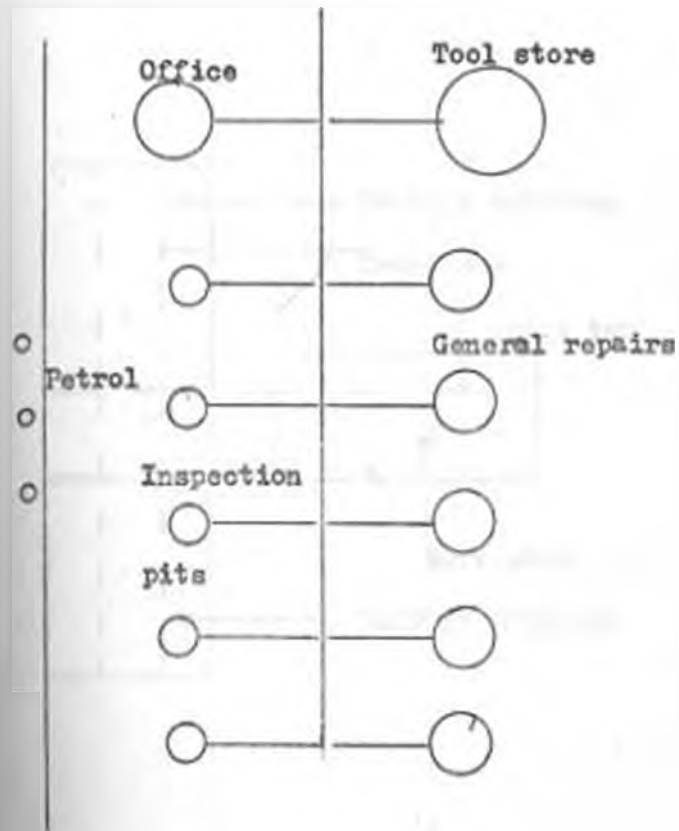

.01 Maintenance of factory plant and equipment, maintenance of factory buildings and that of field vehicles and other vehicles used for factory purposes require provision of specialized and suitable spaces for their various activities.

.02 For the maintenance of factory equipment and machinery one needs to have a workshop located near the factory so that moving distances to and from are reduced to minimum.

.03 Also since some of the equipment & machinery requiring repair are very heavy the movement of these by cranes should be considered.

e.00 Maintenance spaces contd. _____

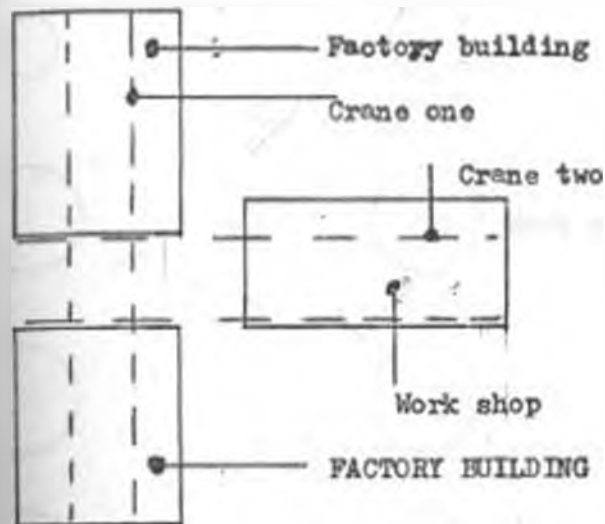

.04 It is possible to design so that a crane can transport broken down equipment right from the factory building to the workshop.

.05 Alternatively this process can be done in two operations i.e. either by one crane handing over to another crane or by one crane handing over to a conveyor belt.

.06 Such a design would save the factory the many hours some existing factories spend in manually transporting heavy equipment.

.07 Accidents could also be reduced through less handling.

00 Maintenance spaces contd. _____

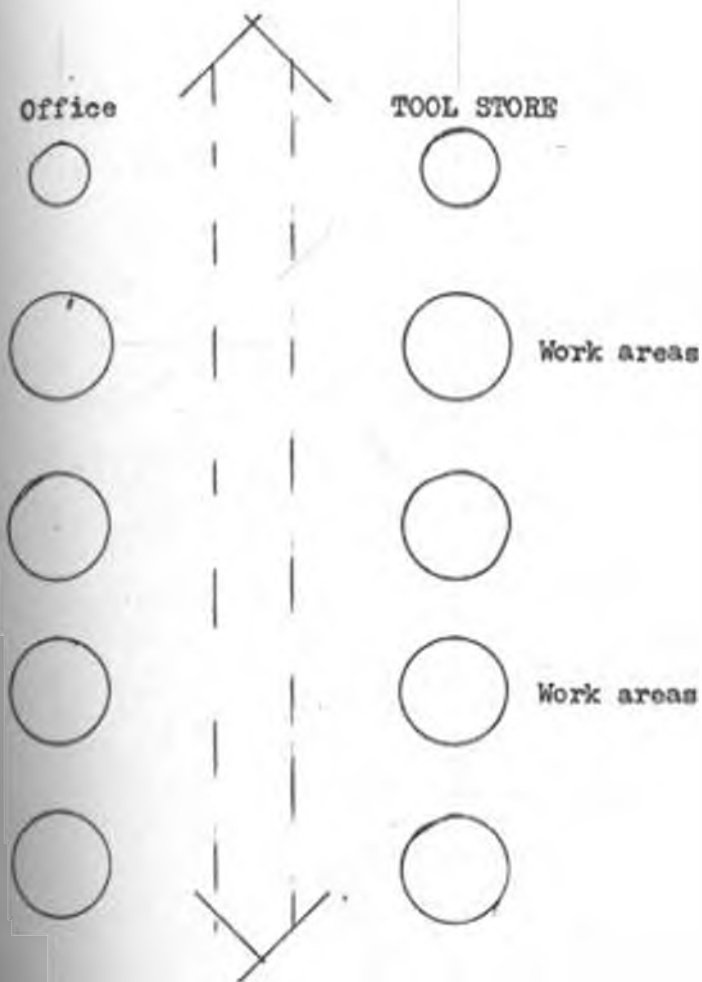

.08 The actual factory workshop should be designed so that detailed work requiring higher levels of lighting are located near windows while other general works can be deeper inside the building.

.09 Space should also be allocated for storage tools and also office space for workshop engineer and his assistant be located in such a way to enable efficient control of the workshop proceedings.

.10 Most of the factors influencing the design of the factory workshop applies to both the field workshop as well as the building workshop.

.11 Only that you do not require the use of cranes in these two cases.

.12 But special features in the field workshop include parking area for the cane transportation vehicles when not in use or when awaiting repair.

.13 Other important inclusions are a petrol and diesel filling station and inspection pits at the vehicles repair garage.

6.00 Supervision and Administration
spaces. _____

.01 Supervision of manufacturing operations and general administration of the firms business have been considered separately in relation to their location.

.02 Supervisors of manufacturing operation should be located near the places they supervise.

.03 They should also be located in such a way that they have visual control of their area.

.04 Thus location say on a mezzanine floor would be a great advantage.

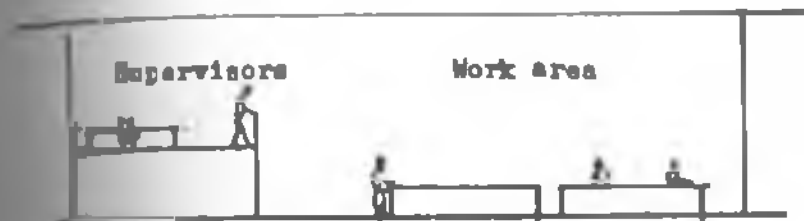

1.00

Supervision and Administrative

spaces contd. _____

.05 It is therefore clear that such supervisory spaces should be located right inside the factory building.

.06 The amount of spaces required is governed by the number of offices but the space standards to be used are based on design guide space standards and also from observations from case studies (see brief

.07 On the other hand the spaces for the general administration of the firms business do not have to be in the manufacturing building.

.08 Such office space should be placed in a separate wing or even a separate building as the officers working there have got remote relations with the actual manufacturing.

6.00 Supervision and administrative spaces contd. _____

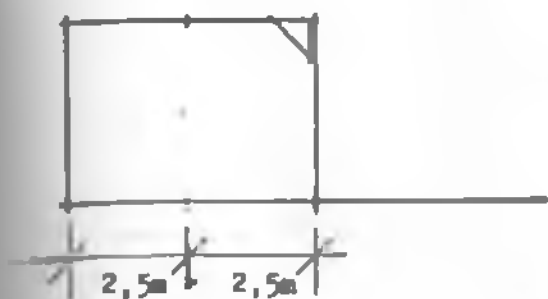

Junior officer.

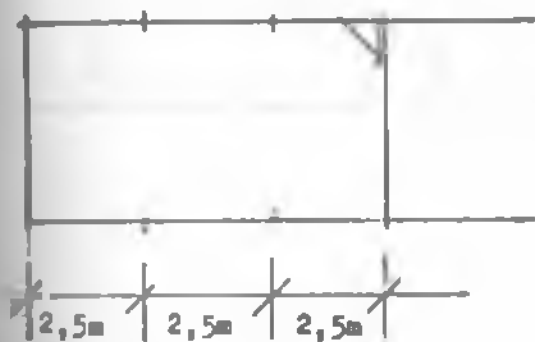

Senior officer.

.09 Therefore in a factory location like that of a sugar factory in the plantation it is possible to create some beautiful office building with good surrounding.

.10 Such a building is to be designed to accommodate the firms management bosses, personnel department, accounting department, purchasing department, agricultural department, a seminar or conference room and other supporting spaces e.g. stores, secretary rooms and even toilets.

.11 As such the design should have a module that can be multiplied to give space dimensions required by the different user functions.

7.00 Welfare spaces. _____

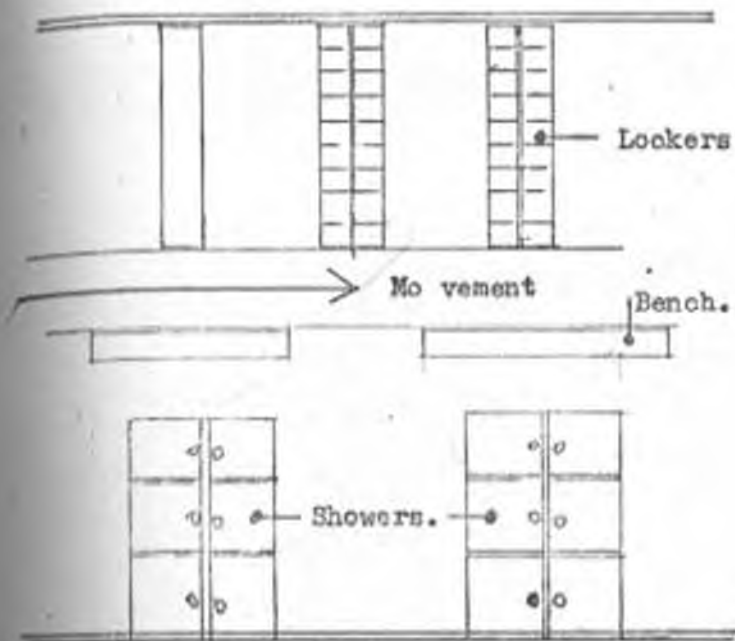

.01 Workers changing rooms, showers, toilets, and canteen should be adjusted to their place of work.

.02 Locker facilities should be provided for all the workers with each worker allocated one locker though with bigger lockers and good worker relationships two workers can share a locker.

.03 Lockers should be ventilated to enable wet clothing to dry - the locker door could be of wire mesh.

.04 Sitting surfaces should be allowed at the changing area - preferably located between the locker and the showers.

7.00 Welfare spaces contd. _____

- .05 In the brief following in the next chapter I have indicated the number of lockers, w.c.'s showers etc to be provided as governed by the number of users per shift.
- .06 In a factory like the one I am designing, workers normally go on a shift of eight hours without a major meal break.
- .07 But the factory normally provides tea at certain breaks.
- .08 The canteen for this purpose is best located just next to the factory.
- .09 Space should be adequate for sitting the total number of workers in one shift.
- .10 It is also necessary to provide dispensary and first aid facilities to cater for general illness and accidents.
- .11 Such a medical facility should have about two bed places for critical cases since the factory is

00

Welfare spaces contd. _____

fairly remote from the main regional centre.

Conclusion _____

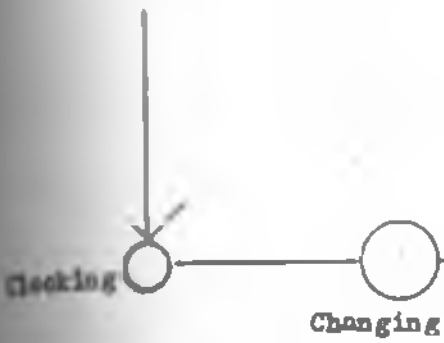

.01 This chapter has outlined in general the kind of activities to be catered for in the factory estate.

.02 The requirements of each of the seven activity spaces have been discussed at a fairly micro level to enable the author to give a visual thought as to what the spaces required by the activities will look like.

.03 For instance a worker arrives at the factory site, clocks in, goes through the changing rooms and then to his work place - at each station going through some arranged spaces according to activity requirements.

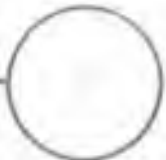

Working
area.

8.00

Conclusion contd.

.04 The next chapter now contains an inventory of the actual space requirements of the various spaces

.05 These spaces have been derived from observations made from case studies made during visits to existing factories and also from readings of materials on factory building requirements.

CHAPTER EIGHT

THE BUILDING BRIEF

brief. _____

.01 Here are found space requirements of the functions to be catered for in the design project.

.02 The first part is in the form of measured scaled drawings of the different equipment and machinery (major) that are to be accommodated in the factory.

.03 These drawings also show the spaces required around these giant equipments & machinery plus the numbers of each type of equipment or machinery that are to be designed for.

.04 Dimensions are in metres.

.05 The second part is an inventory in tabular form of all the other spaces that are required for other functions in the sugar factory.

.06 The abbreviations h, l, w, a, stand for height, length, width and area.

.07 Attention is drawn to the point that the character has four sections:

Brief contd. _____

-
- : That dealing with factory process spaces
 - : That dealing with factory administration
 - : That dealing with welfare facilities
 - : That dealing with general business administration.

.08 At the end there are other tables showing space requirements as obtained from case studies carried out in Chemilil and Mumias sugar factories in September 1972.

.09 It is from the tour experience to the above mentioned factories in Western Kenya and the case studies carried there that forms the basis of the brief so formulated.

.10 Actual construction drawings of the existing factories cannot be included in this thesis because these factories were designed by overseas 'experts' who went away with their drawings after erecting the factories.

brief contd. _____



[Faint, illegible text or markings, possibly a header or title area]

[Faint, illegible text or markings, possibly a list or table header]

[Faint, illegible text or markings]

.11 For quantitative orientation as far as this factory is concerned I should mention that this brief is designed for (or based on) a factory with an average cane crushing capacity of 100 metric tons of cane per hour.

.12 The determining factor is the crushing capacity of the mill house.

.13 Six mills can crush an average of 100 metric tons of cane per hour though allowance for a seventh mill is made for in the design in case it is required to raise juice extraction to around 80% dryness (free bagasse moisture).

.14 A quantitative flow chart included in this thesis shows the quantities of materials and waste handled by such a sugar factory.

.15 All the quantities are in metric tons.

.16 As seen in this chart (next page) 100 metric tons of raw cane will yield 10 metric tons of raw sugar.

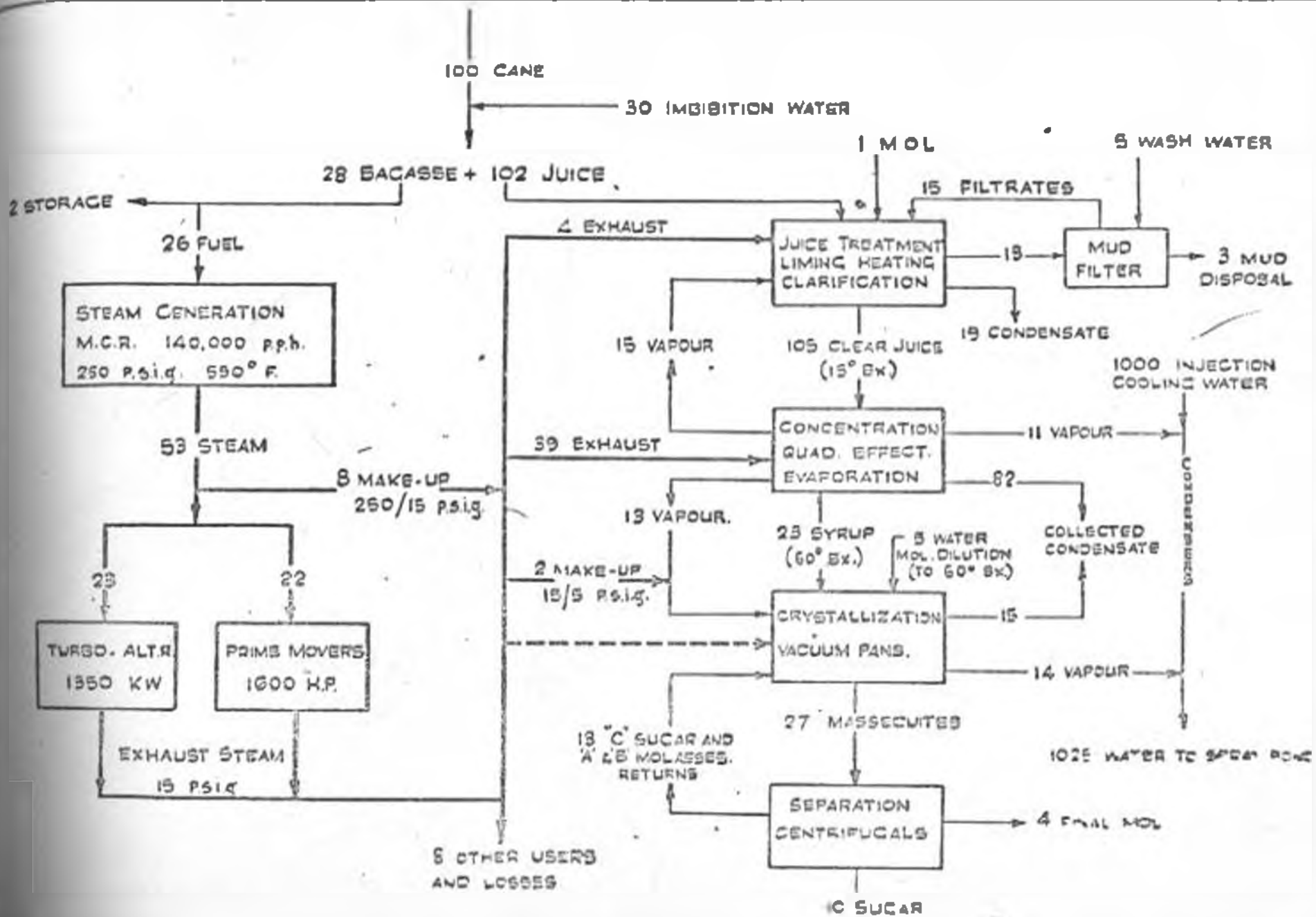

228f contd. _____

.17 Therefore the design of any department a. s.
the sugar store is based on a volume to store
sugar produced at such a rate for a period of say
two weeks.

MEASURED EQUIPMENT AND MACHINERY.



Boiler House

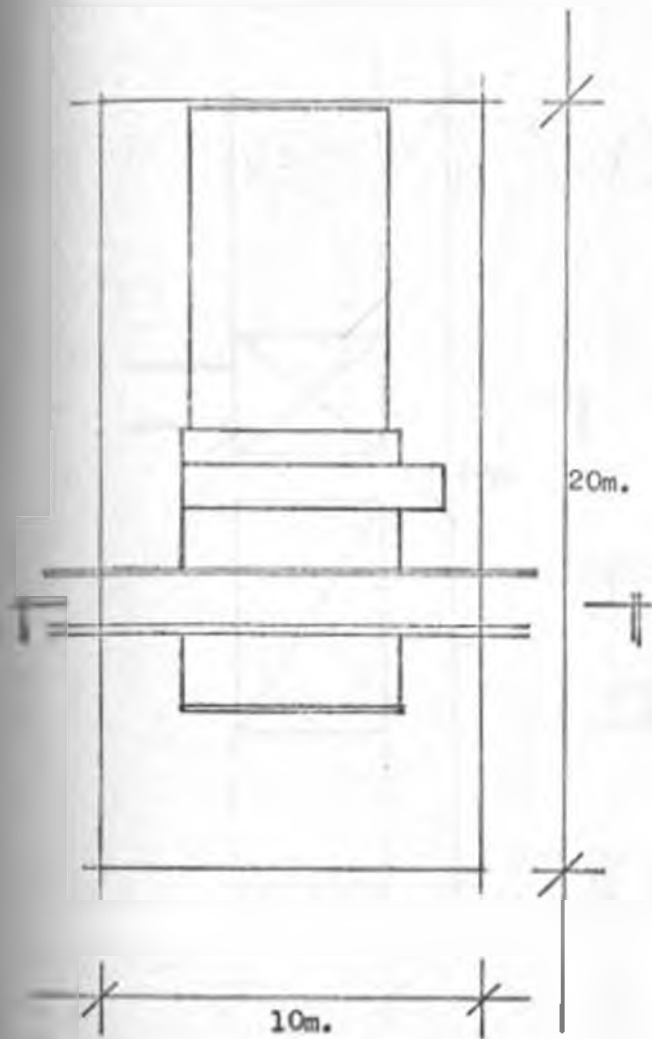

Plan

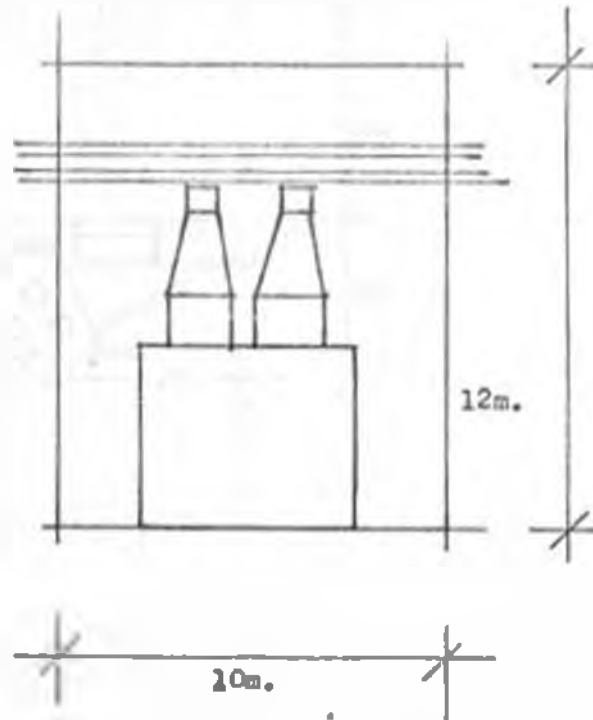

Section

Area per boiler	200m ²
No. of boilers	4
Total area	800 m ²

all House

T



Plan

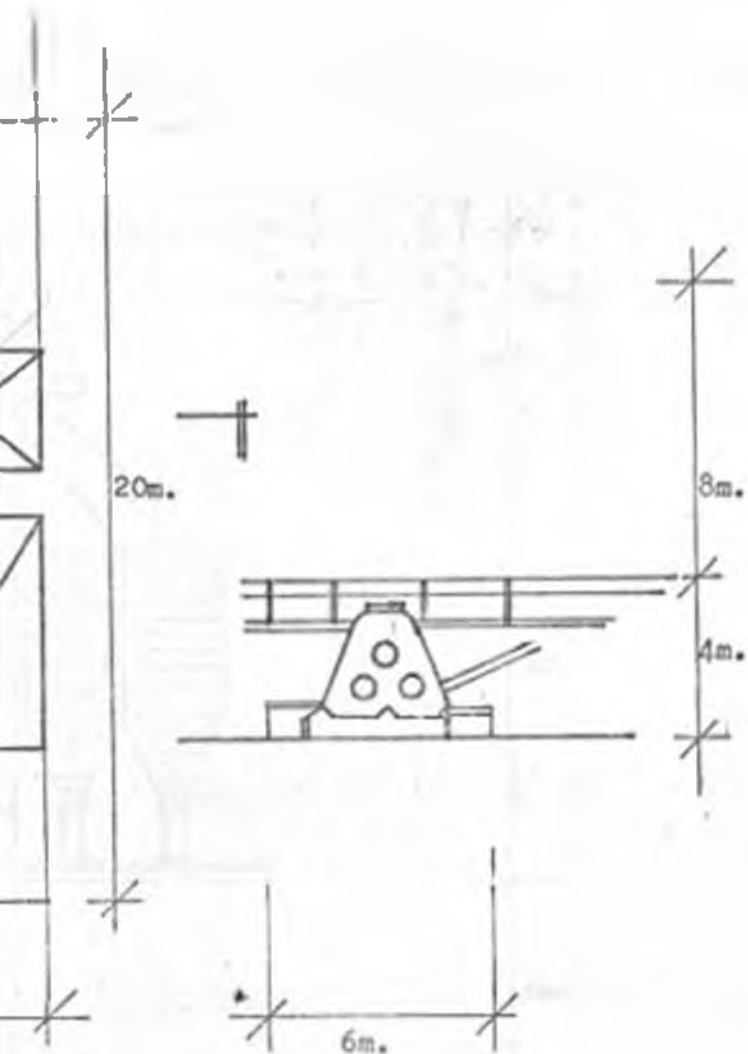

Area per tandem	100 m ²
No. of tandems	7
Total Area	700 m ²
Control Area	300 m ²
Operating Area	800 m ²
Total Area	1800 m ²

Section

Sugar Bins

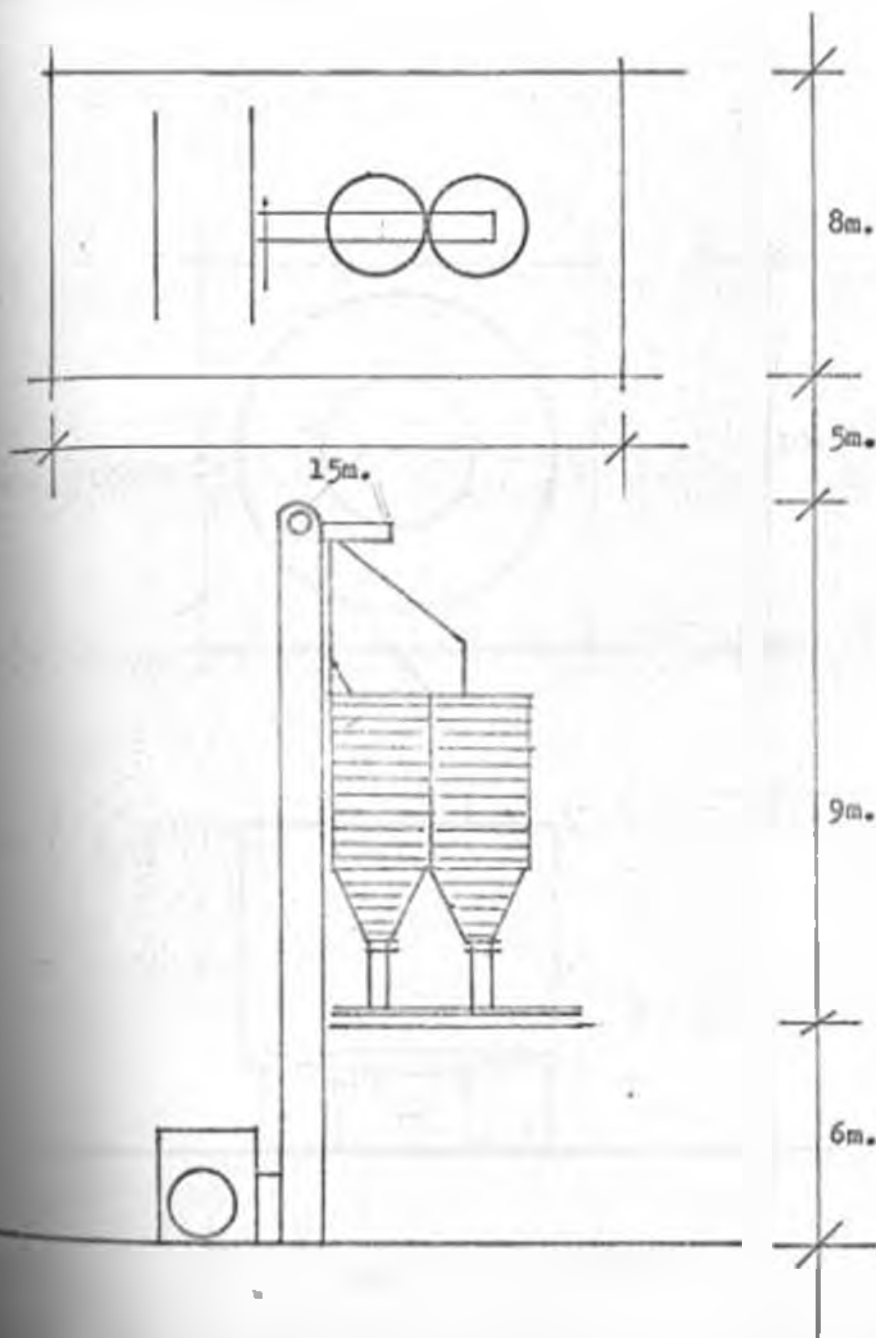

Plan

Area per bin	120 m ²
No. of bins	1
Total area	120 m ²

Elevation

Clarifiers

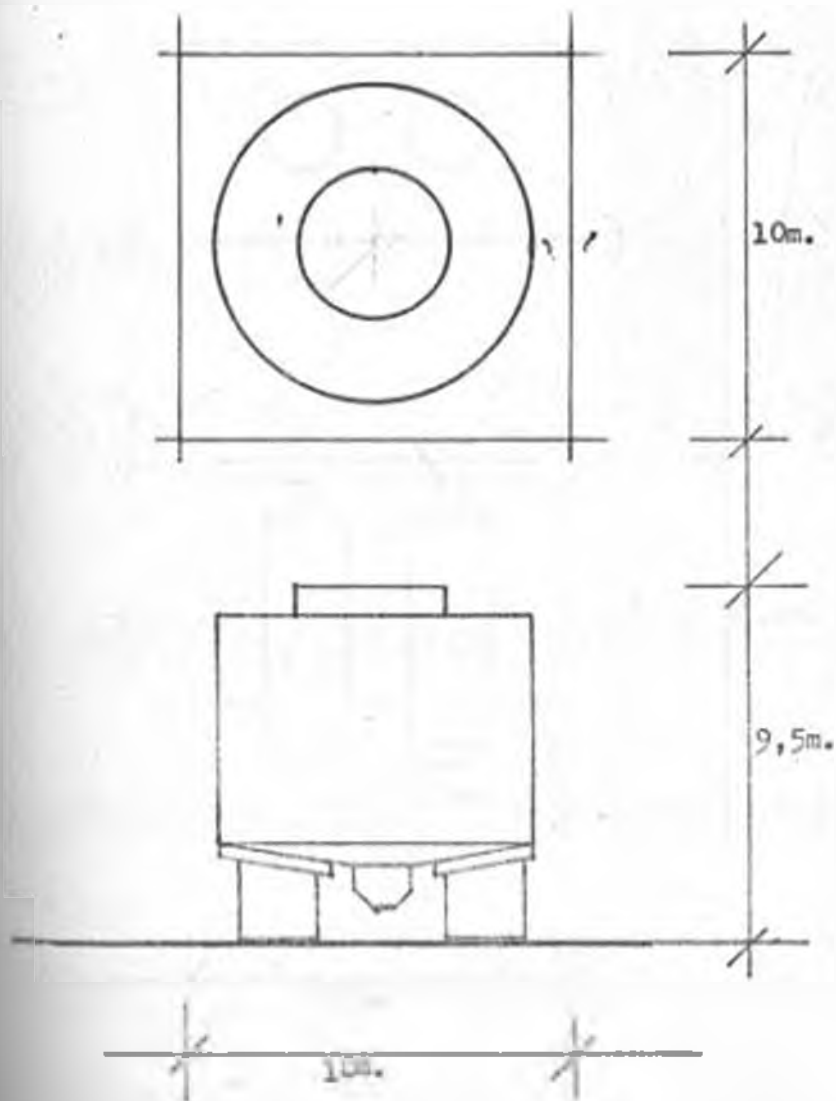

Plan

Area per clarifier	100 m ²
No. of clarifiers	2
Total area	200 m ²

Elevation

Pre-heaters

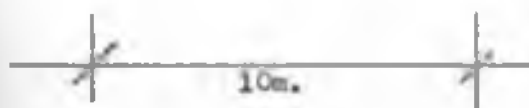
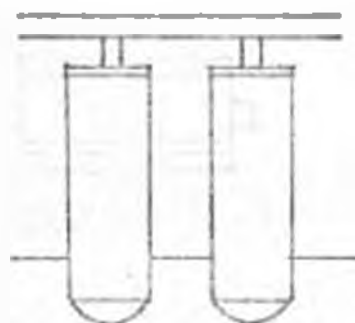
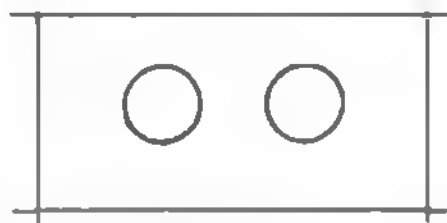

Area per pair	50 m ²
No. of pairs	2
Total area	100 m ²

124 filters

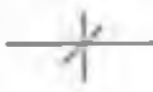



Plan

Area per filter	35 m ²
No. of filters	2
Total area	70 m ²
Mud hopping	25 m ²
Gearing Equipment	25 m ²
Total area	120 m ²

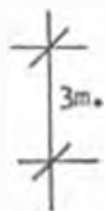

Elevation



Evaporators

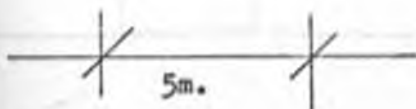
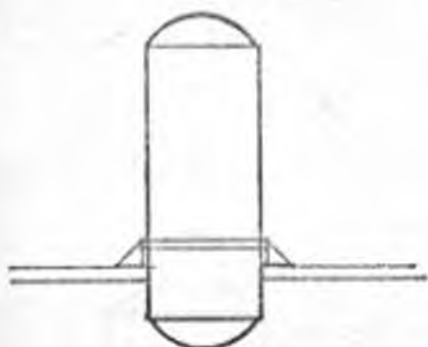
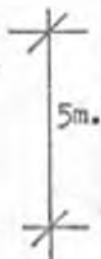
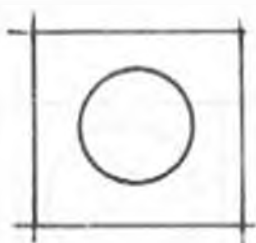

Plan

Area per evaporator	25 m ²
No. of evaporators	6
Total area	150 m ²

Elevation

Pano

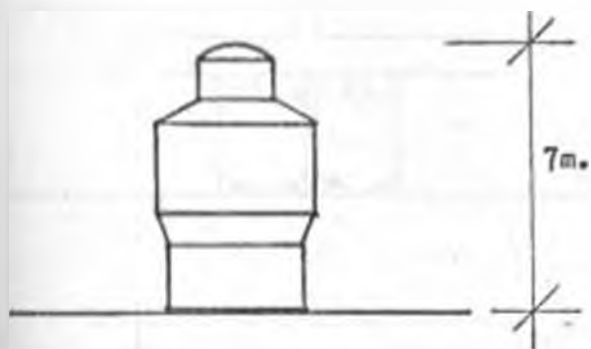
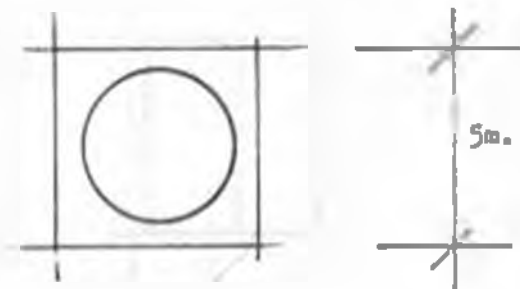

Plan

Area per pan	25 m ²
No. of pans	8
Total area	200 m ²
Auxilliary space	200 m ²
Total area	400 m ²

Elevation

Crystallizers

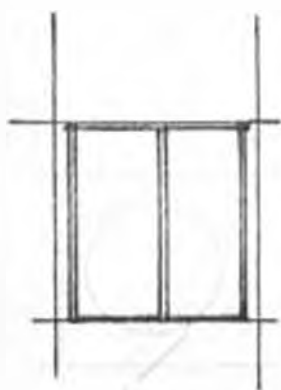

Plan

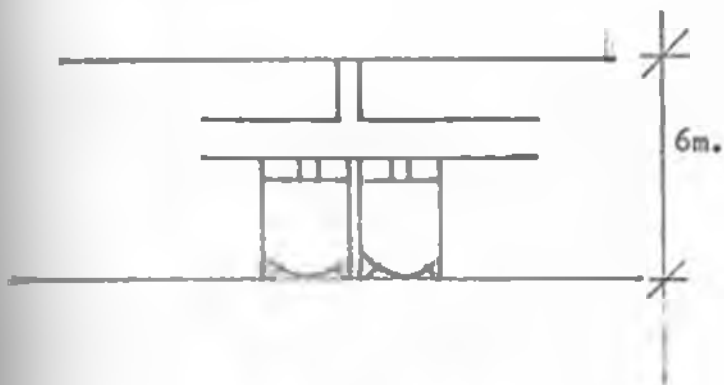

6m.

Section



Area per crystallizer	25 m ²
No. of crystallizers	8
Total area	200 m ²
Cooling control	200 m ²
Total area	400 m ²

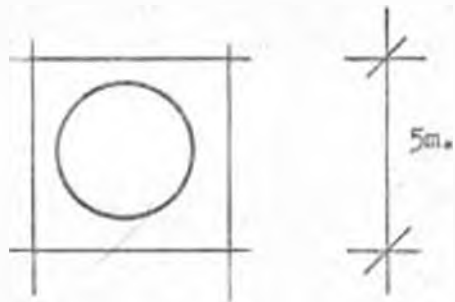

Plan

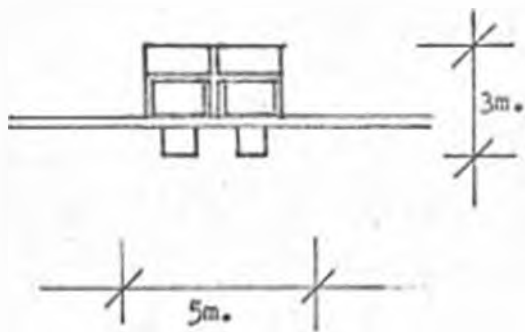

Section

Area per centrifugal	25 m ²
No. of centrifugals	8
Total area	200 m ²

- 1.00 Security
- 2.00 Weigh house
- 3.00 Weigh bridge (x2)
- 4.00 Cane storage
- 5.00 Feed tables (x2)
- 6.00 Kniving
- 7.00 Bagasse house
- 8.00 Molasses tanks
- 9.00 Sugar store
- 10.00 Power house
- 11.00 Lime/sulphur store
- 12.00 Water treatment
- 13.00 Water settlement pits.
- 14.00 River pump house
- 15.00 Field w/shop (15 tractors at a go)
- 16.00 Factory w/shop
- 17.00 Main store
- 18.00 Building w/shop
- 19.00 Rack for serviced vehicles (40 tractors, 100 trailers)
- 20.00 Petrol station
(3 pumps)
- 21.00 Oil store (factory)

b	w	l	a
3	5	10	50
3	5	10	50
-	3	10	60
	50	70	3500
	6	10	60
8	8	10	80
12	20	20	400
10	15	15	225
12	20	90	1800
12	10	15	150
6	5	5	25
3	10	20	200
-	50	80	4000
-	-	-	-
6	20	80	1600
12	20	50	1000
6	20	50	1000
6	20	30	600
70	100	7000	
5	20	100	
5	5	25	

Laboratory

Senior Analyst

Chief Chemist

Chemist/Technologist

No.	h	l	w	a
4	28	20	4,8	96
	28	5	4,8	24
	28	7,5	4,8	360
	28	5	4,8	24

Factory Administration

Engineering Manager

Maintenance Engineer

Electrical Engineer

Technical Office

Secretary & Typist

Production Manager

Production Supervisors

(3 shift chemists)

Shift Supervisors (4 on shift)

Supplies office

No.	B	l	w	A
1	2,8	7,5	4,8	36
1	2,8	5	4,8	24,0
1	2,8	5	4,8	24,0
4	2,8	20	4,8	96,0
1	2,8	5	4,8	24
1	2,8	5	4,8	24,0
3	2,8	7,5	4,8	36
	2,8	5	4,8	24
4	2,8	5	4,8	24
1		5	4,8	24

Personnel & training advisor

Personnel & Training Officer

Secretary

Senior Personnel Officer

Personnel Officer

Welfare Officer

General Manager

Secretary & Typist

Chief Accountant

Assistant Chief Accountant

Acc. general office

Accountant x2

Salary office

Purchasing & Sales Controller

Telephonist/receptionist

Conference Room

Library

No.	h	l	w	a
1	2,8	10	4,4	440
1	2,8	7,5	4,4	33,0
1	2,8	5,0	4,4	22,0
1	2,8	7,5	4,4	33,0
1	2,8	5,0	4,4	22
2	2,8	7,5	4,4	33
1	2,8	5,0	4,4	22
2	2,8	5,0	4,4	22
1	2,8	7,5	4,4	33
1		5,0	4,4	22
		12,0	4,4	55,0
2		7,5	4,4	33
3	2,8	7,5	4,4	33
	2,8	5,0	4,4	22
1	2,8	5,0	4,4	22
	2,8	10	10	100
	2,8	10	10	100

1. Agricultural Manager
2. Deputy Manager
3. Nuclear Estate Manager
4. Assistant Nuclear Estate Manager
5. Outgrowers Manager
6. Harvesting Manager
7. Field w/shop Manager
8. W/shop Engineer
9. Agricultural Engineer
10. Assistant Agricultural Engineer
11. W/shop Superintendent
12. Agronomist
13. Farm Records
14. Secretaries/Typists x2
Secretaries/Typists

No.	h	l	w	a
1	2,8	1,0	4,4	44,0
1		7,5	4,4	33
1		7,5	4,4	33
1		5	4,4	22
		5	4,4	22
2		7,5	4,4	33
1		5,0	4,4	22
1		5,0	4,4	22
1		5,0	4,4	22
2		7,5	4,4	33
2		5,0	4,4	22
3		10	4,4	44
		7,5	4,4	33
2		5,0	4,4	22
2		5,0	4,4	22

Welfare facilities

Canteen
Dispensary - 2 beds
Union Hq.

h	l	w
3	35	10
3	30	10
3	30	10

Showers 22 - 1 per 5 workers (150)

Lockers 150 - 1/2 workers

Wash basins 50 - 1/2 workers

w/c's 10 1 for 10

Urinal 20 people queuing

Cloaking

Men changing 2 showers lwc.

n	l	m
3	25	4,4
3	20	4,4
3	15	2
3	15	3
	10	3
3	5	44
3	5	4,4

CASE STUDY SPACE STANDARDS.



1. Security
2. Weigh house
3. Weigh bridge (x2)
4. Cane storage
5. Feed tables (x2)
6. Kniving
7. Mill house
8. Boiler house
9. Bagasse house
10. Clarification/weighing/lining
11. Evaporating & heating
12. Pans
13. Crystallizers
14. Centrifugals & Sugar drier
15. Molasses tanks (x2)
16. Sugar bin/bagging/bag storage
17. Sugar storage
18. Power house (electric)
19. Lime & Sulphur store
20. Water treatment
21. Settling pits (water)
22. River pump house
23. Field W/shop (trucks
vehicles)

MUMIAS

CHERNILIL

h	w	l	a	h	w	l	a
2,8	5	7	35	3	7	10	70
2,8	5	6	30	3	3,5	9	31,5
0	3	8	24	0	3	19	57
0	25	40	1000	0	15	40	600
0	6	9	54	0	6	10	60
0	10	10	100	7	8	9	72
12,2	22	50	1100	13,5	23,0	45,0	1035
15,2	20	22	440	13,5	23,0	40,0	920
13	21	31	651	13,5	23	25	575
-	10	29	290	11,5	11	30	330
-	22	28	616	10	11	22	242
10	5,5	10		9,5	16	45	720
6	5,5	10		5	16	45	720
6	10	35	350	6,5	10	22,5	225
5		10				13	
	10	22	220	14	5,5	15	90
12	22	41	902	12	25	85	2125
12	10	29	290	10,5	16,5	22	374
-	9	12	108	8,0	10,0	15,0	150
-	12	12	144		6	29	174
-	8	20	160		46	69	3220
5	22	64	1408	7	20	40	800

24. **Factory workshop**
25. **Main store**
26. **Building workshop**
27. **Back for serviced vehicles**
28. **Petrol station**
29. **Oil store**

M U N I A S

C H E M I L I L

h	w	l	a	h	w	l	a
10	22	32	704	11	20	50	1000
5	22	32	704	6,5	10	22	220
-	10	22	220	-	10	16	160
-	45	95	4275	-	65	65	4225
					4	13	52

diam 6

diam 6

1. Personnel & Training Advisor
2. Personnel & Training Advisor
3. Secretary
4. Senior Personnel Officer
5. Personnel Officer
6. Welfare Officer
7. General Manager
8. Secretary
9. Chief Accountant
10. Assistant Chief Accountant
11. Acc. General Office
12. Accountants
13. Salary Office
14. Purchasing & Sales Controller
15. Telephonist reception
16. Conference Room
17. Pool - xerox
18. Store -
19. Library

CHEMILIL

No.	h	w	l	a
1		5	6	30
1	2,6	5	6	30
1		5	3	15
1		5	6	30
1		5	6	30
1		4	6	24
1		5	6	30
1		4	3	12
1		4	6	24
1		4	6	24
5		5	12	60
2		5	3	15
3		4	9	36
1		5	6	30
2		4	6	24
2		10	9	90
2		4	5	20
		4	3	12
		10	6	60

Lab. - Chemist Technologist

Senior Analyst

Chief Chemist

Engineering Manager

Secretary

Production Supervisors (4 shift chem.)

Production Manager

Senior Supervisors (4 on shift)

Supplies Officer

b	w	l	a
3,5	6,5	16,5	107,75
	6,5		
	6,5	5,5	37,75

3,5	6,5	5,5
-----	-----	-----

3	11
3	11
3	11
3	11
3	11

Washing room 48 basins 10 showers

Changing room 90 lockers

Wo's. 8

Public toilets 4 + urinal

Urinal (15 queing)

C H E M I L I L

h	l	w	a
3,5	11	9,5	104,5
3,5	22	9,5	220
3,5	11	3	33
	6	5	30
	8	3	24

Canteen
Dispensary

MUMIAS				CHEMILIL			
h	l	w	a	h	l	w	a
	26	6,5	182		27,5	9,5	247,5
	30	8	240		11	9,5	104,5

CHAPTER NINE

HOUSING

.01 As indicated earlier the location of the ~~near~~ factory relative to the large cane plantations around it completely isolates the factory estates from any possible rural habitation.

.02 As such if workers are to commute to the factory daily from their homes the factory management will have to arrange for transportation to and from the work place daily.

.03 This transportation business can be very complicated especially with a factory which has to be operated through 24 hours on a shift basis by people who come from several directions.

.04 The best way out is to house the workers at the factory estate.

.05 Actually this idea of workers of one establishment living together has other advantages.

.06 As they continue to live together they get to know each other more and this improves their work relations resulting in greater efficiency at the 173

Housing contd. _____

work place.

.07 Social facilities and other extracurricular activities also become easy to organise and keep alive.

.08 Now as concerns the actual housing facilities to be provided I do not have to mention the well known fact that today, provision of housing is a very expensive undertaking.

.09 For instance in Kenya the Government, Politicians and trade Unionists have made statements criticizing the poor quality of houses provided to workers by various firms.

.10 Infact it is almost official that the Government cannot accept single bedroom family houses anywhere.

.11 This, they say is what the colonialists used to provide and the Wananohi should get better treatment ten years after independence.

Housing contd. _____

.12 I personally think that this is very correct thinking and although the Government has done some good work in providing houses here and there and laying down a sound housing policy there are still many families living in single bedroom houses. A better pace is otherwise important.

.13 Research institutions like the Housing Research Unit of the University of Nairobi should be made aware of this Government desire so that their researches can be directed to producing these space standards at acceptable costs. Too much theorizing is too expensive and our problems require immediate solving not talking or writing.

.14 I can recall that several discussions were held over the Labor accommodation problem in the now nearing completion sugar factory at Mumias.

.15 The company found it economically impossible to provide the required standards of houses for their workers.

Housing contd. _____

.16 The meeting, attended by Government and the sugar company representatives could not come out with any clear cut recommendation.

.17 But at the time of writing this thesis there are studies being carried out on how to develop the Mumias township.

.18 Since the factory site is near the township such a development could include houses which the workers could occupy.

.19 It is also important to note that a sugar factory estate of the size found in Kenya contains approximately 3000 people.

.20 Such a large number of people will therefore require shopping facilities and other social amenities.

.21 Thus this intention of developing Mumias township could be quite a good example to any future sugar factory developments.

Howain - contd.

.22 It concerns the actual houses those (according to observations made during my tour in September) are categorized into four groups:-

- : Houses for Managers
- : Houses for Senior Staff
- : Houses for Junior Staff
- : Houses for Labourers.

.23 Chemillil Sugar Factory Estate layout gives an indication of the above.

.24 Referring to the list given above the present houses range from mud huts for the labourers to Nuthaina type of bungalow for the Managers (Chemillil Sugar Estate).

.25 The middle class houses in the Chemillil survey are typical to those found in some new estates in the Eastlands.

.26 In Mumias they had only managed to construct the Managerial houses and a few for the middle staff



JUNIOR STAFF HOUSES



Housing contd. _____

None for the labourers - as I pointed out earlier there is still a dead lock on the size of the houses and also who is to provide the money for construction - the Government or the company.

.27 I cannot avoid noting that though the company claims it cannot afford to provide the many houses for its low grade workers their senior staff houses are too extravagant.

.28 Plus the very elaborate members clubs they build for their fifty or so senior staff and only a football pitch for the rest.

.29 Anyway this thesis does not intend to go to the stage of suggesting the kind of housing facilities to be provided as such a stage could form a thesis on its own.

.30 But I have nonetheless tried to point out complications in this housing problem so that the promoters of any future factory should start

Housing contd.

thinking about the housing problem earlier than they start thinking about plant layout.

Bibliography

.01 Ideas and facts expressed in this thesis are from various sources.

.02 A good number are derived from my personal experience resulting from all extensive visit I made to Chemilil and Ibumia sugar factories in September 1972.

.03 Discussions with the staff of the above factories also brought in many new ideas.

.04 Consultations with several officers in the Ministry of Finance & Economic Planning, and the Ministry of Agriculture gave me the basic agricultural planning background - material.

.05 Also useful were readings from a book under the title, "The Manufacture and Refinery of Raw Cane Sugar."

.06 Another commendable book was, "A Handbook of Cane Sugar Technology". by E. Hucot.

.07 Other books e.g. "Practical Plant Layout",

Bibliography contd.

and "Mechanics of Crushing Cane" by Murry G. also provided good reading and technical knowledge.

.08 "Modern Factories" and "Transport and Industrial Buildings 27 01 378" provided examples of various industrial buildings.

.09 "Budgetary Control, Standard Costing and Factory Administration" by Cave RS, "Physical Working Conditions" by McCollough, "Industrial Waste Disposal" by R.D. Ross and "Management of Production" by Radford J.D. were also found useful.